



indesign
Showroom London
WARDROBES

CONDIZIONI GENERALI DI VENDITA / GENERAL SALES CONDITIONS

1) Condizioni generali

Quanto riportato in calce regola i rapporti tra Cubo Design s.r.l. ed il cliente, nominati rispettivamente a VENDITRICE" e "CLIENTE" o congiuntamente le "PARTI". Accordi differenti rispetto le CONDIZIONI GENERALI DI VENDITA non saranno efficaci se non sottoscritti per iscritto da ambedue le PARTI

2) Prezzo

Il prezzo di vendita praticato dei prodotti della VENDITRICE è il prezzo vigente al momento della prevista consegna/ritiro; il CLIENTE è tenuto ad accertarsi di possedere il listino prezzi aggiornato. La conferma d'ordine o altra comunicazione scritta metteranno a conoscenza il cliente di eventuali aumenti di prezzo, detti aumenti sono ad insindacabile giudizio della VENDITRICE, così come i prezzi di eventuali prodotti fuori catalogo.

3) Prodotti fuori catalogo o eventuali prodotti standard modificati

Gli ordinativi di prodotti fuori catalogo dovranno essere sempre accettati dalla VENDITRICE, che potrà modificare a proprio giudizio gli articoli presenti nei propri cataloghi anche qualora detti articoli siano differenti rispetto quanto risultante al CLIENTE, ferma restando la funzionalità non sia modificata.

4) Ordine, conferma d'ordine e messa in produzione

Il CLIENTE è tenuto ad accertarsi di possedere documentazione aggiornata, in quanto cataloghi e listino prezzi in vigore faranno fede in riferimento agli ordini inviati per caratteristiche e prezzi, la VENDITRICE si riserva il diritto di accettare e/o ridurre l'ordinativo a mezzo di semplice comunicazione scritta. A ricevimento dell'ordine, la VENDITRICE invierà al CLIENTE la richiesta di conferma d'ordine, non vincolante per la VENDITRICE, che non sarà obbligata di darvi corso.

5) Termini di consegna

I termini di consegna sono impegnativi per la VENDITRICE. Qualora essi non possano essere rispettati per cause di forza maggiore, la stessa si impegna ad avvertire il CLIENTE nel più breve tempo possibile. Per questo motivo il CLIENTE non potrà chiedere la risoluzione, in tutto o in parte, del contratto.

6) Trasporto

Il trasporto, e tutto ciò che esso comporta, compresi i rischi ad esso correlati, ricade sotto la responsabilità del CLIENTE quando il ritiro della merce viene fatto direttamente dal CLIENTE o quando il vettore viene scelto dallo stesso. Per consegne franco destino con mezzi scelti dall'azienda, la stessa non accetta reclami per colli danneggiati durante il trasporto se non segnalati sul DDT al momento dello scarico.

7) Garanzia

I prodotti della VENDITRICE sono garantiti contro vizi o difetti, nei limiti delle specifiche caratteristiche tecniche ed entro i normali margini di tolleranza. Il CLIENTE ha otto giorni di tempo per eventuali reclami, in caso contrario il prodotto si intenderà completamente accettato. Il CLIENTE potrà richiedere una sostituzione e/o integrazione del prodotto nel più breve tempo possibile qualora la VENDITRICE consegna per errore, riconosciuto dalla VENDITRICE un prodotto non conforme a quanto ordinato, senza che quest'ultima venga ritenuta passibile di ulteriori azioni legali. La VENDITRICE è espressamente esonerata dal fenomeno del viraggio del colore delle vernici negli elementi laccati. Danni causati durante il trasporto, o causati da una erronea installazione o manutenzione fanno decadere la garanzia. La VENDITRICE si riserva la facoltà di proporre parti di articolo, articoli o modelli ritenuti ad insindacabile giudizio della venditrice simili a prodotti difettosi coperti dalla presente garanzia, senza che la VENDITRICE sia passibile di richieste di indennizzo, compenso o risarcimento danni in alcun caso.

8) Responsabilità della VENDITRICE ed assistenza

Accessori ed apparecchiature prodotti da terzi non costituiranno responsabilità della VENDITRICE ed il CLIENTE dovrà rivolgersi direttamente alle case costruttrici, mentre i resi dovranno essere preventivamente autorizzati dalla VENDITRICE.

9) Responsabilità del CLIENTE

Il CLIENTE, qualora la VENDITRICE sospendesse gli ordinativi in corso a causa di mutamenti nella sua situazione patrimoniale tanto da inciare la sua facoltà di effettuare i relativi pagamenti, dovrà fornire la prova di aver effettuato il pagamento integrale del corrispettivo e non potrà iniziare alcuna azione contestazione.

10) Clausola risolutiva espressa

Qualora il CLIENTE non adempia ai propri obblighi tra cui il pagamento nei termini e nelle modalità concordate oppure risulti insolvente o sottoposto a procedure di fallimento, concordato preventivo o altra procedura concorsuale, la VENDITRICE potrà risolvere il rapporto ai sensi dell'art. 1456 C.C., fatti salvi il diritto di quest'ultima di sospendere l'esecuzione di cui al punto 9 delle CONDIZIONI GENERALI DI VENDITA ed ogni altra eventuale ipotesi di risoluzione per l'inadempimento ai sensi di legge. La risoluzione si verificherà con la comunicazione scritta da parte della VENDITRICE ed avrà effetto alla ricezione di detta comunicazione dal CLIENTE e potrà essere fatta valere dalla VENDITRICE, senza alcuna limitazione, anche in caso che precedentemente la VENDITRICE abbia soprasseduto di fronte agli inadempimenti del CLIENTE.

11) Legge applicabile e foro competente

Il rapporto tra la Venditrice ed il Cliente è disciplinato dal diritto Italiano. Per ogni controversia eventualmente derivante dall'interpretazione o esecuzione della presenti Condizioni Generali, o comunque connessa con il rapporto tra la Venditrice ed il Cliente sarà competente in via esclusiva il Foro della Venditrice. Per quanto non espressamente previsto dalle Condizioni Generali, valgono le norme del Codice Civile e le altre norme della Legge Italiana applicabili al rapporto.

12) Efficacia delle condizioni generali di vendita

Il CLIENTE accetta integralmente e senza riserva alcuna le presenti condizioni generali mediante la trasmissione dell'ordine e qualsiasi fornitura espletata dalla VENDITRICE al CLIENTE sarà regolata da dette condizioni.

1) General terms

What set forth below rules the relations between the SELLER and the CUSTOMER, named respectively SELLER and CUSTOMER or together THE PARTS. Different agreements compared to the General terms of Sales will not be considered as valid if not undersigned by THE PARTS.

2) Price

The selling prices for the products made by the SELLER is the current price at the moment of the scheduled delivery/collecting; the CUSTOMER must make sure of having the updated price-list. The order confirmation or any other written communication will make the BUYER aware of eventual price raises. Those price raises are at SELLER's exclusive discretion so as for the prices for any OUT OF THE CATALOGUE articles.

3) Out of the catalogue

Products or modified standard products, if any orders for out of the catalogue products will always have to be accepted by the SELLER, who can discretionally modify the articles in the catalogues, keeping the same functionality, even if those articles are different from those resulting to the CUSTOMER.

4) Order, order confirmation and putting into production

The CUSTOMER must always make sure to have the updated documentation for, as far as prices and features are concerned, current catalogues and price-lists will be the reference for the order placed. The SELLER keeps the right to accept and/or reduce the order through simple written communication. At the receipt of the order the SELLER will send to the CUSTOMER the request for the order confirmation not binding for the SELLER who will be not obliged to honour.

5) Delivery time

The SELLER reserves the faculty to modify the delivery in part or in the total and the CUSTOMER cannot ask for the termination, in whole or in part, of the contract, and as consequence the SELLER will not be liable because the delivery date is not imperative.

6) Shipment

All Shipments are EX-FACTORY unless otherwise specified. The CUSTOMER shall assume freight charges and risks of transportation in all cases even when shipments are EX-DESTINATION, including delay, damage and loss. In the absence of specific instructions, the SELLER reserves the right to select its own carrier. The SELLER will not be responsible for any claim concerning tampered, damaged or shortage of goods if not reported on the transportation documents at the moment of downloading/collecting.

7) Warranty

All products manufactured by SELLER are warranted to be free from defects in material and workmanship under normal use and service. The CUSTOMER must report within eight days claims otherwise the products will be considered as completely accepted. In case of non conforming delivery due to SELLER's acknowledged mistake, the CUSTOMER can request the replacement and/or integration of the products at the earliest available time, but the SELLER cannot be considered as liable for further legal action. The SELLER is not responsible for the colour modification of painted elements. This warranty is not valid in case of damages to the Products occurred during the transportation or occurred because of wrong installation or not proper keeping. The SELLER reserves the faculty to offer part of articles, articles or models considered by the SELLER as similar to the non conforming product covered by this warranty. In no event shall SELLER be liable for requests of compensations, indemnities.

8) SELLER's liability and assistance

Accessories and appliances produced by third parts will not be under SELLER's liability and the CUSTOMER will have to refer himself directly to the Producers, while the returns will have to be authorized by the SELLER in advance.

9) BUYER's liability

The CUSTOMER in case of SELLER's suspension of the orders in progress due to changes in its financial status that can modify his payment capacity, must supply the evidence of having placed integral payment of the amount due and cannot start legal action or contestation.

10) Breach of contract clause

In case the CUSTOMER will not honour his obligations, included the payment within the agreed terms and modalities or the CUSTOMER become insolvent or subjected to bankrupt procedures or other procedures, the SELLER can terminate the relation according to art. 1456 c.c., except for the right of the latter to suspend the execution as per point 9 of the GENERAL TERMS OF SALES and for any other case of contract terminating concerning the non-fulfillment according to the law. The termination will be done in written communication by the SELLER and will have effect starting from the receipt of the above communication from the CUSTOMER and can be used by the SELLER with no limitation, even in the case the SELLER had previously renounced to take action as consequence for the non-fulfillment by the CUSTOMER.

11) Legislation and competent court

The relation between the PARTS is ruled by Italian law. For each controversy eventually deriving from the interpretation or the execution of these General Terms of Sales or anyway connected to the relation between the PARTS the competent court will be exclusively the one of the SELLER. The Italian civil code or other Italian laws that can be applicable to the relations are valid in all the situations not expressly foreseen by this General Terms of Sales.

2) Validity of the general terms of sales

The CUSTOMER acknowledges and accepts integrally and with no reserves the present General Terms of Sales through the transmission of the order, and any supply done by the SELLER to the CUSTOMER will be ruled by above conditions.

FINITURE STRUTTURA / STRUCTURE FINISHES

STR Structure

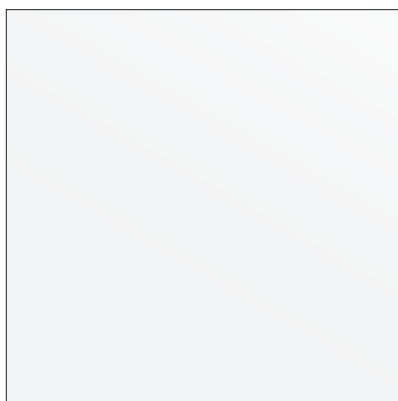

Bianco LN



Grigio AT

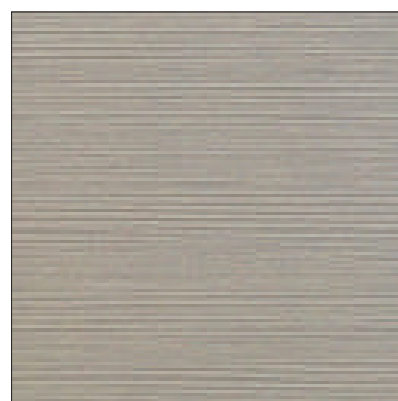

Tessuto TL

ARMADIO ANTA BATTENTE / SWING DOORS WARDROBE

COLLECTION

BATTENTE / SWING DOOR

DIMENSIONI DIMENSIONS

4 Altezze /
4 Heights

mm.2270
mm.2430
mm.2590
mm.2750

7 Larghezze /
7 Widths

mm.278
mm.428
mm.478
mm.578
mm.878
mm.978
mm.1178

Profondità /
Depth

fianco / Side Panel
mm.586

MODULI SPECIALI SPECIAL MODULES

Terminale/ Terminal
mm.340

Angolo/ Corner
mm.1026

SPAZIO PER IL MONTAGGIO / SPACE FOR ASSEMBLY

IN ALTEZZA:
1 cm. in più dell'altezza dell'armadio.
IN LARGHEZZA:
5 cm. in più della larghezza
dell'armadio.
IN HEIGHT:
1 cm. higher than wardrobe
IN WIDTH: 5 cm. more than the
wardrobe width.

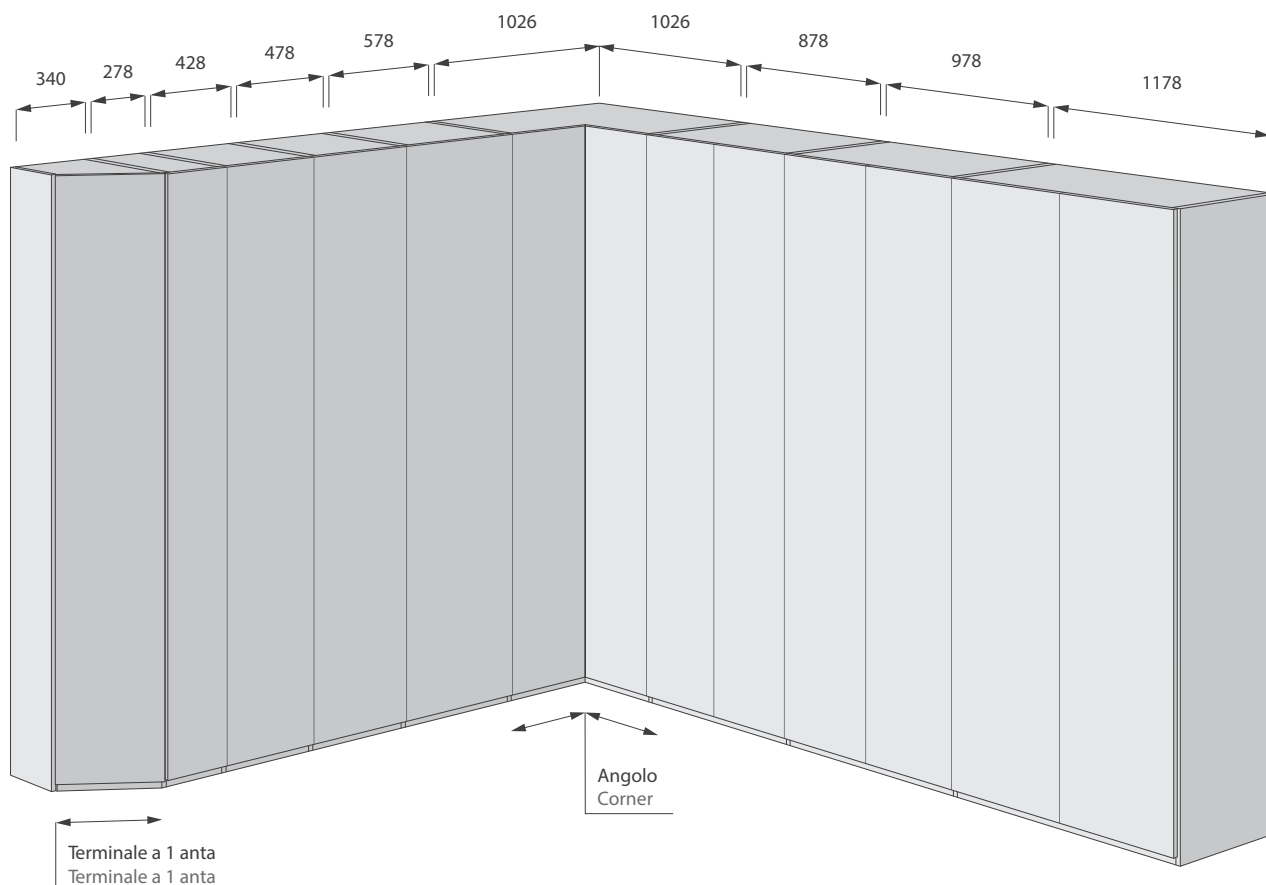

**FIANCHI /
SIDE PANELS**

Sono di spessore mm. 22.
Vengono forati ogni 160 mm. per il
posizionamento dei ripiani spostabili.
Thickness 22 mm, hole distance
160mm for removable shelves. Bottom
adjustable feet.

**FIANCHI e TRAMEZZI /
EXTERNAL AND PARTITION SIDE PANELS**

Finiture: bilaminato bianco LN
bilaminato tessuto TL
bilaminato grigio AT
Finishes: bilaminate white LN
bilaminate fabric TL
bilaminate grey AT

**FIANCHI ESTERNI /
EXTERNAL SIDE PANELS**

Lato interno nella stessa finitura
del lato esterno.
Internal and external side panel in the
same finish.

**FIANCO DI FINITURA INTEGRATO /
INTEGRATED SIDE PANEL**

Lato interno in finitura struttura,
lato esterno in finitura anta
Internal side panel in carcass finish,
external side panel in door finish.

**FIANCO DI FINITURA ESTERNO /
ADDITIONAL SIDE PANEL**

In finitura anta.
Same finish as door.

**RIPIANI /
SHELVES**

Sono di spessore mm. 30.
Finiture: bilaminato bianco LN
bilaminato tessuto TL
bilaminato grigio AT
Shelves are in bilaminate 30mm
Finishes: bilaminate white LN
bilaminate fabric TL
bilaminate grey AT

**CAPPELLO E BASE /
TOP AND BOTTOM**

Sono di spessore mm. 22.
Finiture: bilaminato bianco LN
bilaminato tessuto TL
bilaminato grigio AT
Top and bottom panels are in
bilaminate 22 mm.
Finishes: bilaminate white LN
bilaminate fabric TL
bilaminate grey AT

**SCHIENE /
BACK PANEL**

Sono di spessore mm. 8.
Finiture: bilaminato bianco LN
bilaminato tessuto TL
bilaminato grigio AT
Back panels are in thickness 8mm.
Finishes: bilaminate white LN
bilaminate fabric TL
bilaminate grey AT

**ZOCCOLO /
PLINTH**

Altezza mm. 60.
Height is 60 mm.

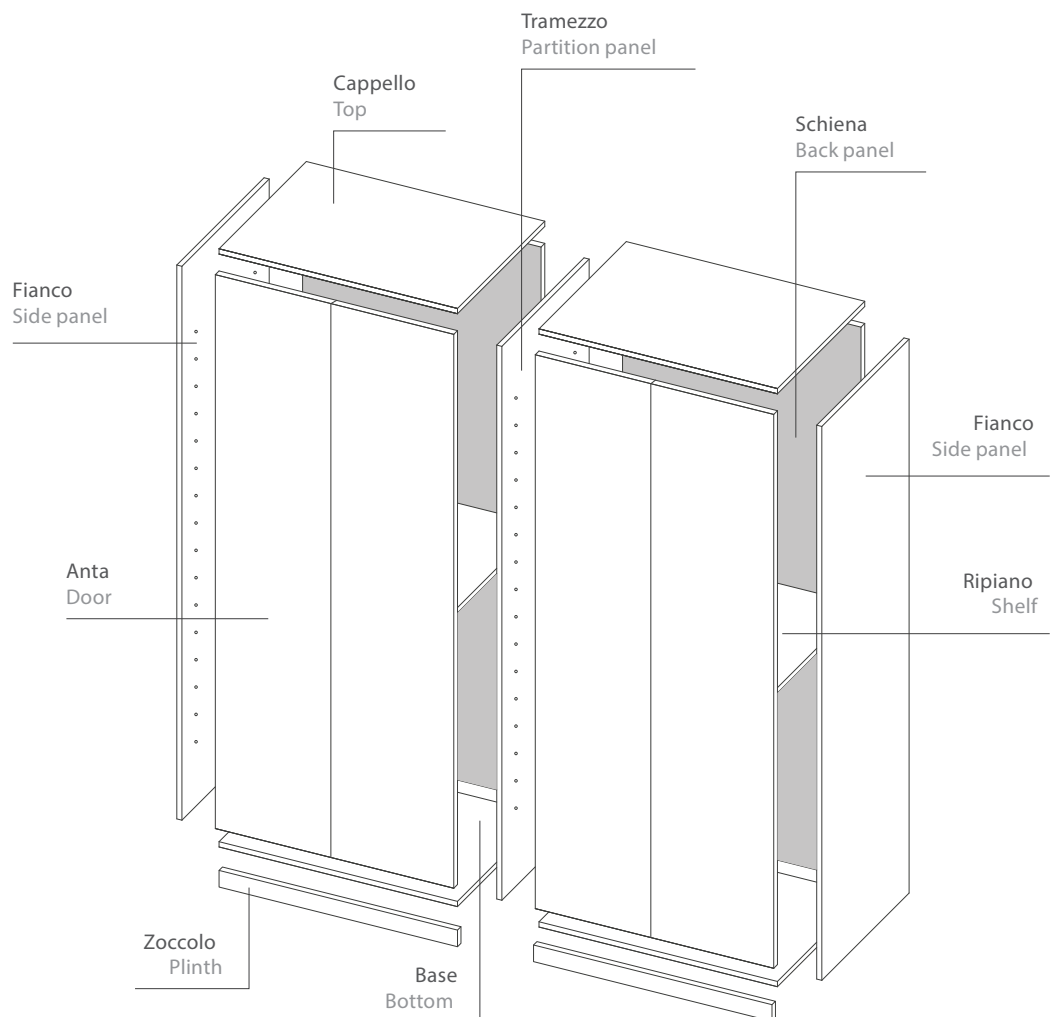

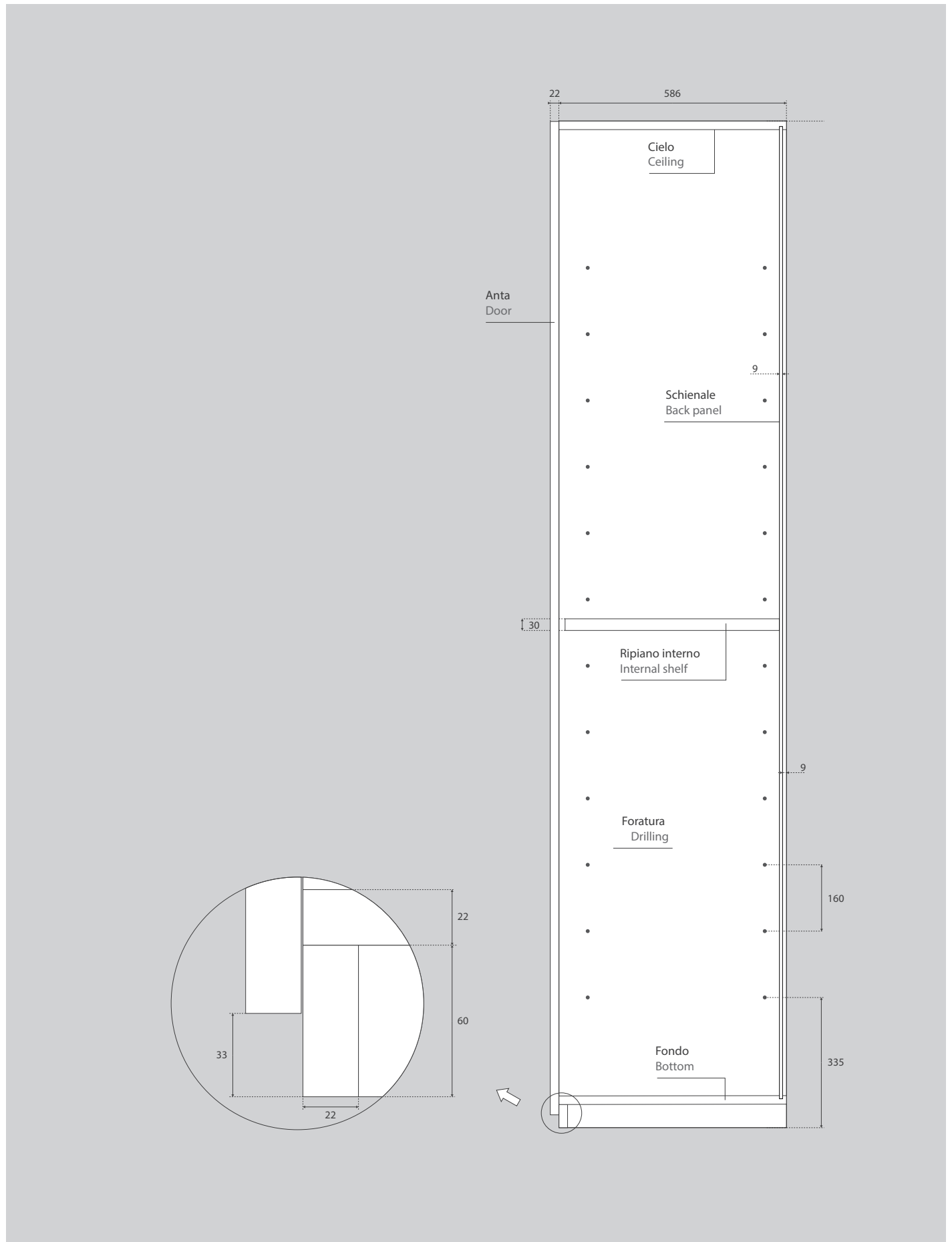

MODELLI ARMADIO BATTENTE



SWING DOORS MODELS

BATTENTE / SWING DOOR

FLAT

L'anta è completamente liscia.
Disponibile con apertura push-pull,
maniglia esterna, maniglia ad incasso. Nelle
composizioni a due ante, la maniglia viene
proposta solo sull'anta destra.

The door is completely flat.
The opening is by push-pull, external
or built in handle. In double swing door
compositions, the handle is proposed only
on the right door.

SPESSORE ANTA
DOOR THICKNESS

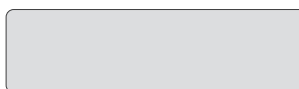

22



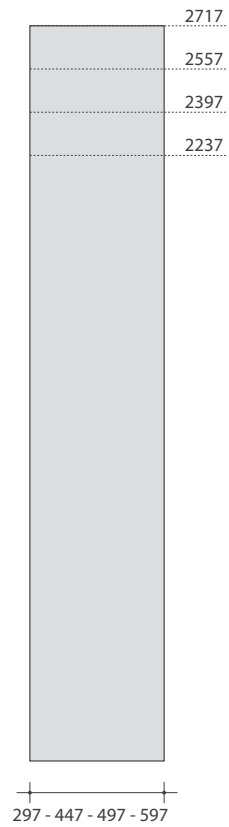
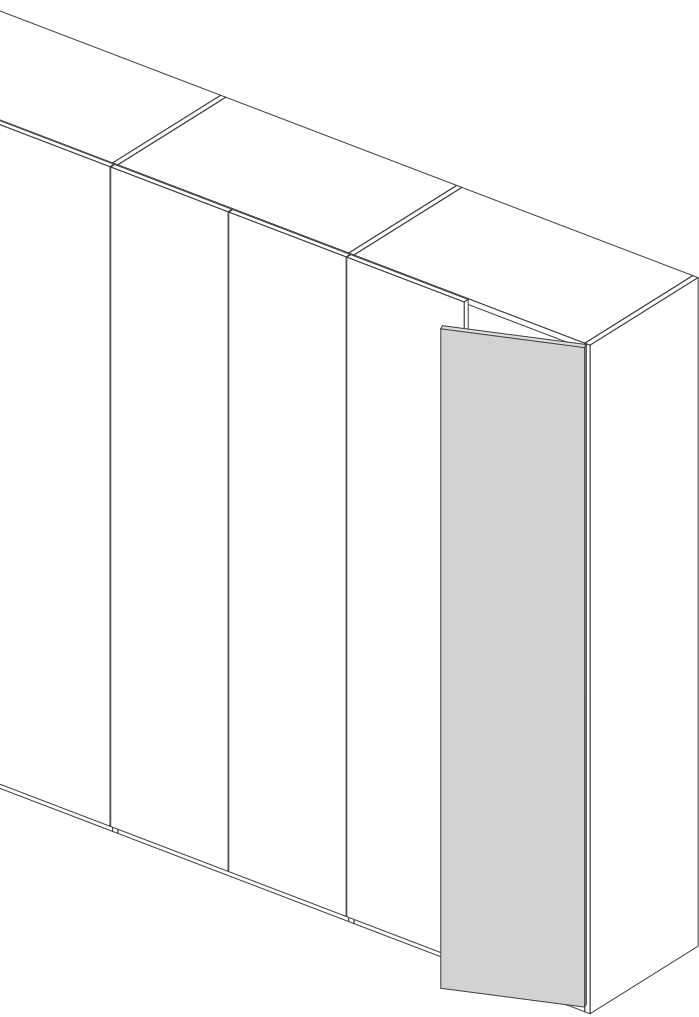

FINITURE ANTA / DOOR FINISHES

BLT - BILAMINATE
BLT - BILAMINATE

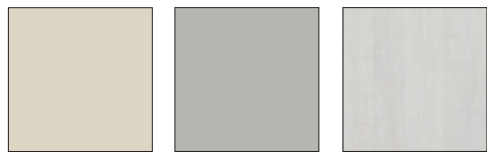

Grigio MO Grigio FO Flash GR



Flash TB Yose CH Yose SC



Millennium WH Millennium VS Rovere RB

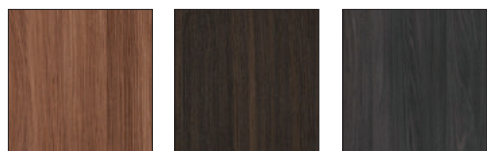

Noce LC Rodin OL Olmo LV

LOP - LACCATO OPACO
LOP - MATT LACQUERED

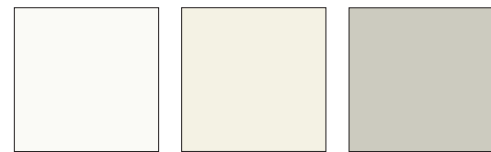

Titan WH Avorio OP Sahara BG



Grigio BX Cappuccino LO Grigio LV



Caffè OP Ferro OP Rosso PP



Blue IK Grigio AT

RAL
+ 300 €
a composizione /
each order

FLAT - BATTENTE / SWING DOOR

FINITURE ANTA / DOOR FINISHES

MUV - MONOLACCATO LUCIDO
MUV - ONE SIDE GLOSSY



Bianco LN

Grigio MR

Visone

LEG - IMPIALLACCIATO
LEG - WOOD VENEER



Rovere NT

Rovere FM

Frassino GR

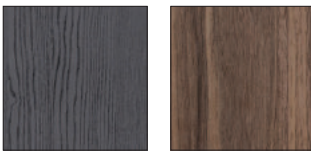

Frassino WV

Noce CN

LEE -IMPIALLACCIATO ESOTICO
LEE -WOOD VENEER EXOTIC

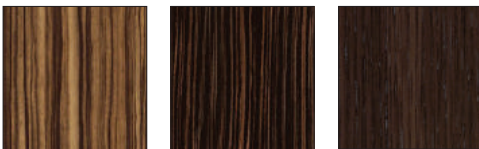

Palissandro

Ebano

Rovere TC

LEL -IMPIALLACCIATO ESOTICO LUCIDO
LEL -WOOD VENEER EXOTIC GLOSSY



Palissandro

Ebano

FLAT

MIRAGE

L'anta è in Bilaminato finitura Frassino, laccato due lati opaco. Disponibile con apertura push-pull, maniglia esterna e maniglia ad incasso. Nelle composizione a due ante, la maniglia viene proposta solo sull'anta destra.

Door is in Bilaminate Ash woodgrain matt lacquered on two sides. The opening is by push-pull, external or built in handle. In double swing door composition, the handle is proposed only on the right door.

SPESSORE ANTA
DOOR THICKNESS



FINITURE ANTA / DOOR FINISHES

FMR - LACCATO OPACO
FMR - MATT LACQUERED



Bianco



Ghiaccio

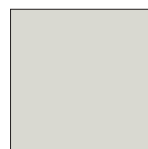

Corda

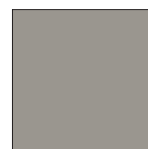

Visone

Metric

Verticale / Vertical

Finiture / Finishes	L.	Codice / Code	Punti / Points
Cromo Lucido Chrome	1000	MFB01	18

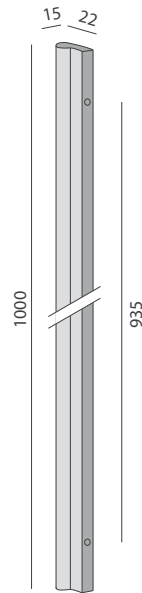
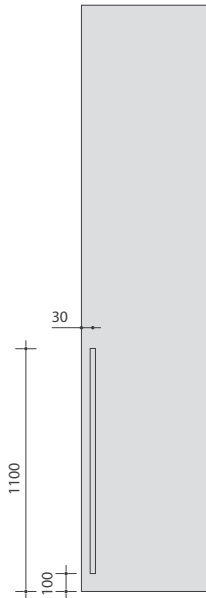

Bow

Verticale / Vertical

Finiture / Finishes	L.	Codice / Code	Punti / Points
Cromo Lucido / Chrome	1000	MFB05	18

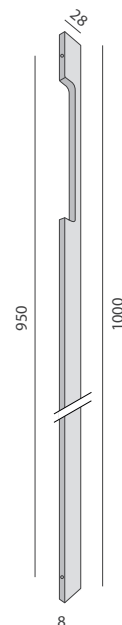
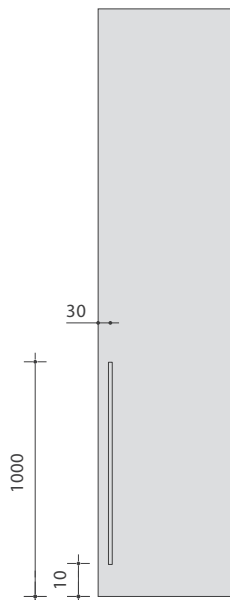

Box

Orizzontale / Horizontal

Finiture / Finishes	L.	Codice / Code	Punti / Points
Acciaio / Chrome Steel	180	MFB03	26

Finiture / Finishes	L.	Codice / Code	Punti / Points
Bianco / White	180	MFB03B	18

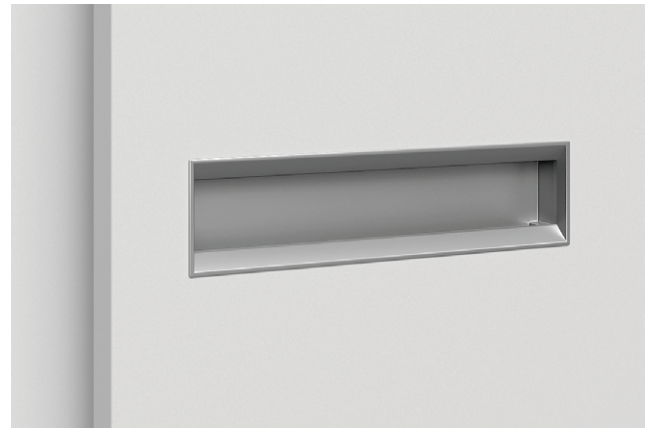
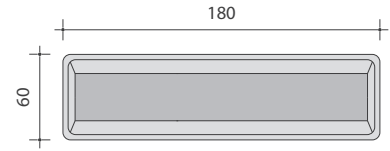
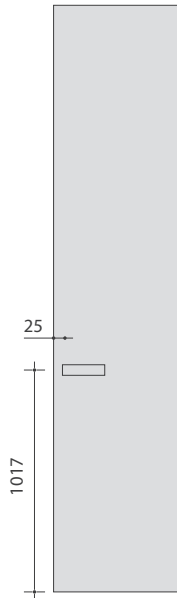

Hollow

Orizzontale / Horizontal

Finiture / Finishes	L.	Codice / Code	Punti / Points
Acciaio Fondo fin. Anta / Steel Deep finish live door	200	MFB04	42

* Non disponibile per BLT - MUV - GUV.

* Not available for BLT - MUV - GUV.

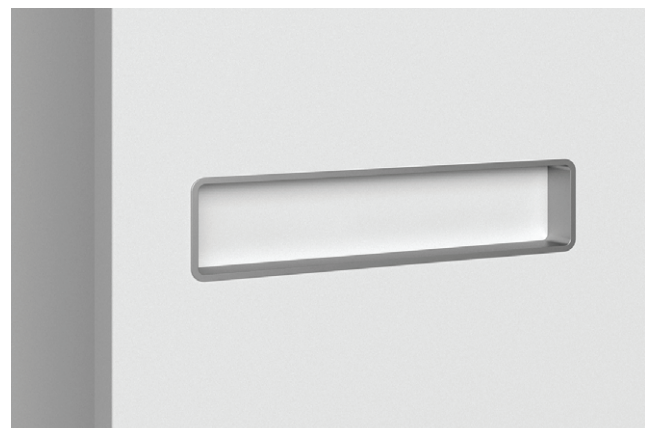
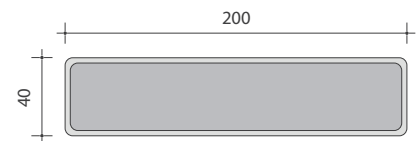
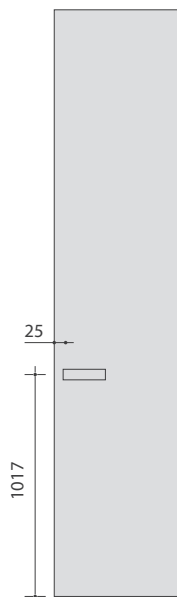

Staff

Verticale / Vertical

Finiture / Finishes	L.	Codice / Code	Punti / Points
Acciaio	180	MFB11	21
spazzolato / Brushed Steel	500	MFB12	32
	1000	MFB13	43

Finiture / Finishes	L.	Codice / Code	Punti / Points
Titanio / Titanium	180	MFB14	16
	500	MFB15	21
	1000	MFB16	32

Finiture / Finishes	L.	Codice / Code	Punti / Points
Bianco / W	180	MFB14	16
	500	MFB15	21
	1000	MFB16	32

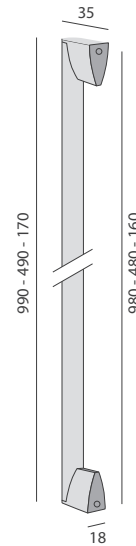
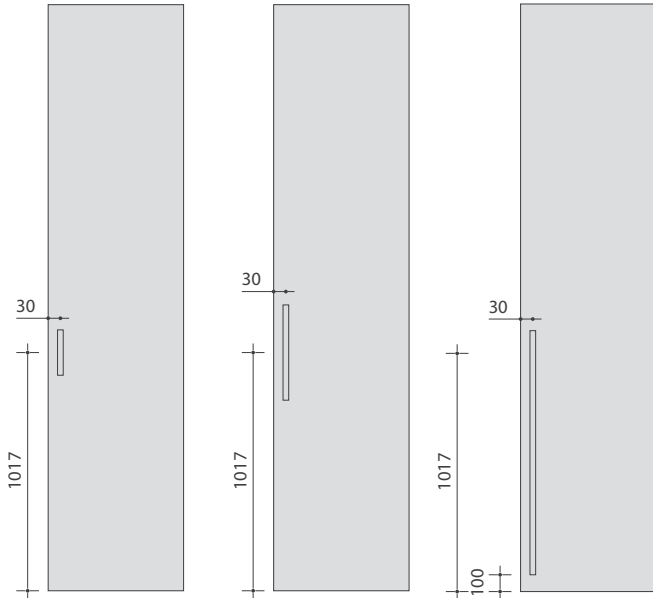

Bar

Verticale / Vertical

Finiture / Finishes	L.	Codice / Code	Punti / Points
Laccato Opaco / Matt Lacquered	200	MFB20	32
	400	MFB21	43
	1100	MFB22	64

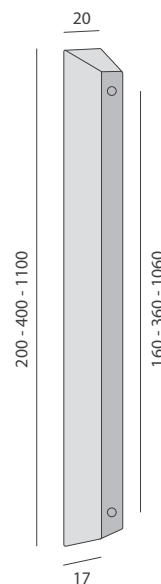
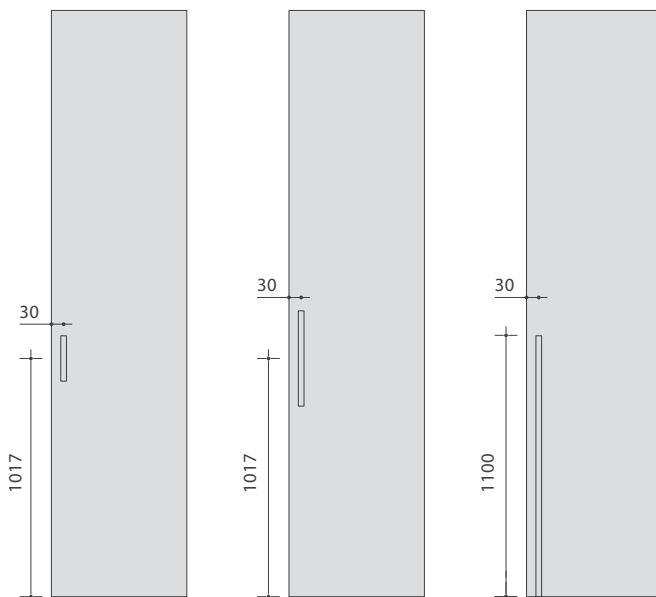

Tune

Verticale / Vertical

Finiture / Finishes	L.	Codice / Code	Punti / Points
Cromo Lucido / Chrome	180	MFB07	13
	500	MFB08	26

Finiture / Finishes	L.	Codice / Code	Punti / Points
Titanio / Titanium	180	MFB09	13
	500	MFB10	26

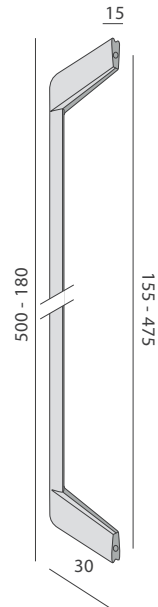
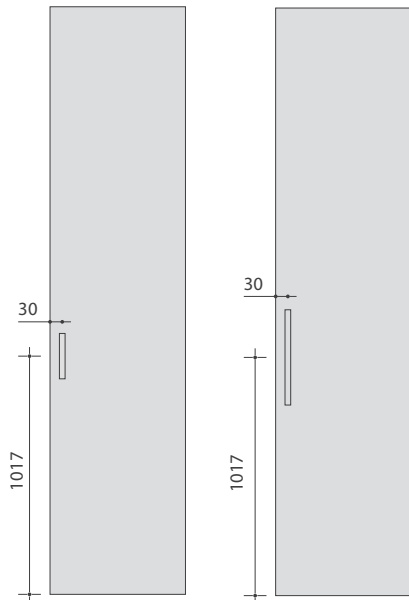

Sharp

Verticale / Vertical

Finiture / Finishes	L.	Codice / Code	Punti / Points
Cromo Lucido / Chrome	208	MFB02	11

Push-Pull

Verticale / Vertical

Codice / Code	Punti / Points
MFB06	9

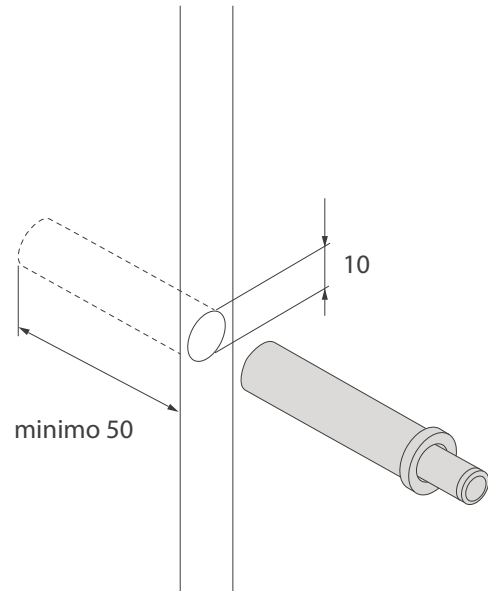
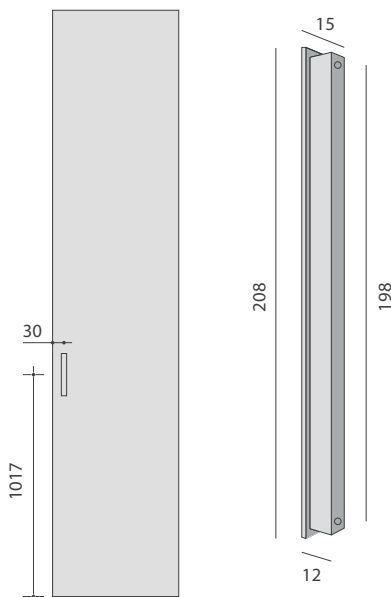

BATTENTE / SWING DOOR

GROOVE

Anta in MDF da 22mm con fondo polyester e laccatura in poliuretano opaco. Il lato di apertura ha una gola pantografata. Il retro e' in bilaminato in tinta.

22mm MDF door with bottom PE base and PU matt lacquer paint, opening side has a U shaped groove that allows door opening. Back side in bilaminate same color.

SPESSORE ANTA
DOOR THICKNESS



HALF GROOVE

HALF GROOVE

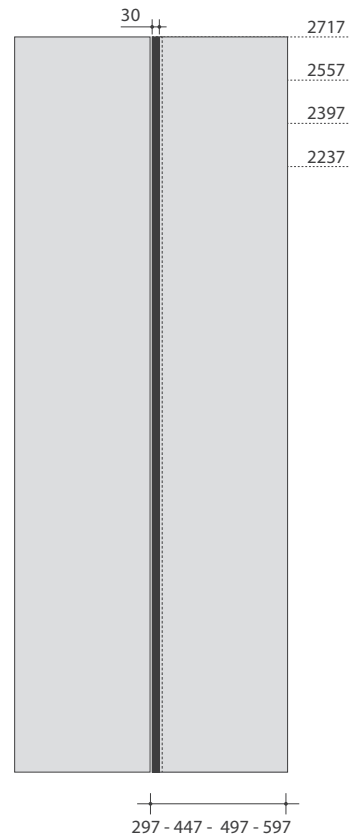

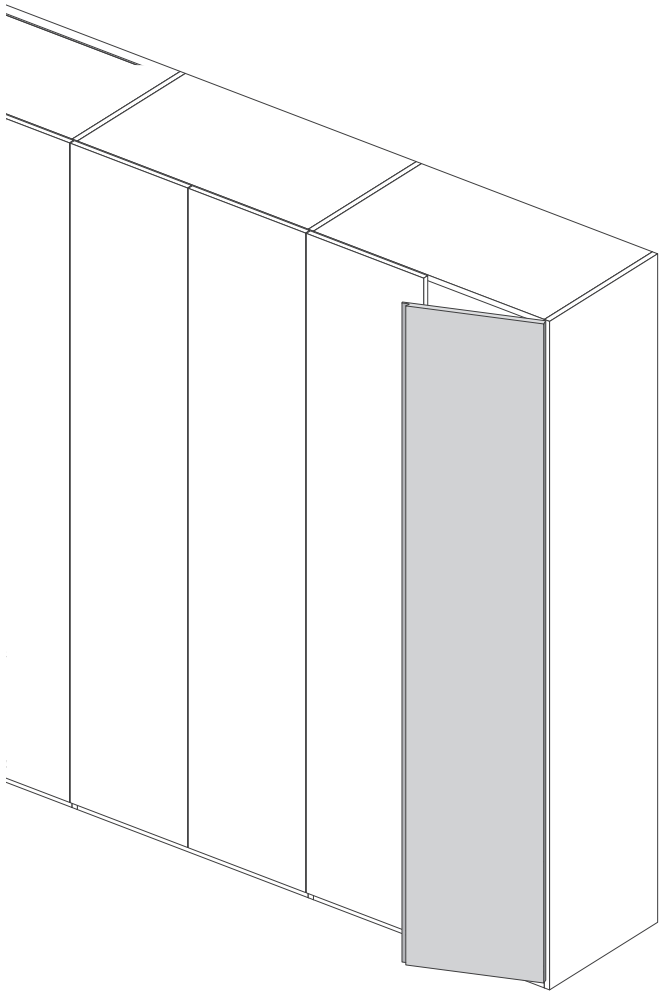

FULL GROOVE

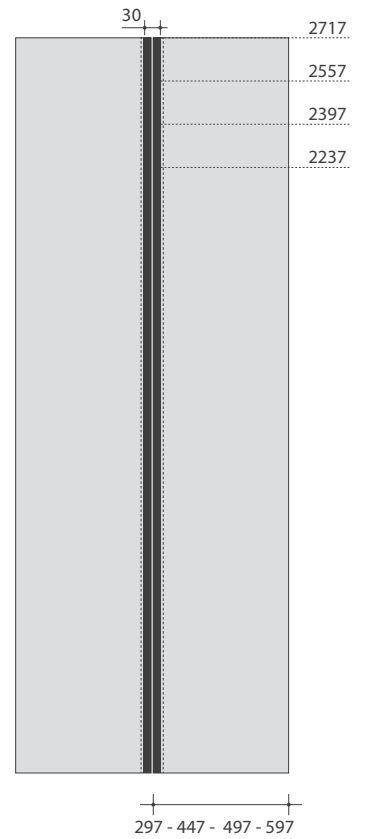

FULL GROOVE



FINITURE ANTA / DOOR FINISHES

MOP - MONOLACCATO OPACO
MOP - ONE SIDE MATT



Bianco

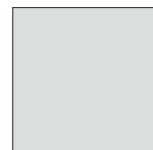

Ghiaccio

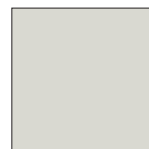

Corda



Grafite

BATTENTE / SWING DOOR

MISTY

L'anta è completamente liscia ed ha un maniglione in alluminio a tutt'altezza sul lato di apertura. Nelle composizioni a due ante la maniglia viene proposta solo sull'anta destra. Il profilo è nero sull'anta in bilaminato e laccata a colore nella versione laccato opaco.

The door is completely flat and has on the opening side a full height aluminium handle profile. In double swing door compositions, the handle is proposed only on the right door. Handle profile is available in black on bilaminate finishes and tone on tone on matt lacquered finishes.

SPESSORE ANTA
DOOR THICKNESS

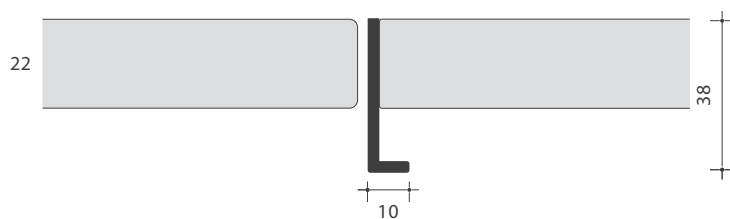

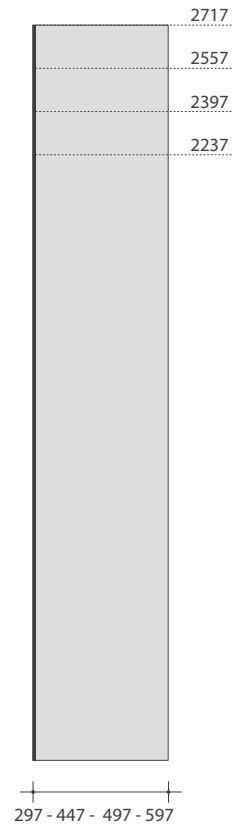
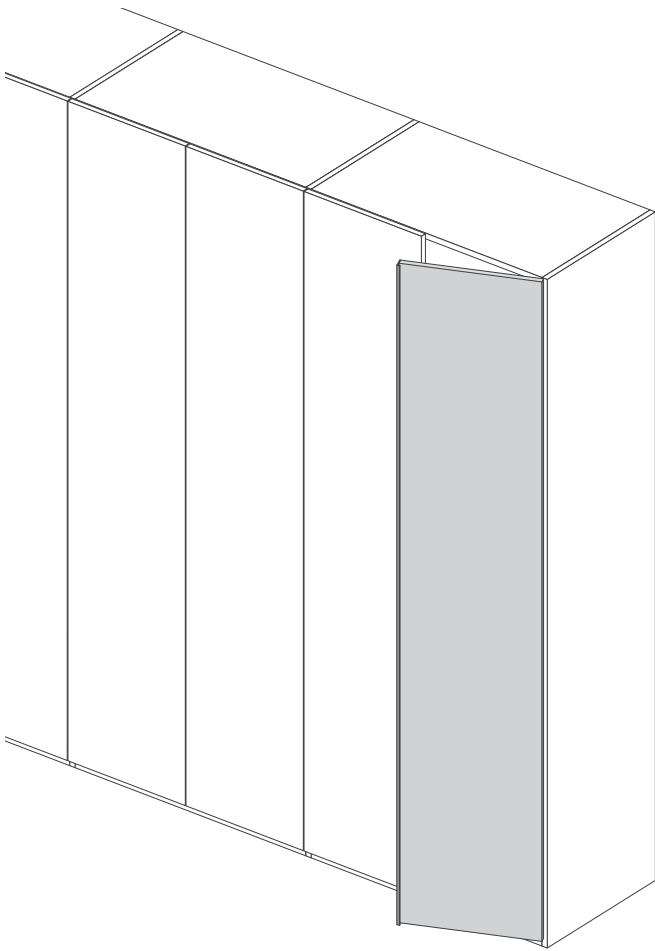

FINITURE ANTA / DOOR FINISHES

FINITURE ANTA E MANIGLIA / DOOR AND HANDLE FINISHES

BLT - BILAMINATE
BLT - BILAMINATE

LOP - LACCATO OPACO
LOP - MATT LACQUERED

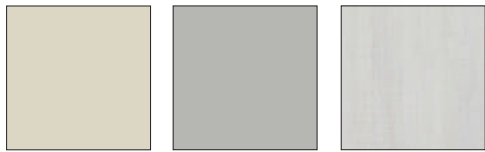

Grigio MO Grigio FO Flash GR



Flash TB Yose CH Yose SC



Millennium WH Millennium VS Rovere RB

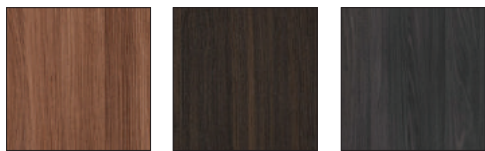

Noce LC Rodin OL Olmo LV

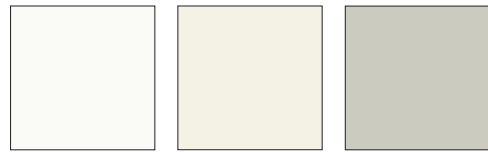

Titan WH Avorio OP Sahara BG



Grigio BX Cappuccino LO Grigio LV



Caffè OP Ferro OP Rosso PP



Blue IK Grigio AT

RAL
+ 300 €
a composizione /
each order

BATTENTE / SWING DOOR

GAP

L'anta è completamente liscia ed ha incassato un maniglione in alluminio con gola a tutt'altezza sul lato di apertura. Nelle composizioni a due ante la maniglia viene proposta solo sull'anta destra. Il profilo è nero sull'anta in bilaminato e laccato a colore nella versione laccato opaco.

The door is completely flat and has on the opening side built-in full height aluminium groove profile. In double swing door composition, the handle is proposed only on the right door. Handle profile is available in black on bilaminate finishes and tone on tone on matt lacquered finishes.

SPESSORE ANTA
DOOR THICKNESS

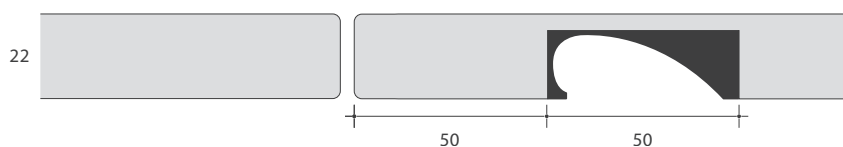

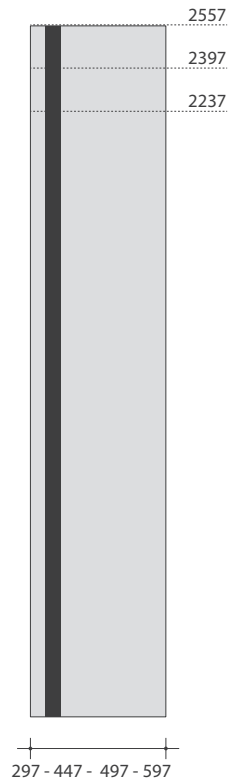
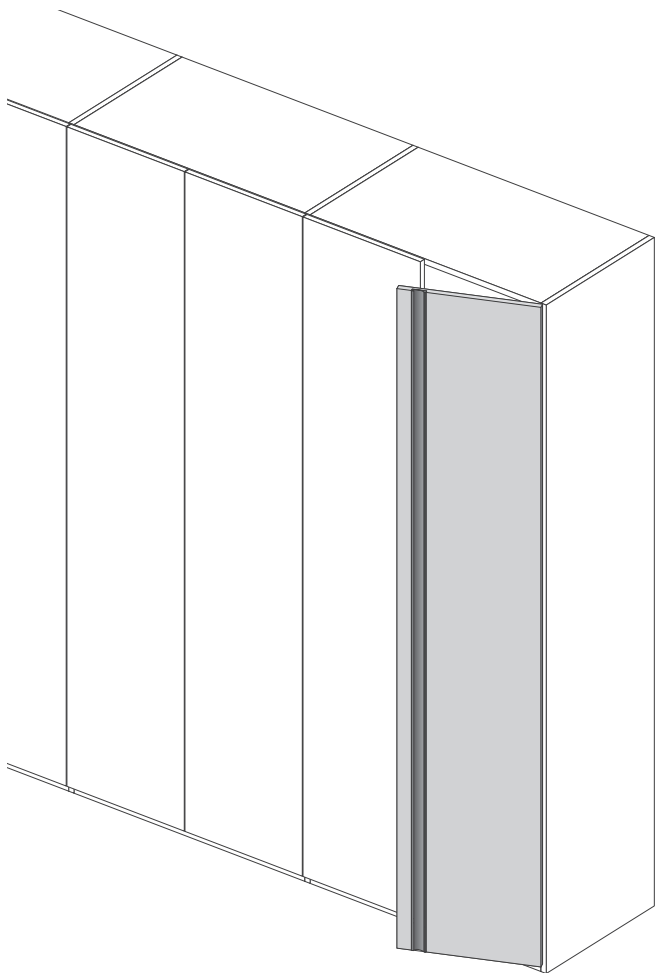

FINITURE ANTA / DOOR FINISHES

BLT - BILAMINATE
BLT - BILAMINATE

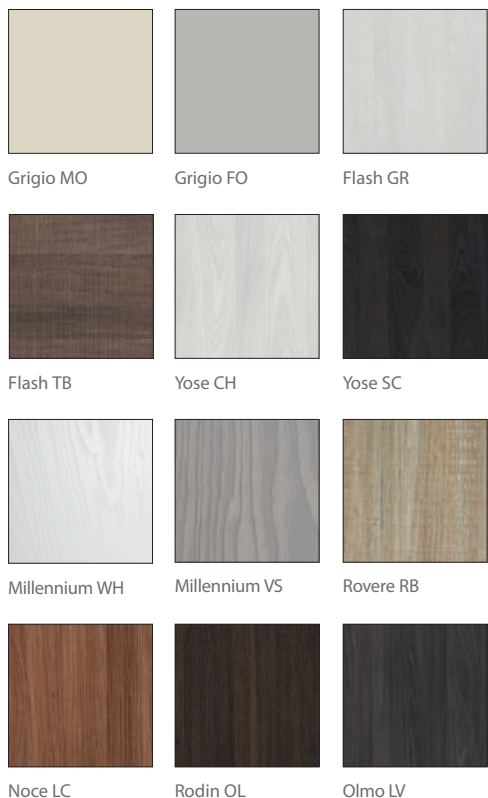

LOP - LACCATO OPACO
LOP - MATT LACQUERED

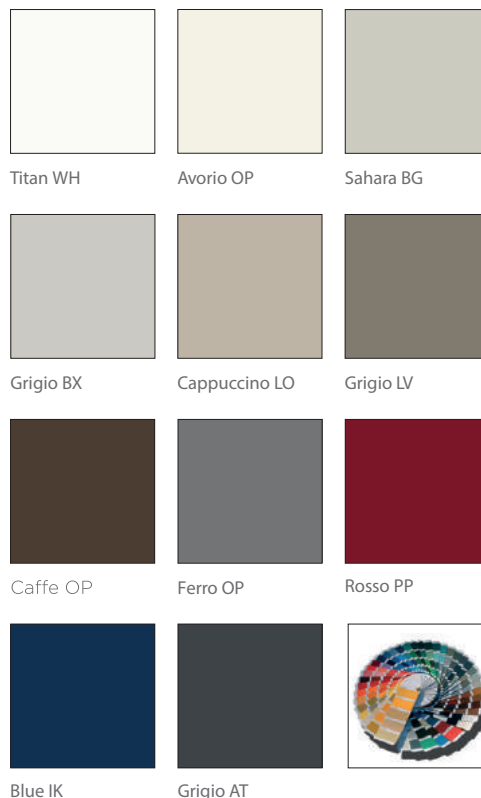

RAL
+ 300 €
a composizione /
each order

BATTENTE / SWING DOOR

STAGE

Anta in MDF da 22mm disponibile in finitura laccata opaca. Ha una maniglia arretrata ed intercambiabile sul lato di apertura.

22mm MDF door with available in matt lacquered finish. Has a recessed and interchangeable handle on the opening side.

SPESSORE ANTA
DOOR THICKNESS



22



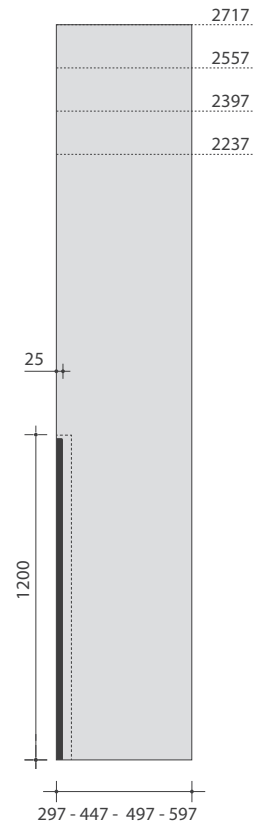
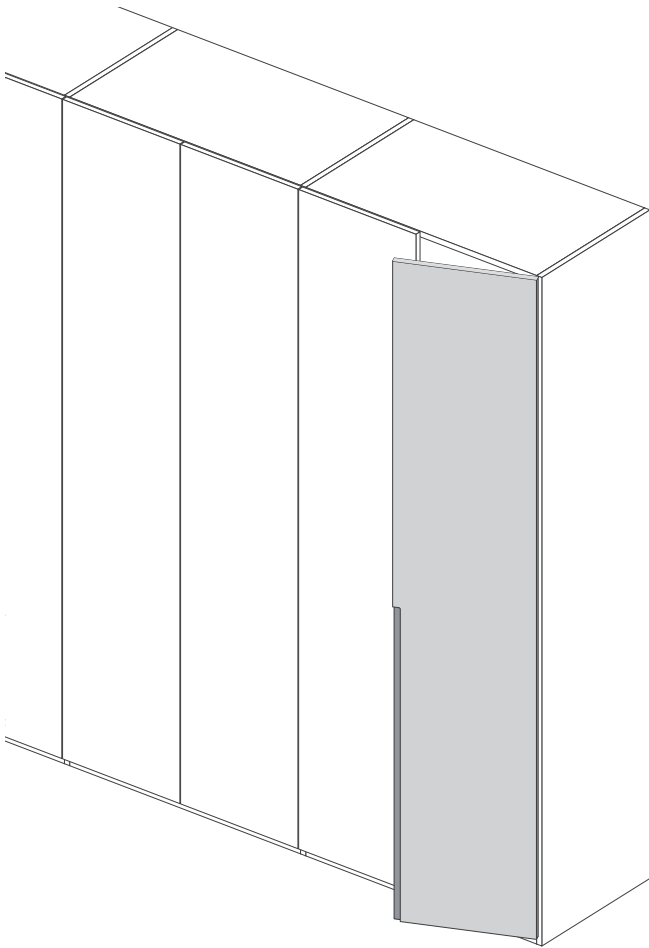

FINITURE ANTA / DOOR FINISHES

LOP - LACCATO OPACO
LOP - MATT LACQUERED

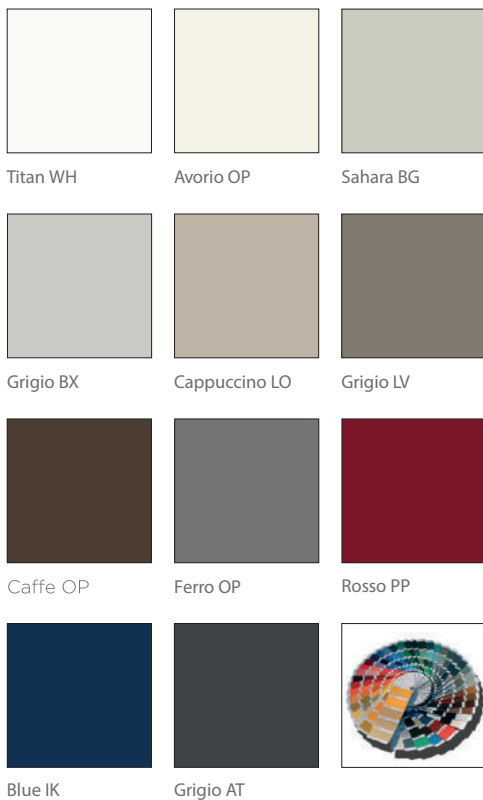

FINITURE MANIGLIE / HANDLE FINISHES

LOP - LACCATO OPACO
LOP - MATT LACQUERED



BATTENTE / SWING DOOR

STAGE

WOOD
EXOTIC

Anta in MDF da 22mm impiallacciata. Ha una maniglia arretrata ed intercambiabile sul lato di apertura.

22mm MDF door in veneer version. Has a recessed and interchangeable handle on the opening side.

SPESSORE ANTA
DOOR THICKNESS



22



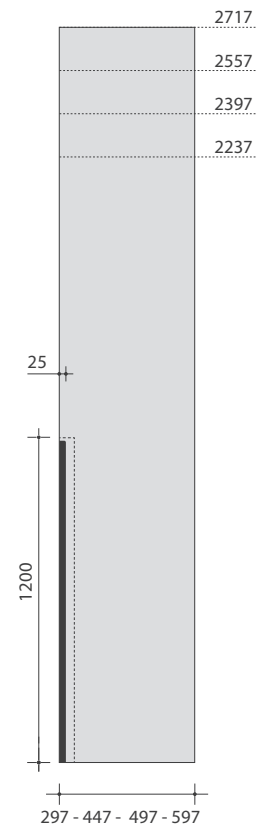
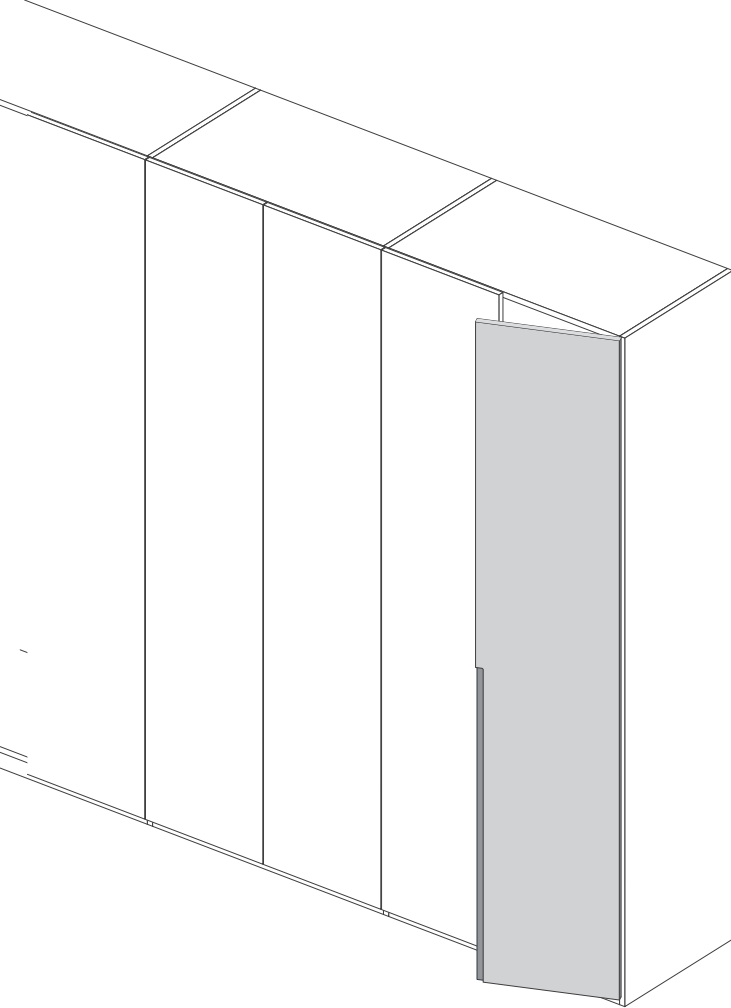

STAGE WOOD FINITURE ANTA /
STAGE WOOD DOOR FINISHES

LEG - IMPIALLACCIATO
LEG - WOOD VENEER

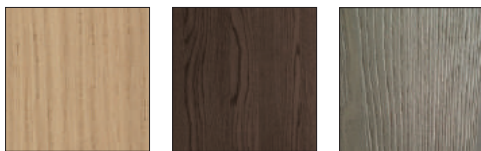

Rovere NT Rovere FM Frassino GR



Frassino WW Noce CN

STAGE EXOTIC FINITURE ANTA /
STAGE EXOTIC DOOR FINISHES

LEE - IMPIALLACCIATO ESOTICO
LEE - WOOD VENEER EXOTIC

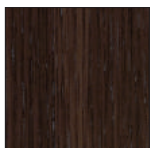

Rovere TC

FINITURE MANIGLIE / HANDLE FINISHES

LOP - LACCATO OPACO
LOP - MATT LACQUERED

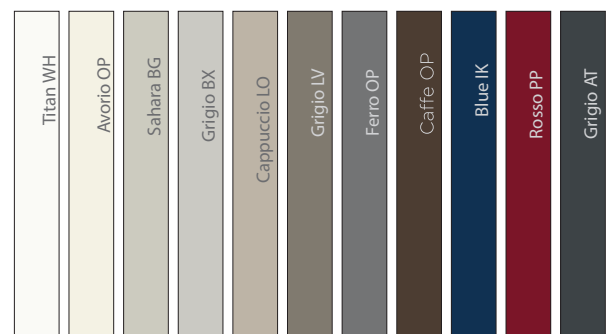

LEG - IMPIALLACCIATO
LEG - WOOD VENEER

LEE - IMPIALLACCIATO ESOTICO
LEE - WOOD VENEER EXOTIC



BATTENTE / SWING DOOR

BEBOP

Anta in MDF da 22 mm, disponibile in finitura laccata opaca e lucida. Ha una maniglia arretrata rispetto ad un foro anteriore sagomato, disponibile in varie finiture.

Door in MDF 22 mm, available in matt and glossy lacquered finishes. The handle is long curved hole with a recessed panel available in several finishes.

SPESSORE ANTA
DOOR THICKNESS

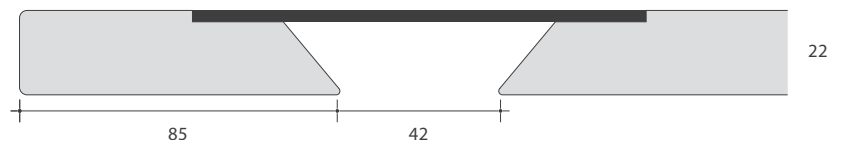

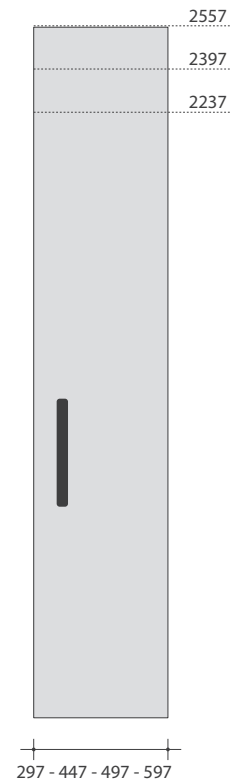
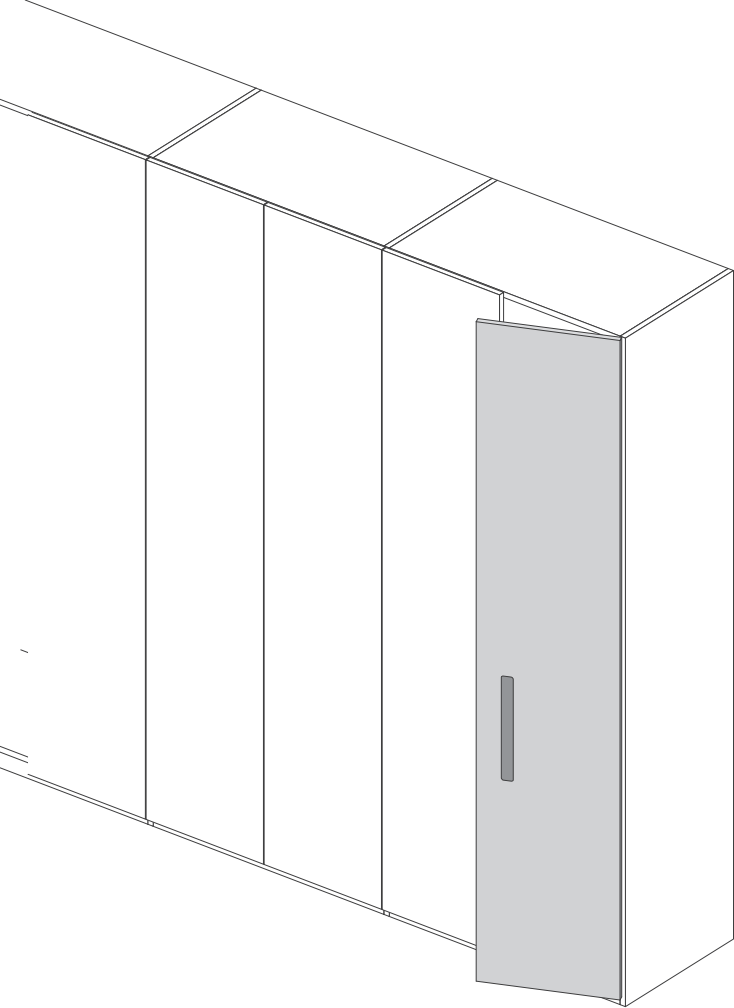

FINITURE ANTA / DOOR FINISHES

LOP - LACCATO OPACO
LOP - MATT LACQUERED

LLU - LACCATO LUCIDO
LLU - GLOSSY LACQUERED



Titan WH Avorio OP Sahara BG



Grigio BX Cappuccino LO Grigio LV



Caffè OP Ferro OP Rosso PP



Blue IK Grigio AT

RAL
+ 300 €
a composizione /
each order

FINITURE MANIGLIE / HANDLE FINISHES

LOP - LACCATO OPACO
LOP - MATT LACQUERED



LEG - IMPIALLACCIATO
LEG - WOOD VENEER

LEE - IMPIALLACCIATO ESOTICO
LEE - WOOD VENEER EXOTIC



BATTENTE / SWING DOOR

NAIMA

Anta realizzata con lastra di vetro laccato o a specchio, spessore 4 mm. e con vetro incassato all'interno del telaio in alluminio.

Alluminium door with 4 mm. lacquered or mirrored glass, total thickness 22 mm. Glass is inserted in the profile.

SPESSORE ANTA
DOOR THICKNESS

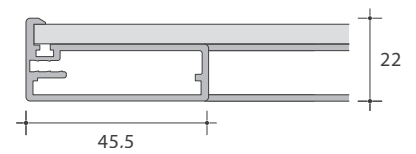

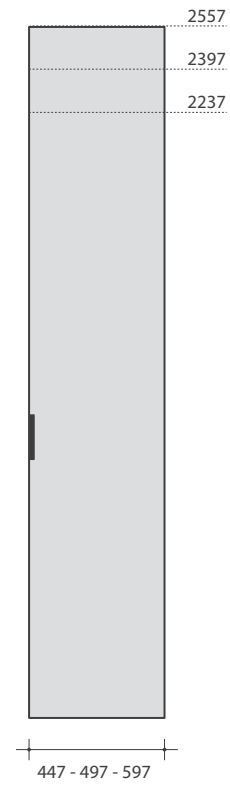
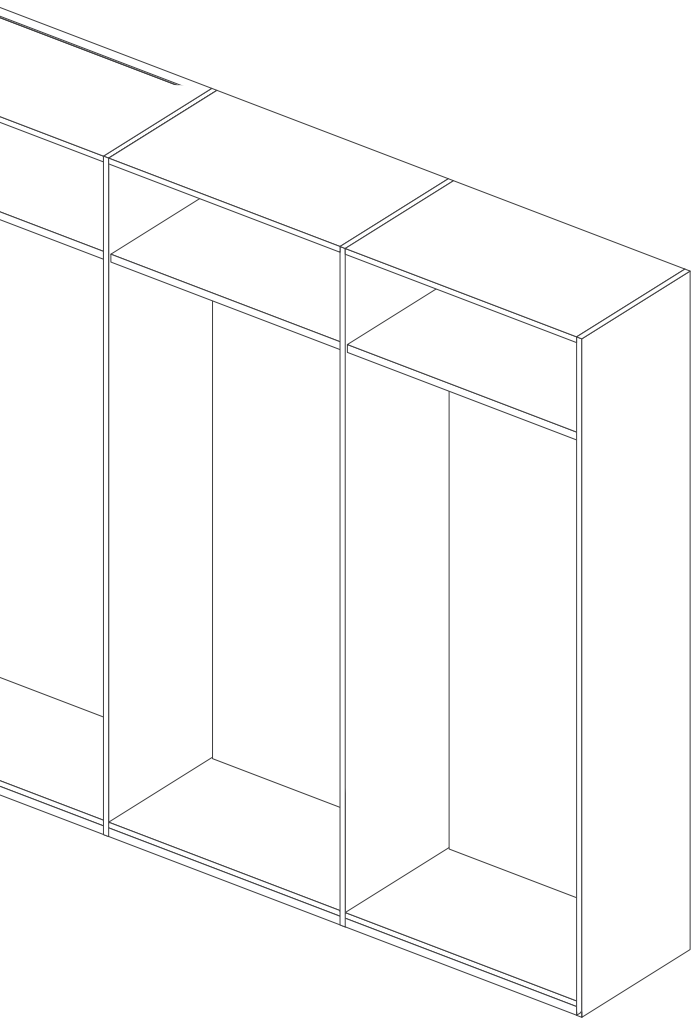

FINITURE ANTA / DOOR FINISHES

VLO - VETRO LACCATO OPACO
VLO - MATT LACQUERED GLASS

VLL - VETRO LACCATO LUCIDO
VLL - GLOSSY LACQUERED GLASS



Bianco NV



Corda

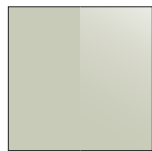

Sabbia



Rosso



Blu Oltremare



Marrone



Caffè OP



Grafite

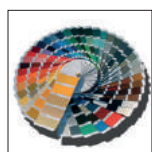

RAL
+ 300 €
a composizione /
each order

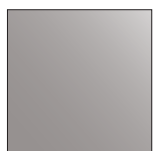

TSP - SPECCHIO
TSP - MIRROR

FINITURE TELAIO / FRAME FINISHES



Bianco OP



Nero



Alluminio ST

BATTENTE / SWING DOOR

SHINE

Anta realizzata con lastra di vetro spessore di 4 mm. Ha un telaio in alluminio con cornice sporgente per presa maniglia. Il telaio ruota su una cerniera a scomparsa con chiusura soft.

Glass door with aluminium profile and 4 mm. tempered glass. This door has a thick aluminium frame which can be used as handle. The frame works on special disappearing hinges with soft-close.

SPESORE ANTA
DOOR THICKNESS

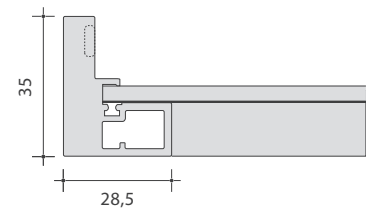

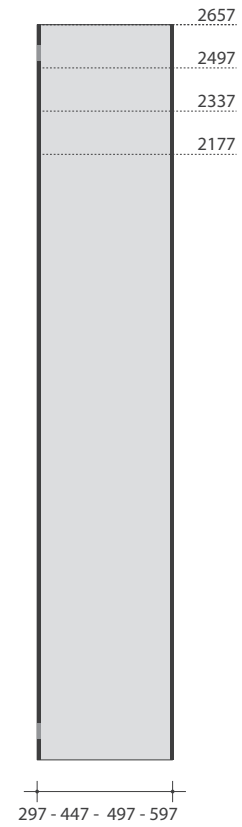
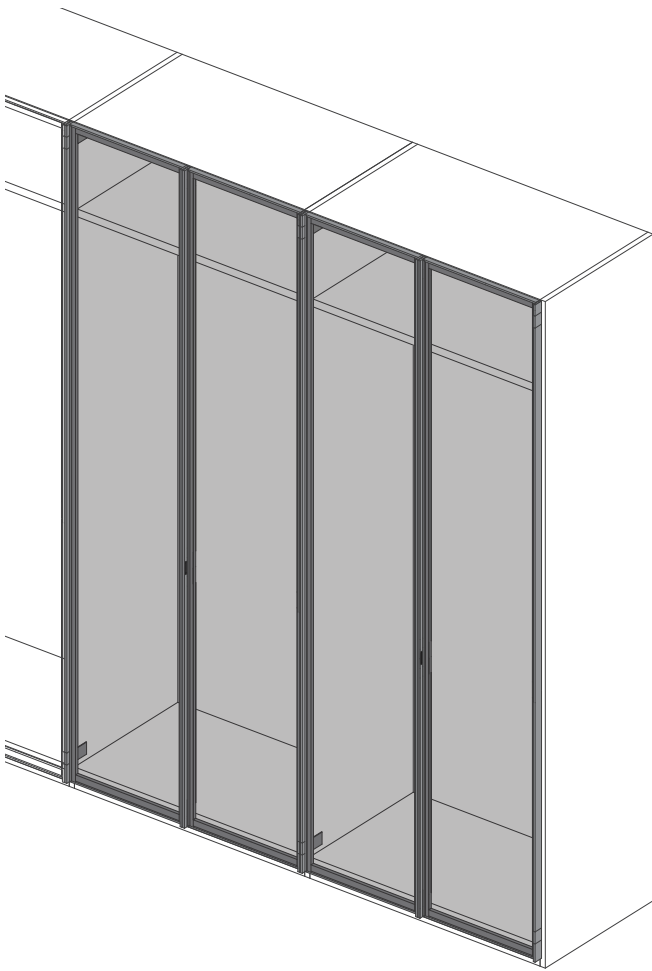

FINITURE ANTA / DOOR FINISHES

TVT -VETRO TRASPARENTE
TVT -CLEAR GLASS



Bianco LN

TSS -VETRO STOPSOL
TSS -STOPSOL GLASS



Stopsol BR

Stopsol FM

FINITURA TELAIO / FRAME FINISH



Absolute Titanio

BATTENTE / SWING DOOR

MILESTONES

Anta realizzata con lastra in gres di spessore 4 mm sostenuta da un telaio a scomparsa. Spessore totale 22 mm, l'anta Milestones è disponibile solo con apertura push-pull.

This model is produced with an aluminium framed door with a central panel in 4 mm laminated gres and has a total thickness of 22 mm. This door works only with push-open system.

SPESORE ANTA
DOOR THICKNESS

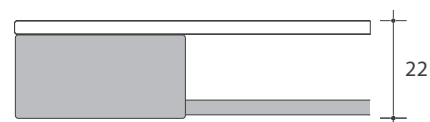

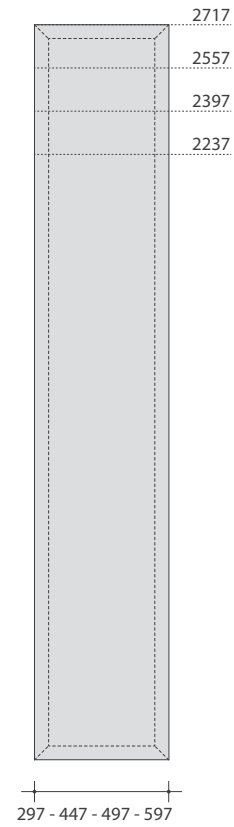
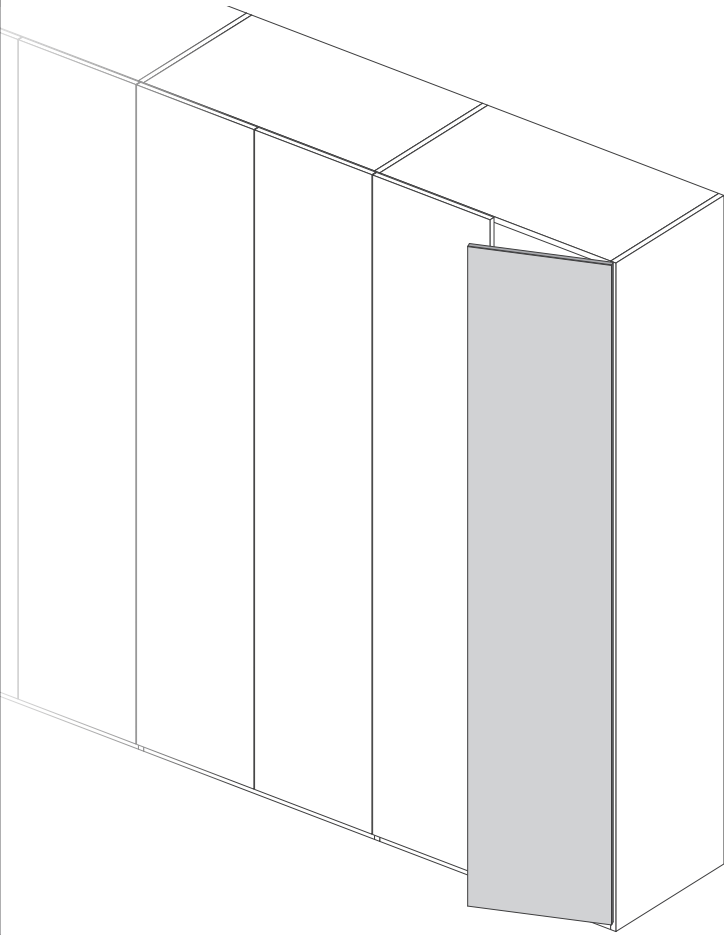

FINITURE ANTA / DOOR FINISHES

ATG - GRES
ATG - GRES

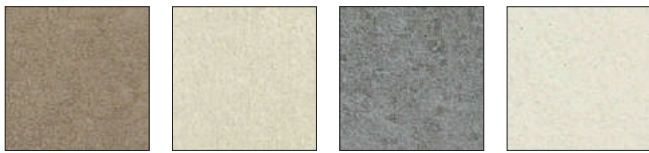

Fokos Terra Fokos Sale Savoia Grigia Oxide Bianco

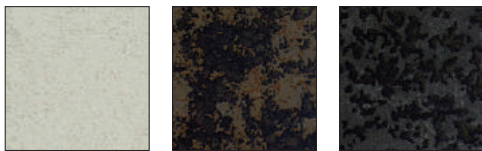

Oxide Perla Oxide Moro Oxide Nero

FINITURA TELAIO / FRAME FINISH



aluminium Satin

BATTENTE / SWING DOOR

ELLINGTON

DIAMOND

Anta rivestita in ecopelle sul lato a vista, con imbottitura di 2 mm. L'anta è suddivisa in cartelle con cuciture perimetrali a rilievo anche sui bordi. Sulla fascia centrale è incassata la maniglia anch' essa rivestita in eco pelle. Il retro dell'anta è in microfibra. Nella versione DIAMOND la fascia centrale è caratterizzata da un motivo a rombi.

Door upholstered in eco-leather and with a thin 2 mm layer of inner foam. Door is divided in regular size rectangles with a stitched perimeter. Edges are eco-leather upholstered and stiched, the retro of the doors is in black microfiber flocked material. In the DIAMOND version the central area can be divided in diamond shape stitchings.

SPESSORE ANTA
DOOR THICKNESS

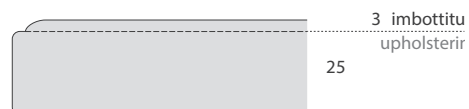

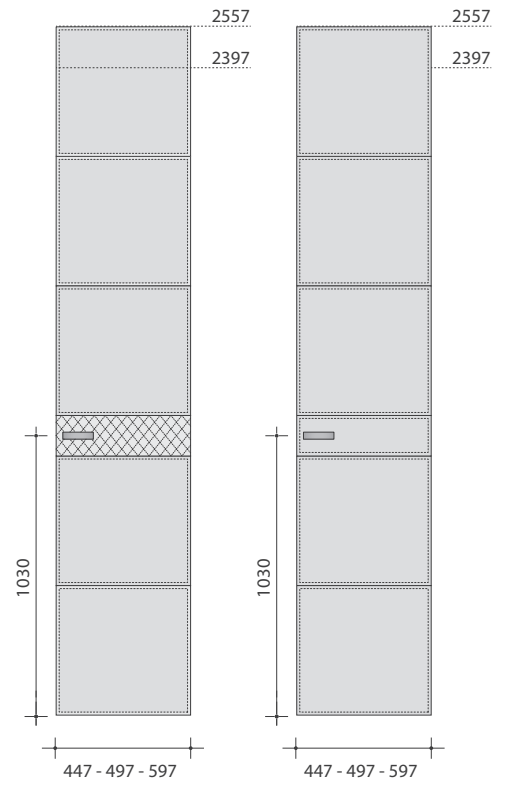
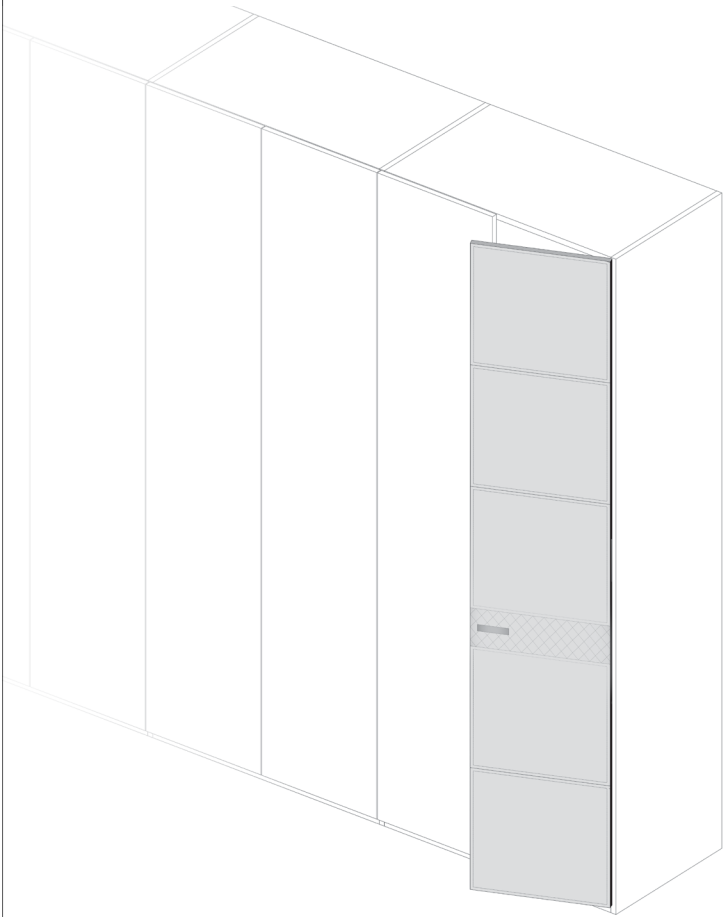

ELLINGTON
DIAMOND

ELLINGTON

FINITURE ANTA / DOOR FINISHES

ECP - ECO- PELLE
ECP - ECO-LEATHER

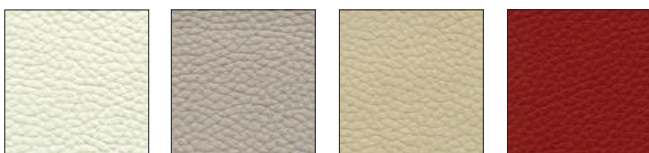

Corfù White Corfù Light Grey Corfù Toffee Corfù Red

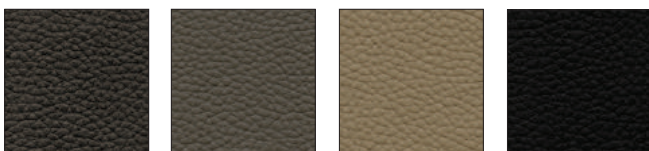

Corfù Brown Corfù Elephant Corfù Trufa Corfù Black

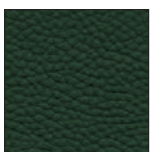

BR Green