

WALKIE

MOTORIZED PALLET TRUCK

LIFT-RITE
KEEPS YOU MOVING

LIFT SMART. LIFT EASY. LIFT-RITE.

ABOUT US

You put your heart and soul into your business. To keep moving forward, your equipment needs to be just as hardworking as you. Otherwise, your workflow stops. With Lift-Rite, you'll have one less thing to worry about. Because we provide durable, versatile and comfortable trucks to keep you moving forward.

MISSION STATEMENT

To be recognized in the marketplace as a leader providing quality, reliability, and dependability to all Lift-Rite customers.

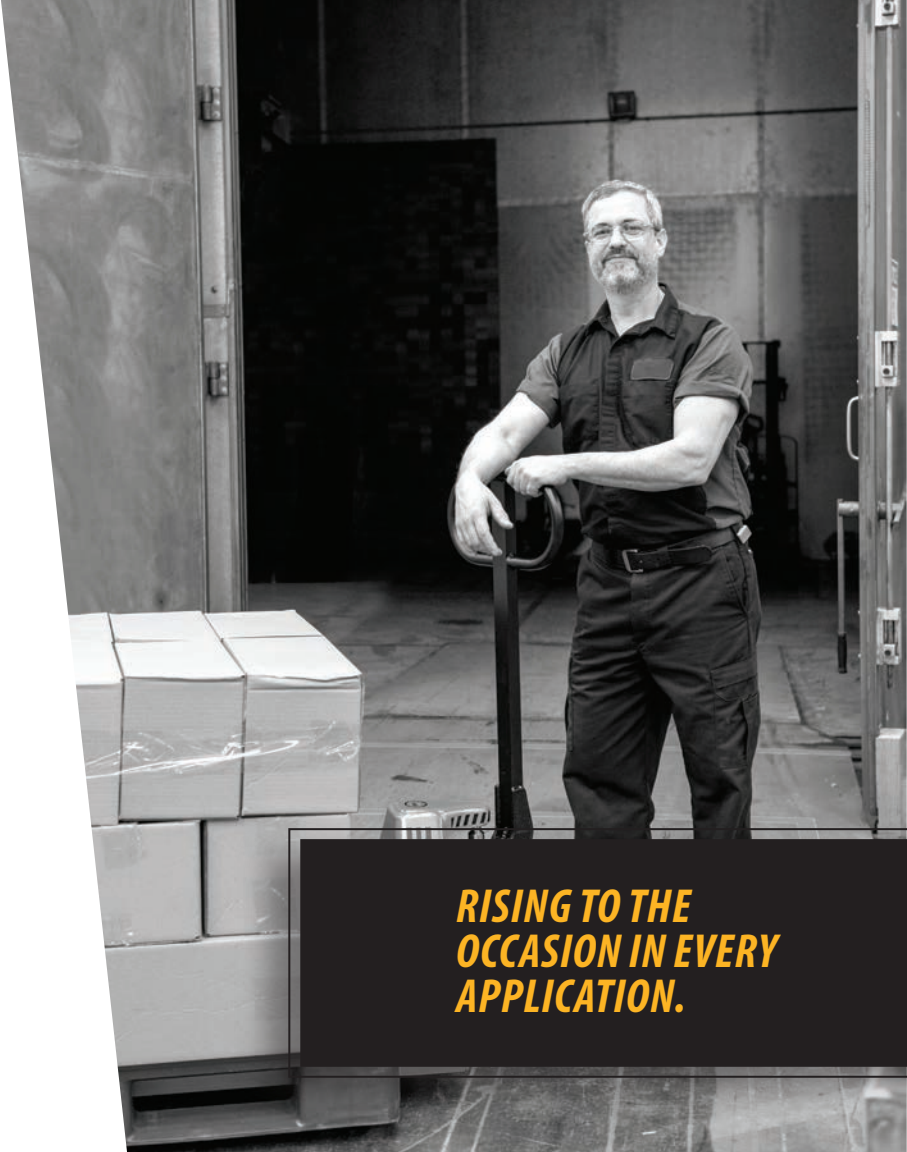

WALKIE

IDEAL FOR:

WHOLESALE
LIGHT DELIVERY
LIGHT DISTRIBUTION
MANUFACTURING
RETAIL
GROCERY

**RISING TO THE
OCCASION IN EVERY
APPLICATION.**

FLEXIBILITY. RELIABILITY. **AFFORDABILITY.**

MOVE MORE PALLETS, MORE QUICKLY

**BUILT RIGHT.
PRICED RIGHT.
LIFT-RITE.**

Simple to maintain and afford, the LRW35 from Lift-Rite makes it easy to experience the enhanced productivity of a motorized pallet truck. Ergonomically designed and economically priced, it's the ideal user-friendly, budget-friendly solution for a variety of operations and applications.



THE POWER TO GET YOU MOVING.

Powerful, reliable, and maneuverable, the Lift-Rite Walkie offers the ideal combination of ability and affordability. From retail and grocery environments to wholesale and manufacturing operations, this truck can enhance productivity in any application. Take a step up from manual pallet-handling solutions, and discover the optimized efficiency of a motorized Walkie.

MORE COMFORTABLE. MORE USABLE.

Easy to control and exceptionally maneuverable, the Lift-Rite Walkie simplifies material handling tasks around the warehouse, on the dock, or in trailers. Designed for superior operator comfort and confidence, the truck handles loads up to 3,500 lbs with minimum effort and maximum precision.

» Greater productivity with battery and truck information shown on a real-time display.

» Superior efficiency with a lift/lower cutout that prevents lifting on a low battery so the unit can be moved to a charging station.

» Enhanced operator comfort with a long, ergonomically designed tiller and easily accessible controls for left- and right-handed users.

» Faster, simpler recharging with convenient onboard charger.

» Easy startup and controlled user access with simple on/off key switch.

» Greater control in tight areas with superior maneuverability at slow speeds with the tiller upright against the truck.

MORE MAINTAINABLE. MORE RELIABLE.

Engineered to minimize maintenance requirements—and to simplify servicing when it is needed—the LRW35 offers exceptional durability for long-term reliability and productivity.

» Greater uptime with quick, easy, tool-free access to internal components.

» Faster, simpler maintenance with a battery watering system that can extend battery life and performance.

» Longer life with a rugged, simple design that eliminates extra buttons and minimizes wearable parts.

» Secure load transport and minimized wear-and-tear with durable, purpose-built stabilizers welded to the truck.

» Easy lifting and servicing with convenient built-in hoist hooks



**MORE CAPABLE.
MORE AFFORDABLE.**

With an affordable up-front price tag, the Lift-Rite Walkie lets you be both efficient and cost-efficient. Move a lot more without spending a lot more with a truck that offers uncompromising performance and unbeatable value.

- » Greater application flexibility with the perfect combination of high capacity and low cost.
- » Economical ongoing operation with low maintenance requirements and costs.

**MORE DURABLE.
MORE DEPENDABLE.**

Rugged, robust, and intelligently engineered, the Lift-Rite Walkie is a reliable workhorse offering everything you need to move more pallets, work more quickly, and operate more efficiently.

- » Faster, more convenient charging with an easily accessible, always available, self-storing charging cord.
- » Greater load stability with an optional 48" load backrest.



Precise maneuverability and speed control allow confident handling on lift gates and in tight spaces.



Onboard charger makes it easy and convenient to charge the truck so it's ready when you are.



All controls—lift/lower, travel, and horn—accessible from either side of the handle for left- or right-handed operators.



Battery Discharge Indicator with lift interrupt prevents over-discharging of the battery to protect electrical components.

FEATURES

- » 3,500 lb. Capacity
- » Speed Control
- » Lift/Lower Cut Out
- » On-Board Charger
- » Low Maintenance Battery Pack
- » AC Motor
- » Smooth Pallet Entry and Exit

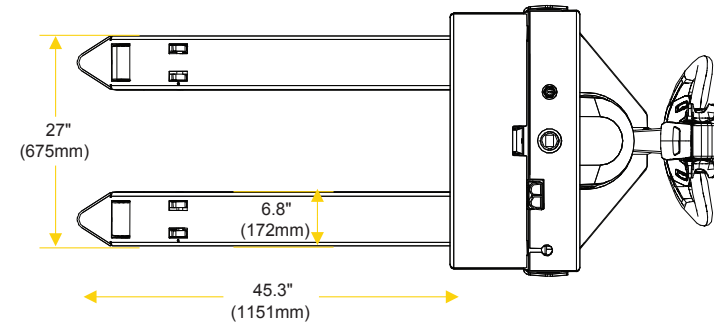
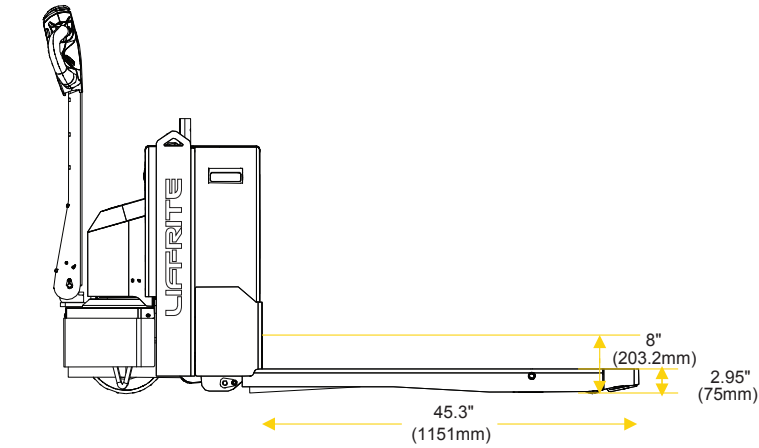
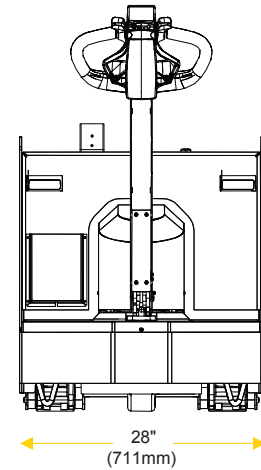

PRODUCT SPECIFICATIONS

CAPACITY	3,500 lbs.
FORK OVERALL WIDTH (OAW):	27 inches
FORK LENGTH (NOMINAL):	48 inches
LOW HEIGHT:	2.95 inches
RAISED HEIGHT:	8 inches
DRIVE TIRE:	9.8 inches
LOAD WHEEL:	3 inches
TRAVEL SPEED (FL/NL):	3.4 mph
WEIGHT:	715 lbs.
WEIGHT:	1005 lbs. (with battery)

LIFTRITE

KEEPS YOU MOVING

PO Box 130, Greene, NY 13778-0130
www.liftright.com | Toll free 1-800-558-6012

Due to continuous product improvement, specifications are subject to change without notice or obligation.
Some systems and features shown are optional at extra cost. Lift-Rite is a U.S. trademark of Lift-Rite.

©2017 Lift-Rite
Printed in USA SIPB-1060 717