



LAGER- und TRANSPORTBEHÄLTER

STORAGE and TRANSPORT CONTAINERS



TRADITION

Seit 1949 ein Familienunternehmen in 3. Generation mit Stammsitz in Altenkirchen, Deutschland

HISTORY

A family owned company in the 3rd generation since 1949, with its headquarters in Altenkirchen, Germany

KERNKOMPETENZEN

in der Kunststoffverarbeitung für die:

Verpackungsindustrie

- IBC
- Industrietanks
- Lager- und Transportbehälter
- Kunststoffpaletten
- Kanister

Haustechnik:

- Heizöltanks
- Elektroinstallationsmaterial
- Sanitärprodukte

CORE COMPETENCIES

in the processing of plastics for the:

Packaging industry:

- IBC
- Industrial Tanks
- Storage- and Transport Containers
- Plastic Pallets
- Canisters

Domestic Engineering:

- Heating Oil Tanks
- Electrical Installation Materials
- Plumbing Products

STABILITÄT

Seit Jahrzehnten wächst die WERIT-Unternehmensgruppe generisch ohne finanzielle Mittel von Banken. Mit Perspektive auf die bereitstehende 4. Generation, ist die Strategie klar auf kontinuierliches Wachstum in Europa ausgerichtet.

STABILITY

The WERIT Group has been growing generically without any financial resources from banks for decades. With the perspective on the forthcoming 4th generation, the strategy is clearly directed to a continuous growth throughout Europe.

KUNDENORIENTIERUNG

Flexible, auftragsbezogene Fertigung – hohe Reaktionsfähigkeit und Servicebereitschaft bis zur kundenspezifischen Lösung.

CUSTOMER FOCUS

Tailor-made and order-related manufacturing – high responsiveness and service availability to the customer specific solution.

GB-Manchester

F-Montélimar

E-Granollers/Barcelona

NACHHALTIGKEIT

leben wir bei WERIT über:

- den verantwortungsvollen Umgang mit Ressourcen
- ein zertifiziertes Energiemanagement
- ein effizientes Rohstoffmanagement
- und eine konkrete Recyclingstrategie, unter anderem mit dem IBC Rücknahmesystem – PACKONE.

SUSTAINABILITY

is acted out by WERIT in:

- a responsible resource management
- a certified energy management
- an efficient management of raw materials
- and a precise recycling strategy, amongst other things the IBC return ticket – PACKONE.

STANDORTE

WERIT beschäftigt mehr als 600 Mitarbeiter (m/w) an sechs Fertigungs- und vier Vertriebsstandorten.

SUBSIDIARIES

WERIT employs more than 600 employees in six production sites and four distribution sites.

D-Ottendorf-Okrilla

PL-Wrocław

A-Bludenz

STRATEGIE

Anbieter kundenspezifischer Lösungen und innovativer Produkte mit Fokus auf Wachstum und Expansion im Kernmarkt Europa.

STRATEGY

Supplier of customer specific solutions and innovative products with focus on growth and expansion in the core market of Europe.

EXPERTISE

WERIT ist seit 1949 Innovationstreiber im Bereich der Kunststoffverarbeitung, insbesondere der Spritzgüßfertigung. Mit einer eigenen Entwicklung, einem eigenen Werkzeugbau und dem daraus gewachsenem Know-how stehen WERIT Lager- und Transportbehälter für Qualität und Funktionalität.

EXPERTISE

WERIT has been a driver of innovations in the field of plastics processing, particularly in the injection moulding manufacturing since 1949. With their own development, their own tool design and construction and the resulting know-how, WERIT's Transport and Storage Containers represent quality and functionality.



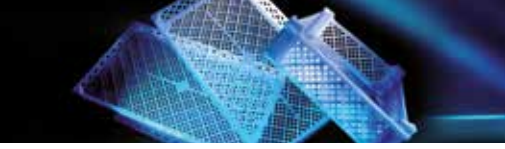
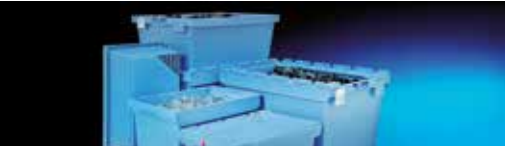
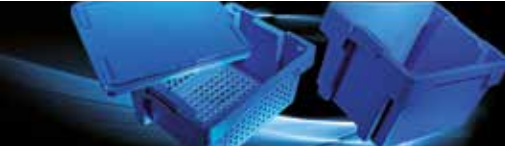
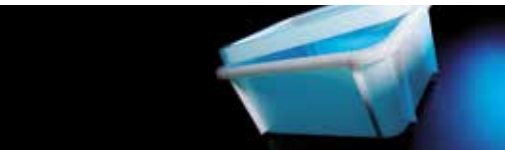
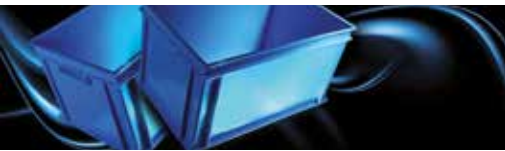

	Größe Size	Seiten Pages
<p>■ Euronorm Stapelkästen (Versionen: Standardausführung, ESD, Sonderausführung) Eurostandard stacking crates (Versions: Standard, ESD, special Design)</p>	<p>400 x 300 mm 600 x 400 mm</p>	<p>7-14</p>
<p>■ Stapelkästen mit U-Rand Stacking crates with curved lips</p>	<p>400 x 300 mm 600 x 400 mm 800 x 600 mm</p>	<p>15-17</p>
<p>■ Fleischkästen Meat crates</p>	<p>400 x 300 mm 600 x 400 mm</p>	<p>19-21</p>
<p>■ Rollwagen Roller trucks</p>	<p>600 x 400 mm 800 x 600 mm</p>	<p>23-25</p>
<p>■ Drehstapelbehälter (Versionen: DSBN, Twistbox, mit U-Rand) Rotary stacking containers (Versions: DSBN, Twistbox, with curved lips)</p>	<p>400 x 300 mm 600 x 400 mm 800 x 600 mm</p>	<p>27-35</p>
<p>■ Mehrwegbehälter Multiway containers</p>	<p>300 x 200 mm 400 x 300 mm 600 x 400 mm 800 x 400 mm</p>	<p>37-39</p>
<p>■ Becken und Kästen Tubs and boxes</p>	<p>Sonderabmessungen special dimensions</p>	<p>41-43</p>
<p>■ Stapelkästen und Schalen Stacking crates and trays</p>	<p>Sonderabmessungen special dimensions</p>	<p>45-47</p>
<p>■ Rundbehälter, Tonnen und Eimer Round containers, barrels and buckets</p>	<p>verschiedene Ø special Ø</p>	<p>49-51</p>
<p>■ Warenkörbe Baskets</p>	<p>575 x 375 mm 710 x 400 mm</p>	<p>53-55</p>
<p>■ Großbehälter Large containers</p>	<p>140 - 650 l</p>	<p>57-59</p>
<p>■ Spezifische Lösungen und Identifikation Custom-designed solutions and identification</p>		<p>61-65</p>
<p>■ Anhang Annex Chemische Beständigkeit, Notizen, Legende / ausklappbar Chemical resistance, notes, caption / fold out</p>		<p>66-69</p>



EURONORM-STAPELKÄSTEN

Eurostandard stacking crates

400 x 300 mm
600 x 400 mm
ESD



WERIT Stapelkästen sind geeignet für den Einsatz in: Industrie, Handel und Lebensmittelindustrie. Alle WERIT Euronorm-behälter entsprechen dem Europalettenmaß und sparen somit Transportkosten und Lagervolumen. Auf Anfrage realisieren wir gerne kundenspezifische Lösungen. Nähere Informationen dazu siehe Seite 61-65.

WERIT crates are suitable for: industrial use, commercial use and food industry. All WERIT Eurostandard stacking crates comply with the Europallet dimensions and as a consequence of this they save transport costs and storage volume. On request we gladly realize your special solutions. For more information, please look at page 61-65.

252-32843000



252-32821000



252-32831000



252-32841000



252-32513N00



252-32523N00



252-32533N00



252-32513N01



252-32523N01



252-32533N01



Griffauswahl / Handle choice
ab 500 Stk / from pcs up



Deckel / Lid



Etikettenhalter
Label holder



Identifikation
Identification



Transportroller
Roller truck



Beschriftung
Marking

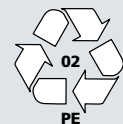

ab 300 Stk
from 300 pcs. up

Standardfarbe / Standard Colour:

- mattweiß, matt-white
- grau, grey
- blau, blue
- rot, red

Material: HDPE

Temp.°C: -30°C bis/to +60°C

Ausnahme / Exception:

252-3248..., -3249..., - 3295..., 3271....:

Material: PP (Polypropylen)

Temp.°C: -20°C bis/to +90°C

Gitterboden / Perforated bottom: 15 x 15 mm

Gitterseite / Perforated sides: 20 x 20 mm

Version:

A: Boden und Seiten geschlossen /
Solid bottom and sides

B: Boden und Seiten durchbrochen /
Perforated bottom and sides

C: Boden geschlossen, Seiten durchbrochen /
Solid bottom, perforated sides

1: Griffleiste / Handle grip

2: 2 Grifföffnungen / 2 Handle openings

3: 4 Grifföffnungen / 4 Handle openings

* Scharnierdeckel nicht für 252-3254...3259...3264 geeignet.

* Hinged lid not suitable for 252-3254...3259...3264.

* Mindestabnahmemenge 500 Stk

* Minimum purchase quantity 500 pcs

Artikel Nr. Article No.	Farbe Colour	Außen (mm) External (mm) (A x D x E)	Innen (mm) Internal (mm) (B x C x F)	Volumen Volume (L)	Gewicht Weight (kg)	Version	Palette Pallet (Stk/pcs)
<i>Boden und Seiten geschlossen, Griffleiste oder 2 Grifföffnungen / Solid bottom and sides, handle grip or 2 handle openings</i>							
252-32801000	□	400 x 300 x 120	368 x 269 x 116	11	1,0	A, 1	128
252-32803000	■	400 x 300 x 120	368 x 269 x 116	11	1,0	A, 1	128
252-32811000	□	400 x 300 x 170	368 x 269 x 166	16	1,2	A, 1	96
252-32813000	■	400 x 300 x 170	368 x 269 x 166	16	1,2	A, 1	96
252-32821000	□	400 x 300 x 220	368 x 269 x 216	21	1,4	A, 1	72
252-32823000	■	400 x 300 x 220	368 x 269 x 216	21	1,4	A, 1	72
252-32831000	□	400 x 300 x 270	368 x 269 x 266	26	1,6	A, 1	56
252-32833000	■	400 x 300 x 270	368 x 269 x 266	26	1,6	A, 1	56
252-32841000	□	400 x 300 x 320	368 x 269 x 316	31	1,9	A, 1	48
252-32843000	■	400 x 300 x 320	368 x 269 x 316	31	1,9	A, 1	48
252-32843VGÖ	■	400 x 300 x 320	368 x 269 x 316	31	1,9	A, 2	48
252-32481000	□	600 x 400 x 50	565 x 365 x 46	9	1,2	A, 1	160
252-32483000	■	600 x 400 x 50	565 x 365 x 46	9	1,2	A, 1	160
252-32491000	□	600 x 400 x 75	565 x 365 x 71	14	1,3	A, 1	108
252-32493000	■	600 x 400 x 75	565 x 365 x 71	14	1,3	A, 1	108
252-32501N00	□	600 x 400 x 120	569 x 369 x 116	23	1,5	A, 1	72
252-32503N00	■	600 x 400 x 120	569 x 369 x 116	23	1,5	A, 1	72
252-32504N00	■	600 x 400 x 120	569 x 369 x 116	23	1,5	A, 1	72
252-32507N00	■	600 x 400 x 120	569 x 369 x 116	23	1,5	A, 1	72
252-32511N00	□	600 x 400 x 170	569 x 369 x 166	34	1,8	A, 1	48
252-32511N01	□	600 x 400 x 170	569 x 369 x 166	34	1,8	A, 2	48
252-32513N00	■	600 x 400 x 170	569 x 369 x 166	34	1,8	A, 1	48
252-32513N01	■	600 x 400 x 170	569 x 369 x 166	34	1,8	A, 2	48
252-32514N00	■	600 x 400 x 170	569 x 369 x 166	34	1,8	A, 1	48
252-32514N01	■	600 x 400 x 170	569 x 369 x 166	34	1,8	A, 2	48
252-32517N00	■	600 x 400 x 170	569 x 369 x 166	34	1,8	A, 1	48
252-32517N01	■	600 x 400 x 170	569 x 369 x 166	34	1,8	A, 2	48
252-32521N00	□	600 x 400 x 220	569 x 369 x 216	44	2,2	A, 1	36
252-32521N01	□	600 x 400 x 220	569 x 369 x 216	44	2,2	A, 2	36
252-32523N00	■	600 x 400 x 220	569 x 369 x 216	44	2,2	A, 1	36
252-32523N01	■	600 x 400 x 220	569 x 369 x 216	44	2,2	A, 2	36
252-32524N00	■	600 x 400 x 220	569 x 369 x 216	44	2,2	A, 1	36
252-32524N01	■	600 x 400 x 220	569 x 369 x 216	44	2,2	A, 2	36
252-32527N00	■	600 x 400 x 220	569 x 369 x 216	44	2,2	A, 1	36
252-32527N01	■	600 x 400 x 220	569 x 369 x 216	44	2,2	A, 2	36
252-32531N00	□	600 x 400 x 320	569 x 369 x 316	64	2,9	A, 1	24
252-32531N01	□	600 x 400 x 320	569 x 369 x 316	64	2,9	A, 2	24
252-32533N00	■	600 x 400 x 320	569 x 369 x 316	64	2,9	A, 1	24
252-32533N01	■	600 x 400 x 320	569 x 369 x 316	64	2,9	A, 2	24
252-32534N00	■	600 x 400 x 320	569 x 369 x 316	64	2,9	A, 1	24
252-32534N01	■	600 x 400 x 320	569 x 369 x 316	64	2,9	A, 2	24
252-32537N00	■	600 x 400 x 320	569 x 369 x 316	64	2,9	A, 1	24
252-32537N01	■	600 x 400 x 320	569 x 369 x 316	64	2,9	A, 2	24
252-32541000*	□	600 x 400 x 420	565 x 365 x 416	83	3,9	A, 2	20
252-32543000*	■	600 x 400 x 420	565 x 365 x 416	83	3,9	A, 2	20
252-32544000*	■	600 x 400 x 420	565 x 365 x 416	83	3,9	A, 2	20
252-32547000*	■	600 x 400 x 420	565 x 365 x 416	83	3,9	A, 2	20

252-32583000 ■



252-32453000 ■



252-32871000 □

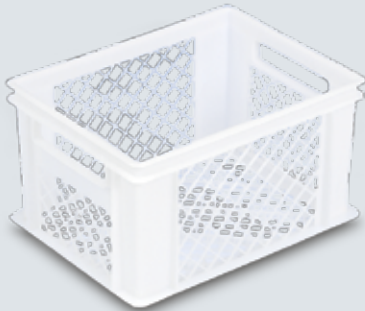

252-32921000 □



252-32703000 ■



252-32713000 ■



252-32713S00 ■



Griffauswahl / Handle choice
ab 500 Stk / from pcs up



Deckel / Lid



Etikettenhalter
Label holder



Identifikation
Identification



Transportroller
Roller truck



Beschriftung
Marking



PE



ab 300 Stk
from 300 pcs. up

Zubehör / Accessories

269-39900000

269-39910000

269-39990000

269-3998K000

269-3998L000

Scharnierverschluss für Aufgedeckel / Hinge lock for Flat lid

Schiebeverschluss für Scharnierdeckel / Slide Closure for Hinged lid

Schnappverschluss für Scharnierdeckel / Snap lock for Hinged lid

Etikettenhalter, kurz / Label holder, short

Etikettenhalter, lang / Label holder, long

* Scharnierdeckel nicht für 252-3254...3259...3264 geeignet.

* Hinged lid not suitable for 252-3254...3259...3264.

* Mindestabnahmemenge 500 Stk

* Minimum purchase quantity 500 pcs

Artikel Nr. Article No.	Farbe Colour	Außen (mm) External (mm) (A x D x E)	Innen (mm) Internal (mm) (B x C x F)	Volumen Volume (L)	Gewicht Weight (kg)	Version	Palette Pallet (Stk/pcs)
<i>Boden und Seiten durchbrochen, 4 Grifföffnungen / Perforated bottom and sides, 4 handle openings</i>							
252-32851000	□	400 x 300 x 126	368 x 269 x 116	11	0,8	B, 2	128
252-32853000	■	400 x 300 x 126	368 x 269 x 116	11	0,8	B, 2	128
252-32861000	□	400 x 300 x 176	368 x 269 x 166	16	0,9	B, 2	96
252-32863000	■	400 x 300 x 176	368 x 269 x 166	16	0,9	B, 2	96
252-32871000	□	400 x 300 x 226	368 x 269 x 216	21	1,0	B, 2	72
252-32873000	■	400 x 300 x 226	368 x 269 x 216	21	1,0	B, 2	72
252-32551000	□	600 x 400 x 120	565 x 365 x 116	23	1,2	B, 3	72
252-32553000	■	600 x 400 x 120	565 x 365 x 116	23	1,2	B, 3	72
252-32421000	□	600 x 400 x 150	565 x 365 x 146	29	1,3	B, 3	56
252-32423000	■	600 x 400 x 150	565 x 365 x 146	29	1,3	B, 3	56
252-32561000	□	600 x 400 x 170	565 x 365 x 166	33	1,4	B, 3	48
252-32563000	■	600 x 400 x 170	565 x 365 x 166	33	1,4	B, 3	48
252-32571000	□	600 x 400 x 220	565 x 365 x 216	43	1,7	B, 3	36
252-32573000	■	600 x 400 x 220	565 x 365 x 216	43	1,7	B, 3	36
* 252-32581000	□	600 x 400 x 320	565 x 365 x 316	63	2,0	B, 3	24
252-32583000	■	600 x 400 x 320	565 x 365 x 316	63	2,0	B, 3	24
252-32431000	□	600 x 400 x 350	565 x 365 x 346	69	2,1	B, 3	24
252-32433000	■	600 x 400 x 350	565 x 365 x 346	69	2,1	B, 3	24
252-32591000*	□	600 x 400 x 426	565 x 365 x 416	83	2,4	B, 3	20
252-32593000*	■	600 x 400 x 426	565 x 365 x 416	83	2,4	B, 3	20
<i>Boden geschlossen, Seiten durchbrochen, 4 Grifföffnungen / Solid bottom, perforated sides, 4 handle openings</i>							
252-32901000	□	400 x 300 x 120	368 x 269 x 116	11	0,9	C, 2	128
252-32903000	■	400 x 300 x 120	368 x 269 x 116	11	0,9	C, 2	128
252-32911000	□	400 x 300 x 170	368 x 269 x 166	16	1,0	C, 2	96
252-32913000	■	400 x 300 x 170	368 x 269 x 166	16	1,0	C, 2	96
252-32921000	□	400 x 300 x 220	368 x 269 x 216	21	1,1	C, 2	72
252-32923000	■	400 x 300 x 220	368 x 269 x 216	21			
* 252-32601000	□	600 x 400 x 120	565 x 365 x 116	23	1,5	C, 3	72
252-32603000	■	600 x 400 x 120	565 x 365 x 116	23	1,5	C, 3	72
* 252-32441000	□	600 x 400 x 150	565 x 365 x 146	29	1,6	C, 3	56
* 252-32443000	■	600 x 400 x 150	565 x 365 x 146	29	1,6	C, 3	56
* 252-32611000	□	600 x 400 x 170	565 x 365 x 166	33	1,7	C, 3	48
252-32613000	■	600 x 400 x 170	565 x 365 x 166	33	1,7	C, 3	48
* 252-32621000	□	600 x 400 x 220	565 x 365 x 216	43	2,0	C, 3	36
252-32623000	■	600 x 400 x 220	565 x 365 x 216	43	2,0	C, 3	36
* 252-32631000	□	600 x 400 x 320	565 x 365 x 316	63	2,3	C, 3	24
252-32633000	■	600 x 400 x 320	565 x 365 x 316	63	2,3	C, 3	24
* 252-32451000	□	600 x 400 x 350	565 x 365 x 346	69	2,4	C, 3	24
* 252-32453000	■	600 x 400 x 350	565 x 365 x 346	69	2,4	C, 3	24
* 252-32641000*	□	600 x 400 x 420	565 x 365 x 416	83	2,7	C, 3	20
252-32643000*	■	600 x 400 x 420	565 x 365 x 416	83	2,7	C, 3	20
<i>Deckel / Lids (mm)</i>					(kg)	<i>(Karton / Carton)</i>	
252-32951000	□	400 x 300	Auflagedeckel / Flat lid		0,45		90
252-32953000	■	400 x 300	Auflagedeckel / Flat lid		0,45		90
252-32951500	□	400 x 300	Scharnierdeckel / Hinged lid		0,45		90
252-32953500	■	400 x 300	Scharnierdeckel / Hinged lid		0,45		90
252-32701000	□	600 x 400	Stülpdeckel / Hooded lid		0,9		18
252-32703000	■	600 x 400	Stülpdeckel / Hooded lid		0,9		18
252-32704000	■	600 x 400	Stülpdeckel / Hooded lid		0,9		18
252-32707000	■	600 x 400	Stülpdeckel / Hooded lid		0,9		18
252-32711000	□	600 x 400	Auflagedeckel / Flat lid		0,9		50
252-32713000	■	600 x 400	Auflagedeckel / Flat lid		0,9		50
252-32714000	■	600 x 400	Auflagedeckel / Flat lid		0,9		50
252-32717000	■	600 x 400	Auflagedeckel / Flat lid		0,9		50
252-32711500*	□	600 x 400	Scharnierdeckel / Hinged lid		0,9		50
252-32713500*	■	600 x 400	Scharnierdeckel / Hinged lid		0,9		50
252-32714500*	■	600 x 400	Scharnierdeckel / Hinged lid		0,9		50
252-32717500*	■	600 x 400	Scharnierdeckel / Hinged lid		0,9		50

252-3284NESD ■



252-3251NESD ■



252-3252NESD ■



252-3253NESD ■



Griffauswahl / Handle choice
ab 500 Stk / from pcs up



Deckel / Lid



Identifikation
Identification



Transportroller
Roller truck



Beschriftung
Marking



Die WERIT Euronorm Stapelkästen ESD, aus elektrisch leitfähigem Kunststoff, wurden speziell für den sicheren Transport und die Lagerung von elektronischen Bauelementen entwickelt. Konstruktion und Material verhindern eine mögliche elektrostatische Entladung. Die optimale Bauform der Kunststoffbehälter schützt den Inhalt vor Beschädigung, Verschmutzung und Feuchtigkeit.

The WERIT Eurostandard stacking crates ESD, made of electrically conductive plastic, are especially developed for the safe transport and storing of electronic components. Design and material prevent possible static charging. The best possible type of construction protects the content of our plastic stacking crates against damage, contamination and moisture.

Standardfarbe / Standard Colour:

■ schwarz / black

Material: PP EL

Temp.°C: -20°C bis / to +80°C

Oberflächenwiderstand / surface resistance:
10⁴-10⁶

A: Boden und Seiten geschlossen
Solid bottom and sides

1: Griffleiste / Handle grip

Artikel Nr. Article No.	Farbe Colour	Außen (mm) External (mm) (A x D x E)	Innen (mm) Internal (mm) (B x C x F)	Volumen Volume (L)	Gewicht Weight (kg)	Version	Palette Pallet (Stk/pcs)
<i>Boden und Seiten geschlossen, Griffleiste, 2 Grifföffnungen / Solid bottom and sides, handle grip, 2 handle openings</i>							
252-3280ESD0	■	400 x 300 x 120 mm		11		A, 1	128
252-3281ESD0	■	400 x 300 x 170 mm		16		A, 1	96
252-3282ESD0	■	400 x 300 x 220 mm		21		A, 1	72
252-3283ESD0	■	400 x 300 x 270 mm		26		A, 1	56
252-3284ESD0	■	400 x 300 x 320 mm		31		A, 1	48
252-3250NESD	■	600 x 400 x 120 mm				A, 1	72
252-3251NESD	■	600 x 400 x 170 mm				A, 1	56
252-3252NESD	■	600 x 400 x 220 mm				A, 1	36
252-3253NESD	■	600 x 400 x 320 mm				A, 1	24
<i>Deckel, Zubehör / Lids, Accessories</i>		<i>(mm)</i>					
252-3295ESD0	■	400 x 300 mm					90
252-3295SESD	■	400 x 300 mm					90
252-3270ESD0	■	600 x 400 mm					18
252-3271ESD0	■	600 x 400 mm					50
252-3271SESD	■	600 x 400 mm					50
269-39900000*						<i>Scharnierverschluss für Auflagendeckel / Hinge lock for Flat lid</i>	
269-39910000*						<i>Schiebeverschluss für Scharnierdeckel / Slide Closure for Hinged lid</i>	
269-39990000*						<i>Schnappverschluss für Scharnierdeckel / Snap lock for Hinged lid</i>	

* Verschlüsse in Weiß, nicht leitfähig

* Closures in white, not conductive

Bei konisch geformten Behältern weicht das Innenmaß unten von dem oben ab. Gegebenenfalls kann vorab ein Musterbehälter getestet werden. Bei allen Daten und Maßen sind Toleranzen möglich!

The inside dimension from cone-shaped containers differs between the top and the bottom. If necessary a sample container can be pre-tested. Tolerances are possible at all stated data and measures!

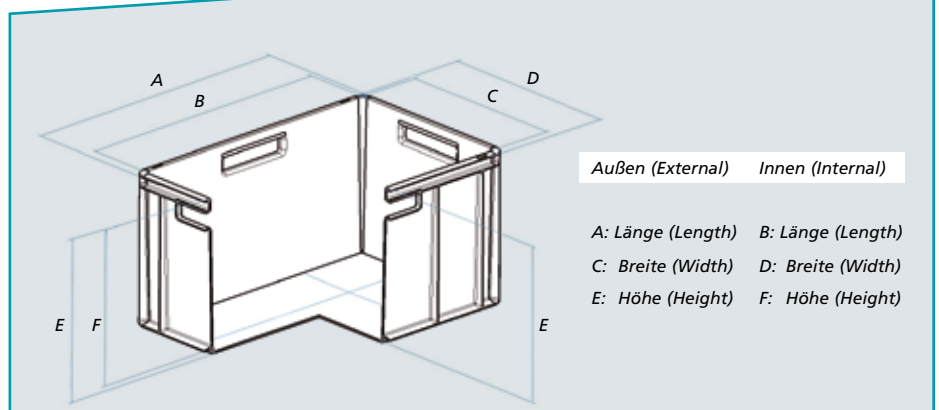

Euronorm Stapelkästen Eurostandard stacking crates

Sonderausführungen special designs

WERIT Euronorm Stapelkästen erhalten Sie mit einem Rippenboden für den Einsatz auf Förderanlagen und bei einer automatisierten Lagerhaltung. Eine hohe Inhaltsbelastung bis zu 50 kg ist in dieser Produktausführung kein Problem.

Auf Anfrage realisieren wir gerne kundenspezifische Lösungen, sprechen Sie uns an!

Unsere Sonderausführungen sind alle mit den Standard Euronorm Stapelkästen kompatibel.

You get WERIT Euronorm crates with a rib ground for use on conveyors and at an automated storekeeping. Heavy loads up to 50 kgs are no problem in this product execution.

On request we are gladly ready to realize your specific solutions. Please contact us!

Our custom-built models are all compatible with the basic Eurostandard stacking crates.

Farbe / Colour:

nach Ihrer Wahl
your choice



Material: HDPE

Temp.:°C: -30°C bis/to +60°C

Mindestabnahmemenge: 500 Stk

Minimum purchase quantity: 500 pcs

A: Boden und Seiten geschlossen
Solid bottom and sides

2: 2 Grifföffnungen / 2 Handle openings

4: Rippenboden / Ribbed bottom

5: Angespritzter Etikettenhalter
Moulded-on label holder



Ein Euronorm Stapelkasten mit Rippenboden und Maschinenprägung.

A Euronorm crate with a rib ground and machine stamping.

Artikel Nr. Article No.	Farbe Colour	Außen (mm) External (mm) (A x D x E)	Innen (mm) Internal (mm) (B x C x F)	Volumen Volume (L)	Gewicht Weight (kg)	Version	Palette Pallet (Stk/pcs)
<i>Boden und Seiten geschlossen, 2 Grifföffnungen, Rippenboden / Solid bottom and sides, 2 handle openings, ribbed bottom</i>							
252-3250R00	<input type="checkbox"/>	600 x 400 x 120	567 x 367 x 100	20	2,3	A, 2, 4	72
252-32510R00	<input type="checkbox"/>	600 x 400 x 170	567 x 367 x 150	30	2,6	A, 2, 4	48
252-32520R00	<input type="checkbox"/>	600 x 400 x 220	567 x 367 x 200	40	2,9	A, 2, 4	36
252-32530R00	<input type="checkbox"/>	600 x 400 x 320	567 x 367 x 300	60	3,6	A, 2, 4	24
252-32540R00*	<input type="checkbox"/>	600 x 400 x 420	567 x 367 x 400	80	4,4	A, 2, 4	20
<i>Boden und Seiten geschlossen, 2 Grifföffnungen, Angespritzter Etikettenhalter / Solid bottom and sides, 2 handle openings, moulded-on label holder</i>							
252-32660000	<input type="checkbox"/>	600 x 400 x 170	567 x 367 x 160	33	2,1	A, 2, 5	48
252-32670000	<input type="checkbox"/>	600 x 400 x 220	567 x 367 x 216	43	2,4	A, 2, 5	36
252-32680000	<input type="checkbox"/>	600 x 400 x 320	567 x 367 x 316	63	3,1	A, 2, 5	24

* Scharnierdeckel nicht für 252-32540R... geeignet.

* Hinged lid not suitable for 252-32540R...

* Etikettenfeld 210 x 85 mm / Label field 210 x 85 mm



Griffauswahl / Handle choice
ab 500 Stk / from pcs up



Deckel / Lid



Etikettenhalter
Label holder



Identifikation
Identification



Transportroller
Roller truck



Beschriftung
Marking

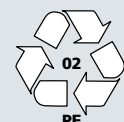

ab 500 Stk
from 500 pcs. up



U-RAND STAPELKÄSTEN

Stacking crates with curved lips

400 x 300 mm
600 x 400 mm
800 x 600 mm

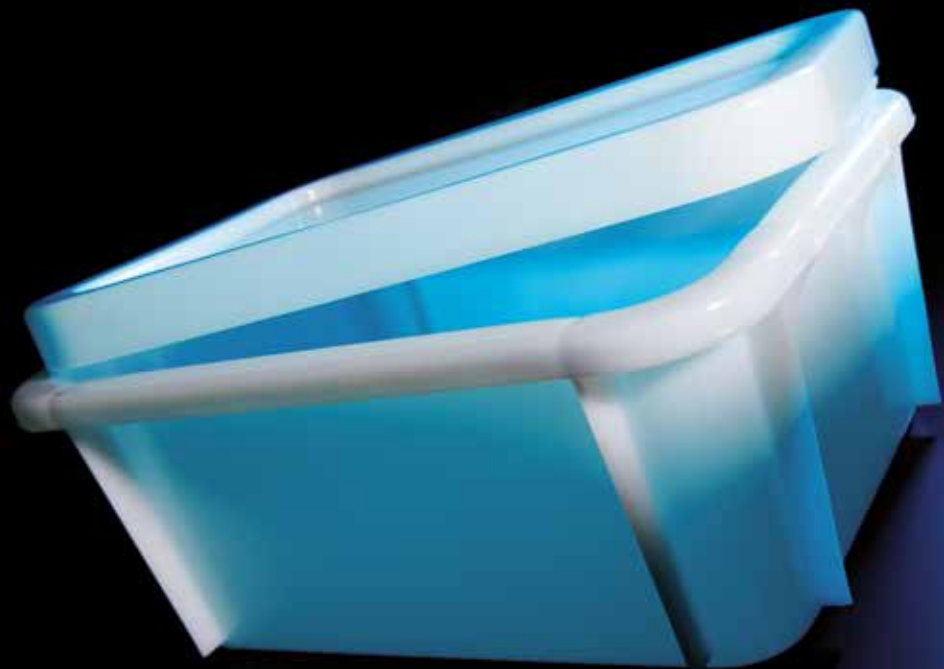

256-31111000



256-31551000



256-31561000



256-31571000 256-31621000



256-31581000



256-31591000



256-31633000



256-31601000



Deckel / Lid



Etikettenhalter
Label holder



Identifikation
Identification

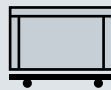

Transportroller
Roller truck



Beschriftung
Marking

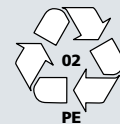

ab 300 Stk
from 300 pcs. up

Die Perfektionisten für die Lebensmittelindustrie und überall dort, wo Hygiene und schnelle Reinigung eine entscheidende Größe darstellen! Aufgrund der runden Behältergeometrie entstehen klare Vorteile. Die Behälter lassen sich einfach reinigen, haben keine Schmutzecken und einen guten Tragekomfort. Dadurch sparen Sie Zeit und Kosten in Ihrem Unternehmen!

The perfectionists for food-industries and wherever hygiene and fast cleaning are most important! Due to the round geometry this crate system offers deciding advantages like a simple and fast cleaning, no dirt-corners and a good carrying comfort. These advantages guarantee time saving and as a consequence of this reduce expenses in your company!

Standardfarbe / Standard Colour:

- mattweiß, matt-white
- grau, grey

Material: HDPE

Temp. °C: -30°C bis/to +60°C

Version:

- A: Boden und Seiten geschlossen
Solid bottom and sides
- 6: Mit Wasserablaulöchern im U-Rand
With drainage holes in curved lips

Artikel Nr. Article No.	Farbe Colour	Außen (mm) External (mm) (A x D x E)	Innen (mm) Internal (mm) (B x C x F)	Volumen Volume (L)	Gewicht Weight (kg)	Version	Palette Pallet (Stk/pcs)
<i>Boden und Seiten geschlossen / Solid bottom and sides</i>							
256-31551000	<input type="checkbox"/>	400 x 300 x 165	342 x 244 x 162	13	1,0	A	112
256-31553000	<input type="checkbox"/>	400 x 300 x 165	342 x 244 x 162	13	1,0	A	112
256-31561000	<input type="checkbox"/>	400 x 300 x 215	342 x 244 x 212	18	1,2	A	72
256-31563000	<input type="checkbox"/>	400 x 300 x 215	342 x 244 x 212	18	1,2	A	72
<i>Boden und Seiten geschlossen mit Wasserablaulöchern im U-Rand / Solid bottom and sides with drainage holes in curved lips</i>							
256-31571000	<input type="checkbox"/>	600 x 400 x 165	540 x 345 x 162	30	1,5	A, 6	48
256-31573000	<input type="checkbox"/>	600 x 400 x 165	540 x 345 x 162	30	1,5	A, 6	48
256-31581000	<input type="checkbox"/>	600 x 400 x 215	540 x 345 x 213	40	1,8	A, 6	36
256-31583000	<input type="checkbox"/>	600 x 400 x 215	540 x 345 x 213	40	1,8	A, 6	36
256-31591000	<input type="checkbox"/>	600 x 400 x 320	540 x 345 x 318	60	2,4	A, 6	24
256-31593000	<input type="checkbox"/>	600 x 400 x 320	540 x 345 x 318	60	2,4	A, 6	24
<i>Boden und Seiten geschlossen / Solid bottom and sides</i>							
256-31631000	<input type="checkbox"/>	800 x 600 x 220	740 x 540 x 215	80	3,5	A	18
256-31633000	<input type="checkbox"/>	800 x 600 x 220	740 x 540 x 215	80	3,5	A	18
256-31601000	<input type="checkbox"/>	800 x 600 x 320	740 x 540 x 315	120	4,3	A	12
256-31603000	<input type="checkbox"/>	800 x 600 x 320	740 x 540 x 315	120	4,3	A	12
<i>Deckel / Lids</i>		<i>(mm)</i>		<i>(kg)</i>		<i>(Karton / Carton)</i>	
256-31111000	<input type="checkbox"/>	400 x 300	Stülpdeckel / Hooded lid	0,50			32
256-31113000	<input type="checkbox"/>	400 x 300	Stülpdeckel / Hooded lid	0,50			32
256-31621000	<input type="checkbox"/>	600 x 400	Stülpdeckel / Hooded lid	0,95			15
256-31623000	<input type="checkbox"/>	600 x 400	Stülpdeckel / Hooded lid	0,95			15



Bei konisch geformten Behältern, weicht das Innenmaß unten von dem oben ab. Gegebenenfalls kann vorab ein Musterbehälter getestet werden. Bei allen Daten und Maßen sind Toleranzen möglich!

The inside dimension from cone-shaped containers differs between the top and the bottom. If necessary a sample container can be pre-tested. Tolerances are possible at all stated data and measures!

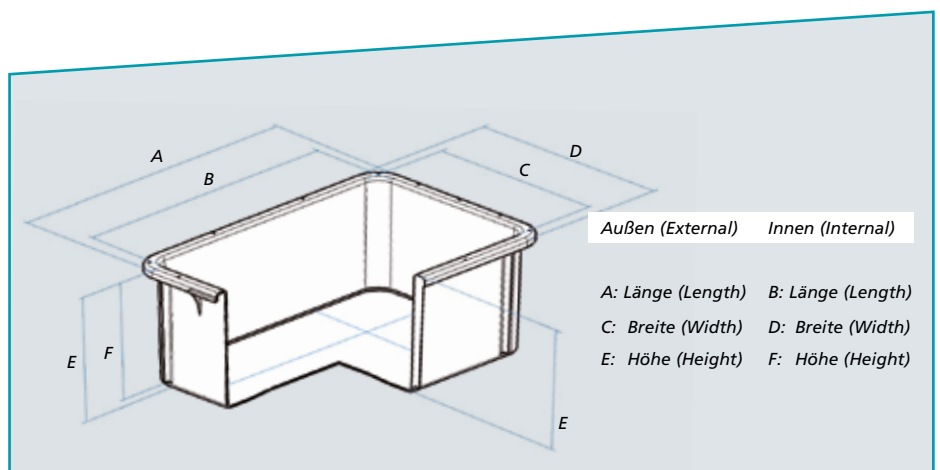



FLEISCHKÄSTEN

Meat crates

400 x 300 mm
600 x 400 mm



261-34504000



252-32714100



261-34511000



261-34513000



261-34514000



261-34515000



261-34516000



261-34517000



261-34524000



261-34527000



261-34534000

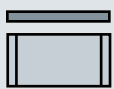

Deckel / Lid



Etikettenhalter
Label holder



Identifikation
Identification

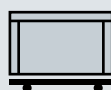

Transportroller
Roller truck



Beschriftung
Marking

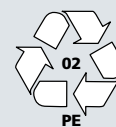

ab versch. Stk-Zahlen
up to different pcs.

WERIT Fleischkästen sind standardisierte Transportmittel der fleisch- und wurstverarbeitenden Industrie und des Handels und entsprechen dem Anforderungsprofil des EHI sowie der DIN 55 423. Durch den glatten Boden sind die Kästen für den Einsatz auf Rollenbahnen und Transportbändern geeignet. Die Löcher und Grifföffnungen gewährleisten eine gute Luftzirkulation. Der umlaufende Rand ist selbstzentrierend und -verriegelnd und garantiert, dass Wasser nach außen abläuft.

WERIT meat crates are standardized means of transport for the meat- and sausage processing industries and for the trade and correspond with the requirement profiles of the EHI and DIN 55 423. Because of their smooth bottoms the boxes are suitable for use on roller tracks and conveyor belts. The holes and handle openings ensure good air circulation. The circumferential edge is self-centring and self-interlocking and guarantees that water runs out.

Standardfarbe / Standard Colour:

 rot / red RAL 2002
weitere Farben auf Anfrage
further colours on request

Material: HDPE

Temp.°C: -30°C bis/to +60°C

Ausnahme / Exception:

252-32714100











PP (Polypropylen)

Temp.°C: -20°C bis/to +90°C

Version:

Fleischkästen / Meat crates:

E1, E2, E3 und E4

Artikel Nr. Article No.	Farbe Colour	Außen (mm) External (mm)	Volumen Volume (L)	Gewicht Weight (kg)	Version	Palette Pallet (Stk/pcs)
<i>Fleischkästen / Meat crates: E1</i>						
261-34504000		600 x 400 x 125	25	1,5	E1	60
<i>Fleischkästen / Meat crates: E2</i>						
261-34511000		600 x 400 x 200	40	2,0	E2	40
261-34513000		600 x 400 x 200	40	2,0	E2	40
261-34514000		600 x 400 x 200	40	2,0	E2	40
261-34515000		600 x 400 x 200	40	2,0	E2	40
261-34516000		600 x 400 x 200	40	2,0	E2	40
261-34517000		600 x 400 x 200	40	2,0	E2	40
<i>Fleischkästen / Meat crates: E3</i>						
261-34524000		600 x 400 x 300	60	3,0	E3	28
261-34527000		600 x 400 x 300	60	3,0	E3	28
<i>Fleischkästen / Meat crates: E4</i>						
261-34534000		400 x 300 x 125	11,6	0,75	E4	120
<i>Deckel / Lids</i>						
	(mm)				(kg)(Karton / Carton)	
252-32714100		600 x 400			Auflagedeckel / Flat lid	0,9 50



ROLLWAGEN

Roller trucks

600 x 400 mm
800 x 600 mm



WERIT Rollwagen werden aus hochwertigem ABS-Kunststoff bzw. ABS/Aluminium hergestellt. Das Montagematerial ist rostfrei. Deshalb können die Rollwagen unbedenklich in der Nahrungsmittelindustrie eingesetzt werden. Die Rollen aus Polyamid (PA) sind mit Fadenschutz ausgestattet. Zu Ihrer Sicherheit trägt jeder Rollwagen das TÜVIGS-Siegel.

WERIT roller trucks are made of high-quality ABS plastics or ABS/aluminium. The mounting material is stainless. That's why the roller trucks can be used safely in the food industries. The polyamide rollers are fitted with threadguards. For your safety every roller truck has the visible TÜVIGS quality mark.

264-39954LB0 ■



264-39957GKL ■



264-39940000 ■



269-39880000 ■



ab 50 Stk
from 50 pcs. up

Standardfarbe / Standard Colour:

siehe Abbildungen / refer to picture

Material: ABS-Rahmen / ABS frames

Ausnahme / Exception:

264-39940000

Aluminium-Profil / profile

Rollen / Roller:

ø 100 mm

andere Ausführung auf Anfrage

other types on inquiry

Version:

D: ABS-Rahmen / ABS frames





F: Aluminium-Profil / profile

G: ABS-Rahmen in Gitterausführung
ABS-frame perforated

7: 4 Lenkrollen / 4 steering rollers

8: 2 Lenk- und 2 Bockrollen

2 steering and 2 frame rollers

Artikel Nr. Article No.	Farbe Colour	für Größen for sizes (mm)	Tragkraft load (kg)	Gewicht Weight (kg)	Version	Palette Pallet (Stk/pcs)
<i>Rollwagen mit ABS-Rahmen / Roller truck with ABS frames</i>						
264-39954LB0	 rot / red	600 x 400	250	2,8	D, 8	10
264-39954L00	 rot / red	600 x 400	250	2,9	D, 7	10
<i>Rollwagen mit ABS-Rahmen in Gitterausführung / Roller truck with ABS frame perforated</i>						
264-39957GKL	 blau / blue	600 x 400	250	3,4	G, 7	10
<i>Rollwagen mit Aluminium-Profil / Roller truck with aluminium profile</i>						
264-39940000	 rot, Alu / red, alu	800 x 600	250	4,1	F, 7	10

269-39880000  Zentrierwinkel / Centring bracket

1 Satz / Set: 4 Stk. / pcs

notwenig für den Einsatz mit Drehstapelbehälter 600 x 400

necessary for use of rotary stacking container 600 x 400



DREHSTAPELBEHÄLTER

Rotary stacking containers



400 x 300 mm
600 x 400 mm
800 x 600 mm



253-43013000 ■



253-43023000 ■



253-43033000 ■



253-34013N00 ■



253-34033N00 ■



253-34053N00 ■



253-43063000 ■



253-43073000 ■



253-43083000 ■



253-34073N00 ■



253-34083N00 ■



253-34093N00 ■

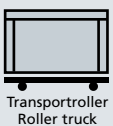

Transportroller
Roller truck



60 % weniger Volumen
60 % less volume



Ergonomischer Griff
Ergonomic handle



Auflast /
Stacking load



Plombe / plombe



Deckel / Lid



Identifikation
Identification



Beschriftung
Marking



Etikettenhalter
Label holder

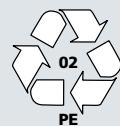

PE



ab 300 Stk
from 300 pcs. up



Standardfarbe / Standard Colour:

- mattweiß, matt-white
- grau, grey
- blau, blue

Material: HDPE

Temp.°C: -30°C bis/to +60°C

Gitterboden / Perforated bottom: 10 x 10 mm

Gitterseite / Perforated sides: 10 x 15 mm

Version:

- A: Boden und Seiten geschlossen
Solid bottom and sides
- B: Boden und Seiten durchbrochen
Perforated bottom and sides
- C: Boden geschlossen, Seiten durchbrochen
Solid bottom, perforated sides
- 2: 2 Grifföffnungen / 2 Handle openings
- * Mindestabnahmemenge 500 Stk
- * Minimum purchase quantity 500 pcs

Artikel Nr. Article No.	Farbe Colour	Außen (mm) External (mm) (A x D x E)	Innen (mm) Internal (mm) (B x C x F)	Volumen Volume (L)	Gewicht Weight (kg)	Version	Palette Pallet (Stk/pcs)
<i>Boden und Seiten geschlossen / Solid bottom and sides</i>							
253- 4301 3000		400 x 300 x 170	328 x 270 x 158	14	0,8	A	
253- 4302 3000		400 x 300 x 220	328 x 270 x 208	18	1,0	A	
253- 4303 3000		400 x 300 x 270	328 x 270 x 258	23	1,2	A	
253- 3401 1N00		600 x 400 x 150	482 x 365 x 147	25	1,5	A, 2	152
253- 3401 3N00		600 x 400 x 150	482 x 365 x 147	25	1,5	A, 2	152
253- 3401 7N00		600 x 400 x 150	482 x 365 x 147	25	1,5	A, 2	152
253- 3402 1N00		600 x 400 x 200	482 x 365 x 196	32	1,8	A, 2	140
253- 3402 3N00		600 x 400 x 200	482 x 365 x 196	32	1,8	A, 2	140
253- 3402 7N00		600 x 400 x 200	482 x 365 x 196	32	1,8	A, 2	140
253- 3403 1N00		600 x 400 x 250	482 x 365 x 248	40	2,2	A, 2	100
253- 3403 3N00		600 x 400 x 250	482 x 365 x 248	40	2,2	A, 2	100
253- 3403 7N00		600 x 400 x 250	482 x 365 x 248	40	2,2	A, 2	100
253- 3404 1N00		600 x 400 x 300	482 x 365 x 297	50	2,4	A, 2	80
253- 3404 3N00		600 x 400 x 300	482 x 365 x 297	50	2,4	A, 2	80
253- 3404 7N00		600 x 400 x 300	482 x 365 x 297	50	2,4	A, 2	80
253- 3405 1N00		600 x 400 x 350	482 x 365 x 348	60	2,7	A, 2	60
253- 3405 3N00		600 x 400 x 350	482 x 365 x 348	60	2,7	A, 2	60
253- 3405 7N00		600 x 400 x 350	482 x 365 x 348	60	2,7	A, 2	60
253- 3416 1000		600 x 400 x 400	480 x 360 x 397	70	2,8	A, 2	60
253- 3416 3000		600 x 400 x 400	480 x 360 x 397	70	2,8	A, 2	60
<i>Boden und Seiten durchbrochen / Perforated bottom and sides</i>							
* 253- 4306 3000		400 x 300 x 170	328 x 270 x 158	14	0,7	B	
* 253- 4307 3000		400 x 300 x 220	328 x 270 x 208	18	0,9	B	
* 253- 4308 3000		400 x 300 x 270	328 x 270 x 258	23	1,1	B	
253- 3406 1N00		600 x 400 x 150	482 x 365 x 147	25	1,3	B, 2	152
253- 3406 3N00		600 x 400 x 150	482 x 365 x 147	25	1,3	B, 2	152
253- 3407 1N00		600 x 400 x 200	482 x 365 x 196	32	1,5	B, 2	140
253- 3407 3N00		600 x 400 x 200	482 x 365 x 196	32	1,5	B, 2	140
253- 3408 1N00		600 x 400 x 250	482 x 365 x 248	40	1,9	B, 2	100
253- 3408 3N00		600 x 400 x 250	482 x 365 x 248	40	1,9	B, 2	100
253- 3409 1N00		600 x 400 x 300	482 x 365 x 297	50	2,1	B, 2	80
253- 3409 3N00		600 x 400 x 300	482 x 365 x 297	50	2,1	B, 2	80
253- 3410 1N00		600 x 400 x 350	482 x 365 x 348	60	2,3	B, 2	60
253- 3410 3N00		600 x 400 x 350	482 x 365 x 348	60	2,3	B, 2	60

Die WERIT Drehstapelbehälter DSBN bezeichnen wir als 2 Phasen Behälter. Leere Behälter sind ineinander nestbar und platz-sparend. Volle Behälter können durch eine 180° Drehung an den Innenkanten aufeinander gestapelt werden, so dass das Füllgut keinen Schaden nimmt.

The WERIT rotary containers DSBN are named as 2 phases container. Empty containers are nestable in each other so they get space-saving. At a 180° turn the container can be stacked at the inside edges on each other so that the filling good does not take any damage.

Besondere Eigenschaften:

- Glatte Innenwände für schnelle und hygienische Reinigung
- 65% Volumenreduzierung
- Hohe Stabilität im Stapel durch Zentrierung
- Gitterabrundung für den schonenden Transport
- Kein Vakuumeffekt beim Entstapeln
- Ergonomische Griffe für mehr Griffsicherheit
- Große Flächen für Heißprägung und Kennzeichnung
- Noppenfelder
- Auf Wunsch mit RFID

Special qualities:

- Smooth inner walls for fast and hygienic cleaning
- 65% reduction of volume
- High stacking stability by centring
- Lattices are rounded for a gently transport
- No vacuum effect when restacking
- Ergonomically designed for increased handling safety
- Large areas for hot stamping and identification marking
- Label fields
- RFID optional

253-34113N00



253-34133N00



253-34153N00



253-43203000



253-34203000



253-37313000

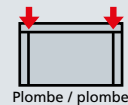
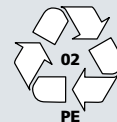
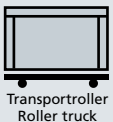

Standardfarbe / Standard Colour:

- mattweiß, matt-white
- grau, grey
- blau, blue

Material: HDPE

Temp.°C: -30°C bis/to +60°C

Gitterboden / Perforated bottom: 10 x 10 mm

Gitterseite / Perforated sides: 10 x 15 mm

Version:

- A: Boden und Seiten geschlossen
Solid bottom and sides
- B: Boden und Seiten durchbrochen
Perforated bottom and sides
- C: Boden geschlossen, Seiten durchbrochen
Solid bottom, perforated sides
- 2: 2 Grifföffnungen / 2 Handle openings
- * Mindestabnahmemenge 500 Stk
* Minimum purchase quantity 500 pcs

Artikel Nr. Article No.	Farbe Colour	Außen (mm) External (mm) (A x D x E)	Innen (mm) Internal (mm) (B x C x F)	Volumen Volume (L)	Gewicht Weight (kg)	Version	Palette Pallet (Stk/pcs)
<i>Boden geschlossen, Seiten durchbrochen, 2 Grifföffnungen / Solid bottom, perforated sides, 2 handle openings</i>							
* 253- 4311 3000	■	400 x 300 x 170	328 x 270 x 158	14		C	
* 253- 4312 3000	■	400 x 300 x 220	328 x 270 x 208	18		C	
* 253- 4313 3000	■	400 x 300 x 270	328 x 270 x 258	23		C	
253- 3411 1N00	□	600 x 400 x 150	482 x 365 x 147	25	1,4	C, 2	152
253- 3411 3N00	■	600 x 400 x 150	482 x 365 x 147	25	1,4	C, 2	152
253- 3412 1N00	□	600 x 400 x 200	482 x 365 x 196	32	1,6	C, 2	140
253- 3412 3N00	■	600 x 400 x 200	482 x 365 x 196	32	1,6	C, 2	140
253- 3413 1N00	□	600 x 400 x 250	482 x 365 x 248	40	2,0	C, 2	100
253- 3413 3N00	■	600 x 400 x 250	482 x 365 x 248	40	2,0	C, 2	100
253- 3414 1N00	□	600 x 400 x 300	482 x 365 x 297	50	2,2	C, 2	80
253- 3414 3N00	■	600 x 400 x 300	482 x 365 x 297	50	2,2	C, 2	80
253- 3415 1N00	□	600 x 400 x 350	482 x 365 x 348	60	2,4	C, 2	60
253- 3415 3N00	■	600 x 400 x 350	482 x 365 x 348	60	2,4	C, 2	60
<i>Deckel / Lids</i>		<i>(mm)</i>			<i>(kg)</i>	<i>(Karton / Carton)</i>	
253- 4320 3000	■	400 x 300	Stülpdeckel / Hooded lid				
253- 3420 1000	□	600 x 400	Stülpdeckel / Hooded lid		0,9		25
253- 3420 3000	■	600 x 400	Stülpdeckel / Hooded lid		0,9		25
253- 3420 7000	■	600 x 400	Stülpdeckel / Hooded lid		0,9		25
253- 3731 3000	■	600 x 400	Klappdeckel / Hinged lid		0,9		25
269- 3992 0000	■		Plombe				100



Bei konisch geformten Behältern weicht das Innenmaß unten von dem oben ab. Gegebenenfalls kann vorab ein Musterbehälter getestet werden. Bei allen Daten und Maßen sind Toleranzen möglich!

The inside dimension from cone-shaped containers differs between the top and the bottom. If necessary a sample container can be pre-tested. Tolerances are possible at all stated data and measures!

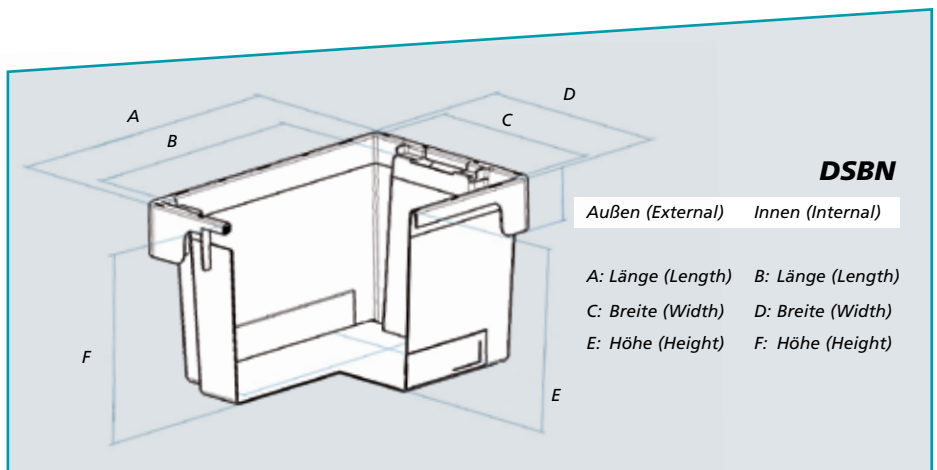

253-37013000 ■



253-37043000 ■



253-37063000 ■



253-37143000 ■



253-37243000 ■



253-37303000 ■



253-37313000 ■



269-39920000 ■

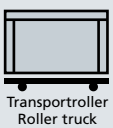

Transportroller
Roller truck



60 % weniger Volumen
60 % less volume



Ergonomischer Griff
Ergonomic handle



Auflast /
Stacking load

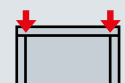

Plombe / plombe



Deckel / Lid



Identifikation
Identification



Beschriftung
Marking

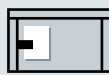

Etikettenhalter
Label holder

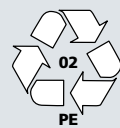

PE



ab 500 Stk
from 500 pcs. up



Besonderheiten der Twistbox:

- Kein Vakuumeffekt beim Entstapeln
- Twistbox mit Rippenboden möglich
- Gitterboden: 10 x 10 mm, Gitterseite: 10 x 15 mm

Special characteristics of the Twistbox:

- No vacuum effect when restacking
- On request with ribbed bottom available
- Perforated bottom: 10 x 10 mm, Perforated side: 10 x 15 mm

Standardfarbe / Standard Colour:

■ grau, grey

Material: HDPE

Temp. °C: -30°C bis/to +60°C

Ausnahme/Exception: 253-37303000
253-37313000

PP (Polypropylen) -20°C bis/to +90°C

Mindestabnahmemenge 500 Stk*

Minimum purchase quantity 500 pcs*

Version:

A: Boden und Seiten geschlossen
Solid bottom and sides

B: Boden und Seiten durchbrochen
Perforated bottom and sides

C: Boden geschlossen, Seiten durchbrochen
Solid bottom, perforated sides

Die Twistbox ist mit DSBn nicht kompatibel!

The Twistbox isn't compatible with DSBn

Artikel Nr. Article No.	Farbe Colour	Außen (mm) External (mm) (A x D x E)	Innen (mm) Internal (mm) (B x C x F)	Volumen Volume (L)	Gewicht Weight (kg)	Version	Palette Pallet (Stk/pcs)
<i>Boden und Seiten geschlossen / Solid bottom and sides</i>							
253-37013000	■	600 x 400 x 150	512 x 365 x 147	28	1,6	A	124
253-37023000	■	600 x 400 x 200	512 x 365 x 197	36	1,9	A	120
253-37033000	■	600 x 400 x 250	512 x 365 x 247	46	2,3	A	92
253-37043000	■	600 x 400 x 300	512 x 365 x 297	56	2,6	A	76
253-37053000	■	600 x 400 x 350	512 x 365 x 347	66	3,0	A	64
253-37063000	■	600 x 400 x 400	512 x 365 x 397	76	3,3	A	56
<i>Boden und Seiten durchbrochen / Perforated bottom and sides</i>							
* 253-37113000	■	600 x 400 x 150	512 x 365 x 147	28	1,3	B	124
* 253-37123000	■	600 x 400 x 200	512 x 365 x 197	36	1,6	B	120
* 253-37133000	■	600 x 400 x 250	512 x 365 x 247	46	1,9	B	92
* 253-37143000	■	600 x 400 x 300	512 x 365 x 297	56	2,2	B	76
* 253-37153000	■	600 x 400 x 350	512 x 365 x 347	66	2,5	B	64
* 253-37163000	■	600 x 400 x 400	512 x 365 x 397	76	2,8	B	56
<i>Boden geschlossen, Seiten durchbrochen, / Solid bottom, perforated sides</i>							
* 253-37213000	■	600 x 400 x 150	512 x 365 x 147	28	1,4	C	124
* 253-37223000	■	600 x 400 x 200	512 x 365 x 197	36	1,7	C	120
* 253-37233000	■	600 x 400 x 250	512 x 365 x 247	46	2,0	C	92
* 253-37243000	■	600 x 400 x 300	512 x 365 x 297	56	2,3	C	76
* 253-37253000	■	600 x 400 x 350	512 x 365 x 347	66	2,6	C	64
* 253-37263000	■	600 x 400 x 400	512 x 365 x 397	76	2,9	C	56
<i>Deckel / Lids</i>		<i>(mm)</i>			<i>(kg)</i>	<i>(Karton / Carton)</i>	
253-37313000	■	600 x 400	Klappdeckel / Hinged lid		0,9		20
269-39920000	■		Plombe				100
253-37303000	■	600 x 400	Stülpdeckel / Hooded lid		1,0		25

WERIT Drehstapelbehälter mit U-Rand überzeugen durch ihre vielseitigen Eigenschaften. Die großen Eckradien und der glatte Boden ermöglichen eine besonders leichte Reinigung sowie einen geräuscharmen Lauf auf Förderanlagen. Die Behälter bieten auf Grund des umlaufenden U-Randes einen besonders hohen Tragekomfort.

WERIT rotary stacking containers with curved lips convince by their versatile qualities. The big corners and the smooth surface make a particularly easy cleaning as well as a quiet run on conveyors possible. The curved lips of the containers allow an easy handling and carrying.

253-31721000



253-31741000



253-31761000



253-31701000



253-31771000



60 % weniger Volumen
60 % less volume



Deckel / Lid



Etikettenhalter
Label holder



Identifikation
Identification

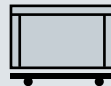

Transportroller
Roller truck



Beschriftung
Marking

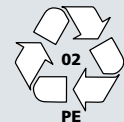

ab 500 Stk
from 500 pcs. up

Standardfarbe / Standard Colour:

- mattweiß, matt-white
- grau, grey
- rot, red

siehe Art. Nr. / refer to Art. No.

Material: HDPE

Temp.°C: -30°C bis/to +60°C

Ausnahme / Exception:

253-31724LL0

Material: LLDPE

Temp.°C: -40°C bis/to +60°C

Version:

- A: Boden und Seiten geschlossen
Solid bottom and sides
 - 9: Wasserabflöcher an der Stirnseite
Water drain holes at the front end
 - 10: Wasserabflöcher an der Längsseite
Water drain holes at the longside
 - 11: Mit Kufen / With skids
 - 12: Mit Füßen / With feet
 - 13: Verstärkter Boden / stabilized bottom
- Die verschiedenen Modellserien
sind nicht kompatibel / The different
series aren't compatible

Artikel Nr. Article No.	Farbe Colour	Außen (mm) External (mm)	Innen (mm) Internal (mm)	Volumen Volume (L)	Gewicht Weight (kg)	Version	Palette Pallet (Stk/pcs)
----------------------------	-----------------	-----------------------------	-----------------------------	--------------------------	---------------------------	---------	--------------------------------

Boden und Seiten geschlossen, Wasserabflöcher an den Stirnseiten, mit Kufen, verstärkter Boden
Solid bottom and sides, waterdrain holes at the front end, with skids, stabilized bottom

253-31721000	<input type="checkbox"/>	600 x 400 x 220	480 x 349 x 213	30	1,8	A, 9	120
253-31723000	<input type="checkbox"/>	600 x 400 x 220	480 x 349 x 213	30	1,8	A, 9	120
253-31724000	<input type="checkbox"/>	600 x 400 x 220	480 x 349 x 213	30	1,8	A, 9	120
253-31724V00	<input type="checkbox"/>	600 x 400 x 220	480 x 349 x 213	30	1,9	A, 9, 11, 13	120
253-31724LL0	<input type="checkbox"/>	600 x 400 x 220	480 x 349 x 213	30	1,8	A, 9	120
253-31731000	<input type="checkbox"/>	600 x 400 x 325	480 x 349 x 319	50	2,1	A, 9	80
253-31733000	<input type="checkbox"/>	600 x 400 x 325	480 x 349 x 319	50	2,1	A, 9	80

Boden und Seiten geschlossen, Wasserabflöcher an der Längsseite, mit Füßen
Solid bottom and sides, water drain holes at the longside, with feet

253-31711000	<input type="checkbox"/>	800 x 600 x 220	638 x 540 x 217	80	4,1	A, 10	40
253-31741000	<input type="checkbox"/>	800 x 600 x 330	638 x 540 x 322	110	5,5	A	30
253-31751000	<input type="checkbox"/>	800 x 600 x 505	638 x 540 x 496	170	8,0	A	20
259-31761000	<input type="checkbox"/>	800 x 600 x 600	638 x 540 x 496	170	8,8	A, 12	16

Deckel / Lids		(mm)		(kg)	(Karton / Carton)
253-31701000	<input type="checkbox"/>	600 x 400	Stülpdeckel / Hooded lid	1,1	25
253-31703000	<input type="checkbox"/>	600 x 400	Stülpdeckel / Hooded lid	1,1	25
253-31771000	<input type="checkbox"/>	800 x 600	Stülpdeckel / Hooded lid	2,7	10



MEHRWEGBEHÄLTER

Multiway containers

300 x 200 mm
400 x 300 mm
600 x 400 mm
800 x 400 mm





254-35067000 ■



254-35517000 ■



254-35307000 ■



254-35187000 ■



Identifikation
Identification



Beschriftung
Marking

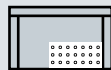

Noppenfeld
rough label field



Plombe / plombe



75 % weniger Volumen
75 % less volume

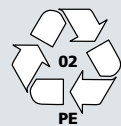

WERIT Mehrwegbehälter sind als Transport-, Lager- und Kommissionierboxen konzipiert und förderstreckentauglich. Die Behälter sind leer Raum sparend ineinander stapelbar und mit Stapelbügel oder anscharniertem Klappdeckel aufeinander stapelbar. Der Klappdeckel ist bandagier- und plombier-fähig.

WERIT multiway containers are designed as transport-, storage- and commissioning boxes and suitable for haulage ways. The empty containers can be stacked in each other to save space. When fitted with stacking mechanism or hinged lid they can also be stacked on top of each other. The hinged lid can be strapped and sealed.

Standardfarbe / Standard Colour:

■ Taubenblau, dove blue

Material: PP

Temp. °C: -20°C bis/to +90 °C

Version:

A: Boden und Seiten geschlossen

Solid bottom and sides

H: Behälter mit Stapelbügel

Container with stacking mechanism

i: Behälter mit Klappdeckel

Container with hinged lid

Artikel Nr. Article No.	Farbe Colour	Außen oben External top (mm)	Außen unten External bottom (mm)	Höhe High (mm)	Volumen Volume (L)	Gewicht Weight (kg)	Version	Palette Pallet (Stk/pcs)
<i>Boden und Seiten geschlossen / Solid bottom and sides</i>								
254-35017000	■	300 x 200	220 x 140	153	5	0,5	A	240
254-35037000	■	400 x 300	320 x 240	173	16	0,8	A	240
254-35047000	■	400 x 300	320 x 240	223	18	1,0	A	240
254-35057000	■	400 x 300	320 x 240	273	22	1,2	A	200
254-35067000	■	400 x 300	320 x 240	323	27	1,3	A	160
254-35077000	■	600 x 400	505 x 335	173	29	1,7	A	140
254-35087000	■	600 x 400	505 x 335	223	38	1,9	A	136
254-35097000	■	600 x 400	505 x 335	273	47	2,2	A	104
254-35107000	■	600 x 400	505 x 335	323	58	2,6	A	80
254-35117000	■	600 x 400	505 x 335	423	74	3,6	A	64
254-35137000	■	800 x 400	705 x 335	323	76	3,7	A	60
254-35147000	■	800 x 400	705 x 335	423	100	4,5	A	48
<i>Behälter mit Stapelbügel / Container with stacking mechanism</i>								
254-35437000	■	400 x 300	320 x 240	173	16	1,0	H	240
254-35447000	■	400 x 300	320 x 240	223	18	1,1	H	240
254-35457000	■	400 x 300	320 x 240	273	22	1,4	H	200
254-35467000	■	400 x 300	320 x 240	323	27	1,5	H	160
254-35477000	■	600 x 400	505 x 335	173	29	1,9	H	140
254-35487000	■	600 x 400	505 x 335	223	38	2,1	H	136
254-35497000	■	600 x 400	505 x 335	273	47	2,4	H	104
254-35507000	■	600 x 400	505 x 335	323	58	2,8	H	80
254-35517000	■	600 x 400	505 x 335	423	74	3,8	H	64
254-35537000	■	800 x 400	705 x 335	323	76	3,9	H	60
254-35547000	■	800 x 400	705 x 335	423	100	4,8	H	48
<i>Behälter mit Klappdeckel / Container with hinged lid</i>								
254-35217000	■	310 x 200	220 x 140	170	5	0,7	i	240
254-35237000	■	410 x 300	320 x 240	190	16	1,3	i	120
254-35247000	■	410 x 300	320 x 240	240	18	1,4	i	156
254-35257000	■	410 x 300	320 x 240	290	22	1,7	i	120
254-35267000	■	410 x 300	320 x 240	340	27	1,8	i	114
254-35277000	■	610 x 400	505 x 335	190	29	2,6	i	114
254-35287000	■	610 x 400	505 x 335	240	38	2,7	i	104
254-35297000	■	610 x 400	505 x 335	290	47	3,1	i	80
254-35307000	■	610 x 400	505 x 335	340	58	3,4	i	76
254-35317000	■	610 x 400	505 x 335	440	74	4,5	i	56
254-35337000	■	810 x 400	705 x 335	340	76	4,8	i	57
254-35347000	■	810 x 400	705 x 335	440	100	5,7	i	42
<i>Deckel / Lids</i>		<i>(mm)</i>				<i>(kg)</i>		<i>(Karton / Carton)</i>
254-35167000	■	306 x 206	Stülpdeckel / Hooded lid			0,2		-
254-35177000	■	400 x 300	Stülpdeckel / Hooded lid			0,5		-
254-35187000	■	600 x 400	Stülpdeckel / Hooded lid			1,0		-
254-35197000	■	800 x 400	Stülpdeckel / Hooded lid			1,5		-



BECKEN UND KÄSTEN

Tubes and boxes

Sonderabmessungen
Special dimensions





255-31051000 



255-31311000 



256-31521000 



255-31511000 



256-31781000 

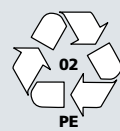

WERIT Becken und Kästen:

- Umlaufender U-Rand
- Besonders stabil
- Hoher Tragekomfort
- Innenwände sind glatt und abgerundet – das ermöglicht die einfache Reinigung
- Konische Form – im Leerzustand Platz sparend ineinander stapelbar
- Boden wird durch Verstärkungsrippen vor Abrieb geschützt

WERIT Tubs and boxes:

- All around curved lips
- Extremely solid
- High carrying comfort
- Smooth and rounded inner walls for easy cleaning
- Space-saving stacking in each other when empty because of conical design
- Bottom protected against attrition by means of reinforced ribs

Standardfarbe / Standard Colour:

mattweiß, matt-white
Ausnahme / Exception:
252-3151..., 255-3152... auch in / also in
 grau, grey

Material: HDPE

Temp.°C: -30°C bis/to +60°C

Version:

J: Becken / Tubs

K: Kasten / Box

Artikel Nr. Article No.	Farbe Colour	Außen (mm) External (mm)	Innen (mm) Internal (mm)	Volumen Volume (L)	Gewicht Weight (kg)	Version	Palette Pallet (Stk/pcs)
Becken / Tubs							
255-31051000	<input type="checkbox"/>	440 x 320 x 155	395 x 275 x 150	12	0,8	J	200
255-31131000	<input type="checkbox"/>	610 x 440 x 150	550 x 375 x 145	25	1,3	J	200
255-31311000	<input type="checkbox"/>	710 x 490 x 185	635 x 420 x 175	40	1,7	J	200
Kasten / Box							
255-31511000	<input type="checkbox"/>	535 x 475 x 380	450 x 395 x 360	55	3,3	K	40
255-31513000	<input type="checkbox"/>	535 x 475 x 380	450 x 395 x 360	55	3,3	K	40
256-31781000	<input type="checkbox"/>	750 x 490 x 310	680 x 440 x 300	90	3,4	K	40
Deckel / Lids		(mm)			(kg)	(Karton / Carton)	
256-31521000	<input type="checkbox"/>	535 x 475	Stülpdeckel / Hooded lid für 255-31511000		1,1		11
256-31523000	<input type="checkbox"/>	535 x 475	Stülpdeckel / Hooded lid für 255-31513000		1,1		11



STAPELKÄSTEN UND SCHALEN

Stacking crates and trays

Sonderabmessungen
Special dimensions



255-31028000



256-31041000



256-31031000



256-31303000



256-31163000



257-31141000



256-31103000



256-31173000



Deckel / Lid



Etikettenhalter
Label holder



Identifikation
Identification



Beschriftung
Marking

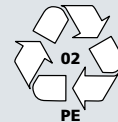

WERIT Stapelkästen und Schalen – Die richtige Wahl, wenn nicht das Modulmaß im Vordergrund steht.

WERIT stacking crates and trays – The right choice whenever the modular dimension is not the main aspect.

Standardfarbe / Standard Colour:

- mattweiß, matt-white
 grau, grey

Material: HDPE

Temp.°C: -30°C bis/to +60°C

Ausnahme / Exception: 255-31028000

Material: PS (Polystyrol / Polystyrene)

Version:

L: Stapelkasten / Stacking crate

M: Thekenschale / Counter trays

T: Fertigwaren Karree / Crate with special dimension

Artikel Nr. Article No.	Farbe Colour	Außen (mm) External (mm)	Innen (mm) Internal (mm)	Volumen Volume (L)	Gewicht Weight (kg)	Version	Palette Pallet (Stk/pcs)
<i>Thekenschale / Counter trays</i>							
255-31028000	<input type="checkbox"/>	355 x 255 x 40	350 x 250 x 38	3	0,3	M	
<i>Stapelkasten / Stacking crate</i>							
256-31041000	<input type="checkbox"/>	450 x 255 x 105	400 x 210 x 100	8	0,6	L	150
256-31043000	<input type="checkbox"/>	450 x 255 x 105	400 x 210 x 100	8	0,6	L	150
256-31061000	<input type="checkbox"/>	450 x 295 x 70	400 x 245 x 65	7	0,7	L	200
256-31063000	<input type="checkbox"/>	450 x 295 x 70	400 x 245 x 65	7	0,7	L	200
256-31031000	<input type="checkbox"/>	450 x 295 x 125	400 x 245 x 120	10	0,8	L	100
256-31033000	<input type="checkbox"/>	450 x 295 x 125	400 x 245 x 120	10	0,8	L	100
256-31071000	<input type="checkbox"/>	465 x 360 x 82	420 x 315 x 80	10	0,8	L	150
256-31091000	<input type="checkbox"/>	525 x 455 x 110	470 x 400 x 105	18	1,4	L	80
256-31093000	<input type="checkbox"/>	525 x 455 x 110	470 x 400 x 105	18	1,4	L	80
256-31201000	<input type="checkbox"/>	525 x 455 x 165	470 x 400 x 160	30	1,8	L	48
256-31203000	<input type="checkbox"/>	525 x 455 x 165	470 x 400 x 160	30	1,8	L	48
256-31301000	<input type="checkbox"/>	525 x 455 x 220	470 x 400 x 215	40	2,1	L	40
256-31303000	<input type="checkbox"/>	525 x 455 x 220	470 x 400 x 215	40	2,1	L	40
256-31181000	<input type="checkbox"/>	580 x 360 x 100	525 x 310 x 95	15	1,3	L	80
256-31183000	<input type="checkbox"/>	580 x 360 x 100	525 x 310 x 95	15	1,3	L	80
256-31161000	<input type="checkbox"/>	580 x 360 x 215	525 x 310 x 210	35	2,0	L	40
256-31163000	<input type="checkbox"/>	580 x 360 x 215	525 x 310 x 210	35	2,0	L	40
256-31141000	<input type="checkbox"/>	580 x 470 x 120	530 x 430 x 115	26	1,7	L	60
** 256-31143000	<input type="checkbox"/>	580 x 470 x 120	530 x 430 x 115	26	1,7	L	60
<i>Fertigwaren Karree / Crate with special dimension</i>							
* 257-31151000	<input type="checkbox"/>	730 x 480 x 90	685 x 430 x 80	20	2,1	T	50
<i>Deckel / Lids</i>		(mm)			(kg)		(Karton / Carton)
256-31101000	<input type="checkbox"/>	525 x 455	Stülpdeckel / Hodded lid		0,90		16
256-31103000	<input type="checkbox"/>	525 x 455	Stülpdeckel / Hodded lid		0,90		16
256-31171000	<input type="checkbox"/>	580 x 360	Stülpdeckel / Hodded lid		1,00		17
256-31173000	<input type="checkbox"/>	580 x 360	Stülpdeckel / Hodded lid		1,00		17

Mindestabnahmemenge 1000 Stk*/300 Stk**

Minimum purchase quantity 1000 pcs*/300 Stk**



RUNDBEHÄLTER, TONNEN UND EIMER

Round containers, barrels and buckets

verschiedene Ø
special Ø



258-32411000



258-31541000



258-45221000



260-31811000



260-31691000



260-31831000



Deckel für / Lid for:
260-31811000 / 260-31821000

260-31681000



Deckel für / Lid for:
260-31691000 / 260-31671000

261-31681S000



Schnappdeckel für / snap-on-lid for:
260-31691000 / 260-31671000

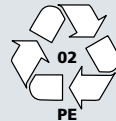

Die richtige Wahl für die Lagerung von Flüssigkeiten und Schüttgütern.

Rundbehälter, Tonnen und Eimer haben eine konische Form und sind somit leer ineinander stapelbar für eine platz sparende Lagerung. Glatte Innenwände ermöglichen eine schnelle und einfache Reinigung.

The best choice for storing liquids and bulk goods.

Due to their conical design, empty round containers, barrels and buckets are stackable one in each other for a space-saving storage. Smooth inside walls make a fast and simple cleaning possible.

Standardfarbe / Standard Colour:

mattweiß, matt-white

Material: HDPE

Temp. °C: -30°C bis/to +60°C

Version:

N: Rundbehälter / Round Container

O: Eimer mit Literskala
Bucket with graduated scale in litres

P: Tonne / Barrels

14: 2 Handgriffe / 2 handels

15: 2 Muschelgriffe / 2 shell-form handels

16: Bügel, verzinkt
Zinc-plated handle

17: Bügel, Edelstahl
Stainless steel handle

Artikel Nr. Article No.	Farbe Colour	Außen / External oben, unten, Höhe top, bottom, height (mm)	Innen / Inside oben, unten, Höhe top, bottom, height (mm)	Volumen Volume (L)	Gewicht Weight (kg)	Version	Palette Pallet (Stk/pcs)
<i>Rundbehälter, 2 Handgriffe / Round container, 2 handels</i>							
258-32411000	<input type="checkbox"/>	550, 380, 350	485, 370, 345	50	2,1	N, 14	60
<i>Rundbehälter, 2 Muschelgriffe / Round container, 2 shell-form handels</i>							
258-31541000	<input type="checkbox"/>	590, 470, 335	540, 460, 330	65	2,4	N, 15	58
258-31661000	<input type="checkbox"/>	635, 510, 385	580, 500, 380	85	3,2	N, 15	54
<i>Eimer mit Literskala, Bügel verzinkt, Bügel Edelstahl / Bucket with graduated scale in litres / Zinc-plated handle, Stainless steel handle</i>							
258-45211000	<input type="checkbox"/>	325, 215, 267	–	12	0,7	O, 16	300
258-45221000	<input type="checkbox"/>	325, 215, 267	–	12	0,7	O, 17	300
<i>Tonne, 2 Handgriffe / Barrels, 2 handels</i>							
260-31811000	<input type="checkbox"/>	420, 335, 445	370, 330, 425	40	1,7	P, 14	80
260-31821000	<input type="checkbox"/>	420, 330, 540	370, 325, 520	50	2,0	P, 14	75
260-31691000	<input type="checkbox"/>	515, 410, 530	455, 400, 512	75	3,7	P, 14	36
260-31671000	<input type="checkbox"/>	515, 430, 733	460, 420, 725	110	5,5	P, 14	24
<i>Deckel / Lids</i>		(mm)			(kg)	(Karton / Carton)	
260-31831000	<input type="checkbox"/>	428	Deckel / lid		0,30		–
260-31681000	<input type="checkbox"/>	534	Deckel / lid		0,90		–
260-31681S00	<input type="checkbox"/>	525	Schnappdeckel / Snap-on-lid		0,90		–



WARENKÖRBE

Baskets

575 x 375 mm

710 x 400 mm

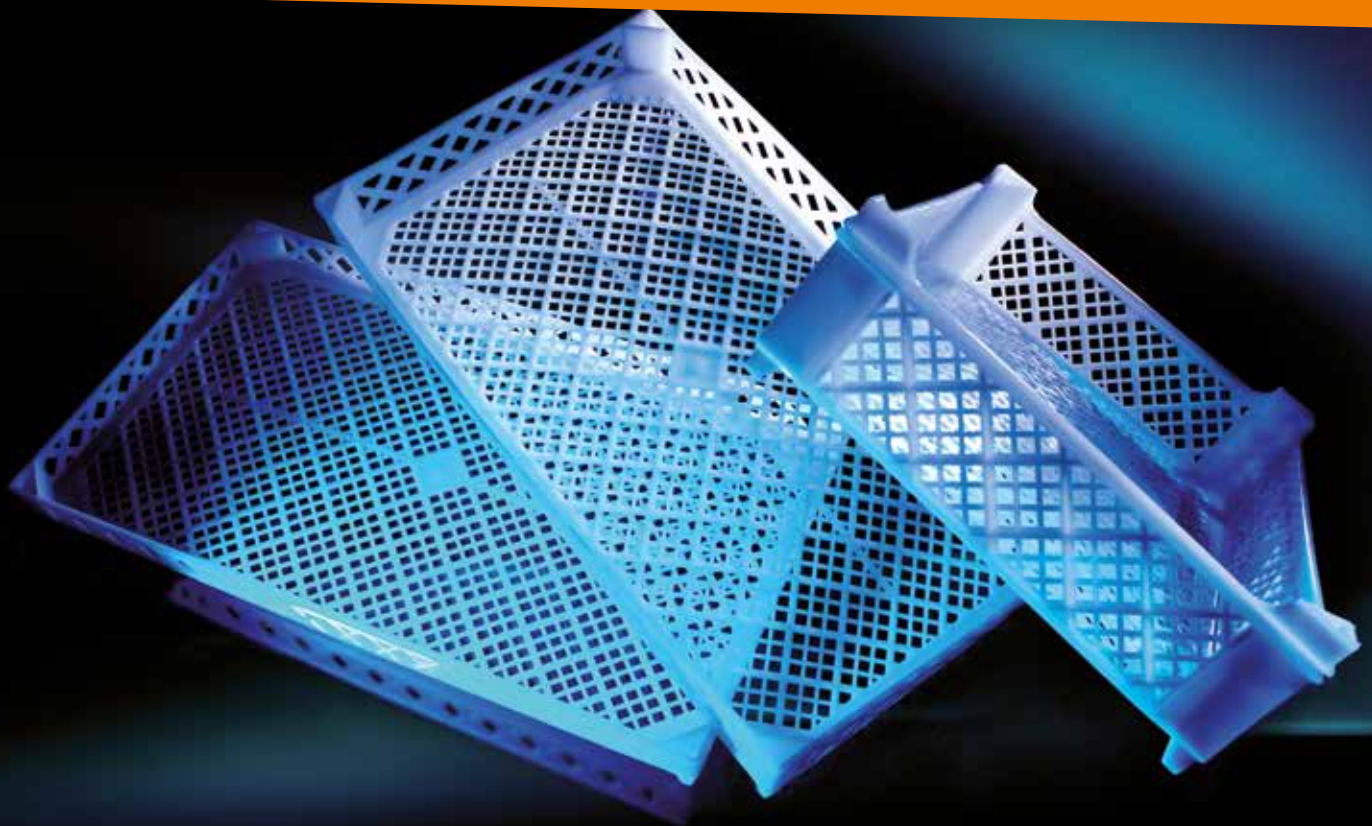



257-33371000

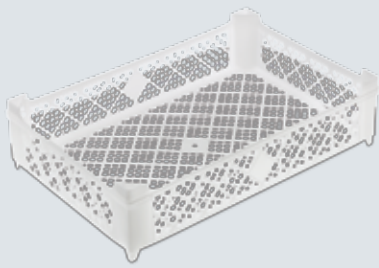

257-33351000

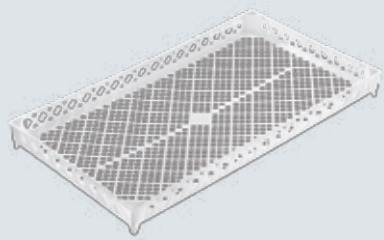

257-33381000

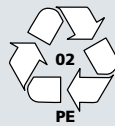
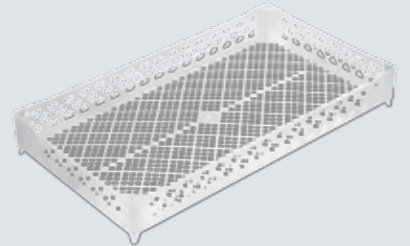

WERIT Warenkörbe eignen sich besonders für den Einsatz in der Süßwarenindustrie.

Durch die Stapellecken sind sie sicher aufeinander stapelbar. Die gute Luftzirkulation ermöglicht ein optimales Temperieren der Ware z. B. zum Erwärmen oder Abkühlen.

WERIT baskets are particularly suitable for the confectionery industry.

The baskets can be safely stacked on top of each other by means of stacking corners. Products can be optimally heated or cooled due to the good air circulation properties.

Standardfarbe / Standard Colour:

mattweiß, matt-white

Material: HDPE

Temp. °C: -30°C bis/to +60°C

Mindestabnahmemenge: 1000 Stk

Minimum purchase quantity: 1000 pcs

Version:

B: Boden und Seiten durchbrochen
Perforated bottom and sides

18: Gittergröße / Perforation size:

a) 10 x 10 mm

b) Seiten / sides: 18 x 18 mm

Boden / bottom: 10 x 10 mm

Artikel Nr. Article No.	Farbe Colour	Außen (mm) External (mm)	Innen (mm) Internal (mm)	Volumen Volume (L)	Gewicht Weight (kg)	Version	Palette Pallet (Stk/pcs)
<i>Boden und Seiten durchbrochen, Gittergröße 10 x 10 mm / Perforated bottom and sides, Perforation size 10 x 10 mm</i>							
257-33371000	<input type="checkbox"/>	575 x 375 x 100	560 x 360 x 95	20	1,2	B, 18a	60
<i>Boden und Seiten durchbrochen, Gittergröße Seiten 18 x 18 mm, Gittergröße Boden 10 x 10 mm Perforated bottom and sides, Perforation size sides 18 x 18 mm, Perforation size bottom 10 x 10 mm</i>							
257-33351000	<input type="checkbox"/>	710 x 400 x 40	700 x 390 x 35	11	0,9	B, 18b	120
257-33381000	<input type="checkbox"/>	710 x 400 x 70	700 x 400 x 65	18	1,1	B, 18b	75



GROSSBEHÄLTER

Large containers

140–650 Liter





259-31901000



259-31921000



259-31941000



259-31881000



259-31881D00

259-31891D00



269-3189FG00

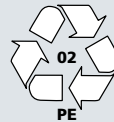
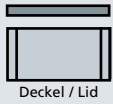
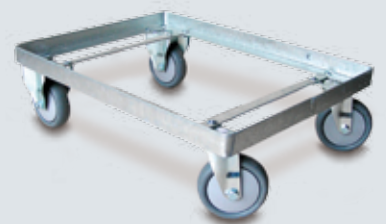

WERIT Großbehälter sind die richtige Wahl bei schwerem Füllgut. Glatte, abgerundete Innenwände ermöglichen eine leichte und schnelle Reinigung.

Großbehälter 210 l, 360 l und 650 l können auf Wunsch mit Spundloch und Gummistopfen oder Ablaufhahn ausgestattet werden.

Large containers of WERIT are the best choice for heavy charges. Smooth, rounded inside walls make an easy and fast cleaning possible.

Large containers of 210 ltrs., 360 ltrs. and 650 ltrs. are on request available with bunghole and drain plug or liquids outlet.

Standardfarbe / Standard Colour:

mattweiß, matt-white

Material: HDPE

Temp. °C: -30°C bis/to +60°C

Version:

Q: Großbehälter / Large Container

7: 4 Lenkrollen, PP mit Fadenschutz

4 steering rollers, PP with thread guard

8: 2 Lenk- und 2 Bockrollen

2 steering and 2 frame rollers

12: Mit Füßen / With feet

13: Verstärkter Boden / stabilized bottom

Artikel Nr. Article No.	Farbe Colour	Außen (mm) External (mm)	Innen (mm) Internal (mm)	Volumen Volume (L)	Gewicht Weight (kg)	Version	Palette Pallet (Stk/pcs)
<i>Großbehälter / Large container</i>							
259-31901000	<input type="checkbox"/>	800 x 600 x 405	720 x 515 x 400	140	10,4	Q	10
<i>Großbehälter, verstärkter Boden / Large container, stabilized bottom</i>							
259-31901V00	<input type="checkbox"/>	800 x 600 x 415	720 x 515 x 400	140	11,4	Q, 13	10
<i>Großbehälter, verstärkter Boden, 2 Lenk- und 2 Bockrollen / Large container, stabilized bottom, 2 steering and 2 frame rollers</i>							
259-31921000	<input type="checkbox"/>	800 x 600 x 550	720 x 515 x 400	140	15,0	Q, 8, 13	10
<i>Großbehälter, 4 Lenkrollen PP mit Fadenschutz, verstärkter Boden, / Large container, 4 steering rollers PP with thread guard, stabilized bottom</i>							
259-31921001	<input type="checkbox"/>	800 x 600 x 550	720 x 515 x 400	140	15,0	Q, 7, 13	10
<i>Großbehälter, mit Füßen, verstärkter Boden / Large container, with feet, stabilized bottom</i>							
259-31941000	<input type="checkbox"/>	800 x 600 x 510	720 x 515 x 400	140	12,0	Q, 12, 13	10
<i>Deckel / Lids</i>		(mm)			(kg)	(Karton / Carton)	
259-31951000	<input type="checkbox"/>	800 x 600	Deckel / Lid		3,0		10
<i>Großbehälter, mit Füßen / Large container, with feet</i>							
259-31881000	<input type="checkbox"/>	790 x 605 x 685	725 x 540 x 575	210	8,9	Q, 12	22
259-31891000	<input type="checkbox"/>	945 x 725 x 830	875 x 655 x 705	360	17,4	Q, 12	6
259-31911000	<input type="checkbox"/>	1195 x 905 x 835	1120 x 830 x 705	650	24,0	Q, 12	5
<i>Deckel / Lids</i>		(mm)	für / for		(kg)	(Karton / Carton)	
259-31881D00	<input type="checkbox"/>	804 x 625 x 40	259-31881000		3,0		–
259-31891D00	<input type="checkbox"/>	952 x 745 x 47	259-31891000		5,0		–
259-31911D00	<input type="checkbox"/>	1255 x 995 x 65	259-31911000		9,0		–
<i>Deckel / Lids</i>		(mm)			(kg)	(Karton / Carton)	
269-3188FG00	<input type="checkbox"/>	für 210	Fahrgestell verzinkt / Trolley galvanized		–		–
269-3189FG00	<input type="checkbox"/>	für 360	Fahrgestell verzinkt / Trolley galvanized		–		–
<i>(Edelstahl auf Wunsch / stainless steel on request)</i>							

SPEZIFISCHE LÖSUNGEN UND IDENTIFIKATION

Custom-designed solutions and identification



Viele unserer Produkte müssen speziellen Anforderungen entsprechen. Dafür werden Serienprodukte den Wünschen unserer Kunden angepasst.

Ob Heißprägung oder eine andere Form der Identifikation, ob sie Ihren Behälter in der Firmenfarbe oder aus einem speziellen Material wie dem antimikrobiellen Kunststoff unserer STERiline Produktion (siehe Bilder unten) benötigen, sprechen Sie uns an. Ab der zum Produkt angegebenen Mindest-Stückzahl für eine Sonderproduktion ist vieles möglich.

Many of our products must meet special requirements. For this series products are adapted to the specifications our customers.

Contact us, no matter whether you want your crate or container hot embossed or with another kind of ID, in your company colours or made of a special material such as the antimicrobial plastic from our STERiline range (see photos below). Almost anything goes from the minimum quantity specified for the product for customised production.

Speziallösung - Farbe und Material / Special edition - colour and material



- | kein toxischer Effekt / no toxic effect
- | keine Migration der Additive / no additive migration
- | keine Nanopartikel / no nano-particles
- | nachhaltig wirksam bei einer kurzen Einwirkzeit / sustained effect with a short action time

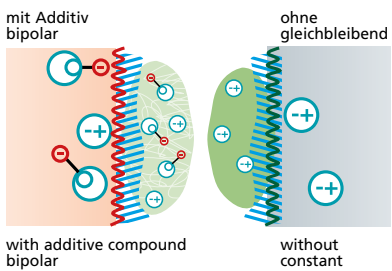

with additive compound bipolar

without constant

Keimdichte, Keimkonzentrationen und Vielfalt der Keime nehmen kontinuierlich zu. Entsprechend wachsen die Anforderungen an die Hygiene der involvierten Verpackungen. Alle produktberührenden Flächen des Behälters sind so ausgeführt, dass durch ein spezielles Additiv eine Verunreinigung des Füllmediums durch die meisten Algen, Bakterien, Pilze und Viren nicht stattfinden kann bzw. eine automatische Selbstreinigung erfolgt. Dabei werden weder chemische Biozide noch leicht flüchtige Nanowerkstoffe eingesetzt. Algen, Bakterien, Pilze und Viren werden durch Aufbau und Reaktivität des Additivs vernichtet.

The density, concentration and variety of germs is increasing all the time. Hygiene requirements for the packaging involved are increasing accordingly. All the surfaces of the container which come into contact with the product have been designed in such a way that there can be no contamination of the bulk goods by most algae, bacteria, fungi and viruses and/or that automatic self-cleaning takes place. Neither chemical biocides nor highly volatile nano materials are used. Algae, bacteria, fungi and viruses are destroyed by the structure and reactivity of the additive.

physikalischer Effekt / physical effect
 durch externe Labore geprüft und bestätigt /
 tested and confirmed by external laboratories

Heißprägung / Hot stamping



Heißprägung

- Normschrift
- Alpha-numerisch, numerisch, fortlaufend
- Kundenlogo

Hot stamping

- Standard lettering
- Alpha-numerical, numerical, consecutively
- Customer's logo

Maschinenprägung / Machine stamping



Siebdruck / Screen printing



Labels, Barcodes



RFID-Transponder



- **Maschinenprägung**
- **Siebdruck**
- **Etiketten/Barcodes**
- **RFID Transponder**

- **Machine stamping**
- **Screen printing**
- **Labels/barcodes**
- **RFID Transponder**

Verschlüsse / Closures



Schnappverschluss / Snap lock



Scharnierverschluss / Hinged closure



Schiebeverschluss / Slide closure



Etikettenhalter / Label holder



Etikettenhalter, lang
 Label holder, long

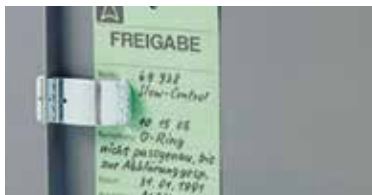

Etikettenhalter, kurz
 Label holder, short



Etikettenhalter, angespritzt
 Label holder, moulded on

- Etikettentasche transparent (ohne Abb.)
 - nach 3 Seiten offen
 - für eine häufig wechselnde Etikettierung
 - Gewebeklebeband mit starker Haftkraft
 Label holder transparent (ohne Abb.)
 - 3 open sides
 - for frequent stock up dates
 - fitted with strong adhesive fabrik tape

Weitere Details / More Details



Rippenboden / Ribbed bottom



Detail Scharnier / Hinge detail



Noppenfeld / Rough label field



Ausfräsung / Cutout

Chemikalie / Chemical	Konzentration / Concentration	HDPE	PP
Acetaldehyd / acetaldehyde		3/3	3/4
Acetamid / acetamide	gesättigt / saturated	1/1	1/1
Aceton / acetone		1/1	1/3
Acetonitril / acetonitrile		1/1	3/4
Acetophenon / acetophenone		0/0	1/3
Acetylen / acetylene	100 %	1/0	1/0
Acrylnitril / acrylonitrile		1/1	3/4
Adipinsäure / adipic acid	gesättigt / saturated	1/1	1/1
Allylkohol / allyl alcohol	96 %	1/3	2/2
Aluminiumchlorid / aluminium chloride	10 %	1/1	1/1
Aluminiumoxid / aluminium oxide	fest / solid	1/1	1/1
Ameisensäure / formic acid	98-100 %	1/1	1/3
Aminosäuren / amino acids		1/1	1/1
Ammoniak / ammonia	25 %	1/1	1/1
Ammoniumchlorid / ammonium chloride	wässrig / liquid	1/1	1/1
Ammoniumhydroxid / ammonium hydroxide	5 %	1/1	1/1
Ammoniumoxalat / ammonium oxalate		1/1	1/2
Ammoniumphosphat / ammonium phosphate	jede / each	1/1	1/1
Ammoniumsulfid / ammonium sulphide	jede / each	1/1	1/1
Amylacetat (Pentylacetate) / amyl acetate (pentyl acetate)		1/2	3/4
Amylkohol / amyl alcohol		1/1	1/1
Anilin / aniline		1/2	2/3
Bariumchlorid / barium chloride	gesättigt / saturated	1/1	1/1
Benzaldehyd / benzaldehyde		1/3	1/4
Benzin / petrol		2/3	3/4
Benzoessäure / benzoic acid	gesättigt / saturated	1/1	1/3
Benzol / benzene		3/4	3/4
Benzylalkohol / benzyl alcohol		3/4	4/4
Blausäure / hydrocyanic acid	wässrig / liquid	1/1	1/1
Bleiacetat / lead acetate	wässrig / liquid	1/1	1/1
Borsäure / boric acid	10 %	1/1	1/1
Bremsflüssigkeit / brake fluid		1/0	1/1
Brom / bromine		4/4	4/4
Brombenzol / bromobenzene		3/4	4/4
Bromwasserstoffsäure / hydrobromic acid	50 %	1/1	1/2
Butadien / butadiene		3/4	4/4
Butanol / butanol	techn. rein / technically pure	1/1	1/2
Buttersäure / butyric acid		3/4	4/4
Butylacetat / butyl acetate		1/2	3/4
Calciumchlorid / calcium chloride	wässrig / liquid	1/1	1/1
Calciumhydroxid / calcium hydroxide	konz. / conc.	1/1	1/1
Calciumhypochlorid / calcium hypochloride	gesättigt / saturated	1/1	1/1
Calciumsulfat / calcium sulphate	gesättigt / saturated	1/1	1/1
Carbazol / carbazole		1/1	1/1
Cellosolveacetat / cellosolve acetate		1/1	1/2
Chlor / chlorine	10 % naß / 10 % wet	3/4	4/4
Chlorbenzol / chlorobenzene		3/4	3/4

Chemikalie / Chemical	Konzentration / Concentration	HDPE	PP
Chloroform / chloroform		3/4	2/3
Chlorwasser / chlorinated water		3/0	3/4
Chromsäure / chromic acid	10 %	1/1	1/1
Citronensäure / citric acid	10 %	1/1	1/1
Cyclohexan / cyclohexane		3/4	3/4
Decahydronaphthalin (Decalin) / decahydronaphtalene (decalin)		1/2	2/4
Dibutylphthalat / dibutyl phthalate		1/3	2/2
Dichlorbenzol / dichlorobenzene		3/3	3/4
Diethylbenzol / diethylbenzene		3/4	4/4
Diethylether / diethylether		3/4	4/4
Dimethylformamid / dimethylformamide		1/1	1/1
Dioxin 1,4 / dioxin 1.4		2/2	3/3
Eisessig / glacial acetic acid		0/0	1/3
Essigsäure / acetic acid	50 %	1/1	1/1
Essigsäuremethylester / methyl acetate	100 %	1/0	1/3
Ethanol / ethanol	50 %	1/1	1/1
Ether / ether		3/4	4/4
Ethylacetat / ethyl acetate		1/3	1/3
Ethylacrylat / ethyl acrylate	100 %	4/4	4/4
Ethylalkohol / ethyl alcohol	96 %	1/1	1/1
Ethylbenzol / ethylbenzene		2/3	3/4
Ethylchlorid / ethylchloride		3/3	3/4
Ethylencyanacetat / ethyl cyanacetate		1/1	1/1
Ethylenglykol / ethylene glycol		1/1	1/1
Ethylenoxid / ethylene oxide		2/3	3/3
Ethylether / ethyl ether	techn. rein / technically pure	3/0	4/4
Fluor / fluorine		4/4	4/4
Fluoride / fluoride		1/1	1/1
Flußsäure / hydrofluoric acid	50 %	1/1	1/1
Formaldehyd / formaldehyde	40 %	1/2	1/2
Fotoentwickler / photographic developer		1/3	1/2
Fotofixierbäder / photographic fixer		1/0	1/1
Frostschutzmittel (KFZ) / antifreeze (car)		1/1	1/1
Glukose / glucose	jede / each	1/1	1/1
Glycerin / glycerine	jede / each	1/1	1/1
Harnstoff (Carbamid u. a.) / urea (carbamide & others)		1/1	1/1
Heizöl / heating oil		3/3	1/3
Heptan, n- / heptane, n-		2/3	2/4
Hexan / hexane		2/3	2/3
Hydrazinhydrat / hydrazine hydrate	wässrig / liquid	1/1	1/1

Chemikalie / Chemical	Konzentration / Concentration	HDPE	PP
Isopropanol (Isopropylalkohol) / isopropanol (isopropyl alcohol)	techn.rein / technically pure	1/1	1/1
Isopropylacetat / isopropyl acetate		1/2	2/3
Jod (J)-Tinktur / iodine (I)-tincture		1/3	1/2
Kallilauge (Kaliumhydroxid) / potassium hydroxide 50 %		1/1	1/1
Kaliumperchlorat / acetalddehyde	gesättigt / saturated	1/1	1/1
Kaliumpermanganat / potassium perchlorate		1/3	1/1
Kerosin / kerosine		2/2	3/3
Königswasser / aqua regia		4/4	4/4
Kohlendioxid / carbon dioxide		1/1	1/1
Kresol / cresol		3/4	2/3
Lanolin / lanolin	techn. rein / technically pure	1/3	1/3
Maschinenöl / machine oil	100 %	0/0	1/3
Menthol / menthol	100 %	1/3	1/3
Metallsalze / metal salts	gelöst / dissolved	1/1	1/1
Methanol (Methylalkohol) / methanol (methyl alcohol)		1/1	1/1
Methoxyethyloleat / methyl ethyl oleate		1/1	1/2
Methylethylketon / methyl ethyl ketone		1/3	1/3
Methylenchlorid / dichloromethane		4/4	3/4
Milchsäure / lactic acid	85 %	1/1	1/2
Mineralöl / mineral oil		1/1	1/3
Monochloressigsäure / monochloroacetic acid		1/1	1/2
Natriumacetat / sodium acetate	jede / each	1/1	1/1
Natriumcarbonat / sodium carbonate		1/1	1/1
Natriumchlorid / sodium chloride	jede / each	1/1	1/1
Natriumdichromat / sodium dichromate		0/0	1/1
Natriumhydroxyd / sodium hydroxide	50 %	1/1	1/1
Natriumhypochlorid / sodium hypochloride	15 %	1/1	1/1
Natriumhypochlorid / sodium hypochloride	50 %	3/3	3/3
Natronlauge / caustic soda	30 %	1/1	1/1
Nitrobenzol / nitrobenzene		3/4	2/4
Octan, -n / octane, -n		1/1	1/1
Öle und Fette, vegetabil / oil and fat, vegetable		1/3	1/3
Oxalsäure / oxalic acid		1/1	1/1
Perchloräthylen / perchloroethylene		4/4	4/4
Perchlorsäure / perchloric acid		2/4	2/4
Petroleum / petroleum	techn. rein / technically pure	1/3	1/3
Phenol / phenol	100 %	2/3	1/2
Phenylhydrazin / phenylhydrazine	techn. rein / technically pure	3/0	3/4

Chemikalie / Chemical	Konzentration / Concentration	HDPE	PP
Phosphorsäure / phosphoric acid	85 %	1/1	1/2
Propan / propane	gasförmig / gaseous	3/4	2/4
Propylenglykol / propylene glycol		1/1	1/1
Propylenoxid / propylene oxide		1/1	1/2
Pyridin / pyridine		1/3	3/3
Quecksilber / mercury	rein / pure	1/1	1/1
Quecksilberchloride / mercury chloride		1/1	1/1
Resorcin / resorcinol	gesättigt / saturated	1/1	1/1
Salicylaldehyd / salicylic aldehyde		1/1	1/2
Salicylsäure / salicylic acid	gesättigt / saturated	1/1	1/1
Salpetersäure / nitric acid	50 %	2/4	3/4
Salzsäure / hydrochloric acid	20 %	1/1	1/1
Schmieröle / lubricants		1/3	3/0
Schwefeldioxid / sulphur dioxide	feucht / damp	1/1	1/3
Schwefelkohlenstoff / carbon disulfide		4/4	4/4
Schwefelsäure / sulphuric acid	95 %	3/4	3/4
Silberacetat / silver acetate		1/1	1/1
Silbernitrat / silver nitrate		1/1	1/2
Stearinsäure / stearic acid	Kristalle / crystalline	1/3	1/3
Sulfide / sulphides		2/3	(2)
Terpentinöl / turpentine oil		2/2	4/4
Tetrachlorkohlenstoff / carbon tetrachloride		3/4	4/4
Tetrahydrofuran / tetrahydrofuran		3/4	3/4
Thionylchlorid / thionyl chloride	techn. rein / technically pure	4/4	4/4
Trichloräthylen / trichloroethylene	100 %	3/4	4/4
Vinyl / vinyl	techn. rein / technically pure	0/0	(3)
Weichmacher / plasticizer		1/3	1/3

Je Medium sind 2 Werte angegeben, linke Zahl = Wert bei +20°C, rechte Zahl = Wert bei +50°C Temperatur.

1 = sehr gut beständig / geeignet, 2 = gut beständig / geeignet, 3 = bedingt beständig, 4 = unbeständig, 0 = kein Wert vorhanden.

Diese Angaben sind Empfehlungen ohne Gewähr. Ein Rechtsanspruch kann aus den gemachten Angaben nicht abgeleitet werden.

2 values are assigned to each medium, left number = value at +20°C, right number at +50°C temperature.

1 = very resistant / suitable, 2 = reasonably resistant / suitable, 3 = limited resistance, 4 = unsuitable, 0 = no value recorded.

These details represent suggestions and offer no guarantees. Legal claims may not arise due to the information provided.

HDPE Polyethylen hoher Dichte / high density polyethylene, **PP** Polypropylen / polypropylene

Allgemein/Bitte beachten:

Alle im Katalog aufgeführten Maße, Gewichte und technischen Daten sind Richtwerte. Sie stellen keine verbindliche Zusicherung bestimmter Eigenschaften oder die Eignung für bestimmte Verwendungszwecke dar. Technisch bedingte Toleranzen entsprechend den DIN Normen. Änderungen und Irrtümer vorbehalten.

Die Angaben beruhen auf unseren aktuellen technischen Kenntnissen und Erfahrungen. Wegen der Fülle möglicher äußerer Einflüsse in der Anwendung der Produkte, die außerhalb unserer Kontrolle liegen, befreien sie den Anwender nicht von eigenen Prüfungen und Versuchen.

General/Please note:

All dimensions, weights and technical data listed in the catalog are approximate values. It is not necessary that these specifications guarantee specific features or are suitable for a certain application. Tolerances based on technical specifications according to DIN standards. Amendments and corrections are subject to change.

The information is based on our current technical know-how and experience. The operator must not be exempt from personally testing and troubleshooting, as there can be numerous possible external influences on the application of the products that are outside of our control.

Eine rechtlich verbindliche Zusicherung bestimmter Eigenschaften sowie die Eignung für einen konkreten Einsatzzweck kann weder ausdrücklich noch stillschweigend abgeleitet werden.

Schutzrechte sind gegebenenfalls zu beachten.

There can be no explicit or implicit inference of a legally binding assertion of specific features and suitability for a certain application.

Industrial rights must be observed, if applicable.

Weitere WERIT Produktprospekte

Industrieverpackung

Kunststoffpaletten

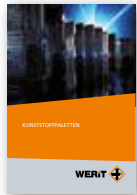

IBC
(Intermediate
Bulk Container)



Industrietanks



Haustechnik

Heizöltanks
Elektro
Sanitär

Spezialprodukte

Schrauben und Muttern
Haus- und Gartenartikel

...mehr Informationen unter www.werit.eu

Further WERIT Product Brochures

Industrial Packaging

Plastic Pallets

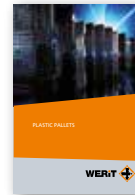

IBC
(Intermediate
Bulk Container)



Industrial Tanks



Haustechnik

Heating Oil Tanks
Electrical
Sanitary

Special Products

Screws and Nuts
House and Garden Products

...further information can be found on www.werit.eu



www.werit.eu

D-57610 Altenkirchen	Kölner Straße	Phone +49 (0) 2681 807-01	Fax +49 (0) 2681 807-200	altenkirchen@werit.eu
D-53567 Buchholz	Industriepark Nord 27	Phone +49 (0) 2683 976-0	Fax +49 (0) 2683 6465	buchholz@werit.eu
D-01458 Ottendorf-Okrilla	Geldroper Straße 5-11	Phone +49 (0) 35205 5530	Fax +49 (0) 35205 55443	ottendorf@werit.eu
A-6700 Bludenz	Austraße 61	Phone +43 (0) 5552 63315-0	Fax +43 (0) 5552 63315-33	office@werit.at
CH-8105 Regensdorf/Zürich	Wehntalerstrasse 113	Phone +41 (0) 44 843 50 50	Fax +41 (0) 44 843 50 59	info@werit.ch
F-67160 Wissembourg	7, Rue de l'Industrie	Phone +33 (0) 3 88 54 10 20	Fax +33 (0) 3 88 54 29 28	info@werit.fr
F-26200 Montélimar	Allée du Lac	Phone +33 (0) 4 75 54 20 20	Fax +33 (0) 4 75 54 20 09	info@werit.fr
E-08403 Granollers/Barcelona	Avda. San Julian 125/127	Phone +34 938 402256	Fax +34 938 402198	info@werit.es
GB-Manchester	Darby Road, Irlam, M44 5BP	Phone +44 (0) 161 776-1414	Fax +44 (0) 161 776-1515	manchester@werit.eu
PL-50-513 Wrocław	ul. Gazowa 24/25	Phone +48 (0) 71 3362595	Fax +48 (0) 71 3336500	werit@werit.pl