

# IMPULSE® G+ & VG+ Series 4

Adjustable Frequency Crane Controls

## THE NEXT GENERATION OF CRANE PERFORMANCE



**MAGNETEK**  
MATERIAL HANDLING

**IMPULSE**•G+&VG+  
Series 4

Adjustable Frequency Crane Controls

# THE NEXT GENERATION OF CRANE PERFORMANCE

Magnetek's IMPULSE®•G+ and VG+ Series 4 drives continue our tradition of providing the most reliable and cost-effective adjustable frequency crane controls available. Industry-leading safety and performance features combine with our superior application expertise to provide unmatched performance for your material handling system.



# SERIES 4 VARIABLE FREQUENCY DRIVES

**LOAD CHECK II™** continuously detects hoist overload conditions, halting upward motion and only allowing the load to be lowered. Load Check II continuously monitors the hook load, both during acceleration and constant speed, eliminating the need for load cells in most applications. It provides an auto-setup function which defines the hoist's maximum hook load in seconds. With these control advancements, the drive no longer pauses for tests unless rated capacity is approached, providing increased productivity.

**SAFE TORQUE OFF** provides a redundant hardware safety circuit that guarantees motor and brake power are removed when an E-STOP switch or safety controller opens the drive input, eliminating the need for external disconnects. This functionality is provided in a safety category 3 architecture and designed to PLd and SIL CL2 according to ISO/EN 13849-1 and IEC/EN 62061 respectively, meeting the requirements of IEC/EN 61508.

**ADAPTIVE ULTRA-LIFT™** allows for hoist operation above base speed with a light load or empty hook. Adaptive Ultra-Lift continuously monitors motor torque and adjusts motor speed to operate at peak performance, improving plant safety and maximizing throughput. For example, motor speed can now be increased automatically when a magnet releases a load or gear ratios change with overwrapping drums.

**BRAKE TEST** verifies brake torque with the press of a button, capturing breakaway torque with a monitor parameter on the keypad. This valuable tool determines the condition of the brake so you can perform preventative maintenance and quickly commission the crane.

**ANTI-SHOCK** automatically stabilizes loads by detecting and minimizing rapid increases in motor torque, thus reducing the potential for crane damage caused by operator induced load shock.

**QUICK-SET™** parameter group makes drive setup even easier. The drive populates a single menu with the most frequently used parameters based on the motion and speed reference selected. For example, when a 3-step traverse drive is configured, the three speed reference, two acceleration-deceleration, programmable input, motor FLA, and Reverse Plug Simulation™ parameters are all added to a convenient, single menu.

**OPTION CARDS** provide the drive flexibility needed with expandable AC, DC digital and analog input and output option cards. Simplify automation and diagnostics integration with our EtherNet/IP, Modbus TCP/IP, PROFIBUS-DP, and PROFINET option cards. The new control power supply option maintains drive diagnostics, I/O, and communications when main power is disconnected from the drive.

**IMPULSE•LINK 4.1 BASIC AND WIRELESS DIAGNOSTICS SYSTEMS (WDS)** maximize the efficiency of your drive by providing easy parameter management right on your PC. WDS can communicate with up to 31 drives remotely, allowing wireless drive diagnostics, monitoring, and programming.

**RELIABILITY** Magnetek drives are designed with reliability and economy in mind. The hardware and software were designed and extensively tested specifically for the operating conditions seen in overhead material handling applications. These durable drives feature new power modules that can withstand four times more thermal cycles than previous generations. Preventative maintenance monitors provide the feedback you need to proactively schedule maintenance and minimize downtime. IMPULSE•G+ & VG+ Series 4 drives are backed by our industry-leading three-year warranty.

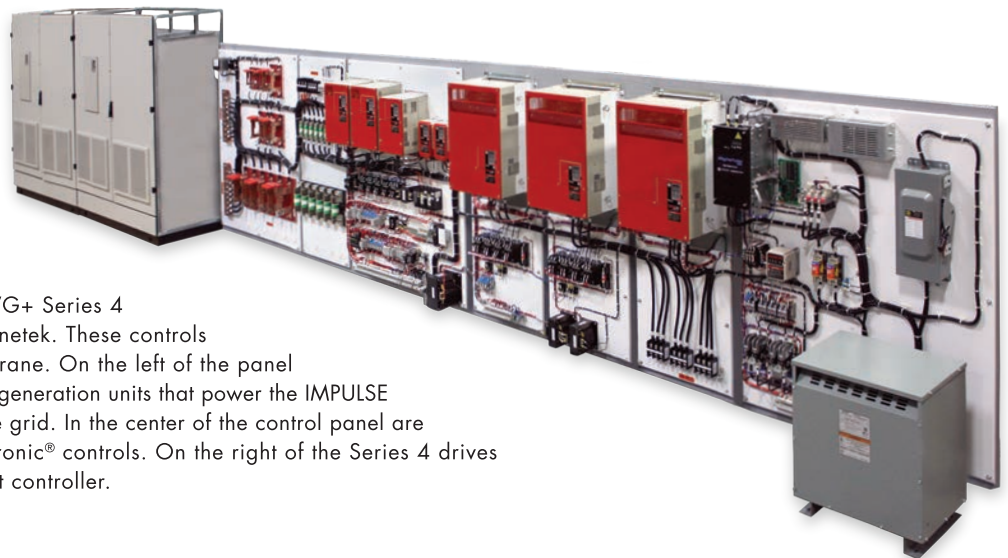

Pictured is a common bus IMPULSE•G+ & VG+ Series 4 engineered control panel designed by Magnetek. These controls are installed on a cab operated hot metal crane. On the left of the panel are two IMPULSE•D+ HHP active front-end regeneration units that power the IMPULSE drives and regenerate AC power back to the grid. In the center of the control panel are our IMPULSE•G+ & VG+ drives and Braketronic® controls. On the right of the Series 4 drives is our MagnePulse™ DMC solid-state magnet controller.



## CUSTOM CONTROL PANELS

Magnetek's custom control panels with IMPULSE•G+ and VG+ Series 4 drives provide the ultimate solution for overhead material handling. These panels are custom designed and built to your specifications to meet your exact application requirements. Our experienced engineering staff provides technical support and extensive overhead material handling expertise when quoting and designing your project. Custom panels are available with an unlimited number of configurations, components, and accessories.

### COMMON OPTIONS INCLUDE:

- 120V control transformer and interface card
- Brake contactor
- Built-in electronic motor thermal overload protection
- Clearly marked wires (at both ends)
- Wiring diagram
- NEMA 4/12 enclosure
- Enclosures for caustic and other environments
- Wiring for radio remote controls
- NEMA brake contactors
- Load and line reactors
- Air-conditioning or cooling fans
- Heaters and thermostats
- Door mounted keypads
- UL 508 certification

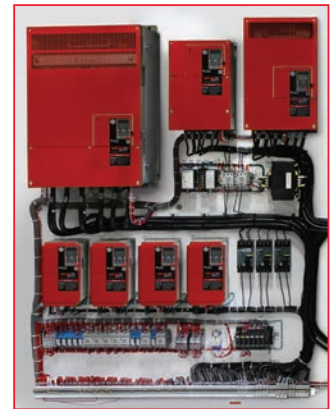

**We can design a system to fit your application. Contact the factory for information.**

## KEYPAD WITH DIGITAL DISPLAY

Our user-friendly keypad gives you five lines of 16 characters each and includes soft keys and upgraded parameter selection. The display makes navigation and reading diagnostics even easier.

### ALLOWS FOR:

- Programming various drive parameters
- Parameter back-up (store and copy)
- Monitoring functions of the drive
- Reading of alpha-numeric fault diagnostic instructions
- Remote monitoring



## FEATURES

## BENEFITS

# SAFETY

Brake Test*	Allows testing of available brake torque
Anti-Shock*	Minimizes harmful torque increases due to load shock, reducing potential for equipment damage
Encoder Loss Detection*	Signal loss detection at all times, even when the motor is not rotating (load float)
Snapped Shaft Detection*	Detects a broken coupling shaft or discontinuity in the drive train
Roll Back Detection/Torque Proving at Start/Brake Check at Stop*	Drive monitors brake functionality and motor torque at start and stop; the drive will maintain control of the load in case of a brake failure
Safe Operating Windows	Reduces the possibility of programming unsafe parameters
Load Check II™	Continuously detects hoist overload conditions
Quick Stop™	Reduces the possibility of load and crane collision
Slack Cable Detection	Provides annunciation of the slack cable condition to the operator
Multi-Level Password Protection	Limits unauthorized modification of drive parameters
Phase Loss Detection	In case of output phase loss, brake will set immediately, retaining load
Control Interface	Optically isolated quick disconnect 120 VAC control interface with parameter backup
UL/cUL Rated	Tested and listed by Underwriters Laboratory
Safe Torque Off	Redundant crane monitoring circuits can externally stop the drive to safety category 3
Ground Fault Short Circuit Protection	Reduces damage to motor and drive
DC BUS Charge Indicator	Indicates when the DC BUS has discharged to a safe level

# PERFORMANCE

Indexing*	Allows precise, programmed motor movement
Load Sharing*	Allows two or more mechanically coupled motors to be controlled in a master/slave torque control fashion
Hook Height Measurement*	Uses an incremental encoder signal to determine hook height from a calibrated position
Electronic Programmable Limit Switch*	Allows slow down and stop limits without a geared limit switch
Automatic Reset	Allows selectable conditions to be automatically reset with a new run command
Over-Torque/Under-Torque Detection	Allows programmable outputs and actions based on torque conditions
Slip Compensation	Automatically compensates for motor slip
Motor Lead Reversal	Electronically swaps motor leads for reverse operation
Keypad Copy	Copy, store, and write parameters to/from keypad
Communication	Built-in RS-485 communication (Modbus - RTU)
Static Auto-Tune	Allows auto-tune without mechanical disconnection
Enhanced Keypad Display	Easily navigate and read diagnostics
Load Float™**	Allows a load to be held aloft at zero speed without setting the electric brake
Weight Calculation*	Enables load weight to be calculated with an accuracy of $\pm 5\%$ of full load (0–10 VDC Output)
X-Press Programming™	Allows programming initial setup in seconds
Swift-Lift™/Ultra-Lift™	Allows overspeeding with light loads or empty hook
Reverse Plug Simulation™	Allows operator to smoothly and quickly stop and change directions without setting parking brake
Stall Prevention	Extends acceleration time and prevents the motor torque limits from being exceeded
Micro-Speed™	Allows operator to make precise, slow movements
Multi-Function Input Terminals	Set end of travel/slow down limits or other functions
Flash Memory	Stores last ten fault occurrences, even after power-down, for diagnostic purposes
Elapsed Time Counter	Indicates actual time of operation (power on or run time)

# RELIABILITY

Preventative Maintenance Monitors	Perform drive maintenance before a failure to minimize downtime
Programmable Fan	Cooling fan on/off control selections for longer life
Ambient Compensated Overload	High ambient motor protection
Increased Drive Output Current Ratings	Designed for 2x longer life than previous models including 4x longer power module life
Built-in Auto-Tune	Maximizes performance and minimizes power lesage through (static or rotational) auto-tuning to extend motor life
Communications	Provides reliable digital link among various crane system peripherals, including Modbus RTU, PROFIBUS-DP, PROFINET, and Ethernet/IP, Modbus TCP/IP
Operation/Fault Display	Simplifies setup and troubleshooting

\* Features available on VG+ only



# SPECIFICATION VALUE AND INFORMATION

Certification	UL, cUL, CSA, RoHS (CE available upon request)
Rated input power supply volts and frequency	3-phase 200–240 VAC, 380–480 VAC, or 500-600 VAC; 50 or 60Hz
Allowable input voltage fluctuation	+10% or -15% of nominal, 3-phase
Allowable input frequency fluctuation	±5% of nominal
Control method	Fully digital; sine-wave, V/F control, open loop vector control, flux vector control
Maximum output voltage (VAC)	Max output voltage 3-phase, 200/208/230/240/380/400/415/440/460/480/500/575/600V (proportional to input voltage)
Rated output frequency (Hz)	0 to 150 Hz (consult factory for applications above 150 Hz)
Output frequency accuracy	0.01% with digital reference command, -10° to 40°C; 0.1% with analog reference command; 10 bits/10V; 25°C, ±10°C
Frequency reference resolution	Digital: 0.0Hz; analog: 0.03Hz (at 60Hz)
Output frequency resolution	0.0Hz
Overload capacity	150% of rated load for 1 minute
Remote frequency reference sources	0–10 VDC (20Ω); 4–20mA (250Ω); ±10 VDC; serial (RS-485)
Acceleration/deceleration times	0.1 to 25.5sec — 4 sets; all independently adjustable
Braking torque	150% or more with dynamic braking (optional)
Motor overload protection	Electronic thermal overload relay; UL recognized (I2T)
Overcurrent protection level (OC)	200% of rated current
Circuit protection	Ground fault and blown-fuse protection
Overvoltage protection level	410 VDC (230V), 820 VDC (460V), 1040 VDC (575V)
Undervoltage protection level	190 VDC (230V), 380 VDC (460V), 475 VDC (575V)
Heatsink over temperature	Thermostat trips between 115-145°C
Four quadrant torque limit selection	Separate functions for FORWARD, REVERSE, and REGEN; all selectable from 0–300%
Stall prevention	Separate functions for acceleration, at-speed and constant horsepower regen
Other protection features	Speed deviation, overspeed, mechanical brake failure, lost output phase, lost input phase, failed-oscillator, PG-disconnect, mechanical overload, roll-back detection, internal braking transistor failure, and built-in watchdog
DC bus voltage indication	Charge LED is on until DC bus voltage drops below 50VDC
Location	Indoors; requires protection from moisture, corrosive gases and liquids
Ambient operating temperature	14° to 140°F (-10° to 60°C). Consult factory for high ambient applications
Storage temperature	-4° to 158°F (-20° to 70°C)
Humidity	95% relative; noncondensing
Vibration	1G for 10-20Hz 0.6G for 20-55Hz (2003-2180, 4001-4150, 5001-5077) 0.2G for 20-55Hz (2215-2415, 4180-41090, 5099-5200)
Elevation	3300 ft. (1000 m) or less 9900 ft. (3000 m) or less with current derating
Safety standard	UL 508C

# CAPABILITIES

## IMPULSE•G+ SERIES 4

### RATINGS

200-240 VAC, 3.0 to 415A (0.75 to 150 HP)  
380-480 VAC, 1.8 to 1090A (0.75 to 900 HP)  
500-600 VAC, 1.7 to 200A (1 to 200 HP)

### CLASS OF SERVICE

CMAA Class A-F Service  
AISE TR6 Class 1 to 4  
ASME HST-4M H1 to H5

### SPEED RANGE

40:1 in V/F Mode (15 preset V/F Patterns, 1 Adjustable)  
200:1 in Open Loop Vector Mode

### SPEED CONTROL METHODS

Up to 17 Distinct Speeds (Stepped)  
2-Step Infinitely Variable  
3-Step Infinitely Variable  
Analog Signal (0-10 VDC, 4-20mA,  $\pm 10$  VDC)  
Digital Pulse Train Input (32kHz max)  
Radio Drive Serial Interface (RDSI)

### PROGRAMMABLE TERMINALS

(8) 120 VAC Inputs (24 VAC, 48 VAC, or 24 VDC optional)  
(3) Digital Dry Contact Relay Outputs (1A max @ 250 VAC, 1A max @ 30 VDC, Form A)  
(1) Dedicated Fault Relay Output (1A max @ 250 VAC, 1A max @ 30 VDC, Form C)  
(3) Analog Inputs (0-10 VDC and  $\pm 10$  VDC (20K  $\Omega$ ), 4-20mA (250  $\Omega$ ))  
(2) Analog Outputs (0-10 VDC and  $\pm 10$  VDC max current 2mA, 4-20mA (500  $\Omega$ ))  
(Consult factory for additional analog/digital input/output option cards)

### APPLICATIONS

Worm Gear and Mechanical Load Brake Hoists  
Traverse Motions

## IMPULSE•VG+ SERIES 4

### RATINGS

200-240 VAC, 3.0 to 415A (0.75 to 150 HP)  
380-480 VAC, 1.8 to 1090A (0.75 to 900 HP)  
500-600 VAC, 1.7 to 200A (1 to 200 HP)

### CLASS OF SERVICE

CMAA Class A-F Service  
AISE TR6 Class 1 to 4  
ASME HST-4M H1 to H5

### SPEED RANGE

1500:1 in Flux Vector Mode

### SPEED CONTROL METHODS

Up to 17 Distinct Speeds (Stepped)  
2-Step Infinitely Variable  
3-Step Infinitely Variable  
Analog Signal (0-10 VDC, 4-20mA,  $\pm 10$  VDC)  
Digital Pulse Train Input/Output (32kHz max)  
Radio Drive Serial Interface (RDSI)

### PROGRAMMABLE TERMINALS

(8) 120 VAC Inputs (24 VAC, 48 VAC, or 24 VDC optional)  
(3) Digital Dry Contact Relay Outputs (1A max @ 250 VAC, 1A max @ 30 VDC, Form A)  
(1) Dedicated Fault Relay output (1A max @ 250 VAC, 1A max @ 30 VDC, Form C)  
(3) Analog Inputs (0-10 VDC and  $\pm 10$  VDC (20K  $\Omega$ ), 4-20mA (250  $\Omega$ ))  
(2) Analog Outputs (0-10 VDC and  $\pm 10$  VDC max current 2mA, 4-20mA (500  $\Omega$ ))  
(1) Single line driver/open collector encoder option card with 5/12 VDC (200mA) power supply  
(Consult factory for additional analog/digital input/output option cards)

### APPLICATIONS

Non-Mechanical Load Brake Hoists  
Traverse Motions (Consult factory)



## ACCESSORIES

### INTERFACE CARD

This provides an optically-isolated interface of 8 digital inputs (binary), 3 Form A dry contact digital outputs, 1 Form C dry contact fault output, 3 analog inputs, 2 analog outputs, pulse input and feedback, and RS-485 Modbus RTU interface.

#### DIGITAL INPUT OPTIONS

120 VAC/60Hz  
48 VAC/60Hz  
24 VAC/60Hz  
120 VAC/50Hz  
24 VDC

### INPUT/OUTPUT OPTIONS

#### ANALOG INPUTS

(13 Bit + Sign) – This provides interface of 3 high resolution analog inputs to the drive. Signal levels (individually selectable): 0 to +/- 10 VDC (20kOhm) or 4 to 20mA (500 Ohm). Input resolution: Voltage (1/8192), Current (1/6654).

#### AC DIGITAL INPUTS

(4 Channels) – This provides a optically-isolated interface of 4 digital inputs (binary) to the drive.

#### OPTIONS

120 VAC/60Hz  
48 VAC/60Hz  
24 VAC/60Hz

### INPUT/OUTPUT OPTIONS (CONTINUED)

#### AC DIGITAL INPUTS & OUTPUTS

(4 Channels) – This provides an optically-isolated interface of 4 digital inputs (binary) to the drive and 4 120 VAC, 1A Form A dry contact relay outputs.

#### OPTIONS

120 VAC/60Hz  
48 VAC/60Hz  
24 VAC/60Hz

#### DC DIGITAL INPUTS

(16 Channels) – This provides a 24 VDC optically-isolated interface of 16 digital inputs (binary) to the drive.

#### ANALOG OUTPUTS

(11 Bit + Sign) – This provides 2 signals for remote metering of any two of the drive's "U1" monitors and is additive to the two standard analog outputs. Signal level: 0 to +/- 10 VDC (20kOhm).

#### DIGITAL OUTPUTS

(8 Channels) – This provides 8 additional digital outputs for use in monitoring the status outputs of the drive. Signal levels: 2 channels of Form A, 250 VAC, 30 VDC, 1A and 6 channels of PHC, 48 VDC, 50 mADC, Shared Common.



## CONTROL OPTIONS

### SINGLE ENCODER—LINE DRIVER

This provides velocity and direction feedback from an encoder. This option is used for motor speed feedback in closed loop flux vector control. A 5 VDC buffered output is also included. Signal levels: 5 or 12VDC differential line driver with compliments, maximum input frequency of 300kHz, phases A and B.

### SINGLE ENCODER—OPEN COLLECTOR

This option provides velocity and direction feedback from an encoder and provides motor speed feedback in closed loop flux vector control. A 24 VDC buffered output (open collector) is also included. 32kHz maximum input frequency.

### 24 VDC CONTROL POWER UNIT

24 VDC Control Power Unit—This option provides board-level component voltages for the drives when provided with 24 VDC from an external, customer-supplied source. It is used to maintain both drive control power and network communications (when utilized).

### LCD OPERATOR

The LCD Operator allows the drive to be operated from a remote location up to three meters away.

### SERIES 4 REMOTE OPERATOR KIT

The Series 4 Remote Operator Kit allows the LCD Operator to be mounted to an enclosure door. The kit includes one LCD Operator, one mounting bracket and one RJ-45 cable.

### USB COPY STICK

The USB Copy Stick allows the drive to connect to the USB port on a PC. It can read, copy, and verify drive parameter settings from one drive to another like drive.

USB Copy Unit Kit Contents:

- 1 – USB Copy Unit (Y-Stick)
- 1 – 1 ft. USB Cable to connect PC to Y-Stick
- 1 – 3 ft. Cable with RJ-45 connector on both ends to connect Y-Stick to drive

Driver: USB Copy Stick Driver\*

\*Note: This driver is required to be installed on the PC before the Copy Stick can be used.

## NETWORK COMMUNICATIONS OPTIONS

### ETHERNET/IP

This allows for communication over 10/100Mbps Ethernet networks. This option has the ability to configure the IP address from a user specified IP address, from a DHCP host, or from a BootP host. All parameters, diagnostics, and operational commands are accessible via EtherNet/IP.

### MODBUS TCP/IP

This option complies with the Modbus TCP/IP protocol specification. This allows for Modbus communication over 10/100Mbps Ethernet networks. This option has the ability to configure the IP Address from a user specified IP address, from a DHCP host, or from a BootP host. All parameters, diagnostics, and operational commands are accessible via Modbus TCP/IP. This option supports up to 10 simultaneous PLC/PC connections.

### PROFINET

This option complies to PROFINET I/O device and PROFIDrive profile specifications. It allows connection to a PROFINET network and facilitates the exchange of data via a simple networking solution that reduces the cost and time to wire and install factory automation devices, while providing interchangeability of like components from multiple vendors. This is a PROFINET Conformance Class A certified interface.

### PROFIBUS-DP

This option complies with the Profibus-DP protocol specification. All parameters, diagnostics, and operational commands are accessible via Profibus. The option board provides a 9-pin (F) type D-Sub connector for easily connecting to a standard Profibus-style, shielded twisted-pair cable. Each Profibus network supports up to 99 drives. This option supports all of the Profibus data rates from 9.6Kbps to 12Mbps. The option is configured using parameters within the drive, which allows for easy configuration eliminating the use of hardware switches. Status LEDs are viewable through the front cover, and a monitor has been added to allow for improved diagnostics.



## DRIVE SUPPORT TOOLS

### IMPULSE•LINK 4.1 DIAGNOSTIC SOFTWARE

- Parameter Management
- Drive Monitor
- DataLogger
- Drive Trending Tool

### DATALOGGER SERIES 4

- Easily access Run, Alarm, and Fault histories, drive parameters, and drive trending data
- View data and analysis via the LCD scrolling display or on your PC
- Compatible with IMPULSE® Series 4, Series 3, and G+ Mini drives

## UNSURPASSED PRODUCT SUPPORT

As always, you can count on Magnetek and IMPULSE drives to help you achieve the maximum performance and reliability of your overhead material handling system. Support includes:

- Three-year warranty
- Magnetek Service Technicians on-call 24/7/365
- On-site and in-house product training programs
- Full testing prior to shipment

For maximum control flexibility, match the IMPULSE•G+/VG+ Series 4 with SBI®/SBP2® Pendant Pushbutton Stations or Magnetek's extensive line of Radio Remote Crane Controls.

**For more information, contact Magnetek Material Handling or your local Magnetek Sales Representative.**



# CUSTOM SOFTWARE

Our software will save you money by eliminating the need for a PLC or additional external logic. You will also save time when replacing wire ropes by utilizing the built-in Electronic Programmable Limit Switch function, making rope replacement a quicker and easier task.

FOOTBRAKE/STATIC STEPLESS SIMULATION SOFTWARE

BUCKET CONTROL SOFTWARE

DRIVE SYNCHRONIZATION SOFTWARE

SWAY CONTROL SYSTEM (SCS®) SERIES 2

**These software applications can be added to our already robust IMPULSE drives to meet your unique application requirements.**



## FOOTBRAKE/STATIC STEPLESS SIMULATION SOFTWARE

This software is designed for use on traverse motions to provide an effective means to slow or stop the motion of the bridge or trolley. Encoder feedback is used to determine bridge or trolley speed at all times, allowing the operator to smoothly re-initiate a run command to a coasting crane. This prevents the jerking motions and slow responsiveness found with acceleration and deceleration ramps.

Improved torque control ensures a smooth transition from coasting to slowing down and is non-destructive to the controls or the crane itself. As more torque is applied, the crane will accelerate or decelerate faster. An optional input to the drive while the footbrake is applied prevents the motor from driving into the brake, saving wear and tear.

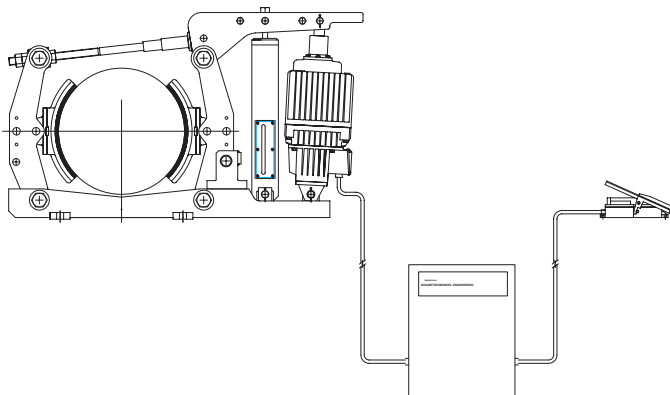

### APPLY THIS SOFTWARE TO:

- New or existing cab controlled cranes
- Existing hydraulic brakes
- Footbrakes
- Static stepless retrofits
- Braketric®

### STATIC STEPLESS SIMULATION SOFTWARE:

- Eliminates current spikes and excess mechanical torque/stress on the drive train and allows quick but smooth starting or changing of direction
- Reduces maintenance costs, with fewer moving parts that wear and require replacing, like contactor tips, brake pads, etc.
- Provides higher reliability with digital technology
- Improves diagnostics and troubleshooting of any fault and alarm conditions with the keypad, fault history, DataLogger, and IMPULSE•Link 4.1 for diagnostics and support tools
- Interfaces to the Induction Master joystick with IVM Board, making a retrofit easy
- Gives operators ultimate control and the same feel to which they are accustomed
- Utilizes standard squirrel cage motor or existing wound rotor



## BUCKET CONTROL SOFTWARE

### SAVE TIME AND MONEY WITH OUR BUCKET CONTROL CUSTOM SOFTWARE APPLICATION

This custom software can be used with IMPULSE•VG+ Series 4 drives to control multi-line clamshell or grapple buckets that utilize a loading/closing hoist. Although the open and hold drives operate independently, the software lets you control the various motions of the bucket without the need for a PLC.

It features Bucket Position Indication, which provides the operator with the open/close status of the bucket while dredging (underwater) or when the bucket is not visible. This is done via analog output from the closing hoist and is received by an analog meter or by an MMI.

No communication (such as master/slave) is needed. In order to maintain the bucket in the open position while lowering, both hoists must operate at the same speed. In order to keep a full bucket closed while raising it out of the pile, torque must be proportionally shared between the two hoists.

**For more information on custom software applications, contact Magnetek Material Handling or your local Magnetek Sales Representative.**

### USE BUCKET CONTROL SOFTWARE\* TO:

- Lower an open bucket
- Close the bucket on a pile
- Raise a closed bucket
- Raise an open bucket
- Perform horizontal winch applications

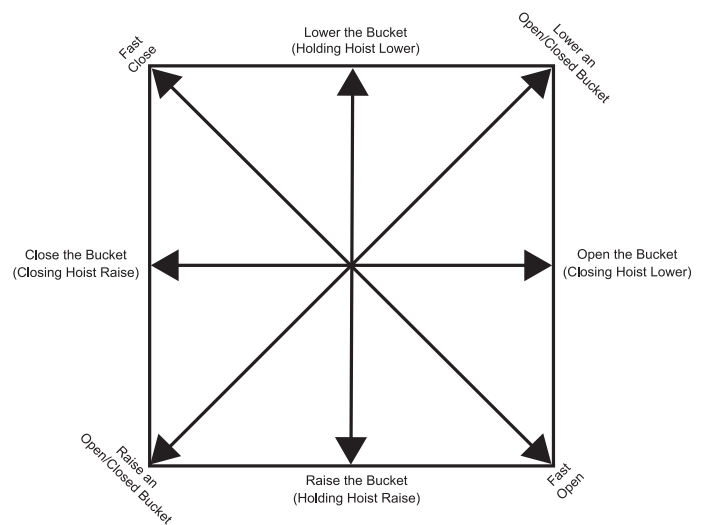

\* Requires a Uni-Polar Analog Master Switch or Multi-Step Digital Speed/Torque References

## DRIVE SYNCHRONIZATION SOFTWARE

### SYNCHRONIZATION SOFTWARE MAKES IT EASY!

This custom software allows you to synchronize multiple IMPULSE•VG+ Series 4 drives. The slave drives utilize an encoder option board with two encoder inputs and monitor both its own encoder feedback AND the master's encoder feedback, while also sending timing status information back to the master. The slave compensates for any position errors by adjusting its motor speed, resulting in near-perfect alignment between the master and slave motor shafts. The slave drive also possesses the ability to automatically re-synchronize the motors and has an electronic gearing feature. While both drives are running, there is no accumulation of position error, so alignment is always maintained.



### YOU CAN:

- Operate a multiple hoist application independently or synchronized
- Synchronize a cable reel to a hoist
- Synchronize multiple trolleys on a single bridge
- Synchronize multiple motions between 2 or more cranes

### DRIVE SYNCHRONIZATION SOFTWARE:

- Offers increased safety by precisely controlling motion and preventing the operator from making an uneven lift
- Saves time and money by eliminating the need for a PLC
- Increases productivity because the operator does not need to level the hoists manually

### DRIVE SYNCHRONIZATION SOFTWARE\* MAY BE APPLIED ON:

- Speed matching - two or more independent systems, such as independent hoists, bridges, or trolleys that are not mechanically linked or bound together
  - System needs to be able to correct error without being mechanically bound (i.e. through the wheels of an end truck)
- Bridge applications where two synchronized motors are driving opposite end trucks (does not automatically compensate for skew)

### PERFORMANCE FEATURES

### BENEFITS

Position error stored at power down

Motions can be automatically re-synchronized even after a power down, without the need for re-homing or calibrating synchronized hook off sets

Multiple gear ratios

Allows motions with different hook speeds, like gearing, and encoder PPRs

Advance/retard function

The user can very easily fine position one or multiple motions

Availability of software features

Standard crane & hoist software features (such as Adaptive Ultra Lift™, Load Check II™, Weight Measurement & more) are available even while utilizing the Drive Synchronization software. Must be specified at the time of order

Drive synchronization software should NOT be applied on:

- Load sharing applications with two or more mechanically coupled systems. This includes directly coupled motor shafts, trolleys, or bridges that are mechanically coupled together or two or more motors that are indirectly tied together through a structure, such as a bridge or trolley.
- Driving two or more wheels on the same rail, such as the swing motion on a log handling crane, or a bridge motion on a polar crane. In these cases, the "Load Share" feature within Magnetek's standard IMPULSE Crane & Hoist software is a better solution.

\*Note: Because customers may not be familiar with programming application specific software of this nature, Magnetek strongly recommends and may in some cases require that the purchaser use Magnetek's Field Service Personnel for initial startup as part of the purchase. Please consult factory for additional information.

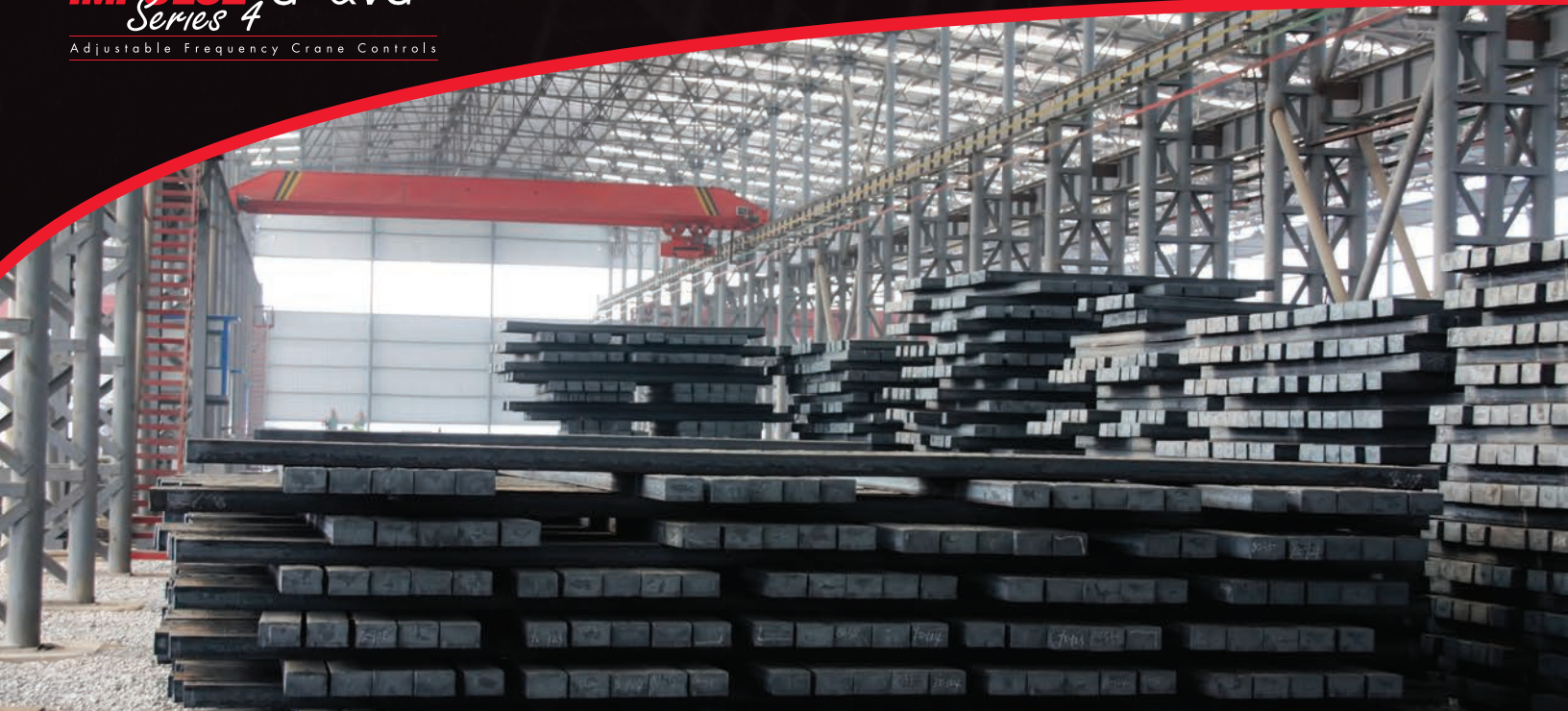

## SWAY CONTROL SYSTEM (SCS®) SERIES 2

### ENHANCE CRANE OPERATION WITH MAGNETEK'S SWAY CONTROL SYSTEM

Leading the way in innovative product development, Magnetek is excited to offer our Sway Control System (SCS) Series 2 to the overhead material handling industry. This custom software is embedded in our IMPULSE•G+ Series 4 variable frequency drives for new or existing crane control systems without the need for external programmable logic controllers or costly height measurement devices.

#### SCS SERIES 2 BENEFITS:

- Improves productivity by allowing the crane operator to concentrate on load engagement/disengagement rather than focusing on minimizing load swing. The system also improves the accuracy of load placement
- Reduces material damage caused by incidental contact of swinging loads
- Enhances safety in operations and reduces the potential for personnel injuries and damage to equipment
- Reduces maintenance costs and downtime by decreasing stresses on structural, mechanical, and control components

#### SCS SERIES 2 HAS BEEN DESIGNED TO:

- Require only one IMPULSE Variable Frequency Drive (VFD) per traverse motion with SCS software. Additional IMPULSE VFDs are connected in a Master/Slave fashion
- Operate in V/f, Open Loop Vector, and Flux Vector control methods
- Be compatible with existing master switch and radio control configurations such as Multi-step and Infinitely Variable Uni-polar/Bi-polar analog
- Eliminate the need for an external programmable logic controller
- Accept a hook height measurement when combined with an IMPULSE•VG+ Series 4 hoist drive
- Eliminate the need for a high maintenance feedback device such as an absolute encoder. The system can also be configured to operate in an operating hook height zone
- Work with multiple hoists on the same bridge

#### PERFORMANCE FEATURES INCLUDE:

- Optional inputs available to fine tune the pendulum length when using multiple below the hook attachments or varying load sizes
- Automatic hook height measurement when combined with an IMPULSE•VG+ Series 4 hoist
- Seamless integration with special functions within IMPULSE variable frequency drives such as Micro-Speed™ and Reverse Plug Simulation™, end of travel slow down, and stop limits
- Enabling or disabling with the flip of a switch

#### System Limitations:

- 300 ft. hoist height maximum

# RELATED PRODUCTS

## ENGINEERED SYSTEMS & SOLUTIONS

Project Evaluation  
Project Management  
Engineering Design  
System Manufacturing and Testing  
Field Startup, Testing, Training and Support  
Customer Training and Maintenance Support  
Application Solutions  
PLC/PC Program Development

## IMPULSE® AC ADJUSTABLE FREQUENCY DRIVES

230, 460, and 575 VAC Power Platforms  
.25–1,500 HP  
Exclusive Application Software  
Specific Crane & Hoist Software

## OMNIPULSE™ DIGITAL DRIVES

DSD – AC in/DC out  
15 – 800 HP  
DDC – DC in/DC out  
5–500 HP  
MagnePulse™ Digital Magnet Control

## VARIABLE SPEED MOTOR CONTROL PANELS

Standard Pre-Engineered Systems  
Custom Engineered Systems

## MOTORS & ACCESSORIES

Standard Inverter Duty AC Induction Motors  
Flux Vector Designed Motors

## POWER DELIVERY SYSTEMS

ELECTROBAR ELITE – 20, 60, 100, 130, 200A  
FABA® Conductor Bar Systems – 100A  
ELECTROBAR HX – 400, 700, 1000A  
ELECTROBAR FS – 90, 110, 125, 250, 400A  
ELECTROBAR® 8-Bar – 90, 110, 250, 350A

## ELECTROMOTIVE™ FESTOONING SYSTEMS

C-Track Festoon  
Heavy Duty I-Beam Festoon  
Mill Duty I-Beam Festoon  
Heavy Duty Aluminum Festoon  
Marine Terminal I-Beam Festoon  
Plug & Play Festoon Components  
Flat Festoon & Round Pendant Cable

## SBI® & SBP2® PENDANT PUSHBUTTON STATIONS

Standard 2– through 12–Button Stations  
Custom Configured Stations

## RADIO REMOTE CONTROL SYSTEMS

Flex VUE®  
Flex EX  
Flex Pro™  
Flex Mini  
*telePendant™*  
*telePilot™*  
Pendant -Style  
MBT  
Mini-MBT  
MLTX™  
MLTX2™  
XLTX  
SLTX™  
Railyard Remote Control Systems

## COLLISION AVOIDANCE SYSTEMS

LaserGuard™2  
ReFlx® 45  
ReFlx® 120

## BRAKES

### 200S INDUSTRIAL SHOE BRAKES

4"–19" Diameter  
9–2,250 Lb. ft. Torque  
AC, DC, Hydraulic Actuators  
AC Explosion Proof Actuators

### 300M AIST MILL DUTY SHOE BRAKES

5"–30" Diameter  
10–11,000 Lb. ft. Torque  
AC, DC, Hydraulic Actuators  
AC Explosion Proof Actuators

### 400D HEAVY DUTY DISC BRAKES

8"–50" Diameter  
50–30,000 Lb. ft. Torque  
AC, DC, Hydraulic Actuators  
AC Explosion Proof Actuators

### BRAKETRONIC® CONTROL SYSTEM

Braketronic Controller  
Standard Pre-engineered Panel  
Mill Duty Foot Pedal (optional)



**MAGNETEK**  
MATERIAL HANDLING

[WWW.MAGNETEKMH.COM](http://WWW.MAGNETEKMH.COM)

[SALES@MAGNETEK.COM](mailto:SALES@MAGNETEK.COM)

N49 W13650 Campbell Drive  
Menomonee Falls, WI 53051  
Toll-Free Phone 800.288.8178  
Toll-Free Fax 800.298.3503  
Phone 262.783.3500  
Fax 262.783.3510

Unit 3 Bedford Business Centre  
Mile Road  
Bedford MK42 9TW UK

4090B Sladeview Crescent  
Mississauga, Ontario, Canada L5L 5Y5  
Toll-Free Phone 800.792.7253  
Phone 905.828.1526  
Fax 905.828.5707

MH400\_Series 4 Brochure  
© Magnetek, Inc. 2015