



# Installation Manual

for RVs IM1



**1600 | 1200 | 600**  
Automatic Charge Control



Thank you for purchasing an EFOY product. We hope that you will enjoy your new unit.

Please read these instructions first before using and always keep them nearby. Be sure to follow all directions in the instructions and in this installation manual.

Should you nevertheless have any questions about installation or operation, please consult your dealer or the EFOY hotline.

SFC Smart Fuel Cell AG  
Eugen-Sänger-Ring 4  
D-85649 Brunnthal-Nord

Hotline: 0049 89 673 592-0 or 00800 732 762 78  
hotline@efoy.eu

[www.efoy.eu](http://www.efoy.eu)

## 1.1 General Instructions

---



Do not open unit or fuel cartridges. Do not use force to open cartridges and do not refill them. Any modifications to the unit may affect safe operation, will lead to a loss of license and will void the guarantee. Use only original EFOY equipment.



Do not store unit and fuel cartridges at temperatures above 45° C. Do not operate at temperatures above 40° C. Keep away from heat and direct sunlight.



Store the unit where there is no danger of freezing, or use the automatic antifreeze feature.



Do not smoke when handling the unit or the fuel cartridges.



Keep away from heat and open flame.

There is a danger of fire if methanol leaks out following an accident, or if the unit or the fuel cartridge has been damaged. Keep away from open fire and make sure area is well ventilated. Small amounts of methanol which may leak out will evaporate without leaving any residue.



Keep unit and fuel cartridges (including empty or partially filled cartridges) out of children's reach.

Operate the unit only in accordance with instructions and keep operating area well ventilated. Do not block exhaust. Avoid inhaling exhaust fumes directly or for prolonged periods of time.

## 1. Introduction



Installation should be carried out by trained personnel only. Wear proper work clothes. Avoid flowing garments and wear a hair net if you have long hair. Clothing and hair can get caught in moving or rotating parts such as in a drill.

Be sure to leave enough space behind the installation area when drilling or cutting out openings. Also be sure to follow the tool manufacturer's safety instructions.

Solvents used in sealants may emit fumes. Make sure that there is sufficient ventilation and follow the instructions for the sealing compound.

Electrical installation work should be done by a licensed electrician only.

All electrical lines must be adequately insulated and protected with proper fuses.

Bare wires and contacts are not permitted.

Use the wire harness (included) to connect the unit.

Check the polarity (see illustration) before connecting the unit.

Both sensor and power lines must always be connected.

Always use separate lines for charging and for voltage metering to the battery. Otherwise, the flow of current will cause false readings.

## 1. Introduction

## 1.2 Tools and Materials

---

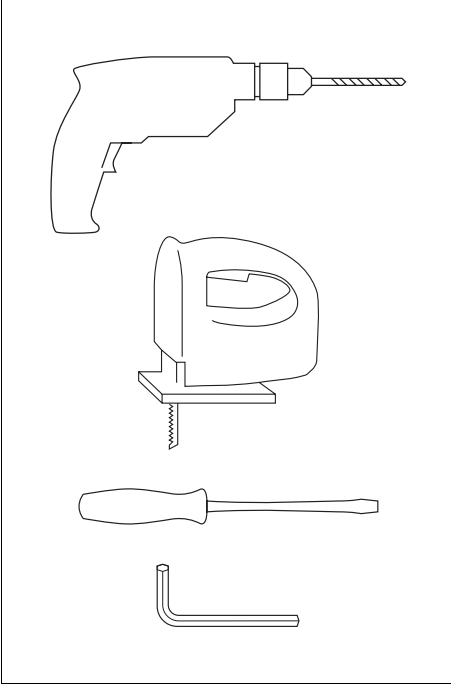

You will need the following tools and sealants to install the fuel cell in an RV:

- electric drill
- jigsaw
- screwdriver
- hexagonal (Allen) wrench
- sealant such as Sikaflex

Use the following screws, depending on the mounting surface (screws are not included):

- 8 screws to attach the mounting plate
- 4 screws to attach the remote control
- 4 screws to attach the fuel-cartridge holder
- cable clamps and fixing screws, if needed

## Table of Content

<b>1. Introduction</b>	<b>4</b>
1.1 General Instructions	4
1.2 Tools and Materials	6
<b>2. Installing the Unit</b>	<b>8</b>
2.1 Standard Equipment	8
2.2 Locations	9
2.3 Notes on choosing a location	9
2.4 Securing the Unit	11
2.5 Off-heat duct	12
2.6 Connecting the Exhaust Hose	14
<b>3. Mounting the Remote Control</b>	<b>15</b>
3.1 Mounting the Remote Control	15
3.2 Connecting the Remote Control	16
<b>4. Electrical Connections</b>	<b>17</b>
4.1 Electrical Connections	17
4.1.1 Connection via the Central Electrical Box (EBL)	18
4.1.2 Connection directly to the battery	20
<b>5. Installing the Fuel Cartridge</b>	<b>22</b>
5.1 Installing the fuel-cartridge holder	22
5.2 Connecting the Fuel Cartridge	23
<b>6. Notes</b>	<b>23</b>

## 2. Installing the Unit

### 2.1 Standard Equipment

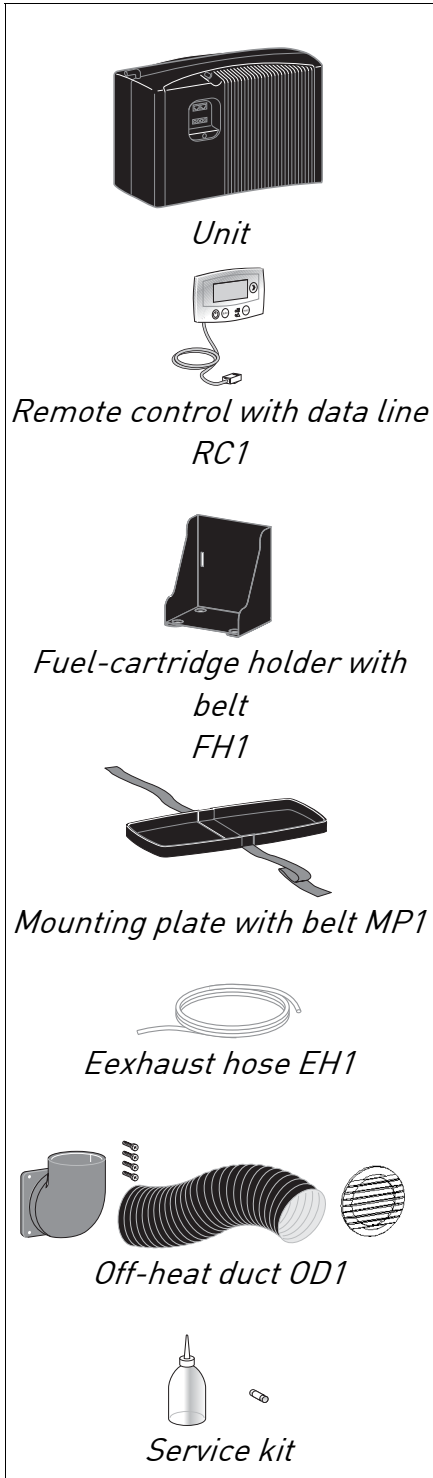

*Standard equipment*

#### Standard Equipment:

- Unit
- Remote control with data line RC1
- Fuel-cartridge holder with belt FH1
- Mounting plate with belt MP1
- Exhaust hose (1.5 m) EH1
- Off-heat duct (consists of off-heat flange, off-heat bow, off-heat tube, orifice and fixing screws) OD1
- Service kit (G-fuse 250V 8A m, 5 x 20 mm and service fluid)
- User manual UM1
- Charge line for RVs CL2

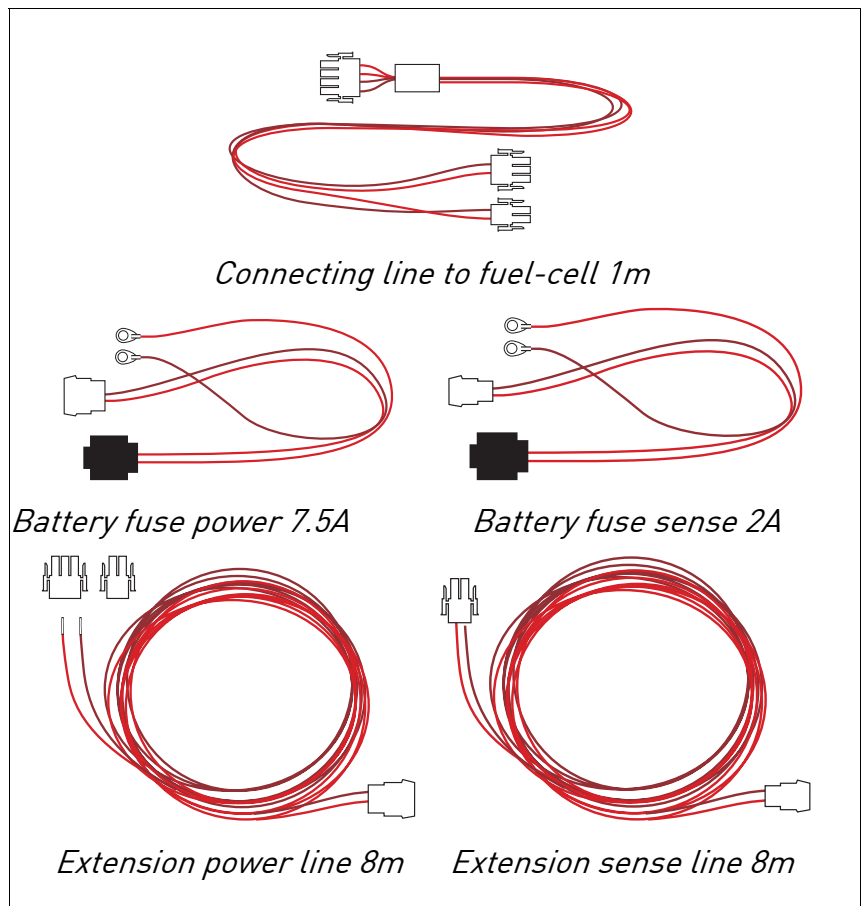

*CL2 charge line for RVs*

## 2. Installing the Unit

### 2.2 Locations

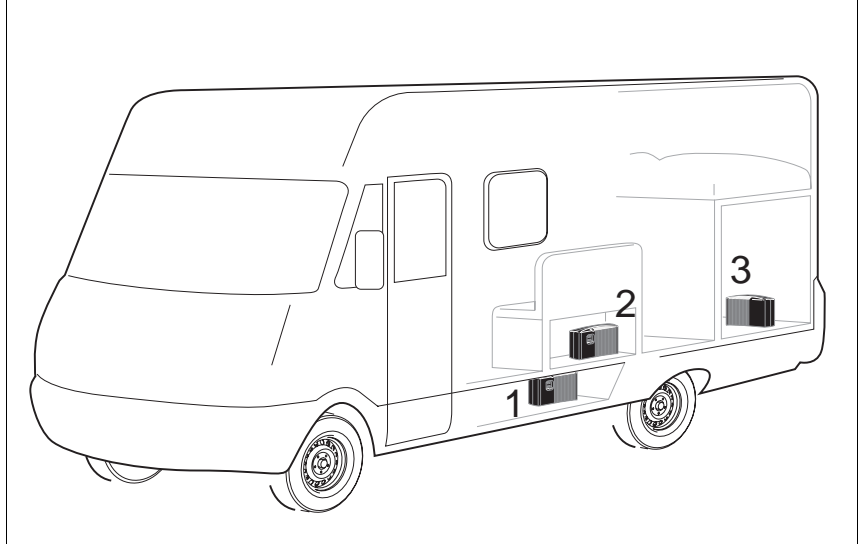

Ideas for installation:

- 1 false floor or side compartment
- 2 seat bench
- 3 rear storage area

### 2.3 Notes on choosing a location

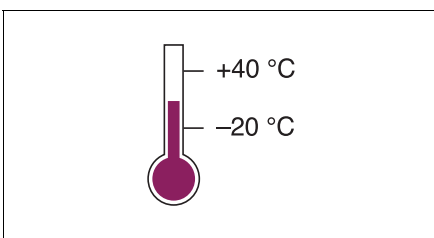

Make sure when choosing a location, that the temperature ranges between  $-20^{\circ}\text{C}$  and  $+40^{\circ}\text{C}$ .



This unit generates heat, thus requiring ventilation. Please take this into account when considering possible locations.

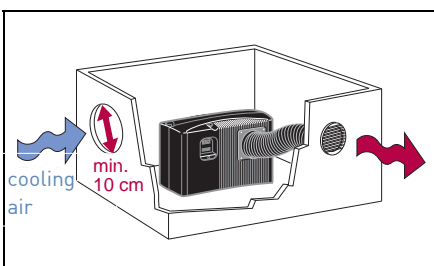

Provide for a vent opening measuring at least 10 cm across when installing. Use the off-heat duct (included) to remove warm air.



## 2. Installing the Unit

Install only in upright position. Use the mounting plate (included).

Make sure that the device does not exceed the maximum inclination.

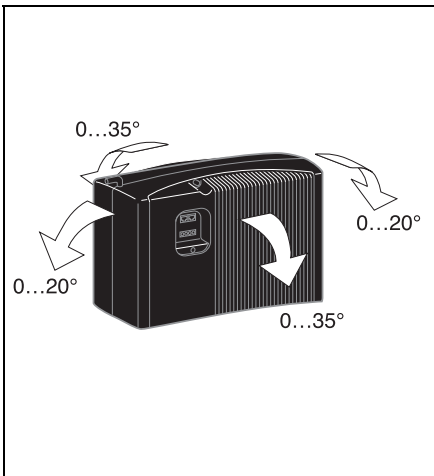

Inclination along the direct axis:  
continual: 35°  
temporary (<10min): 45°

Inclination along the quadrature axis:  
continual: 20°

All electrical connections, the fill opening for service fluid and the fuel cartridge should be easily accessible.

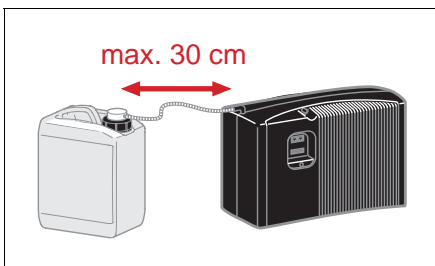

Make sure that the fuel cartridge is located within reach of the connecting hose (30 cm) and that the hose is neither kinked nor crushed.



The fuel-cartridge hose and the exhaust hose may not be damaged. Do not substitute another hose for either of the two.

Use only original-equipment EFOY hoses.

## 2. Installing the Unit

### 2.4 Securing the Unit

---

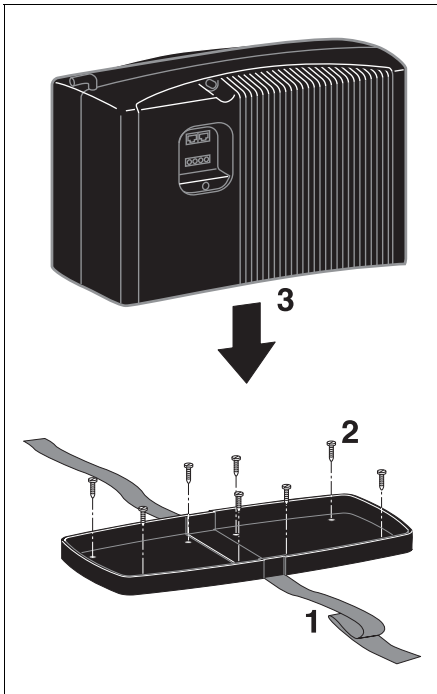

1. Run the belt in the groove under the mounting plate.
2. Secure the mounting plate tightly to the desired location. Use eight proper screws and dowels, if necessary, so that the mounting plate cannot shake loose in case of an accident.
3. Place the unit onto the mounting plate.

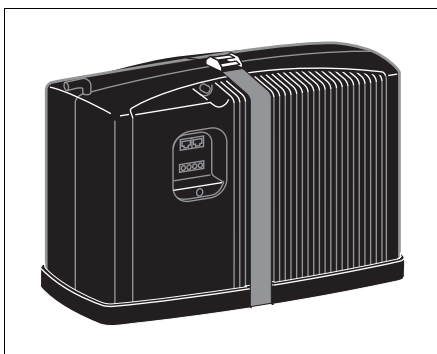

4. Strap the unit tightly to the mounting plate.

## 2. Installing the Unit

### 2.5 Off-heat duct

The off-heat duct (included) extracts warm air so that the unit can also be operated in close quarters.

Use the bow to conduct warm air to the side.

If you do not need the off-heat bow, you can disconnect it from the off-heat flange and connect the off-heat tube directly to the flange.

Make sure that the off-heat tube is not kinked; use a second bow if needed.

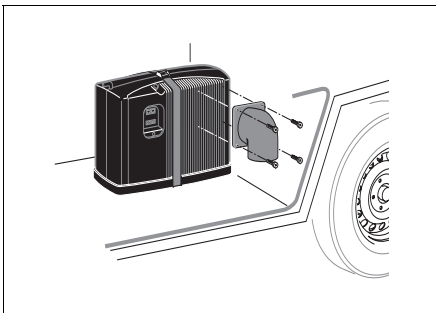
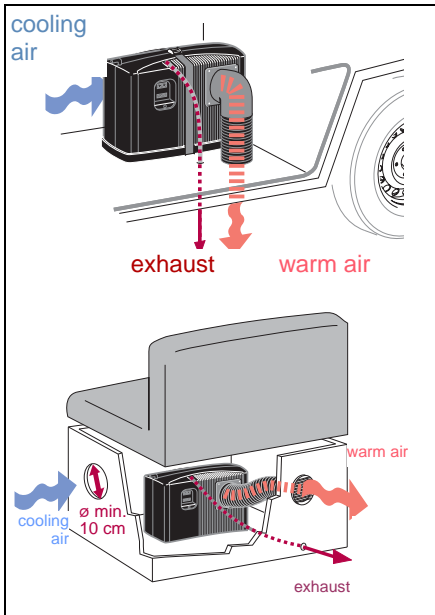

Sink the screws for the off-heat flange into the holes provided.

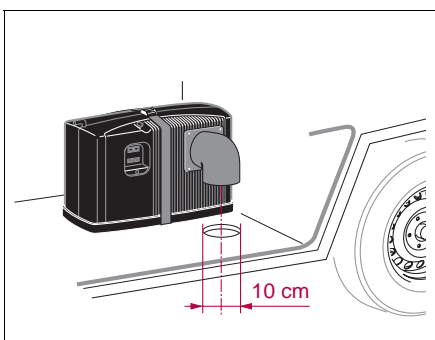

Then pass the off-heat tube to the exterior. You will need an opening with a 100 mm diameter.

Be careful of electrical lines when drilling. The RV manufacturer or your dealer can provide information as to the location of lines.

## 2. Installing the Unit

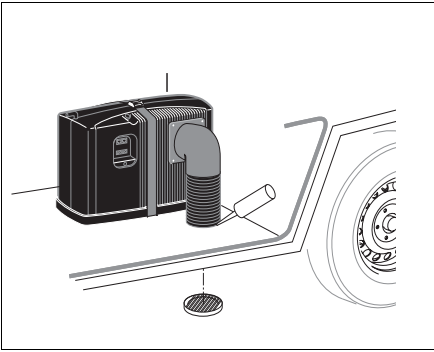

Pass the off-heat tube through the opening; any excess may be shortened.

It may be necessary to use an external face plate to protect the outlet. Use a suitable sealant to prevent moisture from penetrating into the body or into the interior.

## 2. Installing the Unit

### 2.6 Connecting the Exhaust Hose



Exhaust gasses contain moisture and may exceed 60° C, causing scalding. Exhaust byproducts may contain injurious substances. Avoid inhaling exhaust directly or for long periods of time.

The exhaust hose may not be longer than 50 cm in order to prevent freezing in winter. The hose may be up to 150 cm long for summer operation and during transitional seasons.

At no time may siphoning occur in the hose. Make sure that the hose is neither clogged nor blocked.

#### Routing the exhaust hose

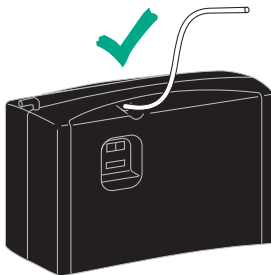

Up

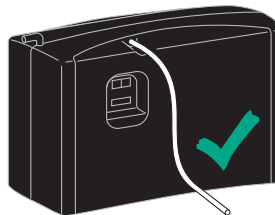

Down

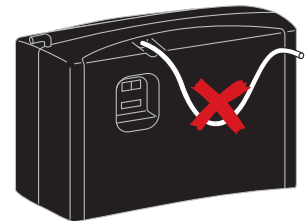

Avoid siphoning

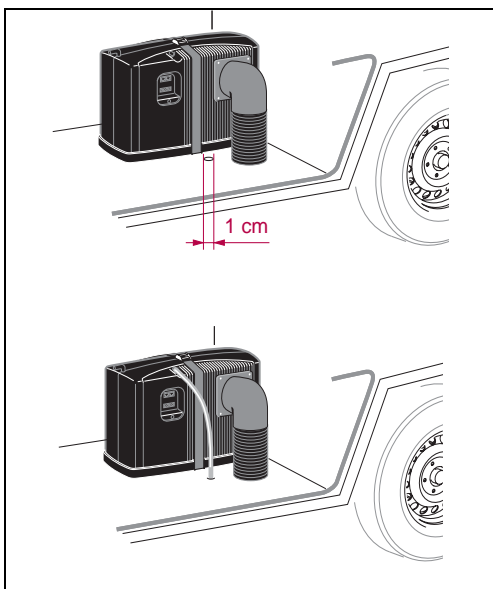

- Remove the cap from the exhaust port. Retain the cap for winter storage or for possible returns.
- Attach the exhaust hose (included) to the exhaust port.
- Route the hose to the exterior and use a suitable sealant to seal the opening. The hose may be shortened as needed. The opening must be 10 mm in diameter.
- Make sure the exhaust hose has no kinks or blockage and that exhaust can escape freely.

### 3. Mounting the Remote Control

## 3.1 Mounting the Remote Control

---

The remote control (1) displays the current status and is used to control the device. Mount the panel where it is easily accessible such as in the cockpit.

If installing the panel flush with the surface of the unit, make sure that there is a sufficient opening for the electronic components behind the opening.

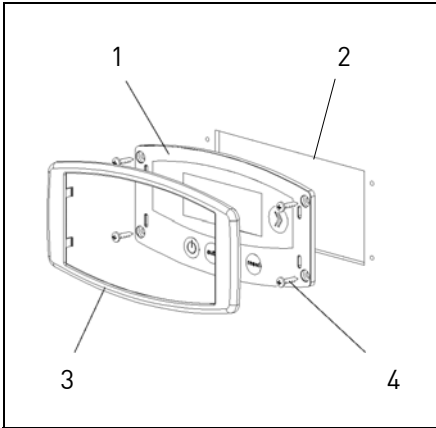

#### Flush mounting:

- 1 remote control
- 2 opening
- 3 frame
- 4 screws

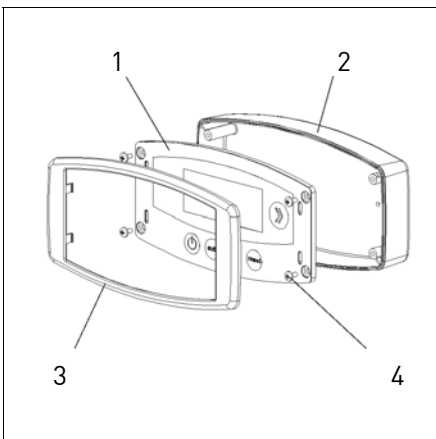

#### Surface mounting:

- 1 remote control
- 2 surface mount
- 3 frame
- 4 screws

#### Surface mounting

Secure the surface mount with two screws.

Connect the remote control with the DL 1 data line (included).

Then secure the control panel (1) with four suitable screws (4) and place the frame (3) over the control panel.

### 3. Mounting the Remote Control

## 3.2 Connecting the Remote Control

---

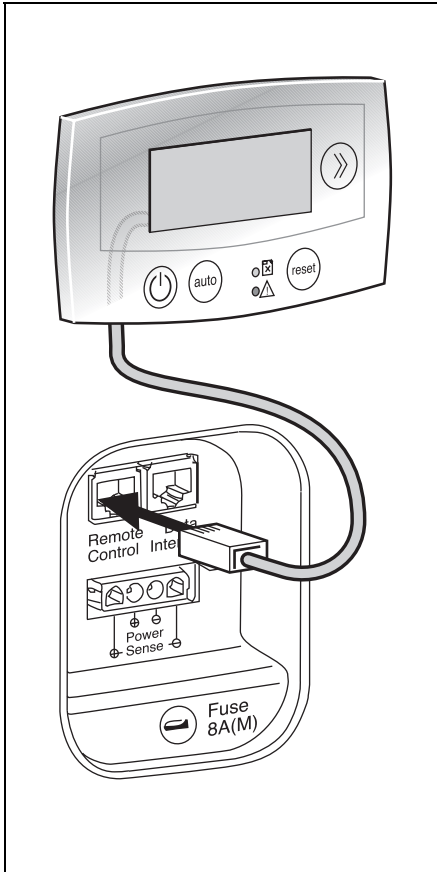

Connect the remote control with the DL data line (included).

If the DL 1 data line is not long enough, you can replace it with a commercially available network line that is longer or shorter (Category 5 patch cable).

Then insert the plug into the left socket on the unit marked "Remote Control".

## 4.1 Electrical Connections



All work should be carried out by qualified technicians in accordance with technical regulations.

Improper connections or the use of wrong gauge wires could result in fire.

All wires must be properly insulated and have adequate voltage rating. All connections must be tight. The use of uninsulated wires and contacts is not permitted.

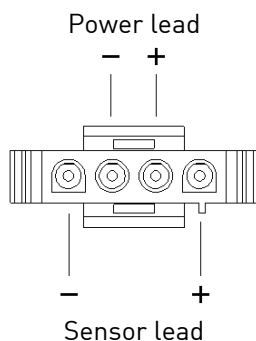
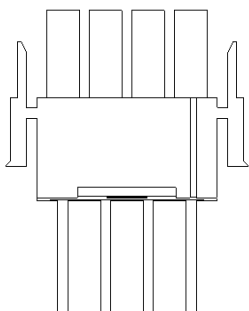

The charging lines consists of four leads that must be connected to the battery as follows:

**Power lead:**

This lead carries current from the fuel cell to the battery.

**Sensor lead:**

This lead measures battery voltage.

To minimize current loss in the leads, the following cross section is recommended, should the battery charging cable be insufficient:

Length [m]	min. cross section
< 5 m	2.5 mm <sup>2</sup>
5 – 10 m	4 mm <sup>2</sup>
10 – 15 m	6 mm <sup>2</sup>

Two kinds of electrical connection are possible:

via the central electrical box (Chapter 4.1.1)

directly to the battery (Chapter 4.1.2)



## 4. Electrical Connections

### 4.1.1 Connection via the Central Electrical Box (EBL)

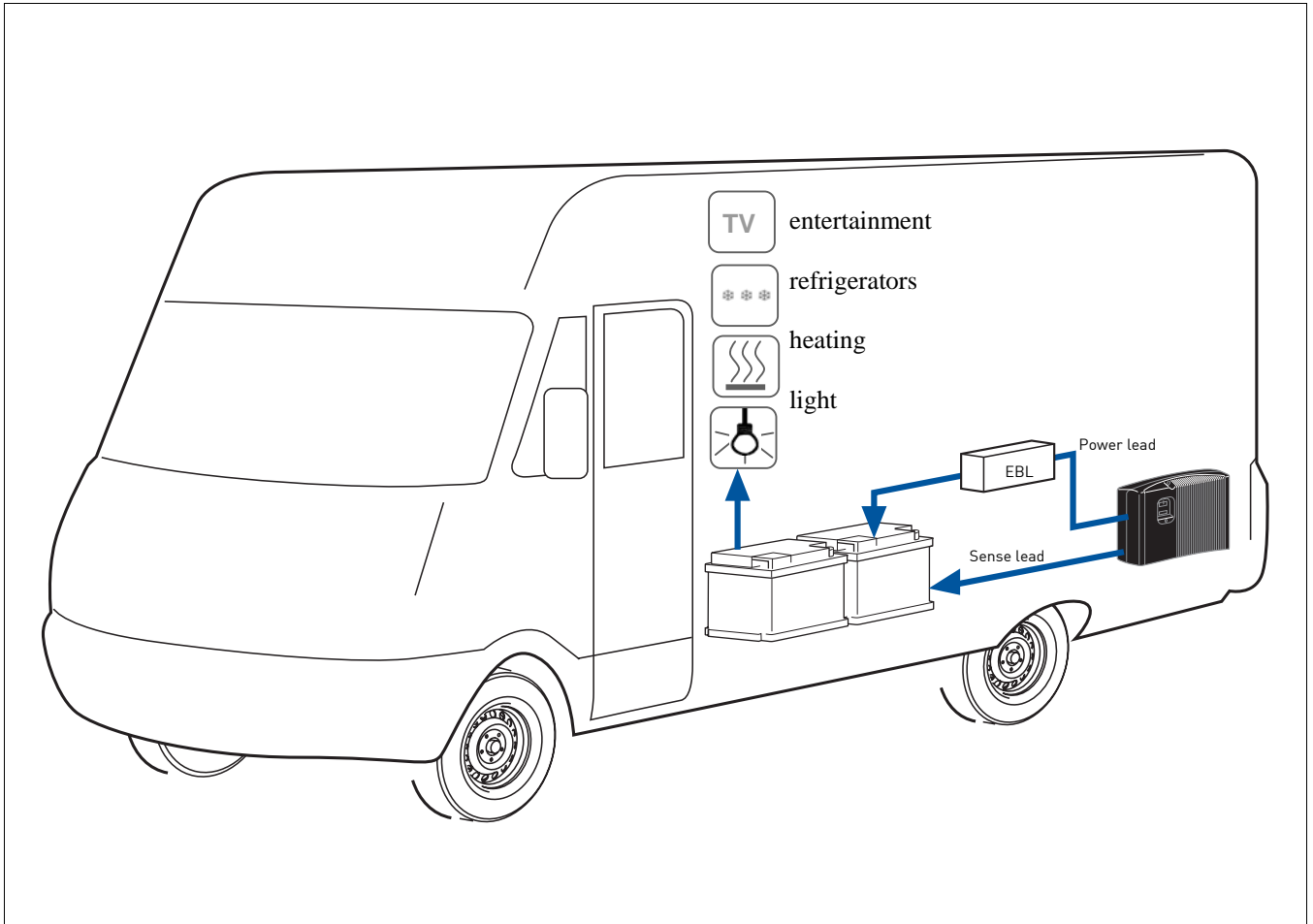

## 4. Electrical Connections

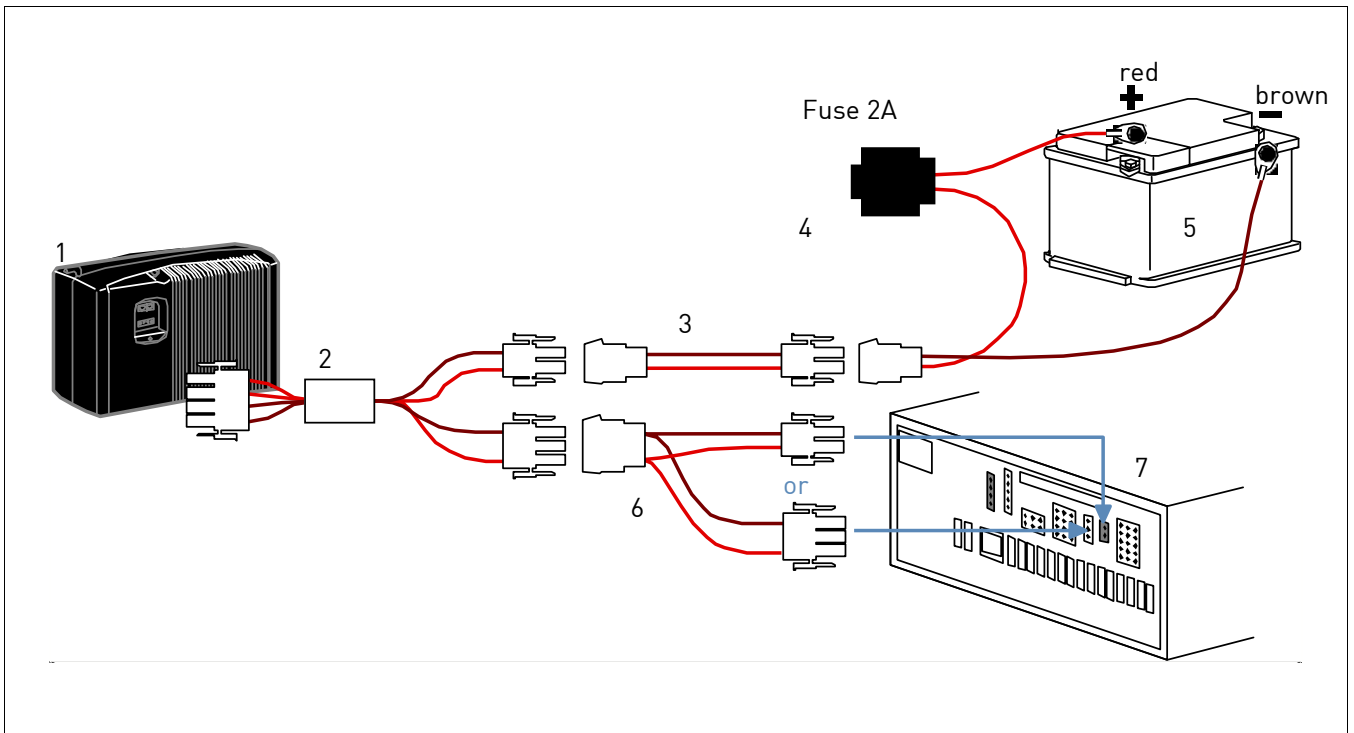

1. unit
2. connecting line to fuel cell
3. extension sense line (optional)
4. battery fuse 2 A
5. battery (a capacity of 40 – 200 Ah is recommended)
6. extension power line with 2- or 3- pole plug (optional)
7. Central electrical box (EBL)

## 4. Electrical Connections

### 4.1.2 Connection directly to the battery

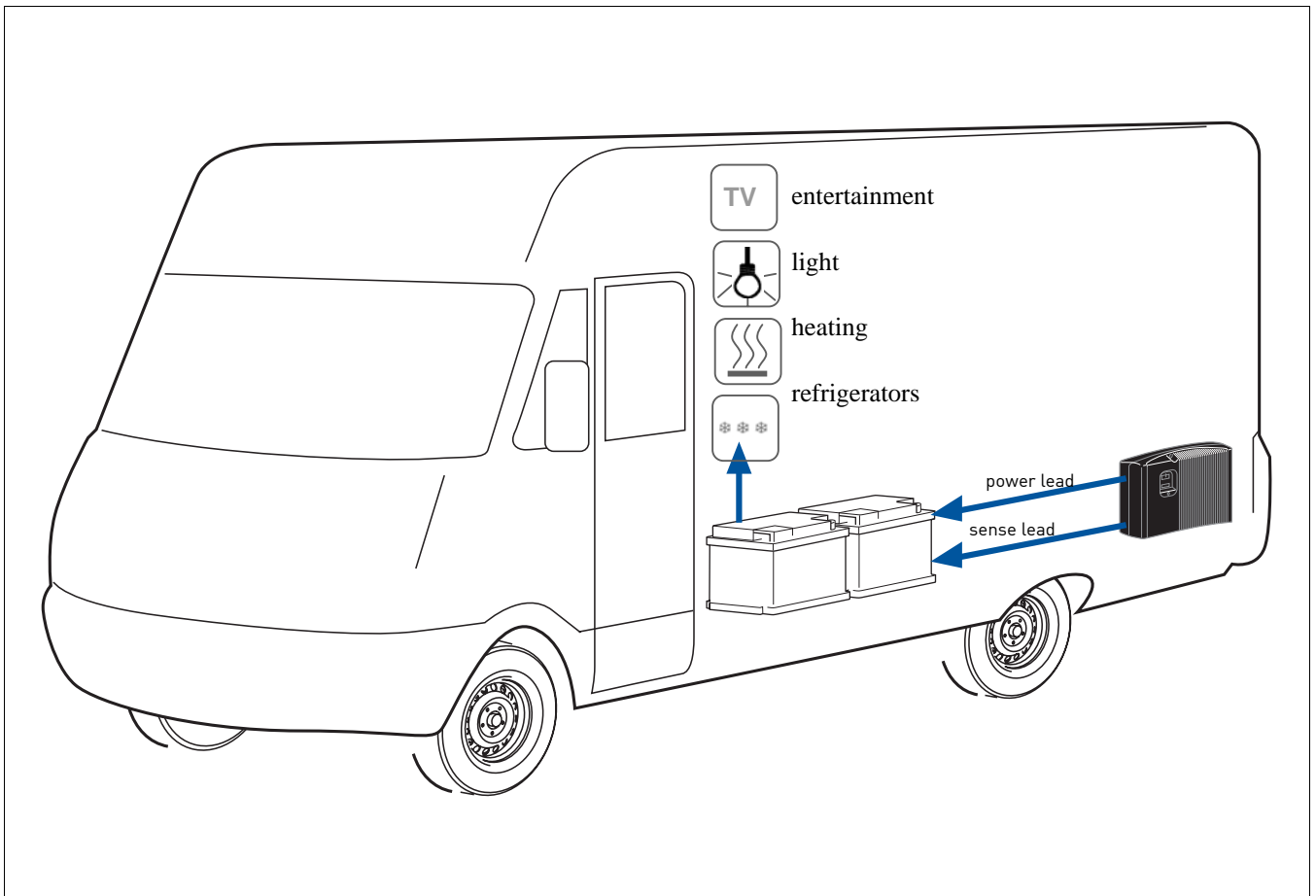

## 4. Electrical Connections

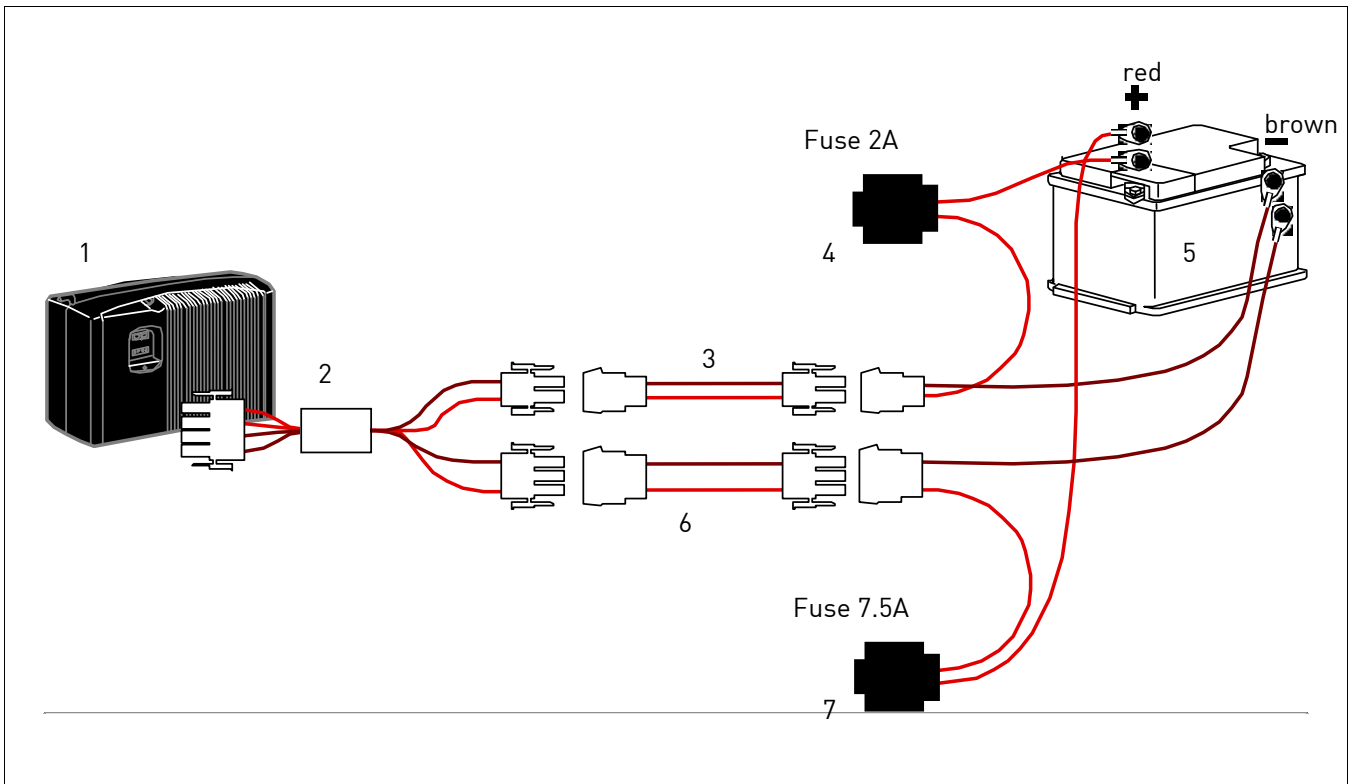

1. unit
2. connecting line to fuel cell
3. extension sense line (optional)
4. battery fuse sense 2 A
5. battery (a capacity of 40 – 200 Ah is recommended)
6. extension power line with 3-pole plug (optional)
7. battery fuse power 7.5 A

## 5. Installing the Fuel Cartridge

### 5.1 Installing the fuel-cartridge holder



Keep fuel cartridge and all reserve cartridges away from children. Keep cartridges away from heat and out of direct sunshine.

Secure fuel cartridge and all reserve cartridges so that they can not shift.

Make sure that the fuel-cartridge connecting hose is neither crushed nor kinked.

Do not place fuel cartridges or reserve cartridges in front of the air intake or outlet!

Place fuel cartridges next to or in front of the unit as illustrated.

Do not place objects such as reserve fuel cartridges in front of the air intake or outlet.

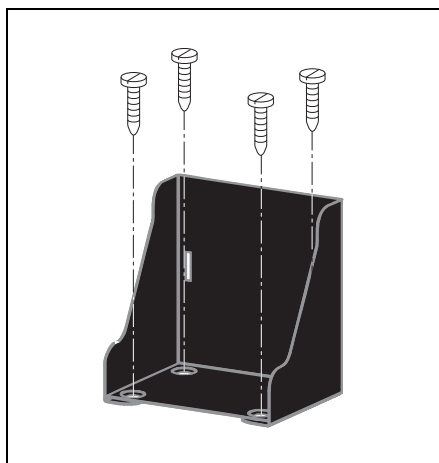
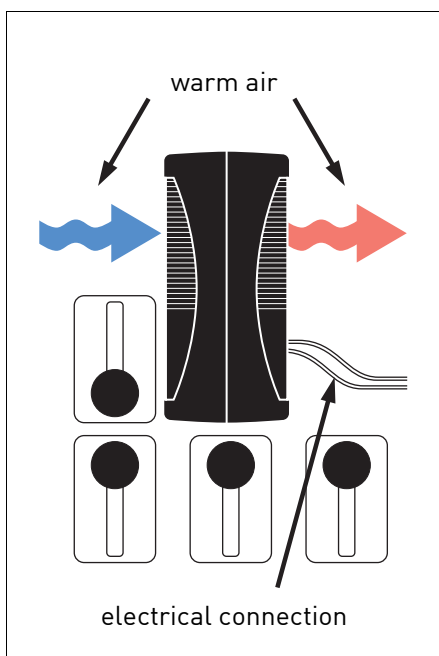

Install unit and fuel cartridge at the same level.

Secure the fuel-cartridge holder with four suitable screws and dowels, if necessary, so that it will not shake loose in the case of an accident.

## 5. Installing the Fuel Cartridge

### 5.2 Connecting the Fuel Cartridge



For safety's sake, use only original EFOY fuel cartridges. Do not smoke while changing the cartridge and avoid open flames! Do not expose fuel cartridges to temperatures above 45°C.



Original-equipment EFOY fuel cartridges contain EFOY-approved methanol. Even slight impurities in commercially available methanol may cause permanent damage to the unit and may void the guarantee.

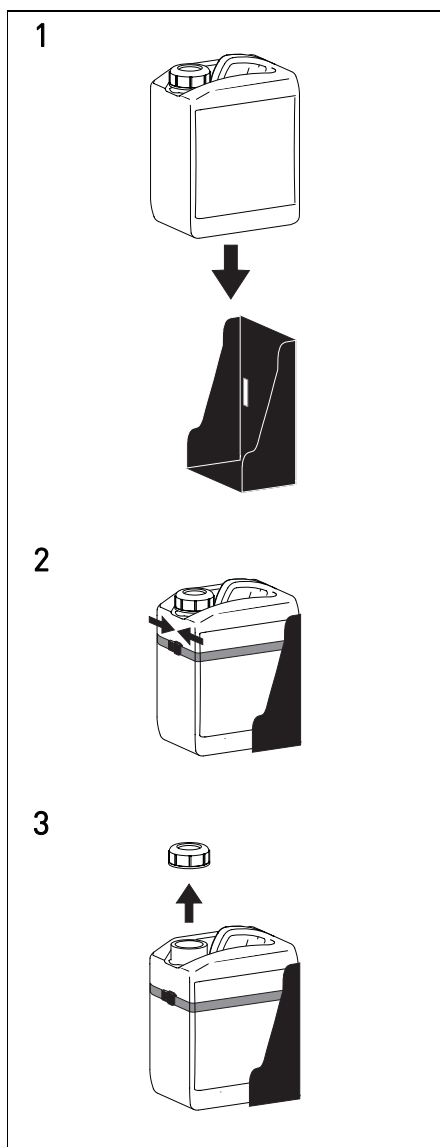

- Place a new sealed original-equipment EFOY fuel cartridge into the fuel-cartridge holder (1).
- Fasten the belt on the fuel-cartridge holder (2). Do not attach fuel cartridges without a fuel-cartridge holder.
- Remove the childproof cap only after placing the cartridge into the fuel-cartridge holder (3).
- Screw the connector onto the new fuel cartridge.
- Press **reset** on the control panel to extinguish the yellow warning light and the maintenance message.

## 6. Notes

## 6. Notes



## 6. Notes

