



Lighting Tower

User's Manual

Issue D July 2010



Taylor Construction Plant Ltd.
Quayside Industrial Park, Bates Road,
Maldon, Essex, CM9 5FA
Tel:+44 (0)1621 850777
Fax:+44 (0)1621 843330
mail@tcp.eu.com
www.tcp.eu.com

Contents

Preliminary	3	1.7 Moving the Trailer	15
Foreword	3	1.8 Redirecting the Lights	16
Warranty	3	1.9 Emergency Stop	17
<i>Liability</i>	3	Section 2 Routine Maintenance	19
<i>Audits and Surveys</i>	3	2.1 Schedule	19
<i>Service and Warranty Training</i>	3	2.2 Engine Oil Check	19
<i>Warranty Terms</i>	3	2.3 Engine Oil Change	20
<i>General Exclusions:</i>	3	2.4 Fuel Filters	20
<i>Warranty Claim Submission Procedures</i>	4	2.5 Oil Filter	21
Certificate of Conformity	4	2.6 Air Filter	22
Hatz Engine Dealers	4	2.7 Hydraulic Fluid	23
Service Bulletins	4	2.8 Tyres	24
Machine Identification	4	2.9 Inertia Brake	24
Theft Deterrence	4	2.10 Draining Fuel Tank	24
<i>Recovery of a Stolen Machine</i>	5	2.11 Engine Conditioning	24
Safety	5	Section 3 Lamp Replacement	25
<i>General</i>	5	Section 4 Fault-finding	27
<i>Fire Precautions</i>	6	4.1 Introduction	27
<i>Flammable Fluid Precautions</i>	6	4.2 Battery Light On	27
<i>Electrical Hazard</i>	6	4.3 Oil Pressure Light On	27
<i>Pre-Starting</i>	6	4.4 High Temperature Light On	27
<i>Starting</i>	6	4.5 Starting	27
<i>Lubrication and Servicing</i>	7	4.5.1 <i>Control Lights Off</i>	27
<i>Towing Safety</i>	7	4.5.2 <i>Engine does not crank</i>	27
Specifications	8	4.5.3 <i>Engine cranks as normal but engine</i> <i>does not fire</i>	27
Section 1 Operating Instructions	9	Section 5 Options	29
1.1 Features	9	Appendix A Timer and Dusk –Dawn	30
1.2 Positioning	9		
1.3 Uncoupling	10		
1.4 Jacking up the Unit	11		
1.5 Using the Lights	13		
1.6 Auxiliary Supply (Optional)	15		

Preliminary

Foreword

Thank you very much for purchasing this product. We believe that it will serve you without fail. Ensure that you read the operating instructions carefully before use. With proper handling and maintenance, this product will provide reliable, long-term service.

This manual is intended for users of the equipment.

All information, illustrations and specifications contained in this publication are based on the latest product information available at the time of publication. The right is reserved to make changes at any time without notice.

Continuing improvement and advancement of the design may cause changes to your machine that may not be included in this publication.

Please read the operating instructions carefully and understand them before operating the equipment.

Warranty

Liability

The warranty period begins when the product is delivered to and installed at the first purchaser. Only genuine parts may be used to carry out repairs. Failure to use only genuine parts may invalidate the manufacturer's warranty.

TCP Ltd will not be held responsible if:

- the machine has been used to perform tasks that demand more than its design and strength limitations, or
- the machine has undergone modifications not approved by TCP Ltd, or
- conditions of use have been abnormal, or
- normal maintenance, with regard to requirements as set out and detailed by the manufacturer, have not been adhered to.

TCP Ltd will not pay for normal maintenance or servicing nor any materials used to carry out routine servicing.

The warranty liability of TCP Ltd is limited to diagnosis, repair or replacement of the defective part, and actuating the repair - depending on the product terms and conditions, this will be free of charge.

TCP Ltd shall be under no liability whatever to the customer for any indirect loss and/or expense (including loss of profit) suffered by the customer arising out of a breach by TCP Ltd of this contract.

Audits and Surveys

TCP Ltd reserves the right to carry out audits and inspections from time to time in relation to any reimbursed or outstanding warranty claims in order to determine that all relevant details and information is correct.

Service and Warranty Training

Service and warranty training for service fitters can be provided at competitive rates if required. Training can be carried out at a TCP depot or at a venue of your choice, please contact TCP with your requirements.

Warranty Terms

One year or 1000 hours whichever occurs first from date of installation

All engine warranty issues must be directed to the engine manufacturer, or the manufacturer's approved/appointed engine dealer.

General Exclusions:

THE FOLLOWING ARE WARRANTY EXCLUSIONS AS DETERMINED BY HATZ:

Service items including lubricants, filters, glow plugs, fuel injection equipment, stop solenoid/relay, charge regulator, leaks (oil and air).

IN ADDITION: paintwork and parts that wear.

Warranty Claim Submission Procedures

Claims must be reported accurately and all relevant details given, as follows:

OWNERS NAME AND ADDRESS: full name and address of customer and site location, if different

MACHINE TYPE: State machine type, i.e. Ecolite

Date of Failure:

SERIAL NUMBER: Serial number of unit

ENGINE NUMBER: Serial number of engine

HOURS USED: State hours used on hour clock. Please do not guess the hours used

DETAILS OF FAILURE: Give a full report on the failure

ORDER NUMBER: An order number **will** be required

Note that the order number is to cover the diagnostic and call out time, as well as to determine the following:

- That the failure is to be covered under the terms and conditions of warranty. If this is the case, then the costs will be covered by TCP Ltd and the **order number will not be used**.
- If the failure is determined to be of a non-warrantable nature, further authorisation to continue will be sought before any rectification work takes place.

The information above must be provided even if your warranty claim is a “parts only” claim. An invoice will be raised for the exchange parts. The reported faulty/defective part must immediately be returned to TCP Ltd and full inspection of the parts carried out, if the failure is covered under the terms and conditions of warranty a credit note corresponding to the invoice will be despatched to the customer. If the failure is deemed to be of a non-warrantable nature, the invoice should be settled immediately.

Certificate of Conformity

Each machine is issued with a certificate of conformity that is sent to the head office of the purchaser. Further copies are available on request

Hatz Engine Dealers

To locate your nearest Hatz dealer, access the HATZ Worldwide page from the <http://www.hatz-diesel.de> web site.

Service Bulletins

TCP Ltd may from time to time issue service bulletins to keep you up to date as to any improvements or changes that may take place on the complete assembly or component parts.

Machine Identification

This manual may refer to controls and equipment that are not present on your particular machine. It is important that you know your machine and its equipment and how to operate it properly.

Information regarding the machine model, code and chassis serial number is on the unit serial number plate (*Fig 1*). This plate is on the front. Always quote the machine model and serial number in correspondence with your dealer or the factory.



 Tel: +44 (0)1621 850777 Fax: +44 (0)1621 843330	Taylor Construction Plant Ltd	
EC Approval No.		Type:
Vehicle Identification No.		
Gross Vehicle Weight		KG
Axle Weight 1		KG
Axle Weight 2		KG
		

Fig 1 Data plate

Theft Deterrence

The owner/operator should take the following precautions to discourage theft, to aid in recovery in the event that the machine is stolen, or to reduce vandalism.

- Remove all keys any time the machine is left unattended.
- Immobilise the machine by removing a critical electrical or starting system device.
- Upon receipt of a machine, record the machine serial number and the serial numbers of all-major components and attachments. Keep this list up to date and filed in a safe location for fast retrieval.
- Place a decal or notice on the machine stating that all serial numbers are recorded.

- Discourage the thief! Inspect the gates and fences of the machinery storage yard or construction site. Keep machines in well-lit areas and ask the local law enforcement authorities to make frequent checks around the storage yard or work site.
- Liaise with neighbours. Ask them to watch equipment left at job sites and to report any suspicious activities to local law enforcement authorities.
- Make frequent inventories of machines to promptly detect losses or vandalism.

Recovery of a Stolen Machine

In the event of theft, immediately notify the law enforcement authorities having jurisdiction. Provide the investigating officer with name, type of equipment, chassis and serial numbers of major attachments and components. It would be helpful to show the investigating officer an Operator's Handbook, photographs, and advertising, to familiarise him with the appearance of the machine.

Report the theft to the insurance company. Provide the model and all serial numbers.

Report the model and serial numbers of the stolen machine to a dealer handling the respective line of equipment. Request that the dealer forward this same information to the equipment manufacturer.

Safety

Report all malfunctions to those responsible for maintenance. Do not operate the equipment until corrected. Normal service or maintenance performed as required can prevent unexpected and unnecessary down time. This handbook describes general inspections, servicing and operation with the normal safety precautions required for normal servicing and operating conditions. It is not a guide however, for other than normal conditions or situations.

Operators and service engineers must be safety conscious and alert to recognise potential operating or servicing safety hazards at all times, and take, necessary precautions to ensure safe operation and servicing of the machine.

General

WARNING

- Read this operator's Handbook and learn the operating characteristics and limitations of the machine. Know what operating clearances the machine requires.
- Know clearances of all side and overhead obstructions such as wires, etc., for operating safety.
- Be aware of operating hazards that weather changes can create on the job. Know proper procedures to follow when a severe rain or electrical storm strikes.
- Know what safety equipment is required and use it. Such equipment may be hardhat, safety glasses, reflector type vests, respirators and earplugs.
- Handle fuels and lubricants carefully and clean up spills to avoid fire and slipping hazards.
- Never rush. Walk do not run.
- Ensure that the area immediately surrounding the light tower is clean, neat and free of debris.
- Position and operate light tower on a firm , level surface.
- **NEVER** start a unit that is in need of repair.
- Lower tower when not in use, or if high winds or electrical storms are expected in the area.
- The tower extends up to 9 m (30 ft.). Make sure area above the tower is open and clear of overhead wires and obstructions.
- Bulbs become extremely hot is use! Allow bulb and fixture to cool 10-15 minutes before handling.
- Keep area around tower clear of people while raising and lowering mast!
- Tower must be levelled and outriggers extended before raising tower. Outriggers must remain extended while tower is up.
- **DO NOT** use a lamp without the glass lens of the lamp unit in place and undamaged. Ceramic discharge metal halide lamps are constructed of an outer glass bulb with an internal arc tube made of ceramic. The arc tubes operate at high pressure (up to 50 p.s.i.) and at very high temperatures. They can rupture unexpectedly due to ballast

failure or misapplication. If an arc-tube ruptures, it can shatter the outer glass bulb resulting in the discharge of glass fragments and extremely hot ceramic particles (as high as 18320F, 1000C). In the event of such rupture, there is risk of personal injury, property damage, burns and fire if the protective lens is not fitted.

Fire Precautions

WARNING

- Clean all dirt, oil, grease and other fluids from systems and components to minimise fire hazards and aid in spotting loose or leaking lines, fittings etc.
- Check the engine for rubbish, oily rags or other debris that could cause fires before starting the engine.
- Safely dispose of greasy, oily rags or similar hazards.

Flammable Fluid Precautions

WARNING

- Take due care when working with fuel. Diesel fuel is a health hazard for contact with eyes or sin, inhalation and ingestion. There is also danger of fire and pollution.
- Don't use diesel fuel or other flammable fluids for cleaning purposes. Use approved non-flammable solvents.
- Make sure all-fluid systems caps, drain, valves, fittings, lines etc., are secure and leak free.
- Shut off engine and use extra caution if engine is hot when refuelling. Never smoke while checking or adding fuel or other fluid or handling fluid containers and lines.
- Use care and do not stand downwind when adding fuel or other flammable fluids to tanks and reservoirs to avoid fluids being blown or splashed onto clothing.
- When preparing machines or components for storage, seal and tape all openings and close containers tightly to seal in all volatile inhibitor fluids and compounds used.
- **DO NOT** fill fuel tank near an open flame, while smoking, or while engine is running.

- **DO NOT** fill tank in an enclosed area with poor ventilation.
- **DO NOT** run engine with the fuel tank cap loose or missing.

Electrical Hazard.

WARNING

- Never smoke or allow open flames or sparks near batteries.
- Always disconnect batteries before repairing electrical system to avoid danger of fire-causing sparks. Disconnect battery ground cable first and reconnect last.
- Always disconnect batteries and alternator leads before carrying out any welding on the machine.
- Never check battery charge by placing metal objects across battery posts to avoid sparks at battery posts.
- Use jumper cables only as recommended. Improper use can result in battery explosion.
- Make certain light tower is well grounded and securely fastened to a good earth ground.
- **NEVER** use tower if insulation on electrical cord is cut or worn through.
- **NEVER** operate lights without protective lens cover in place or with a lens cover that is cracked or damaged!

Pre-Starting

WARNING

- If engine is to be started and run indoors, ensure proper ventilation to remove deadly exhaust gases.
- Always perform 'Pre-Starting Inspection' instructions described in this manual to ensure the machine is ready for operation.

Starting

WARNING

- Do not start the engine or operate any control if there is a 'DO NOT OPERATE' or similar warning sign attached to any control.
- Use jumper cables only as recommended. Improper use can result in battery explosion or unexpected machine motion.

Lubrication and Servicing

WARNING

- Do not allow unauthorised personnel to service or maintain the machine. Study the Operator's handbook and Service Manual before starting, operating or servicing the machine.
- Always relieve pressure before servicing any pressurised system.
- Use only the special hydraulic fluid supplied by TCP. Unapproved or diluted fluid could freeze in cold conditions resulting in damage to the equipment and/or danger to personnel.
- **DO NOT** touch or lean against hot exhaust pipes or engine cylinder.
- **HIGH VOLTAGE!** This unit uses high voltage circuits capable of causing serious injury or death. Only a qualified electrician should troubleshoot or repair electrical problems occurring in this equipment.
- Replace all guards and safety devices immediately after servicing.
- Before servicing light tower, make sure engine start switch is turned to OFF, circuit breakers are open (off) and the battery isolation key is removed. **NEVER** perform even routine service (oil/filter changes, cleaning, etc.) unless all electrical components are shut down.
- Never allow water to accumulate around the base of the light tower set. If water is present, **DO NOT** service!
- Never service electrical components if clothing or skin is wet. If the unit is stored outside, check the engine and generator for any moisture and dry the unit before use.
- Never wash the unit with a power washer or high pressure hose.
- Open main circuit breaker before disconnecting battery cables.
- Keep hands, feet, and loose clothing away from moving parts on generator and engine.
- Replace all missing and hard-to-read labels. Labels provide important operating instructions and warn of dangers and hazards.
- Make sure slings, chains, hooks, ramps, jacks, and other types of lifting devices are attached securely and have enough weight-bearing capacity to lift or hold the equipment safely.

Always remain aware of the position of other people around you when lifting the equipment

Towing Safety

WARNING

Towing a trailer requires care! Both the trailer and vehicle must be in good condition and securely fastened to each other to reduce the possibility of an accident.

- Check that the hitch and coupling on the towing vehicle are rated equal to, or greater than, the trailer's "gross vehicle weight rating" (GVWR).
- Inspect the hitch and coupling for wear or damage. **DO NOT** tow trailer using defective parts!
- Make sure the coupling is securely fastened to the vehicle.
- Check tyres on trailer for tread wear, inflation, and condition.
- Connect breakaway safety line securely to towing vehicle.
- Make sure directional, reverse and trailer lights are connected and working properly.
- Check that wheel nuts are tight and that none are missing.
- Maximum recommended speed for highway towing is 75 kph. Recommended maximum off-road towing speed is 15 kph (less on uneven terrain).
- Check that the road running lights are connected and operating, if applicable.

Preliminary

Specifications

Overall length	2503 mm
Overall height, floodlighting position	9500 mm
Overall mast height	8740 mm
Overall height, travel position	2200 mm
Overall width, travel position	1455 mm
Overall width with jack legs deployed	2106 mm
Tow hitch height	420 mm
Wheel size	155/ R13
Axle weight (GVM)	1000 kg
Total weight, with fuel	750 kg
Stabilizing/levelling positions	4
Lamps	4 or 6
Operating voltage	110 cte /220V
Engine	Hatz IB20
Engine power	3.1 kW
Engine oil capacity	2.6 l
Fuel consumption	0.5 l/hour
Fuel tank capacity	95 lts
Total run time	170 hours
Fuel specification:	Diesel meeting EN 590, BS 2869 A1 / A2 or ASTM D 975 - 1D / 2D
Braking System	Fully fitted axle braking
Ground clearance	240 mm
Max wind speed for safe operation	Up to 100 kph

Additional Safety Systems:

Automatic Mast Operating Safety System
(AMOSS) fitted as standard

Section 1 Operating Instructions

1.1 Features

- Four or six adjustable, ceramic discharge metal halide lamps mounted on a telescopic tower.
- 9m tower raised and lowered using hydraulics powered by a Hatz diesel engine.
- Lights powered from the diesel engine or (optionally) from a local mains supply.
- Mounted on a two-wheel trailer that can either be lifted onto a vehicle for transport or towed.
- AMOSS system prevents towing while the mast is raised. The mast cannot be raised unless the handbrake is on.

1.2 Positioning

When choosing a location of the Ecolite, bear in mind the following:

- The light tower should not be placed where those working under the light are:
 - Forced to look into the light regularly or
 - Forced to work with their backs to the light (shadows will block the light from the work area).
- Assess site conditions carefully before positioning and operating the tower.
- Do not position the tower in the vicinity of overhead cables or power lines!
- Locate the light tower on the same or a higher level than the area being lit (the higher the light, the less shadow length).
- The area where the tower is positioned should be relatively level. This will ensure smooth, trouble-free telescoping of the mast. (The mast may not telescope down properly if the unit is not level.)
- Put the handbrake on before attempting to raise the mast. **The mast cannot be raised unless the handbrake is on.**
- Do not move the tower with the mast raised! (The mast will telescope down automatically if the brake is released).
- Never raise the mast or operate the tower without the jacklegs touching the ground!

The Ecolite would normally be towed into the required position and then uncoupled from the towing vehicle. However, the Ecolite has a lifting point for use with a crane and two pockets for use with a forklift (*Fig 1-1*) that can be used.

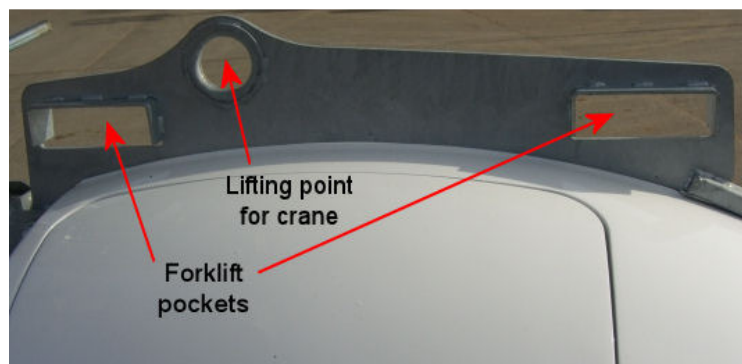

Fig 1-1 Lifting points

1.3 Uncoupling

⚠ WARNING Do not release the Jockey Wheel Assy. Clamp Lever while the Jockey Wheel is taking the weight of the unit. The unit would tip forward and could cause damage or personal injury.

Uncouple the Ecolite trailer from the towing vehicle, if necessary, as follows:

1. Apply the parking brake by pulling up the lever (Fig 1-2). The mast cannot be raised unless the brake is on.
2. Disconnect the trailer lighting from the towing vehicle.
3. Detach the breakaway cable from the towing vehicle.
4. Release the jockey wheel assembly clamp and lower the wheel approximately half way to the ground.
5. Retighten the clamp.
6. Wind the jockey wheel down to release the weight from the towing eye.
7. Release and remove the pin from the towing eye on the towing vehicle.
8. Make any final adjustments to the position of the unit and apply the parking brake by pulling the lever upward to the limit of its travel.

Coupling the unit to a towing vehicle is the reverse of this procedure. Before moving off, check the tyres and check that the lights on the trailer work.

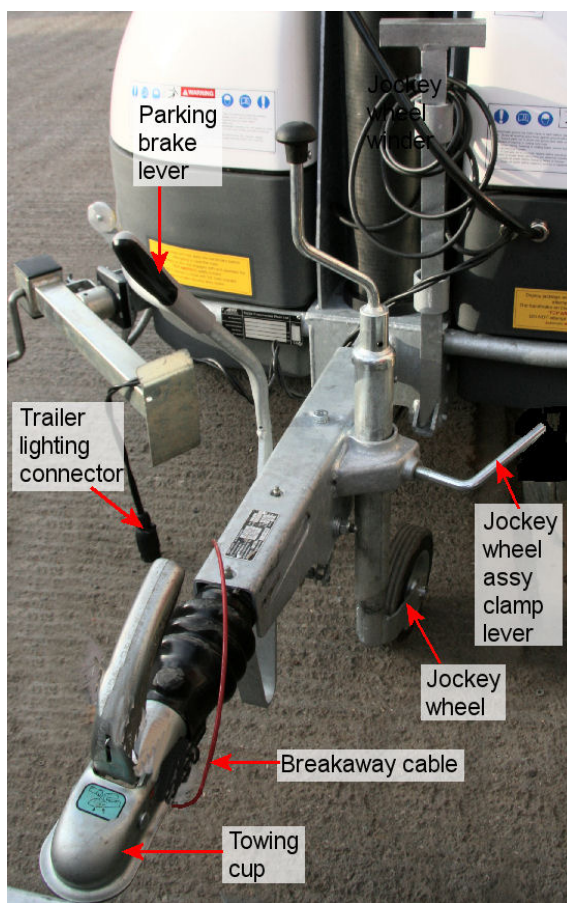

Fig 1-2 Parking brake

1.4 Jacking up the Unit

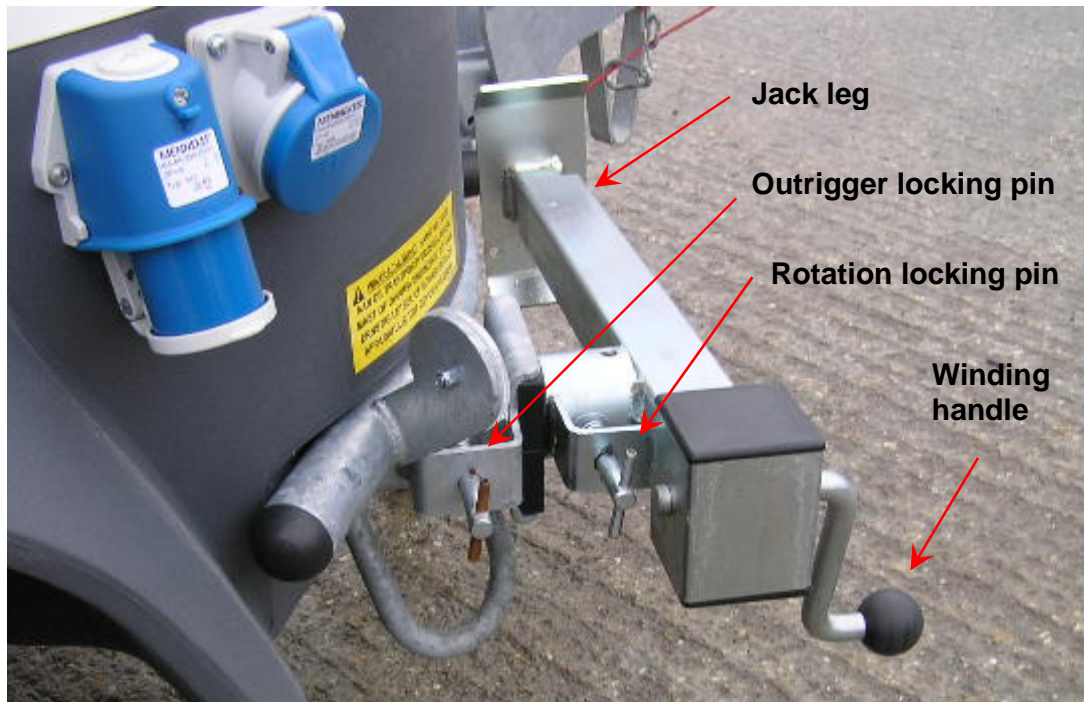

Fig 1-3 Jack components

Jack up the unit as follows. Start with the jack that is on the highest ground.

1. Hold the Jack Leg with one hand and pull the Rotation Locking pin to release the leg. Allow the leg to fall to the vertical position. Ensure that the pin locks the leg in the vertical position (Fig 1-4).



Fig 1-4 Jack vertical

Section 1 Operating Instructions

2. Pull out the Outrigger Locking Pin (Fig 1-5) and pull the Jack Leg away from the body of the unit to its fullest extent (Fig 1-6).



Fig 1-5 Extending the jack



Fig 1-6 Jack extended

3. Wind the foot of the jack down to the ground (Fig 1-7).



Fig 1-7 Jacking up

Repeat the procedure for all four jacks so that the unit is stable and level. Do not use the jacks to raise the tyres off the ground.

1.5 Using the Lights

1. Check that the brake is on. Note that the mast cannot be raised if the brake is off. Check that the brakes are operating correctly on both wheels by attempting to move the trailer.
2. Check that the light lenses are clean and undamaged.
3. Drive the earth spike (Fig 1-13) into the ground (earth) (follow any risk assessment). Check that the earth spike cable is securely attached to the unit.
4. Check that the Emergency Stop button is not pressed. If necessary, rotate the button clockwise to release it.
5. Open the cover to access the Control Panel.
6. Check the fuel level and top up if necessary. (The fuel level can be seen through the translucent fuel tank.)

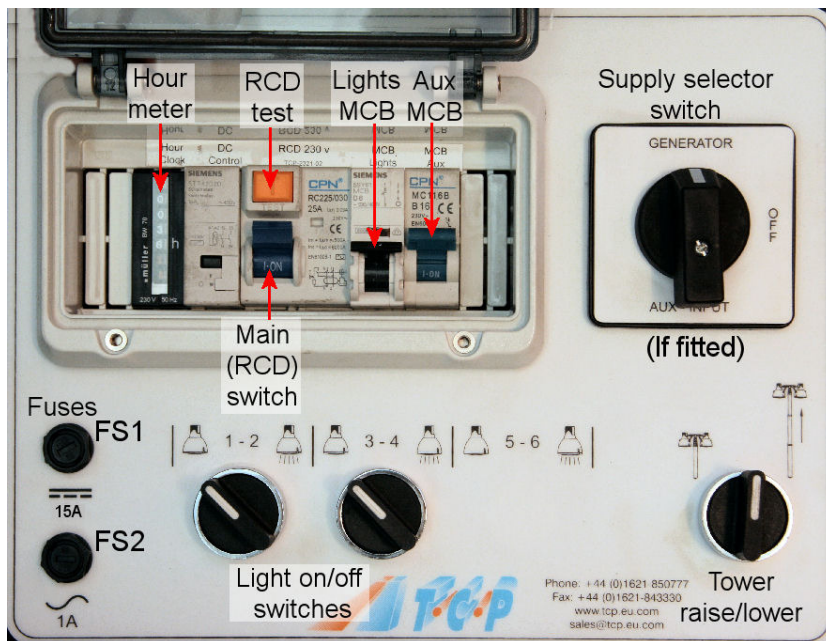

Fig 1-8 Control panel

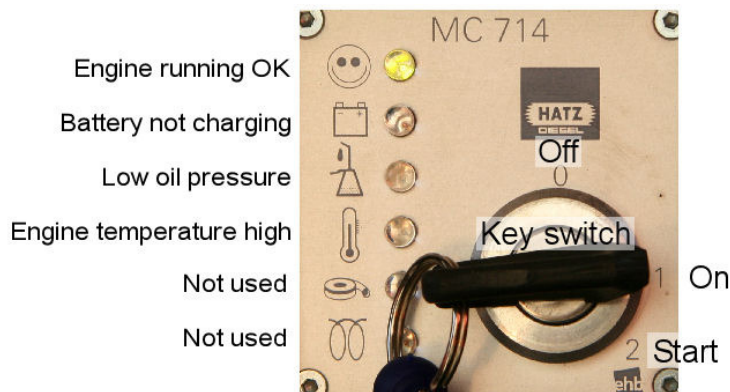

Fig 1-9 Ignition panel

Note: Fig 1-8 shows a 230V machine with an auxiliary output. The mcb configuration on other versions will be different.

Section 1 Operating Instructions

7. Check that the main switch and miniature circuit breakers (MCBs) are on (up) and the Light switches are off. (The main switch is a residual current device (RCD) that can be tripped by an earth leakage.)
8. Set the Supply Selector Switch (if fitted) to Off.
9. Insert the key in the Key Switch and turn it to position **1**. The Battery and Oil Pressure lights adjacent to the switch should light.
10. Turn the key to position **2**.
11. As soon as the engine starts, release the Key to position **1**. Check that the Battery and Oil Pressure lights go out and the green, Running light remains on.

Note: If the engine does not start, return the key switch to position 0 before retrying.

12. Check that the lights on the tower are oriented so as to provide optimum illumination of the site. The lights can be tipped up/down and rotated, as required. It is also possible to rotate the tower through 300 degrees. See *Section 1.8 Redirecting the Lights*.
13. Raise the tower by turning the Tower switch clockwise and holding it there.

Note: If the tower cannot be raised, check that the Mast Lowering Valve is closed (see Fig 1-10).

14. Release the Tower switch when the lights reach either the required height or maximum. You will hear a change in the pitch of the hydraulic motor when the mast is fully extended.

Note: It is normal for the mast to appear wet as it is raised: the hydraulic fluid acts as a lubricant for the seals between the telescopic sections. Subsequent leakage from a raised mast could indicate a problem with a seal. Seals and O-rings can be replaced as detailed in the workshop manual.

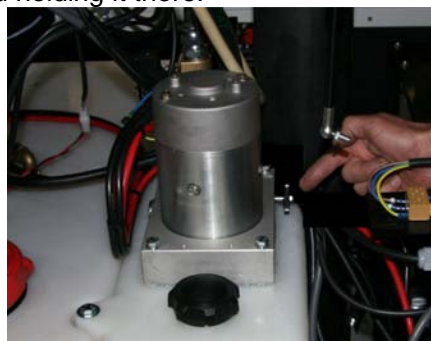

Fig 1-10 Mast Lowering Valve

15. Set the Supply Selector switch (if fitted) to **Generator**.
16. Set the Light switches to **On** (clockwise). The lamps take a minute or two to warm up.
17. Close the cover to protect the Control Panel.

Closing down the unit is the reverse of this procedure.

Before lowering the tower, switch off the lights and allow time for them to cool.

To stop the engine, turn the Key Switch to **0**.

1.6 Auxiliary Supply (Optional)

Where an input plug is fitted (Fig 1-11), the lamps can be powered from a local mains supply instead of from the generator. Connect the mains supply to the Aux input plug (Fig 1-11).

Note: To avoid depleting the battery, the unit is configured so that the mast can only be raised with the engine running.

To use the auxiliary supply, follow the instructions given in *Section 1.5 Using the Lights* but set the Supply Selector switch to **Aux Input** in Step 15. On completion, turn off the generator, leaving the lights powered from the Auxiliary mains input.



Fig 1-11 Auxiliary supply connectors

Where an output socket is fitted, it provides either 110V centre-tap earth (cte) or 220V output (depending on version/region) from the internal alternator.

1.7 Moving the Trailer

The trailer cannot be moved with the tower raised. (Releasing the brake causes the tower to telescope down.) To move the trailer:

1. Turn off the lights and allow time for them to cool.
2. Lower the tower.
3. Ensure that the jockey wheel is down and locked so that the unit will not tip over when the jacks are removed.
4. Raise, retract and stow the four jacks.

The unit can be either manhandled or towed to the new location.

Before towing:

- Check that the hitch and coupling on the towing vehicle are rated equal to, or greater than, the trailer's "gross vehicle weight rating" (GVWR).
- Inspect the hitch and coupling for wear or damage. **DO NOT** tow trailer using defective parts!
- Make sure the coupling is securely fastened to the vehicle.
- Check tyres on trailer for tread wear, inflation, and condition.
- Connect breakaway safety line securely to towing vehicle.
- Make sure directional, reverse and trailer lights are connected and working properly.
- Check that wheel nuts are tight and that none are missing.

The maximum recommended speed for highway towing is 75 kph. Recommended maximum off-road towing speed is 15 kph (less on uneven terrain).

1.8 Redirecting the Lights

The tower can be rotated through up to 300 degrees so as to direct the light as required.

Slacken the Rotation Lock (Fig 1-13) and turn the Rotation Handle so as to direct the lights as required. Tighten the lock afterwards.

In addition to rotation of the mast, each of the lights can be rotated on two axes and tipped back and forth (Fig 1-12). Thus the lights can be directed either downwards or horizontally (e.g. to illuminate a façade (Fig 1-14)). For any adjustments, the mast must be lowered to allow access.

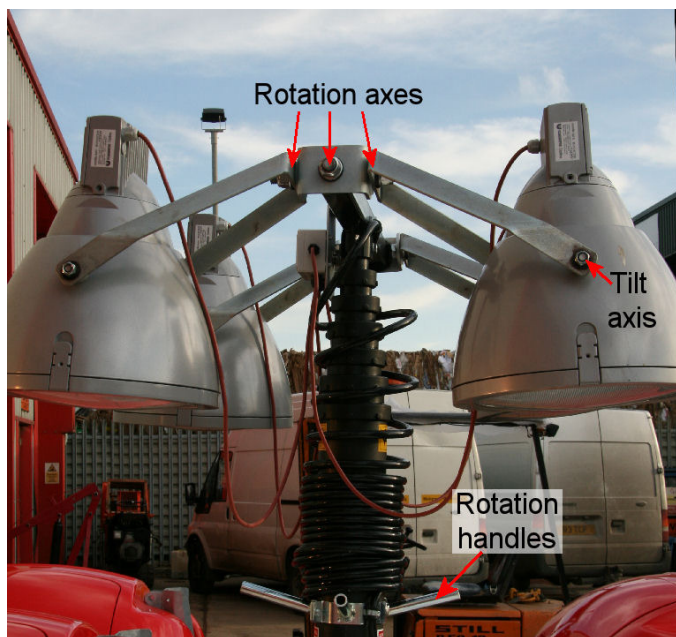

Fig 1-12 Light manipulation



Fig 1-13 Rotation lock



Fig 1-14 Façade illumination

1.9 Emergency Stop

The Emergency Stop button shuts off the engine in under 20 seconds.

The engine (and the power it generates) will remain off until the Emergency Stop button is released. To release the button, twist it in the direction of the arrows on the button.

Note: When Ecolite power is supplied from an outside source via the input socket (engine not used and supply Selector switch set to Auxiliary) the Emergency Stop button is inoperative and will not turn off the power.
The RCD provides protection against electric shock.



Fig 1-15 Emergency Stop button

Section 1 Operating Instructions

Section 2 Routine Maintenance

2.1 Schedule

Operation	Service interval					Ref. Page
	Daily	Every 250 hr	Every 500 hr	Every 1000 hr	Every 1500 hr	
Engine Oil	Check	Change				19 & 20
Air filter		Check/replace				21
Fuel Filter – in-line		Replace				20
Fuel Filter – fixed			Replace			20
Hydraulic fluid	Check					23
Engine oil filter				Clean		21
Lubricate inertia brake				Grease		24
Drain water from fuel tank				Annually		24
Engine conditioning					Decoke	24

*Check/clean air filter daily in dusty conditions.

2.2 Engine Oil Check

Check the engine oil after each day's use.

1. Ensure that the unit is level.
2. Check the oil level with the engine cold.
3. Clean the area around the oil filler cap/dipstick.
4. Remove the dipstick (*Fig 2-1*) and allow a few moments for the oil level to settle.
5. Check the oil level using the dipstick (*Fig 2-2*).
6. If necessary, top up the oil (see *Fig 2-3*). Do not overfill.

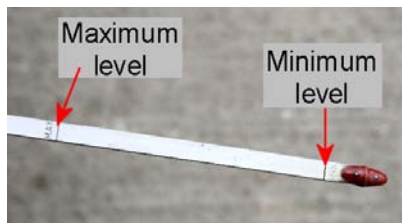

Fig 2-2 Dipstick levels

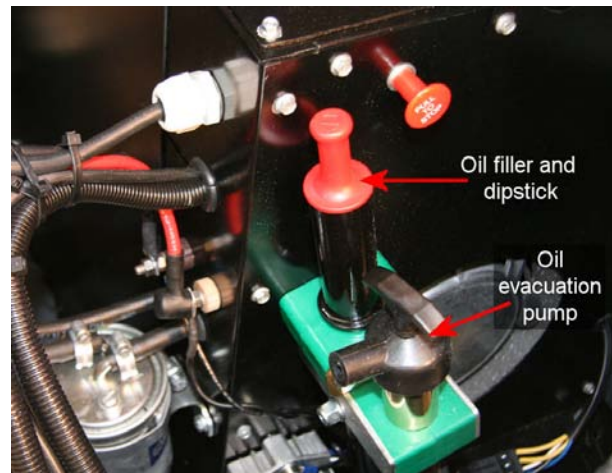

Fig 2-1 Oil filler/dipstick and pump

2.3 Engine Oil Change

Change the oil every 250 operating hours.

Take care that no contamination enters the sump

1. Ensure that the unit is level.
2. Run the engine until it is warm.
3. Clean the area around the oil filler cap/dipstick.
4. Remove the filler cap/dipstick (*Fig 2-1*).
5. Attach a suitable tube to the oil evacuation pump and route it to a suitable container.
6. Use the hand pump to evacuate all the oil from the sump.
7. Disconnect the tube.
8. Refill the sump with oil of the correct grade for the conditions (*Fig 2-3*) to the correct level, as indicated on the dipstick.
9. Refit the filler cap/dipstick.

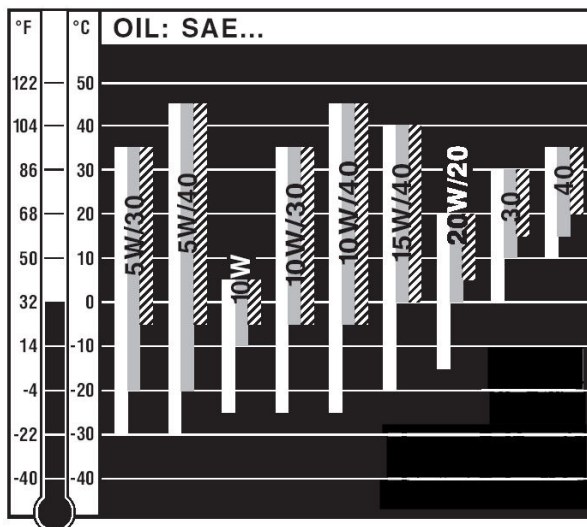

Fig 2-3 Oil SAE grades

Oil should meet at least one of the following specifications:

ACEA – B2 / E2 or better

API – CD / CE / CF / CF-4 / CG-4 or better.

If engine oil of a poorer quality is used, reduce oil change interval to 150 hours of operation.

2.4 Fuel Filters

Parts:

In-line fuel filter TCP 14-0131

Fixed fuel filter TCP 14-0128

Two fuel filters are fitted: one behind the battery, in the line to the fuel pump (*Fig 2-4*) and the other mounted on the side of the engine (*Fig 2-5*). Replace the in-line filter after 250 hours of operation and the fixed filter after 500 hours.

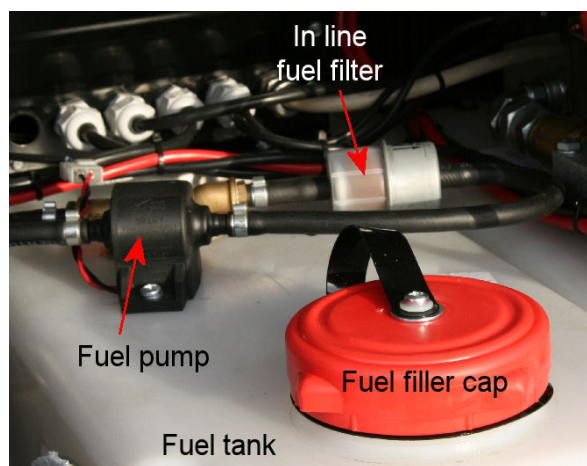

Fig 2-4 In-line fuel filter



Fig 2-5 Fixed fuel filter

2.5 Oil Filter

Clean the oil filter after every 1000 operating hours.

1. To gain access to the oil filter it is necessary to remove the side panel from the engine. Fig 2-7 shows the side panel and some of the fixing screws. The oil filter is located near the bottom of the engine (Fig 2-6).



Fig 2-6 Engine oil filter

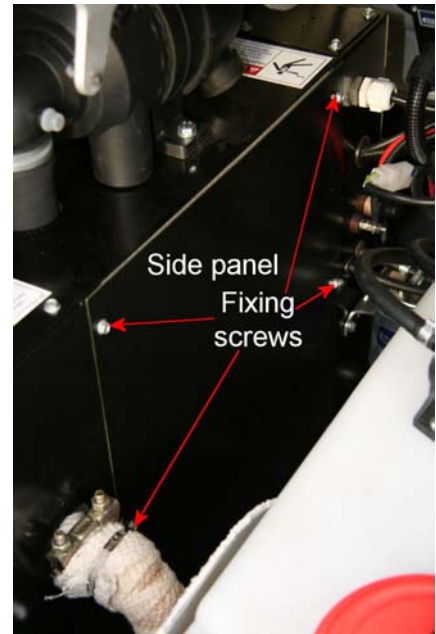

Fig 2-7 Engine side panel

2. Wash out oil filter with degreaser. Replace filter if damaged.

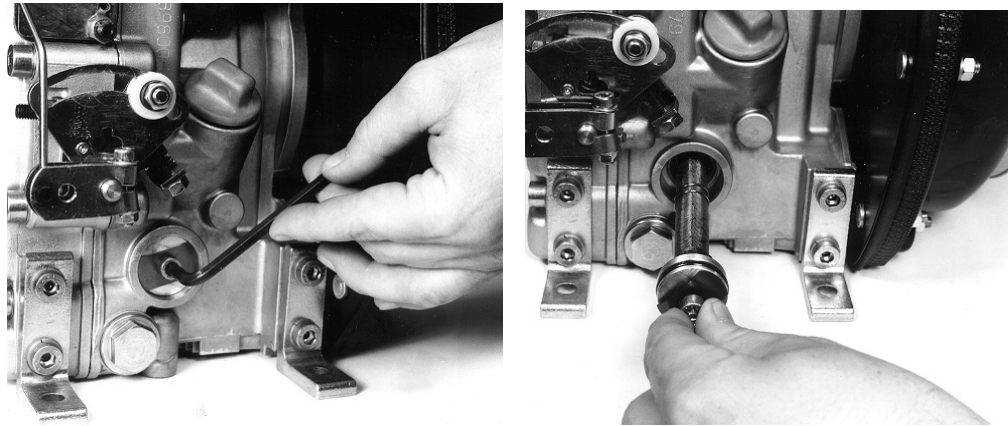

Fig 2-8 Oil filter removal

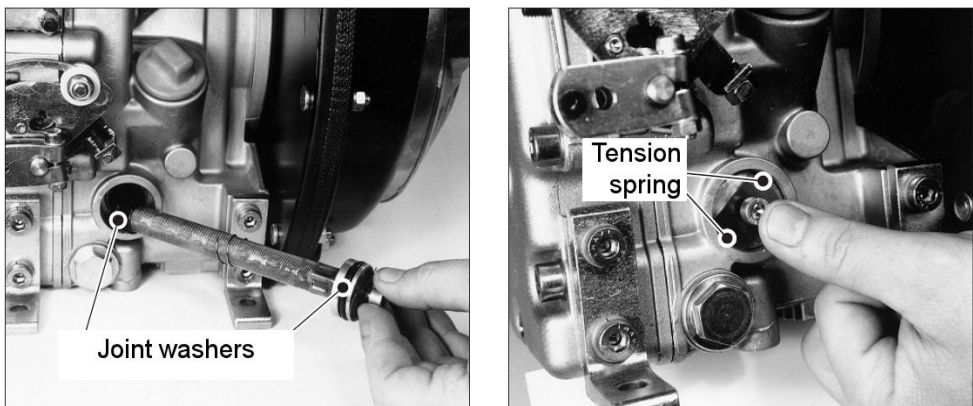

Fig 2-9 Oil filter refitting

3. Check joint washers (Fig 2-9). Replace if necessary.
4. Lubricate joint washer before fitting.
5. Insert filter to limit of travel. Ensure that tension springs (Fig 2-9) sit close to filter before tightening screw.
6. Check oil level and top up as necessary.

2.6 Air Filter

Parts:

Air filter element	TCP 10-0273
Safety element	TCP 10-0274

Check the air filter every 250 operating hours - daily under dusty conditions. The filter comprises an outer filter element and an inner safety element, intended to stop the filter element being sucked in.

1. Open the cover to access the air filter assembly.
2. Unscrew the air filter cover (Fig 2-10).
3. Extract the filter element (Fig 2-11).
4. Extract the inner, safety element (Fig 2-12).



Fig 2-10 Air filter cover removal



Fig 2-11 Air filter element

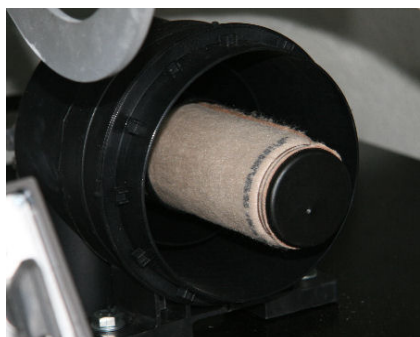

Fig 2-12 Safety element

5. Replace filter if damaged or dirty.
6. Reassemble the filter assembly.

2.7 Hydraulic Fluid

Check the fluid in the hydraulic tank daily.

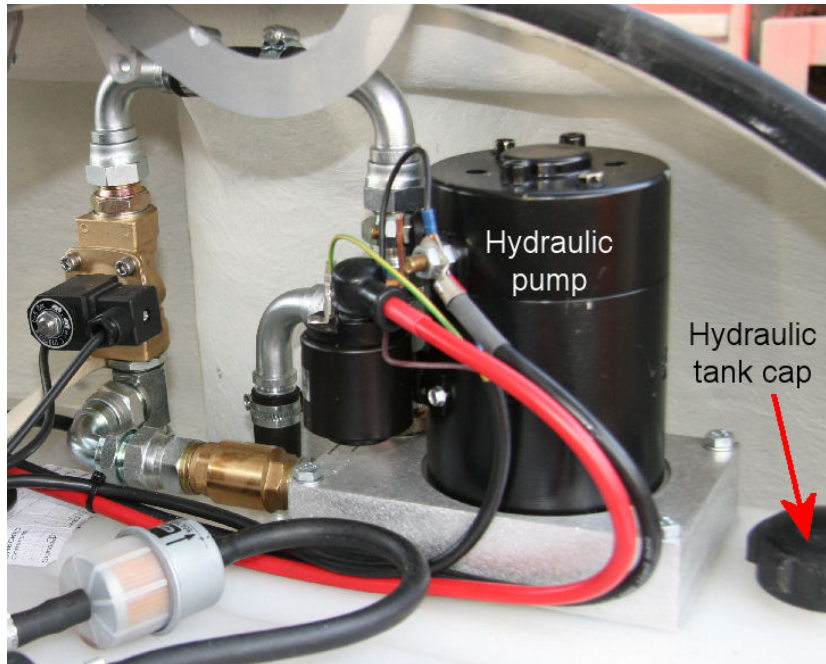

Fig 2-13 Hydraulics

Remove the cap from the hydraulic tank and check the level. The fluid should just reach the bottom of the filter that is under the cap (Fig 2-14). If necessary, top up with Ecolite Mast Fluid (TCP Part No. 80-0372).

Warning: Only use the specified TCP hydraulic fluid (undiluted). This fluid is specially formulated for the purpose. If the wrong fluid is used or the fluid becomes diluted, it could freeze under cold conditions with resultant structural damage to the equipment. This could result in injuries to personnel and/or damage to property.



Fig 2-14 Hydraulic fluid level check

If it is suspected that the fluid has become diluted, drain the tank (as described for the fuel, in *Section 2.10 Draining Fuel Tank*) and refill with the prescribed TCP fluid.

Take care not to mix fuel and hydraulic fluid.

2.8 Tyres

Check the condition of the tyres. They should meet local wear regulations if used on public roads.

Check the tyre pressures They should be 2.5 bar (35 psi).

2.9 Inertia Brake

The inertia brake applies the trailer brakes when the towing vehicle brakes.

Apply medium multipurpose grease to the nipples (Fig 2-15).

The frequency of greasing depends on the extent of towing. If the trailer is towed frequently, with frequent braking, the brake will need more frequent greasing than if the brake is seldom used.

Inspect the brake every three months. If adequate lubricant is showing, grease annually.

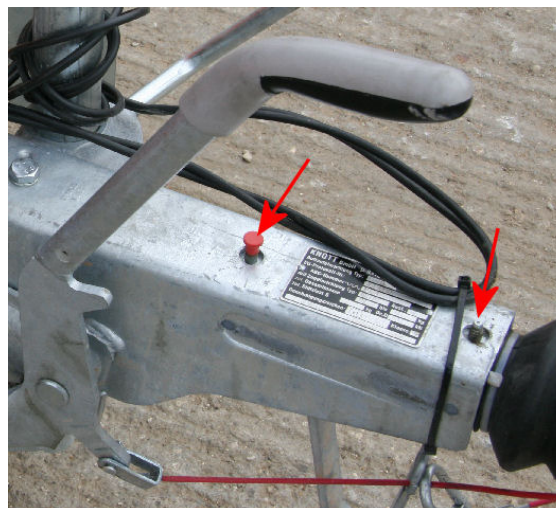

Fig 2-15 Inertia brake grease nipples

2.10 Draining Fuel Tank

⚠ WARNING

When working on the fuel system, do not expose it to a naked flame; do not smoke.

Over time, condensation results in a layer of water forming at the bottom of the fuel tank, water being heavier than diesel fuel. Once per year, remove the water as follows:

1. Fit a polyethylene tube (diameter 4 mm, length 700mm approx.) to a commercial syringe (20 ml or larger).
2. Remove the diesel filler cap and run the tube down to the bottom of the tank.
3. Drain off the fuel/water mixture with the syringe.
4. Repeat the procedure until the transparent syringe is found to contain only diesel fuel.

2.11 Engine Conditioning

After every 1500 hours of operation, the engine should be run under a 2.6 kW load for two hours in order to clear it of accumulated carbon deposits. The 2.6 kW can comprise a 2 kW load connected to the Auxiliary Supply output plus 600W for the lights.

Section 3 Lamp Replacement

Note: Do not touch the lamp bulb with bare fingers. The grease deposited from skin will cause the lamp to fail when it is turned on. Ensure that the new lamp is clean.

1. Release the clips securing the lens (Fig 3-1) and remove the lens (Fig 3-2).



Fig 3-1 Lens clips



Fig 3-2 Lamp lens

2. Unclip the lamp from the holder (Fig 3-3).
3. Install the new lamp and refit the lens.

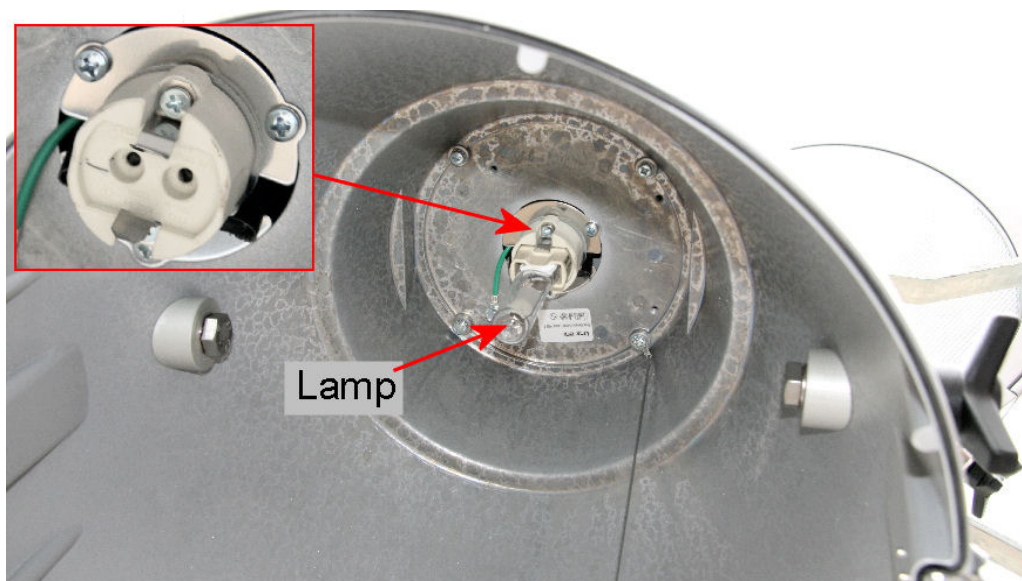

Fig 3-3 Lamp and holder

Section 3 Lamp Replacement

Section 4 Fault-finding

4.1 Introduction

The Hatz engine is a very reliable unit, dirty fuel being the most likely problem. This section covers the remaining most likely problem areas. Any other faults should be handled by a competent engineer referring to the Ecolite Workshop Manual.

4.2 Battery Light On

If the engine is running, this lamp indicates that the battery is not charging. Check the alternator and regulator.

4.3 Oil Pressure Light On

Check the oil level (*Section 2.2 Engine Oil Check*).

4.4 High Temperature Light On

If the engine has been running for a while and the High Temperature light is on, check the cooling fan. If the Fan indicator lamp (Fig 1-9) is lit, check the supply to the fan.

4.5 Starting

4.5.1 Control Lights Off

On turning the key switch to I (On), no indicator lamps light.

- Check that Emergency Stop button is released. Turn button in direction of arrows.
- Check the battery voltage as detailed below.

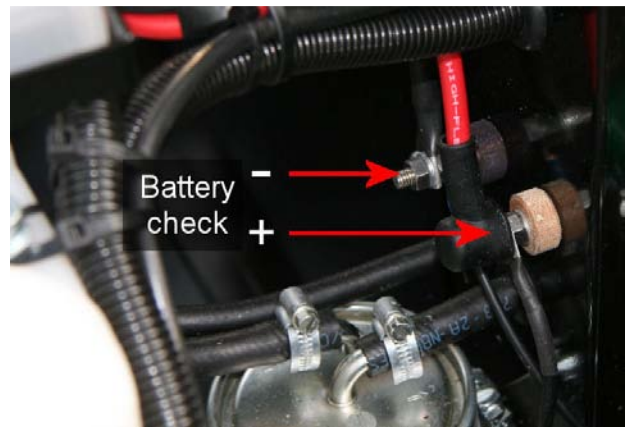

Fig 4-1 Battery voltage check

4.5.2 Engine does not crank

- Check that Supply Selector switch is set to Off. Engine will not start with this switch set to Auxiliary.
- Check battery as follows.

Measure (12V) battery voltage at terminals on side of motor (*Fig 4-1*). Check voltage with start switch in each of its three positions. The voltage should be around 12V off load (switch position 0) and should not fall below 10V while cranking. (Fuel pump operation should be audible in switch position 1.)

4.5.3 Engine cranks as normal but engine does not fire

- Check fuel level in tank.
- Check that the fuel pump operates when the start switch is set to I. Pump operation should be audible.
- Check fuel and filters.

Section 5 Options

Appendix A - Timer and Dusk-Dawn Functions

A1. Introduction

This appendix describes two automatic operation options:

- A timer can be fitted to turn the lights on and off at pre-determined times for every day of the week.
- A sensor can be fitted on top of the mast to turn the lights on at dusk and off at dawn.

Only one option can be fitted to a given unit.



Fig A1 Timer and ignition panel

A2. Ignition Panel

The key switch on the (Capricorn) ignition panel has three positions:

- Manual on - engine starts and lights come on if selected. (If lights fail to come on, check that dip-switch A4 is On. See Section A11. Ignition Unit Settings.)
- Off - engine turns off and lights go off.
- Auto on - engine and lights are controlled by the **Dusk-dawn** sensor or the **Timer**, according to which is fitted.

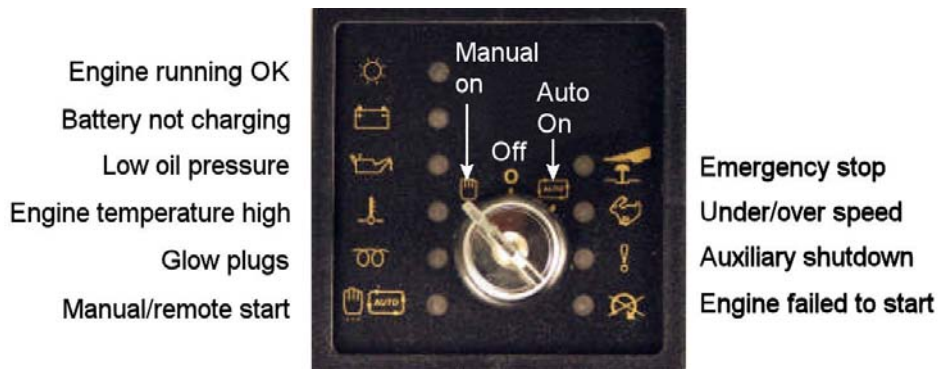

Fig A2 Ignition panel

A3. Timer

A3.1. Introduction

The timer allows the engine and lights to be turned on and off at predetermined times on a weekly basis. (The mast is not affected and remains in the set position.)

The front panel buttons can be used to set numerous On and Off switching points at particular times on particular days or groups of days of the week, e.g. Monday to Friday or Saturday and Sunday. There are also various options for dusk and dawn switching. Press the **SET** button repeatedly to see the switching points that are currently set. Examples:

On 19.00	Off 2100	Monday to Thursday
On 21.00 Monday		Off 05.00 Tuesday
On at Dusk	Off after 1 hr	Every day

Either manual or automatic daylight saving time (e.g. British Summer Time) can be implemented.

To access the timer, raise the control panel window and flip up the window covering the timer. The timer window can be used to prop up the control panel window.

The timer normally shows the current time.

Use an implement such as a ball-point pen to press the buttons. Do not use a sharp-pointed implement that could damage the meter.

A3.2. Display and Control Buttons

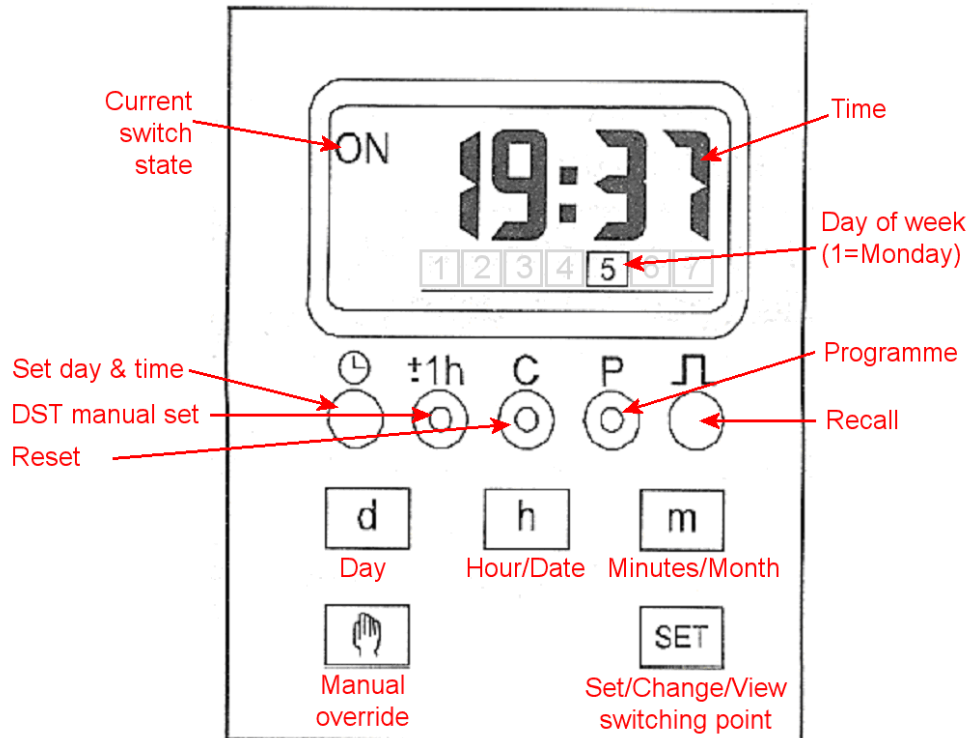

Fig A3 Timer front panel

A4. Preliminary Settings

A4.1. Initial Start-up

On a new unit or after the unit has been disconnected from the supply for some time, the display will be off and the unit must be initialised, as follows.

4. Press and hold **SET** for 5s. The display will appear after approximately 2 minutes.
5. Set the time, date etc. as detailed below.

A4.2. Time Setting

Check the displayed time. If necessary, set the time as follows:

1. Press **⌚**, The colon stops flashing.
2. Use the **d**, **h** and **m** buttons to set the day, hours and minutes.
3. Press **⌚** to save your settings.

Daylight saving time (DST) adjustments will be made automatically.

A4.3. Setting Date and Automatic Daylight Saving Time

The date must be set if you wish to use automatic daylight saving time (DST) or dusk/dawn switching functions.

1. Press **±1h** for 5 seconds: **1. 1** appears in the display.
2. Press **h** to enter day (default setting is 1).
3. Press **m** to set the month (default setting is 1).
4. Press **d** to switch to year setting (default setting is "01 ") and then press **m** to set the year (01 = 2001).
5. To save the settings WITH automatic summer/winter time adjustment, press **d**. **±1h** appears in the display.
6. To save the settings WITHOUT automatic summer/winter time adjustment press **⌚**.

A4.4. Deactivating Automatic DST Adjustment

Press **±1h** for 5 seconds, then press **⌚**. Automatic DST adjustment is deactivated and the symbol **±1h** is removed from the display..

A4.5. Manual DST Adjustment

Press the **±1h** button until the correct time is displayed.

If the symbol **±1h** appears in the display, the DST setting cannot be changed manually.

A5. Main Functions

A5.1. Setting a Switching Point

1. Press **SET**. The display shows the first ON switching point.
2. Press **d** repeatedly to obtain the required day or block of days for which this switching point will apply.
3. Press **h** to set hours for the switch-on point.
4. Press **m** to set minutes for the switch-on point.
5. Press **SET** again. The display shows the OFF time for the switched period.
6. Use the **d**, **h**, **m** buttons again to set the day(s) hours and minutes for the switch-off point.
7. Press the **SET** button again to confirm your setting. The next switching point will be displayed.
8. Repeat the procedure as necessary to set more switching points.
9. Press  to exit the routine.

The current time is displayed again after 60 seconds or when  is pressed.

A5.2. Changing a Switching Point

1. Press **SET** repeatedly until the desired switching point appears in the display.
2. Set the new times as described in *Section A5.1. Setting a Switching Point*.

The current time is displayed again after 60 seconds or when  is pressed.

A5.3. Deleting a Switching Point

1. Press **SET** repeatedly until the desired switching point appears in the display.
2. Press **h** repeatedly until **--:--** appears in the display.
3. Press **SET**. The switching point is deleted and the next switching point is displayed.

The current time is displayed again after 60 seconds or when  is pressed.

A5.4. Manual and permanent switching

Repeated pressing of  displays the following operating modes:

- Automatic off (**OFF**),
- Automatic on (**ON**),
- Permanent off (**OFF FIX**),
- Permanent on (**ON FIX**).

With the Permanently On (**ON FIX**) or Off (**OFF FIX**) settings, the stored program will be bypassed without the loss of program values.

The current time is displayed again after 60 seconds or when  is pressed.

A6. Special Functions

A6.1. Deactivating Individual Switching Points

Recall the switching point by pressing **SET** and deactivate it by pressing the  button. **[1]** is displayed above the colon. This switching point remains inactive until it is reactivated.



To reactivate a switching point, recall the switching point by pressing **SET**, then press : **[]** appears in the display above the colon.

The current time is displayed again after 60 seconds or when  is pressed.

A6.2. Holiday switching

This function enables the switching channels to be set permanently ON or OFF for a maximum period of up to 99 days without affecting the switching points programme.



Holiday switching is not possible in ON FIX and OFF FIX (permanent) switching modes. This is indicated by the symbol **FIX** flashing on the display.



1. Press the  button for five seconds until **0.d** appears on the display. Press  repeatedly until the desired number of holiday days appears in the display.
2. Press  to set the desired switching mode OFF or ON.

Do not press any other button after this, or the holiday switching mode will be deactivated.

When the set holiday period has expired, the time switch resets automatically to the normal display.

A6.3. Random Switching Points

The actual switching time can be varied in a random fashion about the set time within a time frame of $\pm 1-59$ minutes. To set random timing for a switching point, select the switching point using the **SET** button and then press . The symbol  appears, showing that the precise time of switching will be selected at random.

To set the range of fluctuation, press  and then press **SET** eight times. **[3]** is displayed. Use the  button to select the required range between ± 1 and ± 59 minutes. See Table A1(9).

A6.4. Reset button

Pressing the  button deletes the currently set clock time, day and date.

Pressing **SET** and  together deletes the currently set time, day, date and all set switching points. Settings revert to the defaults.

A6.5. Program button

The program modes are as follows:



















Item		Function	Display/ settings	Default setting
1		Pulse function (not used)	P1, P2, P3	P1
2	1x 	Dusk/Dawn Switching functions	AO, A1, A2, A3, A4, A5	AO
3	2x 	Latitude for Dusk/Dawn Switching	S 90 to N 90	n 50
4	3x 	Longitude for Dusk/Dawn Switching	E 180 to W 180	E10
5	4x 	Time zone for Dusk/Dawn Switching	t -11 to t 12	+1 for CET
6	5x 	Sun below Dusk/Dawn Switching	0° to 18°	6°
7	6x 	Morning time Dusk/Dawn Switching	-2:59 to 2:59 	0:00 h
8	7x 	Evening time Dusk/Dawn Switching	-2:59 to 2:59 	0:00 h
9	8x 	Fluctuation range of random switching points	1 to 59 	30 min
10	9x 	Cycle error	-99 to 99 	Varies

Table A1 Program functions

To select a program function, press  and then press  repeatedly to cycle through the available functions. Having selected a function, use the  and  buttons to set or select the parameters. Press  to confirm your setting. The display will show the next function in the list.

Press  to exit program mode without saving the displayed function.

A7. Pulse Function

A7.1. Pulse function P1





The Pulse function provides an option of generating a pulse at a switching point. This function, controlled by the  button, is not used in this application,

A8. Dusk/Dawn Switching Function

This function provides for switching on at dusk and off at dawn. It operates by calculating the morning and evening twilight times from the lat/long location and time of year. The twilight times can, like the entered switching points, be used to execute switching functions. The clock varies the switching times with the time of year.

A8.1. Setting a Dusk/Dawn Switching Function

The time switch provides five Dusk/Dawn Switching function A1-A5, as shown in Table A1(2). Select **A0** if Dusk/Dawn Switching is not required.

1. Press  followed by  to select Dusk/Dawn Switching. The display will show **A0**.
2. Press  repeatedly to select the desired function (A1-A5) - see *Sections A8.4. Dusk/Dawn Switching Function A1 to A8.8. Dusk/Dawn Switching Function A5*.
3. Press  to confirm your selection. The next function **Latitude** will be selected and the display will show **n xx** (North) or **S xx** (South), where **xx** is the currently set latitude.

4. Use the **m** button to set the parameter value. Press and hold the button to advance the setting in increments of 10.
5. Press **SET** to confirm your setting. The next parameter will be displayed.
6. Repeat steps 4 and 5 for each Dusk/Dawn Switching parameter, Longitude, Time zone, Sun below horizon and Morning and Evening differentials, using the **m** and **h** buttons as required.

When a Dusk/Dawn Switching function has been selected, the clock calculates the current twilight times. These are recalculated at 0:00 h on each subsequent day.

A8.2. Dusk/Dawn Switching parameters

Latitude and Longitude: The twilight times depend on the geographical position of the place of operation. The default setting is 50° north (latitude) and 10° east (longitude), corresponding roughly to the geographical position of Frankfurt/Main, Germany.

Clock zone: The standard clock zone is set for Central Europe. The value must be changed corresponding to the place of operation. (UK = 0.)

Sun below horizon: the time switch calculates the current twilight times based on the angles entered. The default setting is an angle of 6°, corresponding to "civil twilight" (nautical twilight = 12°, astronomic twilight = 18°).

Morning and evening time differential: the time differentials enable the twilight switching points to be shifted and determine the morning and evening switch-on duration (see Table A1). The setting 0:00 makes the time differentials ineffective. The time differential settings are only effective for functions A1 and A2.

A8.3. Twilight Times Display

The twilight times are stored as special switching points and can be displayed by pressing the **SET** button:

The time is displayed, the colon flashes.

The dawn switching point is displayed. Pressing **SET** again displays the dusk switching point.

The date must be entered when using the automatic Daylight Saving Time switchover and Dusk/Dawn Switching functions. If the Dusk/Dawn Switching function is deactivated (= AO), no twilight switching points are displayed.

A8.4. Dusk/Dawn Switching Function A1

In Dusk/Dawn Switching function A1, the dusk switching point acts as a switch-on point and the dawn switching point as a switch-off point.

Function A1 also allows for shifting the calculated twilight switching points. One time differential each can be set for both the dawn and the dusk switching points, enabling execution of the twilight switching points to be advanced or retarded. A negative differential value gives an earlier the switching point and a positive value gives a later switching point. See Fig A4.

Activating Dusk/Dawn Switching function A1 renders other set switching points ineffective.

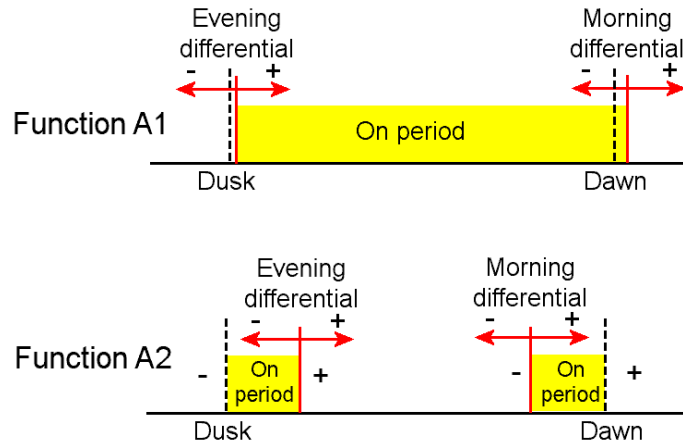

Fig A4 Functions A1 and A2

A8.5. Dusk/Dawn Switching Function A2

Function A2 enables the switching on of an item for a desired period of time after dusk or before dawn.

The period during which the light is switched on after dusk is determined by the evening time differential. The morning time differential determines the duration of switch-on time before dawn (see Fig A4).

If one of the evening or morning switching sequences is not required, set the corresponding time differential to 0:00.

Activating Dusk/Dawn Switching function A2 renders other set switching points ineffective.

A8.6. Dusk/Dawn Switching Function A3 (AND-linked)

Function A3 combines set switching points with the twilight times in an AND fashion. The switch is On only when both sources call for power. See Fig A5.

A8.7. Dusk/Dawn Switching Function A4 (OR-linked)

Function A4 combines set switching points with the twilight times in an OR fashion. The switch is On when either source calls for power. See Fig A5.

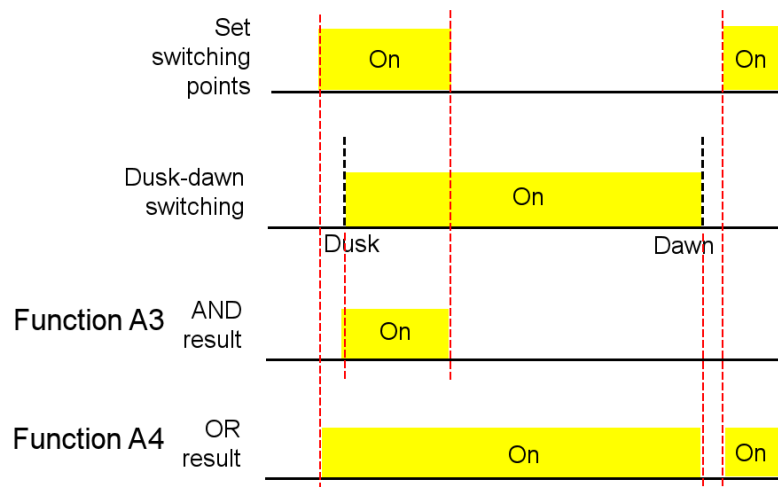

Fig A5 Functions A3 and A4

A8.8. Dusk/Dawn Switching Function A5

With Function A5, the switch comes On at the dusk switching point and off with the next switching point on the following day, not by the dawn.

Example 1	On/Off	On/Off	Example 2	On/Off	On/Off
Switching points programmed	7.00	9.00	Switching points programmed	7.00	9.00
Dusk/dawn summer	22.00 (6.00)	22.00 (6.00)	Dusk/dawn winter	18.00 (8.00)	18.00 (8.00)
Executed switching time	22.00 7.00	22.00 9.00	Executed switching time	18.00 7.00	18.00 9.00

Table A6

Further additionally entered switching points are not executed.

A9. Setting Cycle Error Correction

Cycle error correction can only be set when mains voltage is connected.

Cycle correction value: the cycle precision of the time switches at room temperature (20° C) is generally better than 1 second per day. Higher ambient temperatures, however, can cause an additional cycle error. If the ambient conditions are constant to the greatest possible extent, the error can be minimised by resetting the cycle correction value. To do this, the cycle error is determined by comparing it with a time signal (e.g. radio or television) over a period of exactly one week. The value in seconds of cycle deviation per week obtained in this manner is then taken into account when resetting the cycle correction value.

If the time switch is fast, the cycle correction value is reduced by the number of seconds. If the time switch is slow, the value is increased by the number of seconds.

The factory default setting for cycle error correction is for conditions of approx. 20°C. The newly ascertained cycle deviation must be added to or subtracted from the default value.

Example:

Default value for cycle correction: +2 sec per week

Newly ascertained cycle deviation: +3 sec per week.

3 seconds must be deducted from the default setting, i.e. -1 must appear in the display (for setting, see Table 1).

A10. Technical details

A10.9. Updating the Switching Outputs

If new switching points are entered or the current time is changed, the current switching status is re-calculated and the entered switching points are updated accordingly within 1 minute.

A10.10. Behaviour in the Case of Electrical Supply Failure

In the supply voltage is lost, the switching relay(s) will be deactivated (OFF position) and the digital display switched off.

The relays commence working again, as programmed, approximately one minute after the supply voltage has been restored.

Should the reserve power supply be exhausted following a prolonged supply failure, the switching points will be retained indefinitely but the time, day and date will have to be re-entered (see A10.11. Technical data).

A10.11. Technical data

Electrical connection	see rating plate
Internal power consumption	1W
Switching output	see rating plate
Switching contact	Single pole changeover
Number of switching points	56
Shortest switching interval	1 min. (1s for pulse programming)
Cycle accuracy	<± 1 s/day; 20°C
Reserve power supply (charging time > 1h)	>38 hours at 20°C (Supercap) 5 years (lithium battery)
Temperature limits	-10 to +50 °C
Protection category	II acc. to EN 60335 installed
Protection type	IP 20 acc. to EN 60529 installed

A11. Ignition Unit Settings

Fig A6 shows the Ignition Unit rear panel. All the dip switches, except A4, should be Off. Switch A4 should be On to ensure that the selected lights are powered when the ignition switch is set to Manual.

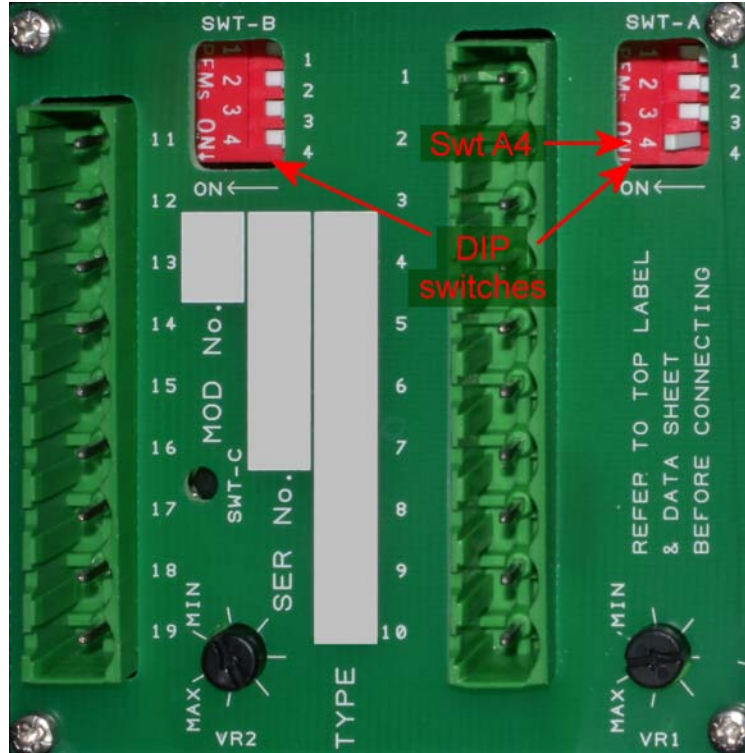

Fig A6 Capricorn Ignition Unit rear panel