

L10
L14
L18
L28
L35

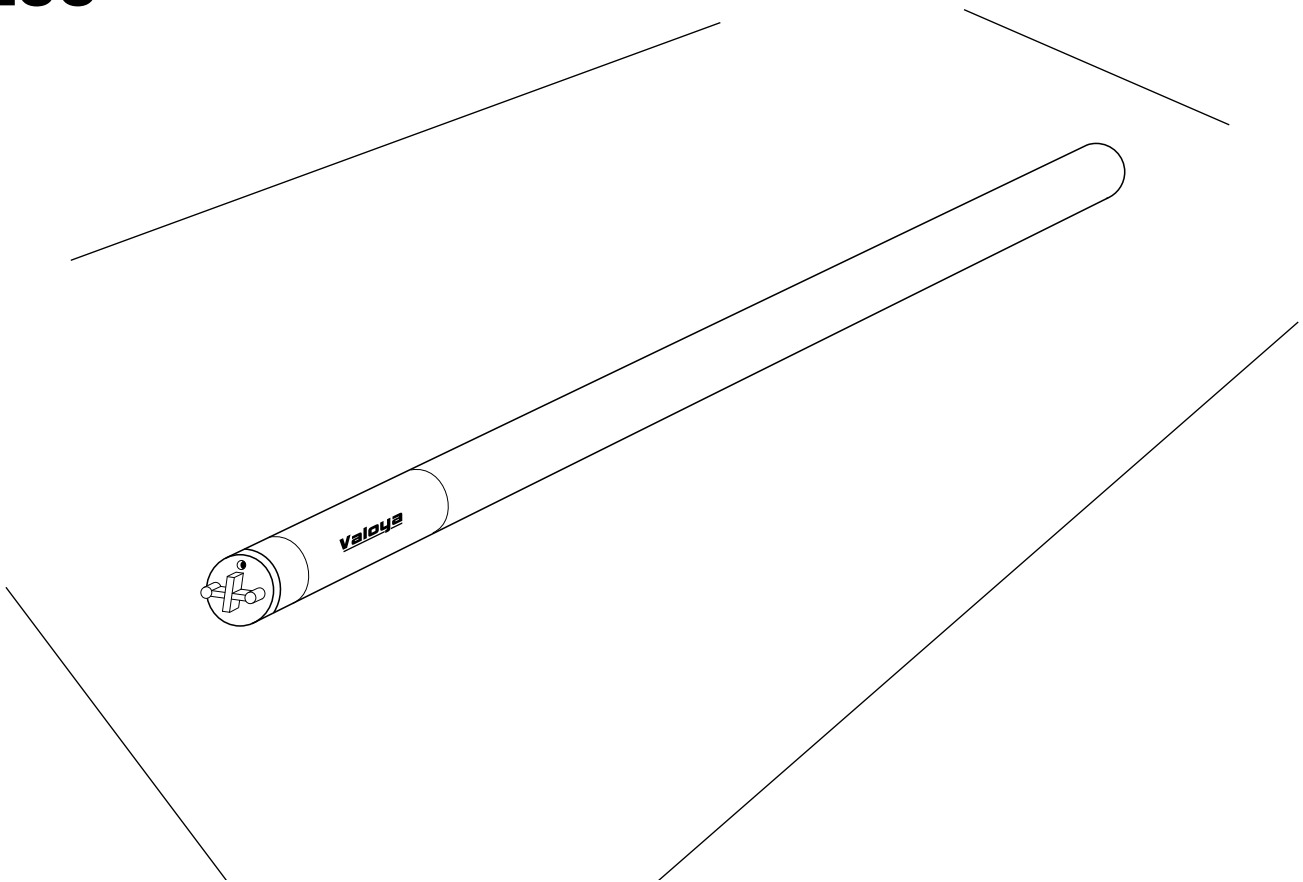



ENGLISH

CAUTION!

Inappropriate installation may cause injury to persons and damage to the lamp.

DEUTSCH

VORSICHT!

Unsachgemäße Installation kann zu Personen- und Sachschäden führen.

NEDERLANDS

LET OP!

Onjuiste installatie kan schade aan personen of de lamp veroorzaken.

PORTUGUÊS

ATENÇÃO!

A instalação inapropriada pode causar danos na luminária e ferimentos nas pessoas.

ESPAÑOL

PELIGRO!

Una instalación inadecuada puede provocar lesiones o dañar la lámpara.

VLAAMS

LET OP!

Verkeerde aansluiting kan schade veroorzaken aan de lamp of leiden tot lichamelijk letsel aan personen.

FRANÇAIS

ATTENTION!

Une mauvaise installation peut être source de blessures corporelles et endommager les lampes.

SVENSKA

AKTA!

Felaktig installation kan leda till skador på personer och lampan.

SUOMI

HUOMIO!

Valaisimen huolimaton asennus voi johtaa henkilön loukkaantumiseen ja valaisimen vioittumiseen.

РУССКИЙ

ОСТОРОЖНО!

Неадекватный монтаж может привести к серьезным травмам и повреждению лампы.

日本語

注意！

不適切な取り付けは人の傷害、およびランプの損傷の原因となる場合があります。

ITALIANO

ATTENZIONE!

L'installazione non corretta può causare lesioni alle persone e danni alla lampada.



BEFORE YOU BEGIN

THIS PRODUCT MUST BE INSTALLED BY A QUALIFIED PERSON IN ACCORDANCE WITH THE ELECTRICAL SAFETY CODES & REGULATIONS APPLICABLE IN THE COUNTRY OF INSTALLATION. THE QUALIFIED PERSON SHOULD BE FAMILIAR WITH THE CONSTRUCTION AND OPERATION OF SUCH PRODUCTS, AND THE HAZARDS INVOLVED.

- Risk of fire or electric shock; The electrical rating of these products is AC100-277V.
- Risk of fire or electric shock; Installation requires prior knowledge of fluorescent lighting luminaires and electrical systems. If not qualified, do not attempt installation and contact a qualified electrician.
- Risk of fire or electric shock; Install only in luminaires that have the construction features and dimensions shown in the drawings.
- To prevent wiring damage or abrasion, do not expose wiring to edges of sheet metal or other sharp objects.
- Do not make or alter any holes in a wiring enclosure or other electrical components during product installation.
- Suitable for use with non-shunted G13 lamp holders only.
- Please note that the supply input for the Valoya LED tube is only at the end where the product label is situated. The input end is clearly indicated on the product label.
- Not Dimmable! Warranty void if used with a dimmer.
- Keep away from Children. Contains small parts, such as the end cap protector.
- Not for use in totally enclosed luminaires.
- Once fitted with a Valoya LED tube a retrofitted luminaire can no longer be used with a conventional fluorescent tube. The installer shall ensure the retrofitted luminaire is clearly marked to indicate this in a location visible by the user during normal maintenance, including re-lamping.

THE RETROFIT ASSEMBLY IS ACCEPTED AS A COMPONENT OF A FLUORESCENT LUMINAIRE WHERE THE SUITABILITY OF THE COMBINATION SHALL BE DETERMINED BY UL OR AUTHORITIES HAVING JURISDICTION.

IMPORTANT

Installation must be carried out by qualified persons, and according to the electrical safety rules & regulations applicable in your country!

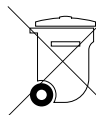

RoHS

PATENTS APPLY





DELIVERY CHECK

- Please inspect the goods upon receipt to ensure that your delivery is complete.
- If you detect any damage to the packaging, please notify the carrier immediately and ask them to note that “the delivery was not delivered in good condition”.
- If the packaging shows no damage but the goods inside are either missing, defective, or show other signs of damage, please contact us.
- In all cases please take pictures as evidence and contact us as soon as possible by phone or e-mail.

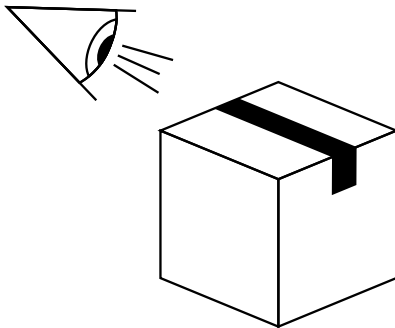

Check package

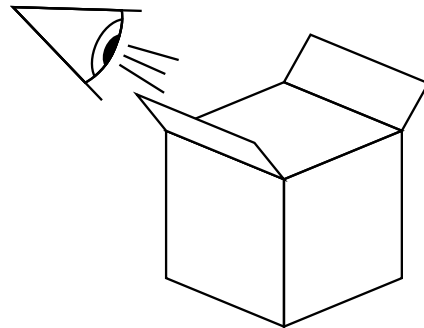

Check content

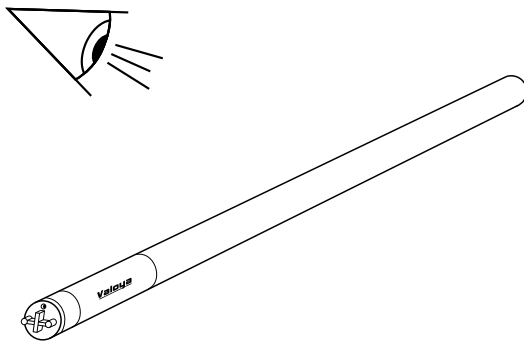

Check operation

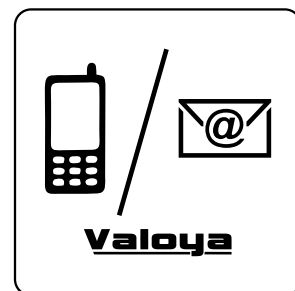

If problems, contact us



PART IDENTIFICATION

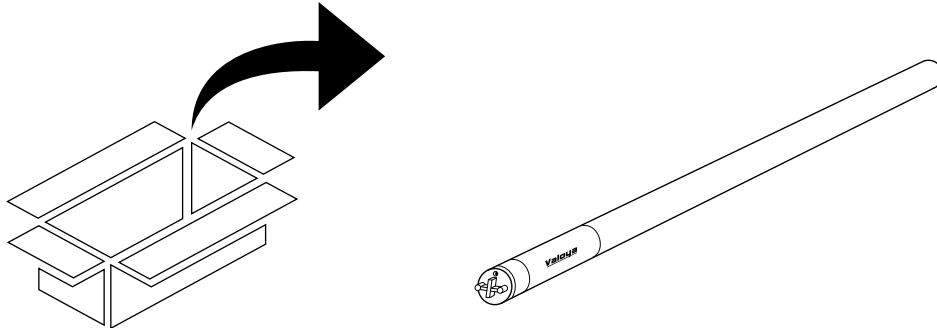

Optional Parts (Ordered separately)

(A)

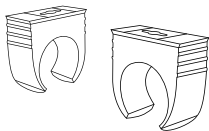

(B)



(C)

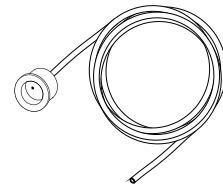

(D)

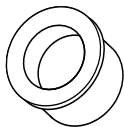

(E)

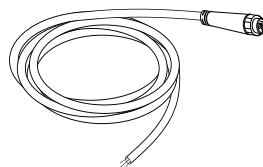

(F)

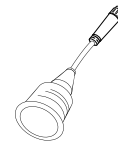

(G)

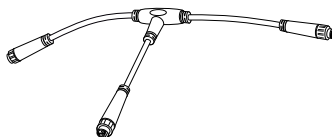

(H)



(I)



- (A) Clips (pair)
- (B) Fake starter (retrofit applications only)
- (C) Mains lead (3m, IP64)
- (D) Blank end cap (IP64)

Chainable components

- (E) 3m mains input cable (open ends)
- (F) (IP64)
- (G) End cap (IP64)
- (H) T-connector (IP64)
- (I) 0.5m connection cable (IP64)
- 1m connection cable (IP64)



SPECIFICATIONS (TYPICAL)		L10	L14	L18	L28	L35
Electrical	Total Power (W)	10	14	18	28	35
	Input voltage, nominal	100 - 240, 277				
	Input current (A)	0.04 - 0.09	0.05 - 0.13	0.07 - 0.16	0.10 - 0.25	0.13 - 0.32
	Frequency (Hz)	50 / 60				
	Power Factor	> 0.95				
	Dimmable (IEC 60929 Annex E)	No				
	AC mains plug fitted	No				
16A Type-C MCB load (max.@ 230 VAC)*	300	200	150	100	80	
Physical	Length, lamp only (mm/in)	595 / 23.4	895 / 35.2	1198 / 47.2	1198 / 47.2	1498 / 59
	Diameter, lamp only (mm/in)	26	26 /1.02	26 /1.02	26 /1.02	26 /1.02
	Weight, lamp only (mm/in)	0.22 / 0.49	0.29 / 0.64	0.36 / 0.79	0.36 / 0.79	0.44 / 0.97
	Lamp cap	G13				
	Recommended distance from plants (mm/in)	< 500 / 20	< 500 / 20	< 500 / 20	< 500 / 20	< 500 / 20
Optical	Efficiency, 380-820nm (PPF)	Up to 2.1 µmol/W (Spectrum dependent)				
	Photon Flux (PF); Full spectrum	Up to 21 µmol/s	Up to 29 µmol/s	Up to 38 µmol/s	Up to 60 µmol/s	Up to 74 µmol/s
	Light intensity decay, Q90 / L90 (hours)	35000				
	Typical use life, Q70/ L70 (hours)	50000				
Environmental	Operational ambient temperature range (°C/°F)	-10...+40 / +14...+104				
	Maximum Relative Humidity (%)	90 (non-condensing)				
	Storage temperature (°C/°F)	-20...+40 / -4...+104				
	Ingress Protection (IP) rating	IP20 (Lamp only). IP64 with optional end-cap				
Packaging	Pieces per box (luminaire)	12	12	12	12	12
	Box length (mm/in)	730 / 29	1030 / 41	1330 / 53	1330 / 53	1630 / 64
	Box width (mm/in)	170 / 6.7	170 / 6.7	170 / 6.7	170 / 6.7	170 / 6.7
	Box height (mm/in)	170 / 6.7	170 / 6.7	170 / 6.7	170 / 6.7	170 / 6.7
	Box weight (kg/lb)	3.3 / 7.2	4.0 / 8.8	5.1 / 11.2	5.1 / 11.2	6.1 / 13.4
Regulations	CE marked	X				
	RoHS compliant	X				
	EMC directive compliant	X				
	Low Voltage Directive compliant	X				
	Eco-design (EuP) directive compliant	X				
	Certified to UL & CSA standards	x	No	No	x	x

* If using Valoya chainable end caps the maximum quantity is reduced (due to cable rating). A 10A MCB is the maximum permissible. For quantities, please refer to the table in the chainable end cap section of this guide.

Notes:

- Electrical values are typical nominal figures (variations may occur due to spectrum, component & production tolerances).
- Due to our continuous program of product development, specifications are subject to change without notice in order to improve spectra, function, performance & reliability.
- Due to manufacturing tolerances, slight variations are possible in cable lengths, weights & package dimensions.





Installation with end-cap-set **with IP64**

1

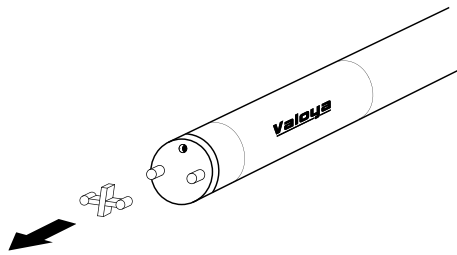

2

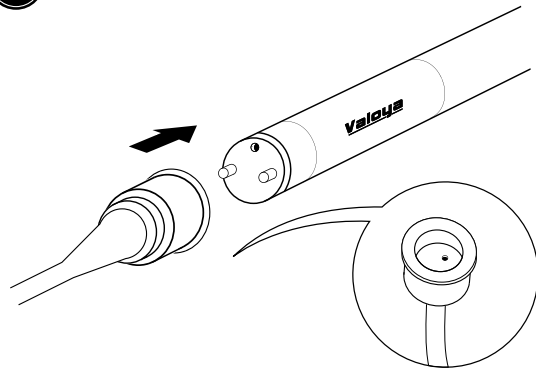

3

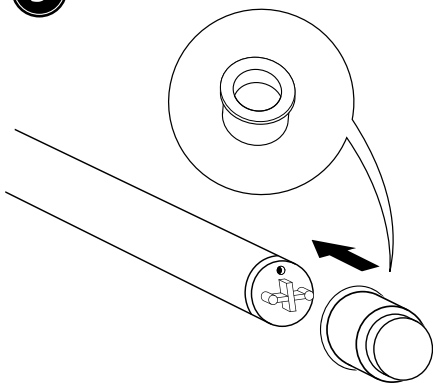

4

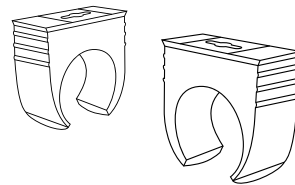

5

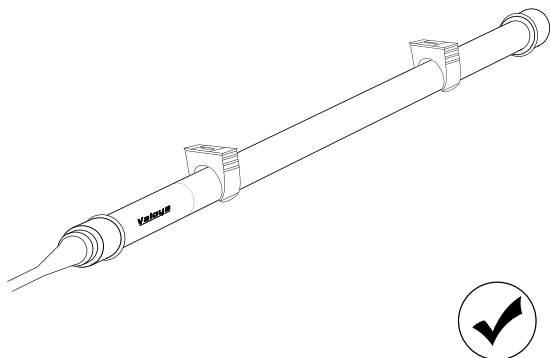



Installation with chainable end-cap-set, **IP64**

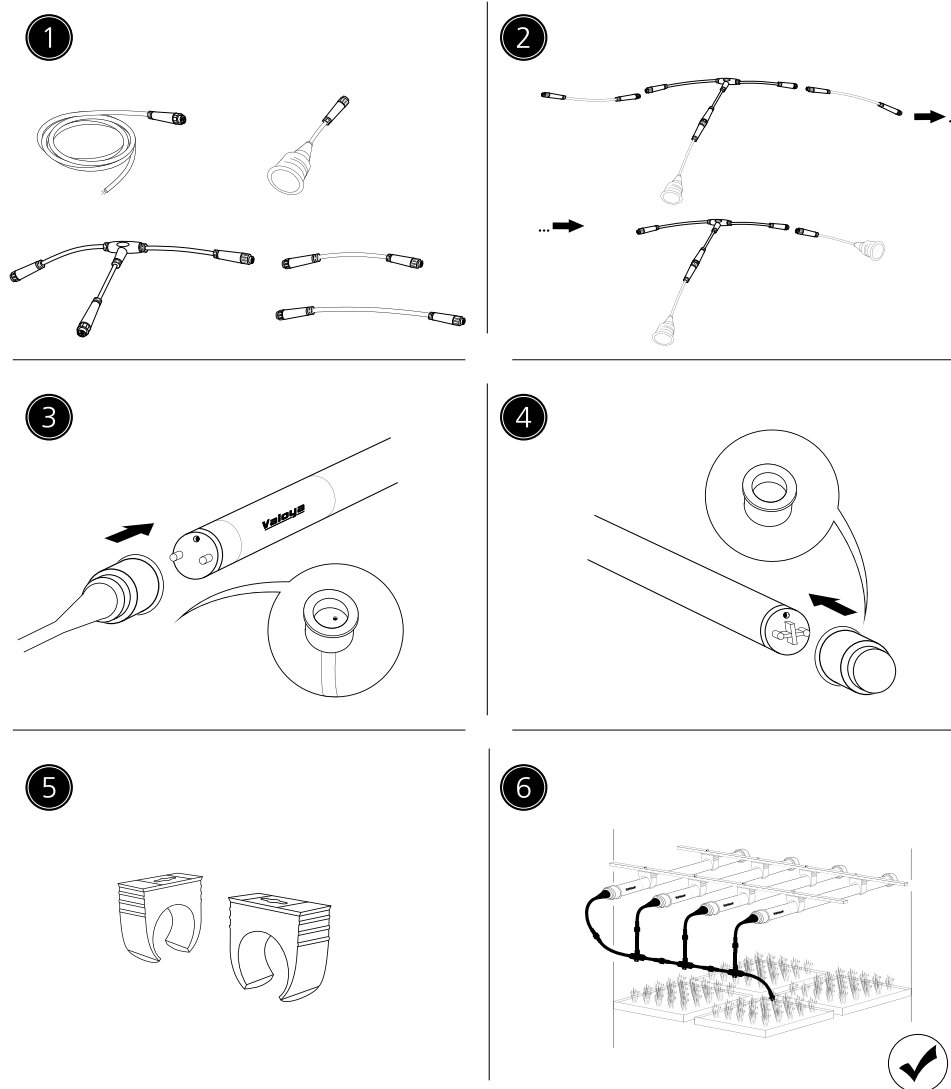

CHAINABLE END-CAPS

The number of fixtures that can be connected in a chain with a single mains input is limited and depends on the fixture model. Please refer to the table below to see maximum number of fixtures per model.

Nominal supply voltage (VAC)	Maximum number of end-caps in a single chain:						Series
	L10	L14	L18	L28	L35	Quantity	
120	75	54	42	27	21		
208	131	93	72	46	37		
230	144	103	80	51	41		
240	151	108	84	54	43		
277	174	124	96	62	49		





MAGNETIC BALLAST INSTALLATION

1

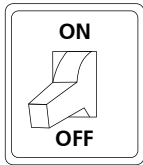

2

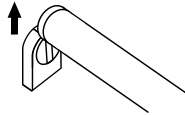

3

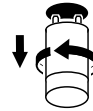

Valoya LED starter

4

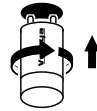

5

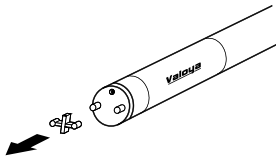

6

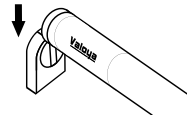

7

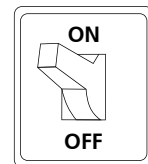

Electronic ballast installation (remove ballast). Only a qualified electrician can make modification to the luminaire.

1

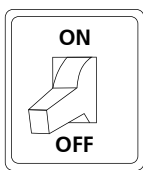

2

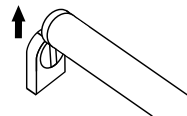

3

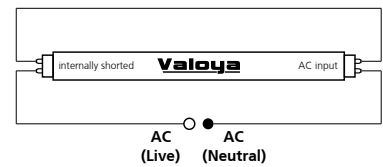

4

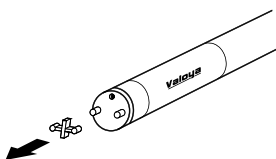

5

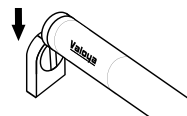

6

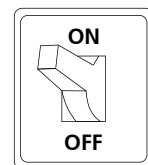



IMPORTANT

Installation must be carried out by qualified persons, and according to the electrical safety rules & regulations applicable in your country!

INSTALLATION INSTRUCTION

- Switch off the light and disconnect the related mains fuse.
- Secure the mains switch/fuse against accidental reconnection.
- For retrofit applications, remove the original fluorescent tube from the luminaire.
- For fluorescent luminaires containing a magnetic ballast, remove the existing starter and insert a “Valoya Starter”.
- For fluorescent luminaires containing an electronic ballast, rewire as shown in the relevant diagram below. Note that any needed rewiring must be carried out by a qualified person.
- Take the Valoya LED tube and remove the white protection caps from the pins on both ends.
- Insert the Valoya LED tube into the luminaire ensuring the label is at the end of the luminaire where the mains supply will be present at the G13 lamp holder.
- Turn the Valoya LED tube 90 degrees (LEDs are directed downwards).
- Reconnect the main fuse.
- Switch on luminaire on.

Direct connection to a G13 lamp holder

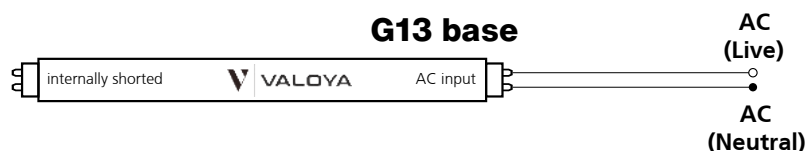

Retrofitting in fluorescent magnetic ballasted luminaires

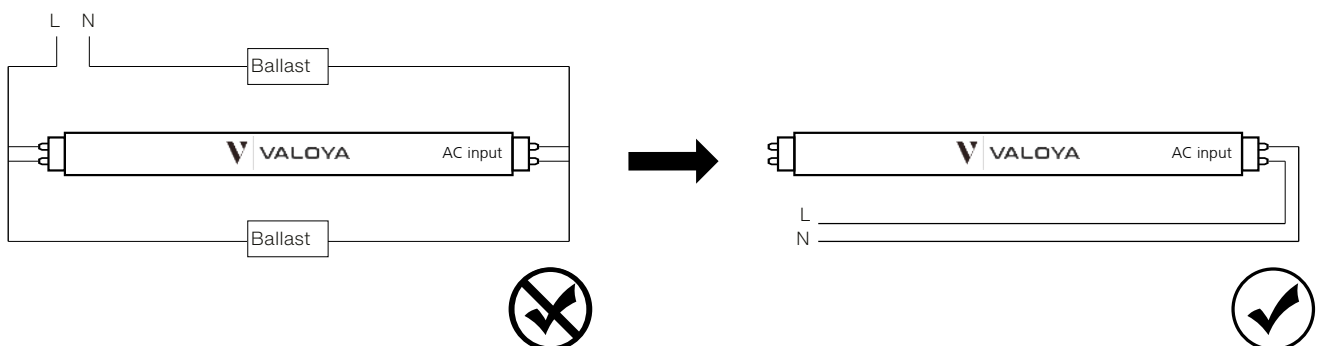



Retrofitting in fluorescent magnetic ballasted luminaires

Retrofitting a luminaire with one lamp

(example only; Note that the original ballast connections may vary depending on manufacturer)

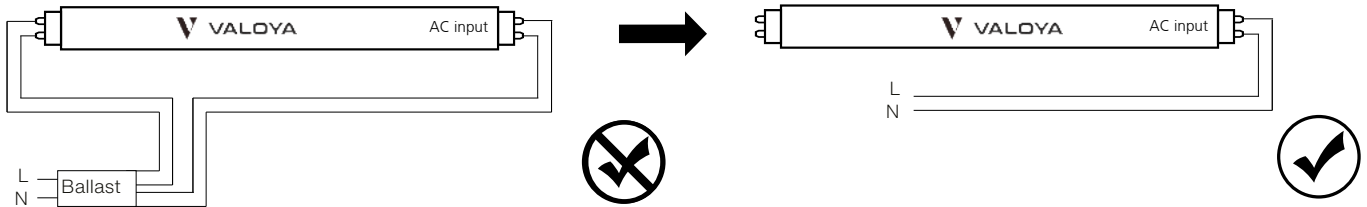

Retrofitting a luminaire with two lamps and one ballast

(example only; Note that the original ballast connections may vary depending on manufacturer)

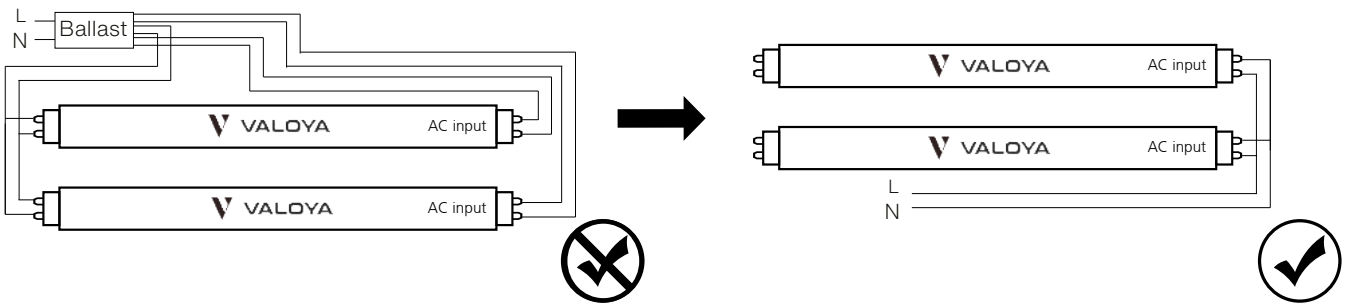

Retrofitting a luminaire with more than two lamps

(example only; Note that the original ballast connections may vary depending on manufacturer)

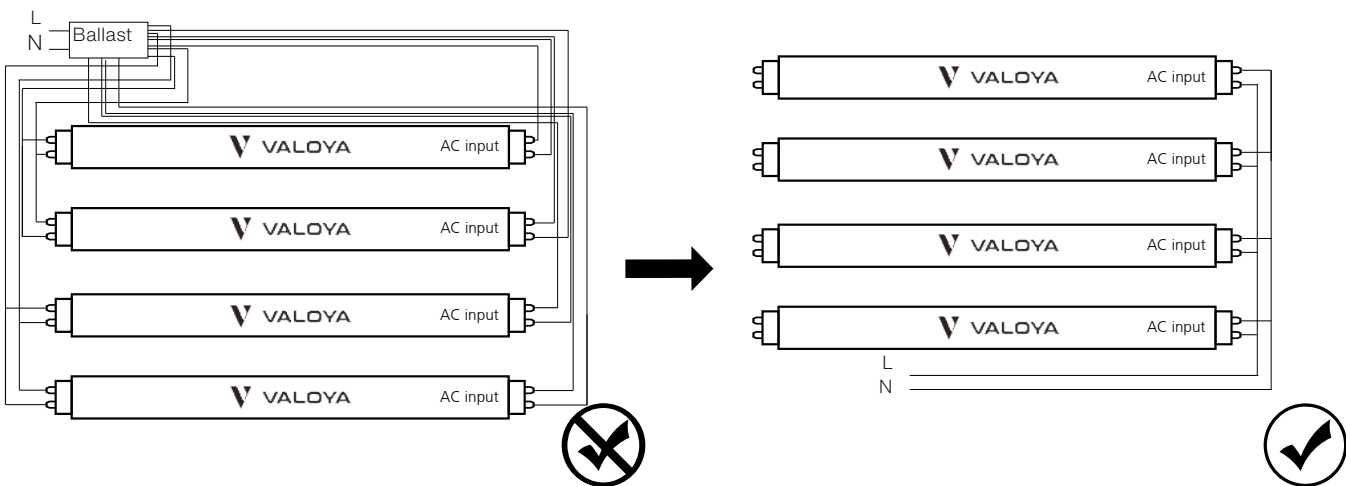

T8 TUBES INTENDED TO BE RETROFITTED: MAXIMUM NUMBER IN ORIGINAL LUMINAIRE

Luminaire dimension with the maximum number of tubes L x W x H (cm)

Max. 4pcs 1500mm LED tubes can be operated in a luminaire with or without diffuser

150 x 60 x 8

Max. 4pcs 1200mm LED tubes can be operated in a luminaire with or without a diffuser

120 x 60 x 8





INRUSH CURRENT

This is the initial current surge drawn during product start-up. Total inrush current rises as the circuit load increases and is one factor that can contribute to nuisance tripping of circuit breakers (MCB's). Practical performance will be affected by the MCB load, MCB tripping characteristics, site wiring impedance, and the angle of the AC mains cycle at the specific moment power is applied.

Nuisance tripping issues may be improved by:

- Reducing the quantity of LED drivers connected to a single MCB.
- Re-distributing the load over multiple mains phases.
- Using an MCB with Type C (EN 60898) tripping characteristics.
- Installing additional inrush current limiting devices.
- Installing a zero crossing relay for powering up the LED drivers.

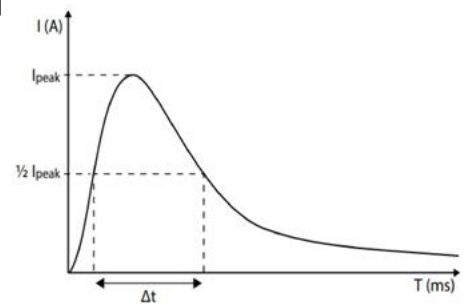

Example of a typical inrush current graph

MCBS (MINIATURE CIRCUIT BREAKERS)

Valoya only recommend using MCB's with "Type C" trip characteristics according to EN 60898.

The maximum quantity of Valoya products recommended for a 16A Type C MCB is stated on the product's technical specifications datasheet (e.g installation guide). This quantity is used as the 100% reference in the table below. The table is provided as a tool to enable calculation of the approximate maximum load for different MCB types and ratings. Installation wiring rating, impedances and mains switch-on angle variations may also influence the actual practical limit.

20A branch circuit is the maximum allowed per UL certification according to LED Drivers UL Conditions of Acceptability.

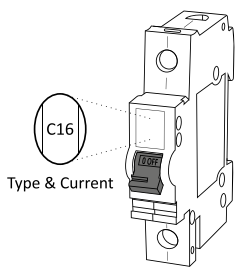

MCB example

MCB TYPE	Rating (A)	Relative quantity (%)
B	10	37
	16	60
	20	75

MCB TYPE	Rating (A)	Relative quantity (%)
C	10	62
	16	100 (Ref.)
	20	125

ICL (INRUSH CURRENT LIMITER)

An ICL can help avoid nuisance MCB tripping and can be installed between the MCB and the load. It also enables an increase the luminaire quantity up to the maximum RMS current limit of the Inrush Current Limiter.

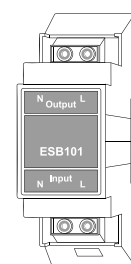

ICL example



RCDS (RESIDUAL CURRENT DEVICES)

An RCD is a protective safety device used to automatically disconnect the electrical supply when an imbalance is detected between live conductors. Requirements for use, and the needed RCD rating, will vary depending on the type of installation. Valoya luminaires are designed to be installed in fixed electrical installations where no plug is permitted for connecting the luminaire to the mains supply.

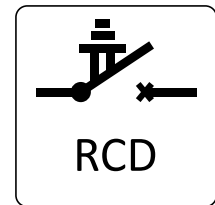

SURGE PROTECTORS

Valoya LED drivers have built-in surge protection. However, to protect against surge peaks above 4KV (e. g. Due to a lightning strike) we recommend the installation of transient voltage surge suppression.

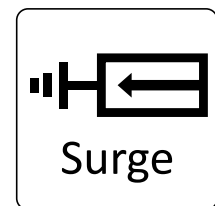

3-PHASE SUPPLIES

- Do not apply power without the Neutral connected.
- Ensure the supply is off before disconnecting the Neutral.
- To avoid erratic dimming or possible product damage, do not connect the same dimmer or controller to luminaires supplied by different mains phases.

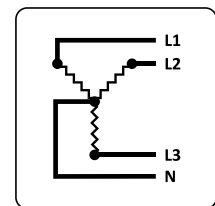

INSULATION RESISTANCE/ ELECTRIC STRENGTH TESTING

- Valoya products have been fully tested during manufacture. There is no need to test again.
- If the electrical site wiring must be tested, test with the luminaires and LED drivers disconnected from the mains supply.
- If luminaires and LED drivers are connected to the mains supply during the test, all Live phases and Neutral must be connected together before the test is carried out (Remember to check correct reconnection before reapplying the mains supply).

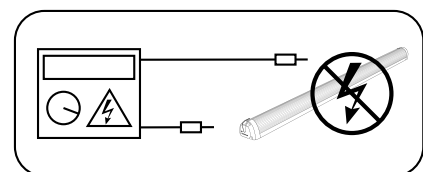



CLEANING

Switch the supply OFF

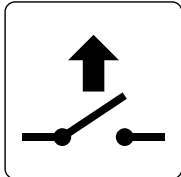

Allow to cool

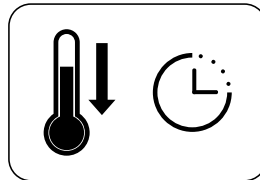

Do not use detergent



Clean with a soft brush



Wipe with soft clothes



Suitable for spray cleaning with water

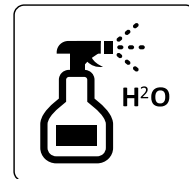



WARRANTY

Products are covered by a limited warranty. Warranty starts from date of installation, but latest 3 months from the delivery date.

The warranty offered is “Return-to-Base”, meaning suspected faulty items shall be returned to Valoya for fault and warranty validation before any repair or replacement can be agreed.

Valoya warrants that each Product will be free from defects in material and workmanship for the duration of the warranty period as long as the products are installed and used in accordance with our published specifications and recommendations.

Warranty shall be void in the event any repairs or alterations not duly authorized by Valoya in writing are made to the Product by any person.

CLAIMS

Before returning a suspected faulty item, please contact Valoya (www.valoya.com/support) to give details of the issue and obtain a Return Material Authorization (RMA) reference number. Please be prepared to provide the following information about the issue:

- Product model information (e.g. B200 NS1).
- Product serial number plus YF or XF code.
- Quantity showing problems.
- Detailed problem description.
- Photograph or video showing the issue (if possible).
- Installation / invoice date (if known).

After receiving an RMA number, Products should be suitably packed and the package or shipping paperwork clearly marked with the RMA number. Returns received without an RMA reference number may be rejected.

Valoya will inspect the returned items to validate fault and warranty validity. If Valoya determines to its satisfaction that warranty is valid, Valoya will repair or replace the Product with one of similar age. Where a warranty claim is justified, Valoya will pay for the return freight expenses for repaired or replaced items. Valoya reserve the right to invoice for returning Products that are not found to be defective, or do not comply with the terms of this warranty, together with associated freight, testing and handling costs.

*** Above is a summary of our warranty and claim policy. For full details please see: www.valoya.com/warranty.**



Standards applied (where applicable):**EUROPE**

EN60598-1: Luminaires. General requirements and tests.

EN60598-2-1: Luminaires. Part 2: Particular requirements. Section one – Fixed general purpose luminaires.

EN62031: LED modules for general lighting. Safety specifications.

EN 62493: Assessment of lighting equipment related to human exposure to electromagnetic fields.

EN55015: Limits and methods of measurement of radio disturbance characteristics of electrical lighting and similar equipment.

EN61547: Equipment for general lighting purposes. EMC immunity requirements.

EN61000-3-2: Electromagnetic compatibility - Limits - Limits for harmonic current emissions.

EN61000-3-3: Electromagnetic compatibility – Limits - Limits for Voltage Fluctuations and Flicker.

IEC EN 61000-4-2: Electromagnetic compatibility (EMC)- Part 4-2: Testing and measurement techniques - electrostatic discharge immunity test.

IEC EN 61000-4-3: Electromagnetic compatibility (EMC)- Part 4-3: Testing and measurement techniques - radiated, radio-frequency, electromagnetic field immunity test.

IEC EN 61000-4-4: Electromagnetic compatibility (EMC) - Part 4-4: Testing and measurement techniques - Electrical fast transient/burst immunity test.

IEC EN 61000-4-5: Electromagnetic compatibility (EMC) - Part 4-5: Testing and measurement techniques - Surge immunity test.

IEC EN 61000-4-6: Electromagnetic compatibility (EMC) - Part 4-6: Testing and measurement techniques - Immunity to conducted disturbances, induced by radio-frequency fields.

IEC EN 61000-4-8: Electromagnetic compatibility (EMC) - Part 4-8: Testing and measurement techniques - Power frequency magnetic field immunity test.

IEC EN 61000-4-11: Electromagnetic compatibility (EMC) - Part 4-11: Testing and measurement techniques - Voltage dips, short interruptions and voltage variations immunity tests.

IEC 61347-2-13: Lamp controlgear. Particular requirements for d.c. or a.c. supplied electronic controlgear for LED modules.

IEC 61347-1: Lamp controlgear - Part 1: General and safety requirements.

IEC 62384: DC or AC supplied electronic control gear for LED modules. Performance requirements.

EN62471: Photobiological safety of lamps and lamp systems.

EN62560: Self-ballasted LED-lamps for general lighting services by voltage >50V - Safety specifications.

EN62776: Double-capped LED lamps designed to retrofit linear fluorescent lamps - Safety specifications.

NORTH AMERICA

UL1598: Luminare safety.

UL8750: Light Emitting Diode (LED) equipment for use in lighting products.

UL2108: Standard for Low Voltage Lighting Systems.

UL 8800: Outline of Investigation for Horticultural Lighting Equipment

CSA C22.2: #9.0: General Requirements for Luminaires.

CSA C22.2: #250.0.8: Safety for Light emitting diode (LED) equipment for lighting applications.

CSA C22.2 No. 250.13-14: Light Emitting Diode (LED) equipment for use in lighting products.

Contact:

Melkonkatu 26,
00210 Helsinki,
Finland

T +358 10 2350 300

E sales@valoya.com

W www.valoya.com

Distributor list can be found at:

www.valoya.com/contact

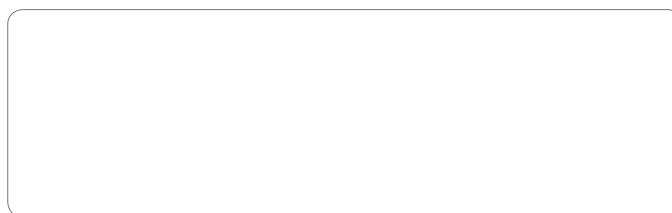

Valoya® is a registered trademark of Valoya Oy in the European Community, the USA and certain other countries.

Due to our continuous program of product development, data is subject to change without notice.