



**Alphamin Resources Corp.
Bisie Tin Project**

NI 43-101 Technical Report – 23 March 2017 Updated Feasibility Study and Control Budget Estimate Report

**Prepared By:
The MSA Group; and
DRA Projects**

**For:
Alphamin Resources Corp.**

Qualified Persons:

Jeremy C Witley

John Anthony Cox

Mark Creswell

BSc (Hons), MSc (Eng.), FGSSA, Pr. Sci. Nat.

BSc.Eng.(Mining), FSAIMM, ECSA Pr.Eng

BSc (Eng),FSAIMM, MIMMM, Pr.Eng

Effective Date: 6 February 2017

Report Date: 23 March 2017

IMPORTANT NOTICE

This report was prepared as a National Instrument 43-101 Technical Report by The MSA Group and DRA Projects for Alphamin Resources Corp. The quality of information, conclusions and estimates contained herein is based on: i) information available at the time of preparation, ii) data supplied by outside sources, and iii) the assumptions, conditions, and qualifications set forth in this report. This report is intended for use by Alphamin Resources Corp. Except for the purposes legislated under Canadian provincial securities law, any other uses of this report by any third party is at that party's sole risk.



The MSA Group (Pty) Ltd
Registration No: 2000/002800/07
Tel: +27 (0)11 880 4209 | Fax: +27 (0)11 880 2184
email: info@msagroupservices.com
20B Rothesay Avenue, Craighall Park, Johannesburg 2196
PO Box 81356, Parkhurst, 2120, South Africa
Directors: KD Scott, WSM Majola

Specialist Consultants to the Mining Industry

CERTIFICATE OF QUALIFIED PERSON

I, Jeremy Charles Witley do hereby certify that:

1. I am Principal Resource Consultant of:
The MSA Group (Pty) Ltd
Henley House
Greenacres Office Park
Victory Park, Gauteng, South Africa,
2195
2. This certificate applies to the technical report titled "Alphamin Resources Corporation, Bisie Tin Project, North Kivu Province, Democratic Republic of the Congo – NI 43-101 Technical Report – 23 March Updated Feasibility Study and Control Budget Estimate Report", that has an effective date of 6 February 2017 and a report date of 23 March 2017 (the Technical Report).
3. I graduated with a BSc (Hons) degree in Mining Geology from the University of Leicester in 1988. In addition, I obtained a Master of Science degree in Engineering from the University of Witwatersrand in 2015.
4. I am a registered Professional Natural Scientist (Geological Science) with the South African Council for Natural Scientific Professions (SACNASP) and a Fellow of the Geological Society of South Africa.
5. I have worked as a geologist for a total of 28 years. I have worked in a number of roles, including senior management, in mine geology, exploration projects and Mineral Resource management. I have conducted Mineral Resource estimates, audits and reviews for a wide range of commodities and styles of mineralization.
6. I have read the definition of "Qualified Person" set out in National Instrument 43-101 (NI 43-101) and certify that by reason of my education, affiliation with a professional association (as defined in NI 43-101) and past relevant work experience, I fulfil the requirements to be a "Qualified Person" for the purposes of NI 43-101.
7. I visited the Bisie Property during the period 18 – 20 July 2013, 20 – 22 May 2014 and 11 - 13 August 2015.
8. I am responsible for the preparation of items 1.2, 7 to 12 inclusive and item 14 of the technical report.
9. I have not had prior involvement with the property that is the subject of the Technical Report.
10. I am not aware of any material fact or material change with respect to the subject matter of the Technical Report that is not reflected in the Technical Report, the omission to disclose which makes the Technical Report misleading.
11. I am independent of the issuer according to the definition of independence described in section 1.5 of National Instrument 43-101.
12. I have read National Instrument 43-101 and Form 43-101F1 and, as of the date of this certificate, to the best of my knowledge, information and belief, those portions of the Technical Report for which I am responsible have been prepared in compliance with that instrument and form.
13. I consent to the filing of the Technical Report with any stock exchange and other regulatory authority and any publication by them for regulatory purposes, including electronic publication in the public company files on their websites accessible by the public, of the Technical Report.

Dated this 23rd Day of March, 2017.

"Signed and stamped"

Jeremy Charles Witley, BSc (Hons), MSc (Eng.), Pr.Sci.Nat. FGSSA

CERTIFICATE OF QUALIFIED PERSON

I, Gordon Mark Cresswell do hereby certify that:

1. I am an employee of:
DRA Projects (Pty) Ltd
DRA Minerals Park
Inyanga Close
Sunninghill
2157
2. This certificate applies to the technical report titled "NI 43-101 Technical Report – 23 March 2017 Updated Feasibility Study Report ", (the Technical Report).
3. I graduated with a BSc (Eng) degree in Minerals Technology from the Royal School of Mines, Imperial College, London University in 1977 and obtained an MSc in Mineral Production Management in 1984 also from the Royal School of Mines.
4. I am a Fellow of the South African Institute of Mining and Metallurgy, a corporate Member of the UK Institution of Materials, Minerals and Mining, and a registered Professional Engineer with the Engineering Council of South Africa.
5. I have worked as a minerals processing engineer for a total of 39 years. I have worked in a number of roles, including process engineer, commissioning engineer and process consultant for minerals processing testwork development, studies and projects. I have worked on studies and projects which incorporate a wide range of commodities, processes and styles of mineralization.
6. I have read the definition of "Qualified Person" set out in National Instrument 43-101 (NI 43-101) and certify that by reason of my education, affiliation with a professional association (as defined in NI 43-101) and past relevant work experience, I fulfil the requirements to be a "Qualified Person" for the purposes of NI 43-101.
7. I have not visited the Bisie Property.
8. I am responsible for the preparation of Sections 1.4, 2, 3, 13, 17, 21, 22, 25-27 of the Technical Report.
9. I have reviewed Sections 1.1, 1.6, 1.7, 1.8, 1.9, 1.10, 1.11, 18, 19 and 24 of the Technical Report.
10. I have not had prior involvement with the property that is the subject of the Technical Report.
11. I am not aware of any material fact or material change with respect to the subject matter of the Technical Report that is not reflected in the Technical Report, the omission to disclose which makes the Technical Report misleading.
12. I am independent of the issuer according to the definition of independence described in section 1.5 of National Instrument 43-101.
13. I have read National Instrument 43-101 and Form 43-101F1 and, as of the date of this certificate, to the best of my knowledge, information and belief, those portions of the Technical Report for which I am responsible have been prepared in compliance with that instrument and form.
14. I consent to the filing of the Technical Report with any stock exchange and other regulatory authority and any publication by them for regulatory purposes, including electronic publication in the public company files on their websites accessible by the public, of the Technical Report.

Dated this 20th Day of March, 2017.

"signed"

Gordon Mark Cresswell, MSc (Eng.), FSAIMM, MIMMM, Pr Eng

Dated this 23rd day of March 2017

CERTIFICATE OF QUALIFIED PERSON

I, J. A. Cox do hereby certify that:

1. I am an associate of:
Royal HaskoningDHV,
Building No 5,
Country Club Estate,
22 Woodlands Drive, Woodmead,
Gauteng, South Africa.
2. This certificate applies to the technical report titled "NI 43-101 Technical Report – 23 March 2017 Updated Feasibility Study and Control Budget Estimate Report ", that has an effective date of 23 March 2017.
3. I graduated with a Degree in Mining Engineering from the Royal School of Mines, London University in the United Kingdom in 1961.
4. I am a Fellow of the South African Institute of Mining and Metallurgy and a Professional Engineer of the Engineering Council of South Africa (ECSA).
5. I have worked as a mining engineer for a total of 55 years. I have worked in a number of roles, including mining operations, mining projects and mining consulting. I have conducted mining reviews for a wide range of commodities, mining methods and styles of mineralization.
6. I have read the definition of "Qualified Person" set out in NI 43-101 and certify that by reason of my education, affiliation with a professional association (as defined in NI 43-101) and past relevant work experience, I fulfil the requirements to be a "Qualified Person" for the purposes of NI 43-101.
7. I have visited the Bisie Property from the 28th to 30th July 2016.
8. I am responsible for the preparation of Sections 15 and 26 of the Technical Report.
9. I have reviewed Sections 16, 19, 21, 22, 23, 24 and 25-27 of the Technical Report.
10. I have not had prior involvement with the property that is the subject of the Technical Report.
11. I am not aware of any material fact or material change with respect to the subject matter of the Technical Report that is not reflected in the Technical Report, the omission to disclose which makes the Technical Report misleading.
12. I am independent of the issuer according to the definition of independence described in section 1.5 of National Instrument 43-101.
13. I have read National Instrument 43-101 and Form 43-101F1 and, as of the date of this certificate, to the best of my knowledge, information and belief, those portions of the Technical Report for which I am responsible have been prepared in compliance with that instrument and form.
14. I consent to the filing of the Technical Report with any stock exchange and other regulatory authority and any publication by them for regulatory purposes, including electronic publication in the public company files on their websites accessible by the public, of the Technical Report.

Dated this 23rd Day of March, 2017.

"signed"

J A Cox

Royal HaskoningDHV

TABLE OF CONTENTS

1	SUMMARY	14
1.1	PROPERTY DESCRIPTION & OWNERSHIP	14
1.2	GEOLOGY AND MINERAL RESOURCES	14
1.3	MINERAL RESERVE ESTIMATE	17
1.4	MINERAL PROCESSING AND METALLURGICAL TEST WORK	18
1.5	ENVIRONMENTAL STUDIES, PERMITTING AND SOCIAL COMMUNITY IMPACT	19
1.6	SITE & INFRASTRUCTURE	20
1.7	CAPITAL COST ESTIMATE	21
1.8	OPERATING COST ESTIMATE	23
1.9	ECONOMIC ANALYSIS	24
1.10	CONCLUSIONS	25
1.11	RECOMMENDATIONS	25
2	INTRODUCTION	26
2.1	SCOPE OF WORK	26
2.2	PRINCIPAL SOURCES OF INFORMATION	26
2.3	QUALIFICATIONS, EXPERIENCE AND INDEPENDENCE	27
2.4	CURRENCY	28
3	RELIANCE ON OTHER EXPERTS	29
4	PROPERTY DESCRIPTION AND LOCATION	30
4.1	LOCATION	30
4.2	OWNERSHIP STRUCTURE	30
4.3	MINERAL TENURE, PERMITTING, RIGHTS AND AGREEMENTS	30
4.4	MINING LEGISLATION IN THE DRC	33
5	ACCESSIBILITY, CLIMATE, LOCAL RESOURCES, INFRASTRUCTURE AND PHYSIOGRAPHY. 36	
5.1	ACCESSIBILITY	36
5.2	CLIMATE AND PHYSIOGRAPHY	38
5.3	LOCAL RESOURCES AND INFRASTRUCTURE	39
6	HISTORY	41
7	GEOLOGICAL SETTING AND MINERALIZATION	42
7.1	REGIONAL GEOLOGY	42
7.2	PROPERTY GEOLOGY	43
8	DEPOSIT TYPES	51

9	EXPLORATION.....	52
9.1	RECONNAISSANCE WORK BY MINING AND PROCESSING CONGO SPRL (2006-2008).....	52
9.2	WORK CARRIED OUT ON PR 5270.....	53
9.3	AIRBORNE GEOPHYSICAL CAMPAIGN	54
9.4	SOIL GEOCHEMISTRY	56
9.5	ROCK SAMPLE GEOCHEMISTRY	58
9.6	STREAM SEDIMENT SAMPLING	58
10	DRILLING	59
10.1	MPAMA SOUTH PROSPECT	60
10.2	MPAMA NORTH PROSPECT	62
10.3	EXPLORATION DRILLING	65
11	SAMPLE PREPARATION, ANALYSES AND SECURITY.....	66
11.1	ANALYTICAL QUALITY CONTROL AND ASSURANCE CONDUCTED BY ALPHAMIN	67
11.2	SUMMARY OF THE EXTERNAL ASSAY QAQC CHECKS	85
12	DATA VERIFICATION.....	87
12.1	INDEPENDENT CHECK SAMPLING.....	87
12.2	VISUAL VERIFICATION	88
12.3	VERIFICATION OF DRILLHOLE COLLARS	89
12.4	SUMMARY OF THE DATA VERIFICATION.....	89
13	MINERAL PROCESSING AND METALLURGICAL TESTING.....	90
13.1	BACKGROUND	90
13.2	SAMPLE SELECTION	90
13.3	REVIEW OF FEASIBILITY STUDY METALLURGICAL TEST WORK	90
13.4	UPDATED FEASIBILITY STUDY AND CONTROL BUDGET ESTIMATE METALLURGICAL TEST WORK	91
14	MINERAL RESOURCE ESTIMATES	93
14.1	MINERAL RESOURCE ESTIMATION DATABASE	93
14.2	EXPLORATORY ANALYSIS OF THE RAW DATA	94
14.3	GEOLOGICAL MODELLING.....	100
14.4	STATISTICAL ANALYSIS OF THE COMPOSITE DATA.....	103
14.5	GEOSTATISTICAL ANALYSIS	109
14.6	BLOCK MODELLING	114
14.7	ESTIMATION.....	115
14.8	VALIDATION OF THE ESTIMATES	120

14.9	MINERAL RESOURCE CLASSIFICATION	124
14.10	MINERAL RESOURCE STATEMENT	127
14.11	COMPARISON WITH PREVIOUS ESTIMATES	131
14.12	ASSESSMENT OF REPORTING CRITERIA	131
15	MINERAL RESERVE ESTIMATES	137
15.1	CUT-OFF GRADE CALCULATION	137
15.2	RESOURCES CONSIDERED FOR MINING.....	137
15.3	MODIFYING FACTORS	137
15.4	PROJECT VIABILITY	138
15.5	MINERAL RESERVE STATEMENT	139
16	MINING METHODS	141
16.1	GEOLOGY AND RESOURCES	141
16.2	GEOTECHNICAL CHARACTERISATION AND DESIGN	141
16.3	GROUND WATER STUDY	159
16.4	MINING METHOD SELECTION.....	161
16.5	MINE DESIGN	161
16.6	VENTILATION.....	170
16.7	MINE SCHEDULING.....	173
16.8	UNDERGROUND MINE INFRASTRUCTURE.....	175
17	RECOVERY METHODS	179
17.1	OVERVIEW	179
17.2	TEST WORK.....	181
17.3	PROCESS DESCRIPTION	182
18	PROJECT INFRASTRUCTURE.....	186
18.1	INTRODUCTION	186
18.2	HEALTH, SAFETY AND SECURITY INFRASTRUCTURE	187
18.3	MINING INFRASTRUCTURE.....	188
18.4	ENABLING INFRASTRUCTURE.....	190
18.5	MINE RESIDUE STORAGE.....	192
18.6	WASTE CONTROLS.....	193
19	MARKET STUDIES AND CONTRACTS	194
19.1	TIN MARKET ANALYSIS	194
19.2	SUPPLY AND DEMAND BALANCE.....	197
19.3	FORECAST TIN PRICE.....	198

19.4	MARKETING CONTRACT	199
20	ENVIRONMENTAL STUDIES, PERMITTING AND SOCIAL IMPACT	200
20.1	ENVIRONMENTAL PERMITTING	200
20.2	BIOPHYSICAL ENVIRONMENT	200
20.3	SOCIO-ECONOMIC ENVIRONMENT	202
20.4	KEY PROJECT ASPECTS, ISSUES AND RISKS	206
20.5	EFFECTS OF THE PROJECT ON GLOBAL CLIMATE CHANGE	214
20.6	SUMMARY OF IMPACT FINDINGS AND RECOMMENDATIONS	215
21	CAPITAL AND OPERATING COSTS	222
21.1	CAPITAL EXPENDITURE	222
21.2	OPERATING COST ESTIMATE	229
21.3	CLOSURE PROVISION	239
22	ECONOMIC ANALYSIS	241
22.1	INTRODUCTION	241
22.2	ASSUMPTION AND EVALUATION METHODOLOGY	241
22.3	REVENUE	241
22.4	TOTAL CONSTRUCTION CAPITAL ESTIMATE	243
22.5	OPERATING COSTS	244
22.6	TAXES AND ROYALTIES	245
22.7	NET PRESENT VALUE SUMMARY	245
22.8	PAY BACK PERIOD	245
22.9	MINE LIFE	246
23	ADJACENT PROPERTIES	247
24	OTHER RELEVANT DATA AND INFORMATION	248
24.1	PROJECT EXECUTION PLAN	248
24.2	SECURITY	249
24.3	LOGISTICS	255
24.4	TAILINGS STORAGE FACILITY AND MINE RESIDUE	258
24.5	MINE CLOSURE	271
24.6	OPERATIONAL READINESS	278
24.7	RISK	281
25	INTERPRETATION AND CONCLUSIONS	292
25.1	CAUTIONS REGARDING FORWARD LOOKING INFORMATION	292
25.2	CONCLUSIONS	293

26	RECOMMENDATIONS.....	294
27	DATE AND SIGNATURE PAGE.....	295

LIST OF TABLES

Table 1.1 Mpama North Mineral Resource Estimate at 0.5%Sn Cut Off Grade, 9 May 2016	16
Table 1.2 Bisie Mpama North Measured and Indicated Mineral Resources grade tonnage table, 9 May 2016.....	17
Table 1.3 Bisie Mpama North Zone Inferred Mineral Resources grade tonnage table, 9 May 2016.....	17
Table 1.4 Mpama North Mineral Reserve estimate at 1.4% Sn cut-off grade	18
Table 1.5 Bisie capital cost estimate	23
Table 1.6 Mpama North operating cost estimate	24
Table 1.7 Net present value at various tin prices	25
Table 2.1 Qualified Person responsibility	27
Table 4.1 List of PE13155 beacon coordinates	31
Table 4.2 Alphamin exploration and exploitation permit details.....	32
Table 5.1 Climate data for Walikale	39
Table 9.1 Survey parameters for the airborne geophysical survey	55
Table 9.2 Lithological units and exploration targets delineated by interpretation of geophysical data .	55
Table 11.1 Frequency of QAQC samples used	68
Table 11.2 Tin grade for CRMs used at Bisie and number analysed.....	70
Table 11.3 Certified values of CRMs used at Bisie	70
Table 11.4 Summary of CRM analyses.....	72
Table 11.5 Mean values and standard deviation of original versus field duplicates at Bisie	73
Table 11.6 Mean values and standard deviation of original versus pulp duplicates at Bisie.....	75
Table 11.7 Mean values and standard deviation of ALS versus 2013 SGS pulp duplicates at Bisie	75
Table 11.8 Mean values and standard deviation in ppm of ALS versus 2015 SGS pulp duplicate assays at Bisie.....	78
Table 11.9 Mean values and standard deviation in ppm of ALS versus 2016 SGS pulp duplicate assays at Bisie.....	82
Table 11.10 Results of the BGS-CRM No355 assays for the 2016 confirmation assay program.....	82
Table 12.1 Check sample assay results.....	87
Table 12.2 Check sample assay results – re-assays	88
Table 12.3 Drillhole cores for which mineralization was visually verified	89
Table 14.1 Summary of the raw validated sample data at Mpama North.....	96
Table 14.2 Default density value applied for each rock type in the waste zones at Bisie.	98
Table 14.3 Summary statistics (de-clustered) of the estimation 1 m composite data	103

Table 14.4 Summary Statistics (de-clustered) of the estimation 1 m composite data for tin accumulation	105
Table 14.5 Summary statistics (de-clustered) of the estimation 1 m composite data for Sn accumulations separated into high and low grade populations.....	107
Table 14.6 Impact of capping the estimation data	107
Table 14.7 Semi-variogram Parameters – Main Vein system, Mpama North	111
Table 14.8 Indicator semi-variogram – Main Vein System, Mpama North	112
Table 14.9 Above and below threshold semi-variogram parameters – Main Vein system, Mpama North.....	113
Table 14.10 Block model prototype parameters for Bisie, Mpama North.....	114
Table 14.11 Dynamic anisotropy search parameters for Bisie, Mpama North	115
Table 14.12 Validation of block model filling	115
Table 14.13 Search parameters for Mpama North – ordinary kriging.....	118
Table 14.14 Search parameters for Mpama North – indicator approach	119
Table 14.15 Comparison between drillhole and model data values.....	122
Table 14.16 Bisie Mpama North Mineral Resource at 0.50 % Sn cut-off grade, 09 May 2016	128
Table 14.17 Bisie Mpama North Mineral Resources by zone and category, at 0.50% Sn cut-off grade, 9 May 2016.....	129
Table 14.18 Bisie Mpama North Measured and Indicated Mineral Resources grade tonnage table, 09 May 2016.....	130
Table 14.19 Bisie Mpama North Zone Inferred Mineral Resources grade tonnage table, 09 May 2016.....	130
Table 14.20 Bisie Mpama North comparison between previous estimates and 09 May 2016 estimate at 0.50% Sn cut-off grade	131
Table 14.21 Checklist of reporting criteria	132
Table 15.1 Cut-off grade calculation	137
Table 15.2 Demonstration of project viability for declaring Mineral Reserves.....	138
Table 15.3 Mineral Reserves for Mpama North at 1.4%Sn cut-off grade.....	139
Table 16.1 Summary of rock mass quality data	144
Table 16.2 Summary of joint orientation data.....	144
Table 16.3 Summary of rock strength test results	145
Table 16.4 Summary of Hoek-Brown and Mohr-Coulomb Parameters	145
Table 16.5 Summary of intact rock strength	146
Table 16.6 Rock block, rock mass and design rock mass strength	147
Table 16.7 Underground support requirements.....	153

Table 16.8 Assessment of cavability using Laubscher (1990) guidelines	154
Table 16.9 Results of Laubscher (1990) MRMR rating.....	154
Table 16.10 Results of the Laubscher & Jakubec (2001) MRMR rating	155
Table 16.11 Blast design parameters for SLC.....	167
Table 16.12 Selected mining equipment	169
Table 16.13 Ventilation design parameters	170
Table 16.14 Air requirements based on active diesel powered fleet.....	171
Table 16.15 Fan and power requirements.....	173
Table 16.16 Mine scheduling parameters applied	174
Table 16.17 Life of mine schedule	175
Table 16.18 Mine service water usage	176
Table 16.19 Mine dewatering pumping requirements.....	176
Table 16.20 Compressed air requirements	177
Table 19.1: World Supply/Demand Balances in Refined Tin.....	198
Table 21.1 Project Capital Costs (cost in US\$ millions).....	227
Table 21.2 Control Budget Estimate	228
Table 21.3 Foreign currency schedule.....	228
Table 21.4 Mine operating costs.....	229
Table 21.5 Stopping costs	230
Table 21.6 Unit development costs for a 4.0mW x 4.5mH end	230
Table 21.7 Reagent consumption costs	231
Table 21.8 Grinding media costs.....	231
Table 21.9 Other plant consumables.....	231
Table 21.10 Maintenance cost forecast.....	232
Table 21.11 Power generation costs.....	233
Table 21.12 Salaries and wages operating cost	235
Table 21.13 Haulage costs.....	236
Table 21.14 Shipping Costs.....	236
Table 21.15 Export taxes and fees	237
Table 21.16 Clearing agent fees.....	237
Table 21.17 Operating Cost Estimate.....	239
Table 22.1 Annual revenue and cost statistics.....	242
Table 22.2 Project Peak Funding Requirements (Nominal Terms)	243
Table 22.3 Operating Cost Estimate.....	244

Table 22.4 Net Present Value Summary.....	245
Table 24.1 Access Route Road Freight Distances.....	256
Table 24.2 Residue Disposal Facility Design Criteria.....	259
Table 24.3 Residue Disposal Facility Seep Input Parameters.....	265
Table 24.4 Factor of Safety Requirements – Side Slopes	266
Table 24.5 Closure Liability Calculation.....	277
Table 24.6 Proposed Staffing Levels.....	281
Table 24.7: Risk Matrix.....	283
Table 24.8: Bisie Business Risk Register.....	287

LIST OF FIGURES

Figure 1.1 Location Map.....	14
Figure 1.2 Bisie process flow sheet	19
Figure 1.3 Bisie site – 3D block plan	21
Figure 1.4: Project NPV sensitivity	25
Figure 4.1: Alphamin Bisie Mining SA corporate structure.....	30
Figure 4.2 Location map showing Alphamin exploration and exploitation permits (Mpama North located on PE13155)	31
Figure 5.1 Intersection of Bisie access road with Walikale to Bukavu national road (N3)	36
Figure 5.2 Bisie access road	37
Figure 5.3 Bridge over Biruwe River on Bisie access road	38
Figure 5.4 Steep topography and dense vegetation cover in the project area.....	39
Figure 7.1 Regional geology with Alphamin tenement locations.....	42
Figure 7.2 Landsat image showing the limits of the granite pluton adjacent to Bisie Ridge	43
Figure 7.3 Bisie stratigraphic column	45
Figure 7.4 Shear zone structure (blue) occurring in the Hangingwall of the Mpama North deposit south of 9885870N (red) looking west. Hangingwall vein zone shown in pink	46
Figure 7.5 Shear zone structure (blue) occurring in the Footwall of the Mpama North deposit (red) north of 9885870N looking east	47
Figure 7.6 Structure and geology cross section interpretation of the Wedge area at section 9885615N.....	48
Figure 7.7 Photograph of core showing the botryoidal texture of the pink cassiterite and copper sulphides (in fractures).....	49
Figure 7.8 Photograph of core showing massive sphalerite (zinc) and galena (lead)	50
Figure 9.1 Soils sampling campaign at Mabeka on PR 10346, showing results of Pb Niton analysis.....	56
Figure 9.2 Copper and tin in soil anomaly on Bisie Ridge	57
Figure 9.3 Comparison between laboratory and Niton soil analyses.....	58
Figure 10.1 Mpama South drill collars, with significant intersects	61
Figure 10.2 Schematic section 9884650N showing drillholes BGH001, BGC006, and BGH007 and 007A at Mpama South prospect.....	62
Figure 10.3 Schematic section 9886000N showing drillholes at Mpama North prospect	63
Figure 10.4 Mpama North schematic drill hole locality map showing significant intercepts and drillhole collars and traces for Phase 1 and Phase 2 drilling	64

Figure 10.5 Mpama North schematic drill hole locality map showing significant intercepts for Phase 3 drilling..... 65

Figure 11.1 Blank sample results for tin (Sn), silver (Ag), copper (Cu), zinc (Zn) and lead (Pb)..... 69

Figure 11.2 CRM sample results for tin 71

Figure 11.3 Pulp duplicate results..... 74

Figure 11.4 Scatterplot for ALS versus SGS 2013 tin pulp duplicate assays 76

Figure 11.5 Control chart for CRMs assayed by SGS in 2013 77

Figure 11.6 Scatterplot for ALS versus SGS 2015 assays of 2014 samples - tin pulp duplicate assays ... 78

Figure 11.7 Control chart for CRMs assayed by SGS in May 2015 79

Figure 11.8 Scatterplot for ALS versus Set Point 2015 assays of 2014 samples - tin pulp duplicate assays..... 80

Figure 11.9 Control chart for CRMs assayed by Set Point in June 2015 81

Figure 11.10 Scatterplot for ALS versus SGS 2016 assays of 2015 samples - tin pulp duplicate assays. Upper graph shows SGS tin assay by XRF and lower graph by titration 83

Figure 11.11 Control charts for CRMs assayed by ALS in 2016 for the re-assay program 84

Figure 11.12 Scatterplot for ALS 2016 re-assays versus ALS pre 2015 assays..... 85

Figure 12.1 Scattergrams of tin and copper check sample assay results 88

Figure 13.1 MINTEK Pilot Scale Shaking Table 92

Figure 13.2 MINTEK bench scale flotation cell 92

Figure 14.1 Histogram and cumulative frequency plot of the sample length data..... 95

Figure 14.2 Log cumulative frequency plot of the sample Sn grade data 97

Figure 14.3 Regression Analysis for SG versus Sn grade..... 98

Figure 14.4 QQ plot of gas pycnometer SG versus wet-dry method 99

Figure 14.5 Isometric View of the DTM created from the LIDAR survey data - view is approximately to the north..... 100

Figure 14.6 Isometric views of the April 2016 model, view to east (top) and west (bottom) 102

Figure 14.7 Histograms and log probability Plots for Sn accumulation..... 106

Figure 14.8 Semi-variograms for Tin Grade (Main Vein) 110

Figure 14.9 Indicator semi-variograms for 80Sn%/m (Main Vein)..... 112

Figure 14.10 Threshold semi-variograms for Main Vein Zone <80Sn%/m..... 113

Figure 14.11 Threshold semi-variograms for Main Vein Zone >80Sn%/m..... 114

Figure 14.12 Illustration of the search distance derived from the linear portion of the indicator semi-variogram model..... 116

Figure 14.13 Sections through block model and drillhole data illustrating correlation between model and data (note sections are 255 m apart)..... 120

Figure 14.14 Sectional validation plots for Sn% (model grades back calculated from the accumulations).....121

Figure 14.15 Sectional validation plots for Sn% - Indicator versus ordinary kriged estimate.....123

Figure 14.16 Mineral Resource classification, Main Vein - long section looking eas.....126

Figure 14.17 Mineral Resource classification, Hangingwall Vein (Top) and Footwall Vein (Bottom) - long sections looking east127

Figure 16.1: Rock Mass Rating for all rock types143

Figure 16.2: Q-Index for all rock types.....143

Figure 16.3: Africa Region k-Ratios146

Figure 16.4: Boxcut slope profile.....147

Figure 16.5: Boxcut profile with spiling bar support148

Figure 16.6: Trucking Decline Portal – Cross Section.....150

Figure 16.7: Trucking Decline Portal – Cross Section First 50m.....151

Figure 16.8: Trucking Decline Portal – Cross Section-Beyond 50m152

Figure 16.9: Strike distance at which caving will initiate.....156

Figure 16.10: Stable and failure stability charts for chlorite and mica schists157

Figure 16.11: Stable and failure stability charts for amphibolite schists158

Figure 16.12: Estimated shear failure of joints at Bisie.....159

Figure 16.13: Schematic long section – SLC162

Figure 16.14: Typical level plan – SLC.....162

Figure 16.15: Isometric view of mine access164

Figure 16.16 Development required over the life of mine165

Figure 16.17 Typical slot raise position relative to stoping direction.....166

Figure 16.18 Typical section through SLC slot x/cut with slot raise and blast hole rings167

Figure 16.19 Stope design and grades looking north-west.....168

Figure 16.20: Schematic diagram of the mine ventilation layout172

Figure 16.21: General arrangement of main fan173

Figure 16.22 Development profile over the life of mine174

Figure 16.23: Ore production profile175

Figure 16.24: Dirty water handling schematic.....177

Figure 17.1: Process plant flow sheet.....180

Figure 18.1 3D site layout view.....187

Figure 18.2 Mining Infrastructure188

Figure 19.1: Tin Use by Sector.....194

Figure 19.2: Mine Production Trends197

Figure 19.3: Forecast Production/Consumption Estimates to 2020..... 198

Figure 19.4: Cumulative Cost Curve for Worldwide Tin Production199

Figure 20.1: Sensitivity analysis of the study area vegetation.....201

Figure 20.2: Project-Affected Communities (PACs) in the Study Area.....203

Figure 21.1 Mining Capital Footprint224

Figure 21.2 Process plant design225

Figure 22.2: Project NPV sensitivity.....245

Figure 24.1 Project Execution Schedule248

Figure 24.2: Rebel groups active in the greater Walikale area.....250

Figure 24.3 Project Access Route Options256

Figure 24.4: Typical rough terrain vehicle used for final leg transport.....257

Figure 24.5: Particle size distribution curve of expected tailings products.....260

Figure 24.6: Site Selection TSF options.....262

Figure 24.7: Position of critical sections through the TSF and DWD264

Figure 24.8: Physical configuration of the TSF seepage model through Section A-A.....265

Figure 24.9: Definition of freeboard268

Figure 24.10: Catchment Area of TSF269

Figure 24.11 Mining Shift Roster Arrangements280

LIST OF APPENDICES

Appendix 1 : Glossary of Technical Terms

1 SUMMARY

1.1 PROPERTY DESCRIPTION & OWNERSHIP

Alphamin, through its jointly owned subsidiary, Alphamin Bisie Mining SA (ABM), has legal title over five exploration permits (No's: PR 5270; PR 10346; PR 5266; PR 5267; and PR 4246) and one mining permit (PE 13155) in total covering approximately 1,270 km² in the North Kivu Province of the Democratic Republic of the Congo.

The Project is located approximately 180 km northwest of Goma, the capital of North Kivu and approximately 60 km northwest of Walikale centre.

Figure 1.1 Location Map

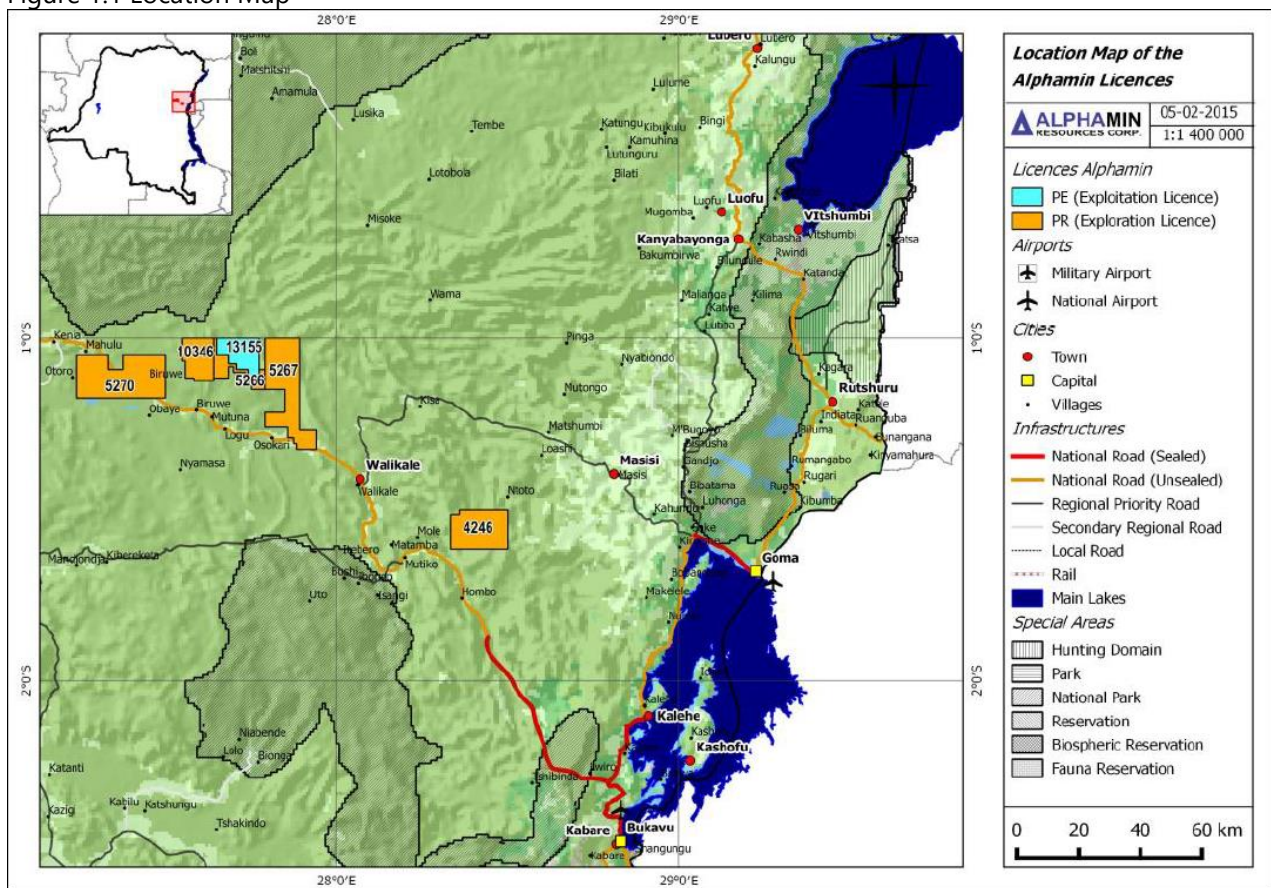

Source: Alphamin

1.2 GEOLOGY AND MINERAL RESOURCES

The mineralization at Bisie is associated with a steeply dipping (approximately 65° east) north to south striking zone of intense chloritisation contained within micaceous schists. The main tin bearing chloritised zone is on average approximately 9 m thick. Narrower subordinate zones occur several metres above and below the main zone in certain areas. The mineralization occurs in the form of irregular high grade veins of botryoidal cassiterite several tens of centimetres thick and lesser amounts of cassiterite blebs and vein fragments irregularly disseminated in the chlorite schist. The mineralized zone plunges approximately 35° to the north, although local steeper plunging high grade trends are

evident. Copper, lead and zinc occur as chalcopyrite, galena and sphalerite in locally significant concentrations, together with silver. Two zones of mineralization have to date been discovered at Bisie; these are known as Mpama North, which is the zone for which this Mineral Resource estimate applies, and Mpama South, which occurs approximately 0.75 km to the south.

Mr J.C. Witley (the Qualified Person (QP) for this Mineral Resource estimate) of MSA, an independent consulting company, visited the Bisie project site from 18 to 20 July 2013, from 20 to 22 May 2014 and from 11 to 13 August 2015. During the first site visit he conducted independent check sampling, and in this and subsequent visits carried out inspection of the drillhole cores and drilling sites. The check sample assays confirmed the original sample assays are within reasonable limits for this style of mineralization. The results of drilling at Mpama North obtained since the last site visit are consistent with mineralization observed by the QP during the most recent and prior site visits.

The assay results received from the primary laboratory (ALS Chemex South Africa (ALS)) have been confirmed by a quality assurance and quality control programme including duplicate assays completed by a second and third laboratory.

The QP considers that the exploration work conducted by Alphamin was carried out using appropriate techniques for the style of mineralization at Bisie, and that the resulting database is suitable for Mineral Resource estimation.

The Mineral Resource estimate was based on tin, copper, lead, zinc and silver assays and density measurements obtained from the cores of 122 NQ size diamond drillholes, which were completed by Alphamin between July 2012 and November 2015 inclusive. In addition to the exploration drillholes, the split cores from 21 PQ size holes were used in the estimate. These holes were drilled in three clusters for the purpose of obtaining a metallurgical test sample.

Mineral Resource estimation was carried out using Datamine Studio 3 software. A 0.35 % Sn threshold was used to define the mineralized envelopes. Wireframes were constructed for the mineralized zones and a block model was constructed by filling the wireframe solids with parent cells of 20 m in the approximate strike direction, 10 m in the dip direction and 2 m across the zone. Rotated block models were constructed in order to best fit the mineralized envelopes that dip steeply to the east.

Semi-variograms were created for each of the estimated attributes and each attribute was estimated into the block models using ordinary kriging. Two statistical populations of tin grade were defined, the high grade population being estimated separately from the lower grade and the estimates then combined. Search distances and orientations were aligned with the respective variogram range for each attribute estimated. For tin, accumulations of density and grade were used to appropriately reflect the relationship between tin grade and density and the tin grades were then back-calculated from the accumulation estimate. Outlier control was performed on the 1 m composite data and included a restricted search distance for the high grade tin population.

The Mineral Resource estimate is limited to deeper than 50 m below surface in the areas where artisanal mining has taken place. The shallow area of Mpama North has been partially depleted by mining and the quantity of remaining Mineral Resource in the affected area cannot be stated within reasonable limits. The maximum depth of the Mineral Resource is dictated by the location of the diamond drilling data. The Mineral Resource extends for approximately 700 m in the northerly plunge direction and the deepest Mineral Resource reported is approximately 550 m below surface, the mineralization being open down-plunge. Estimates were extrapolated for a maximum distance of 20 m up- or down-plunge

from the nearest drillhole intersection. Extrapolation is minimal over most of the Mineral Resource as the up-and down dip limits have been well defined by the drilling.

The Mineral Resource estimate has been completed by Mr J.C. Witley (BSc Hons, MSc (Eng.)) who is a geologist with 28 years' experience in base and precious metals exploration and mining as well as Mineral Resource evaluation and reporting. He is a Principal Resource Consultant for The MSA Group (an independent consulting company), is a member in good standing with the South African Council for Natural Scientific Professions (SACNASP) and is a Fellow of the Geological Society of South Africa (GSSA). Mr Witley has the appropriate relevant qualifications and experience to be considered a "Qualified Person" for the style and type of mineralization and activity being undertaken as defined in National Instrument 43-101 *Standards of Disclosure of Mineral Projects* (NI 43-101).

The Mineral Resource was estimated using The Canadian Institute of Mining, Metallurgy and Petroleum (CIM) Best Practice Guidelines (2003) and is reported in accordance with the 2014 CIM Definition Standards, which have been incorporated by reference into National Instrument 43-101 – *Standards of Disclosure for Mineral Projects* (NI 43-101). The Mineral Resource is classified into the Measured, Indicated and Inferred categories as shown in Table 1.1.

The Mineral Resource is reported at a base case tin grade of 0.50 %, which the QP considers will satisfy reasonable prospects for economic extraction given the high in-situ value of the mineralization. All Mineral Resources are reported inclusive of Mineral Reserves.

Table 1.1 Mpama North Mineral Resource Estimate at 0.5%Sn Cut Off Grade, 9 May 2016

Category	Tonnes (Millions)	Sn %	Sn tonnes (thousands)	Cu %	Zn %	Pb ppm	Ag g/t
Measured	0.46	4.31	19.6	0.22	0.12	0.007	1.4
Indicated	4.14	4.55	188.4	0.32	0.16	0.010	2.8
Total M&I	4.60	4.52	208.1	0.31	0.15	0.010	2.7
Inferred	0.54	4.25	22.8	0.16	0.09	0.013	1.4

Notes:

*All tabulated data has been rounded and as a result minor computational errors may occur
 Mineral Resources which are not Mineral Reserves have no demonstrated economic viability.*

The Mineral Resource is reported inclusive of Mineral Reserves.

Alphamin has an 80.25 per cent interest in the Bisie Project. The Gross Mineral Resource for the Project is reported.

The Mineral Resource is tabulated using a number of cut-off grades as shown in Table 1.2 for the Measured and Indicated Mineral Resource and in Table 1.3 for the Inferred Mineral Resource.

Table 1.2 Bisie Mpama North Measured and Indicated Mineral Resources grade tonnage table, 9 May 2016

Cut-Off Sn %	Tonnes (Millions)	Sn %	Sn tonnes (thousands)	Cu %	Zn %	Pb ppm	Ag g/t
0.25	4.66	4.47	208.3	0.31	0.15	0.010	2.6
0.50	4.60	4.52	208.1	0.31	0.15	0.010	2.7
0.75	4.44	4.66	207.1	0.32	0.16	0.010	2.7
1.00	4.23	4.85	205.2	0.32	0.16	0.010	2.7
1.50	3.67	5.40	198.2	0.33	0.16	0.010	2.8
1.80	3.32	5.79	192.5	0.34	0.17	0.010	2.9
2.00	3.07	6.11	187.7	0.34	0.17	0.010	2.9

Notes:

All tabulated data has been rounded and as a result minor computational errors may occur Mineral Resources which are not Mineral Reserves have no demonstrated economic viability.

The Mineral Resource is reported inclusive of Mineral Reserves.

Alphamin has an 80.25 per cent interest in the Bisie Project. The Gross Mineral Resource for the Project is reported.

Table 1.3 Bisie Mpama North Zone Inferred Mineral Resources grade tonnage table, 9 May 2016

Cut-Off Sn %	Tonnes (Millions)	Sn %	Sn tonnes (thousands)	Cu %	Zn %	Pb ppm	Ag g/t
0.25	0.55	4.17	22.9	0.16	0.09	0.012	1.4
0.50	0.54	4.25	22.8	0.16	0.09	0.013	1.4
0.75	0.51	4.40	22.7	0.17	0.09	0.013	1.5
1.00	0.48	4.63	22.4	0.17	0.10	0.013	1.5
1.50	0.38	5.58	21.1	0.19	0.10	0.014	1.6
1.80	0.35	5.94	20.6	0.19	0.11	0.015	1.6
2.00	0.33	6.21	20.2	0.19	0.11	0.014	1.6

Notes:

All tabulated data has been rounded and as a result minor computational errors may occur Mineral Resources which are not Mineral Reserves have no demonstrated economic viability.

The Mineral Resource is reported inclusive of Mineral Reserves.

Alphamin has an 80.25 per cent interest in the Bisie Project. The Gross Mineral Resource for the Project is reported.

1.3 MINERAL RESERVE ESTIMATE

The planned mining method is sub-level caving and the following modifying factors were applied to convert the Mineral Resource estimate to a Mineral Reserve as follows:

- Cut-off grade – 1.4% Sn.
- Ore Recovery – 85%.

- Planned Dilution – 14.5%.
- Unplanned Dilution – 35%.

Table 1.4 Mpama North Mineral Reserve estimate at 1.4% Sn cut-off grade

Classification	Tonnes (millions)	Tin (%)	Tin tonnes (thousands)
Proven	0.38	4.17	15.9
Probable	4.29	3.53	151.4
Total Proven and Probable	4.67	3.58	167.3

No inferred Mineral Resources have been included in the estimation of Mineral Reserves.

1.4 MINERAL PROCESSING AND METALLURGICAL TEST WORK

The Bisie tin plant is designed to treat a maximum of 390 000 t/a of ore and produce 15 500 t/a of tin concentrate. The plant comprises the following processes:

- Crushing of run of mine;
- Screening of the crushed ore;
- Pre-concentration of plant feed material from 3.5%Sn material to 40%Sn material by jigs;
- Jig concentrate is screened. -8mm to +1mm material feeds the high grade circuit. -1mm material feeds the low grade circuit. Jig tailings discarded to tailings storage facility;
- High grade concentrate is milled and subjected to gravity concentration using a combination of spirals and shaking tables. Concentrate sent to reverse flotation for sulphide removal, tailings sent to low grade circuit;
- Low grade concentrate is milled and processed in low grade circuit using spirals and shaking tables. Concentrate sent to reverse flotation for sulphide removal, tails sent to tailings disposal circuit
- The low grade circuit tails are thickened and discarded to tailings storage facility
- The high grade and low grade concentrates are combined and treated through a magnetic separator to remove iron, then filtered and bagged for sale.

Figure 1.2 Bisie process flow sheet

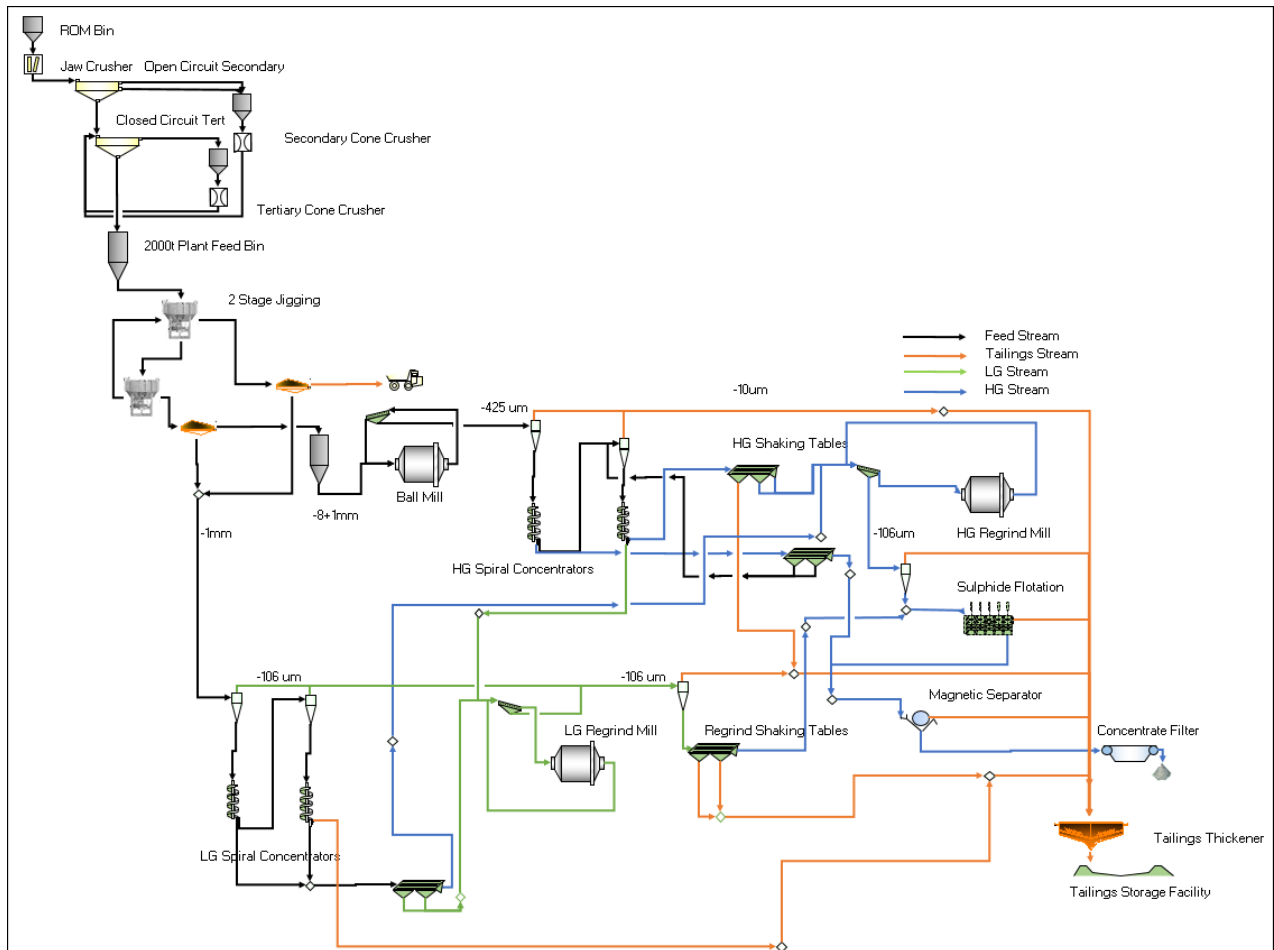

Source DRA

Metallurgical test work conducted at Mintek has confirmed plant recoveries of 73%Sn and concentrate grades above 61%Sn should be achieved.

1.5 ENVIRONMENTAL STUDIES, PERMITTING AND SOCIAL COMMUNITY IMPACT

ABM has obtained the necessary Environmental permits in order to start construction activities at the Project site. The social program of information and workshops that have been running for over two years will continue through the duration of operations. ABM has a number of sustainable programs planned that will positively develop the social environment. This will be achieved by the existing commitment to maximize the recruitment of local personnel during both construction and operations. It is estimated that at least 450 people will benefit from direct employment and at least another 5000 will benefit indirectly. Local suppliers of goods and support services to the mine will be able to develop their businesses through increased opportunities. Education and training programs will raise the skills level of the workers in the area.

The remote location of the project in relation to the local communities and population assists in minimizing any potential impacts of the Project on the community and there is limited effect on land or property tenure. There are no impacts related to displacement of the local population.

1.6 SITE & INFRASTRUCTURE

The project site is accessible by road from Goma, the capital city of North Kivu Province. The main ports available to the project are Mombasa in Kenya and Dar es Salaam in Tanzania, with all transport from port to mine being by road.

The Project site was established as an exploration camp in 2011. The facilities have expanded over time and the project site is now equipped with a clinic, emergency response room, security control room, offices, ICT infrastructure, accommodation for 150 people, power generation, and messing facilities.

The proposed Project infrastructure will support the maintenance, mining, concentrator plant, tailings storage facilities and construction operations as follows:

- Services required for mining activities.
- Explosives storage facilities;
- Concentrator plant services and infrastructure.
- Water services and sewage treatment for process plant and administration buildings;
- Camp accommodation for up to 700 persons, messing, water treatment and sewage treatment facilities.
- Security arrangements around the mining, processing, administration and camp facilities;
- Voice and data communication facilities;
- Access roads and on-mine haul roads;
- Electrical power generation and distribution; and
- Tailings and waste rock storage facilities.

Figure 1.3 Bisie site – 3D block plan

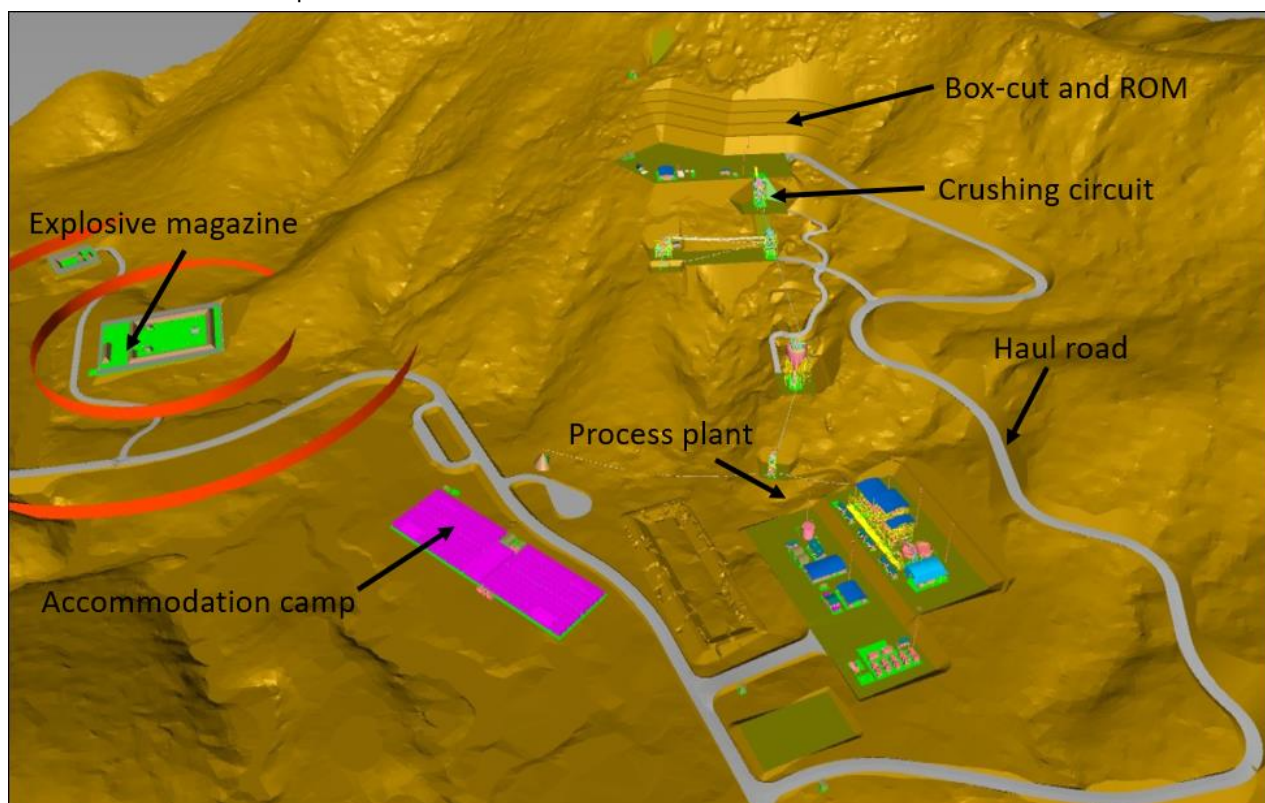

Source: DRA

1.7 CAPITAL COST ESTIMATE

The purpose of the capital cost estimate is to establish the project budget to sufficient accuracy to allow investment decisions. The estimate provides the pertinent cost data to establish the control budget for moving forward into project execution.

The capital cost estimate has an accuracy level of -10% to 10%, is stated in Q1 2017 terms, and was compiled on the following basis:

- Mining and process plant components were priced using quotations from reputable South African suppliers and vendors.
- Foreign currency elements of quoted prices were converted to United States Dollars, using the following key rates of exchange:
 - USD1 : ZAR14.29
 - USD1 : AUD1.30
 - USD1 : EUR0.90
- All applicable duties and taxes have been included in the capital cost estimate with the exception of Value Added Tax (which has however been included in the Project peak funding requirement)
- Risk analysis undertaken to establish the required level of design development;

- A combination of committed and firm bid prices for major mobile mining equipment were used for the estimate;
- Firm proposals were received for equipment packages;
- Material Take-Offs (MTOs) were developed from layouts, general arrangements and design calculations for site preparation, concrete, structural steelwork, mechanical bins and chutes, process piping and valves, electrical, and instrumentation. Pricing was developed based on actual quotes received and checked against recent experience with similar projects;
- Labour rates were based on similar mines within the Democratic Republic of Congo. Expatriate rates include all required in-country taxes;
- Committed unit labour rates for earthworks equipment operators were used for activities occurring before the arrival of the mining contractor;
- Labour productivity was calculated based on historical project experience and inclement weather factors were included within the execution program;
- Calculating the costs for freight, including 6x6 trucks to traverse the selected route within the DRC;
- Scheduling the work utilising the project execution plan;
- Detailed estimates of indirect costs. For this project, indirect items included:
 - Contractor general expenses;
 - EPCM costs;
 - Bulk diesel for mobile vehicles;
 - Power plant operation during construction phase;
 - Road construction and maintenance;
 - Freight costs including local taxes per truck and route survey costs;
 - Passenger air charters;
 - Owner's costs, including:
 - Owners project management team;
 - Owners pre-production site operations labour;
 - Owners General & Administration items;
 - General site indirect costs;
 - Accommodation camp catering and management;
 - Pre-operational readiness and commissioning services;
 - Operating, strategic and commissioning spares with commissioning assistance; and

- Contractor assistance during commissioning.

The table below outlines the estimated capital expenditure for the project with a base date of Q1 2017.

Table 1.5 Bisie capital cost estimate

Area	US\$ million
Mining	29.7
Plant	32.9
Infrastructure	28.5
Project indirect costs	22.3
Design development	8.0
Owners costs	30.0
Total Capital Costs	151.4

1.8 OPERATING COST ESTIMATE

The operating cost estimate was developed using:

- Contractor mining operation – firm bids received from several international mining contractors with DRC experience
- Owner team process plant operation –Alphamin to employ full complement of operating and maintenance staff. Reagent costs based on test work consumption rates and allow for transport to site;
- Site infrastructure – these costs relate to power generation and operation of the accommodation camps. Power generation costs based on \$1.5/litre diesel price;
- Sustaining capital costs – this is a calculated allowance made for repairs and replacement to mining fleet, electrical infrastructure, access road, tailings dam and process plant;
- Administration and general cost – allows for community development, security, environmental monitoring and general corporate costs;
- Logistics costs – freight of final product from mine to smelter;
- Treatment charges – includes smelting charges and penalties imposed for impurities in final concentrate;
- Export duties and fees – in accordance with DRC and North Kivu taxation regimes;
- DRC government royalty – in accordance with DRC Mining Code;
- Marketing commission – marketing costs from smelter to final user.

The target accuracy of the operating cost estimate is -10% to +10.

Table 1.6 Mpama North operating cost estimate

Activity	US\$/t Sn
Mining	2 909
Processing	384
Site infrastructure	1 394
Sustaining capital	297
Administration and general	1 253
Logistics	1 081
Treatment charges	1 555
Cash cost of tin produced	8 837
Export duties and fees	529
DRC Government royalty	416
Marketing commissions	577
Cash cost of tin sold	10 359

1.9 ECONOMIC ANALYSIS

- The analysis is based on an underground mining operation with a processing throughput of 360-390kt/a using Proven and Probable Mineral Reserves;
- Process plant recoveries of 73% of tin fed into the plant. Final concentrate grading 61%Sn;
- A forecast tin price of \$21,400/t;
- Construction of the underground mine commences in Q2 2017, plant commissioning in Q4 2018, production ramp-up in Q1 2019 with full nameplate capacity being achieved in H2 2019;
- Corporate taxes of 30%. A minimum tax of 1% of turnover applies to mining companies during the capital amortisation period;
- A 2% royalty on gross revenues less transport costs apply to the sale of tin in concentrate;

The results of the evaluation are presented below.

Table 1.7 Net present value at various tin prices

Discount Rate	Project NPV (US\$ millions)		
	US\$ 19,000/t	US\$ 20,000/t	US\$ 21,400/t
8	301.0	343.2	402.2
10	250.7	287.7	339.5
12	209.2	241.8	287.4
15	159.5	186.8	225.0

- The ungeared project IRR is 49.1%;
- Project payback period is 17-months from start of processing.
- The sensitivity chart below shows the NPV_{8%} variation due to changes in revenue, capital and operating costs, holding all other inputs constant.

Figure 1.4: Project NPV sensitivity

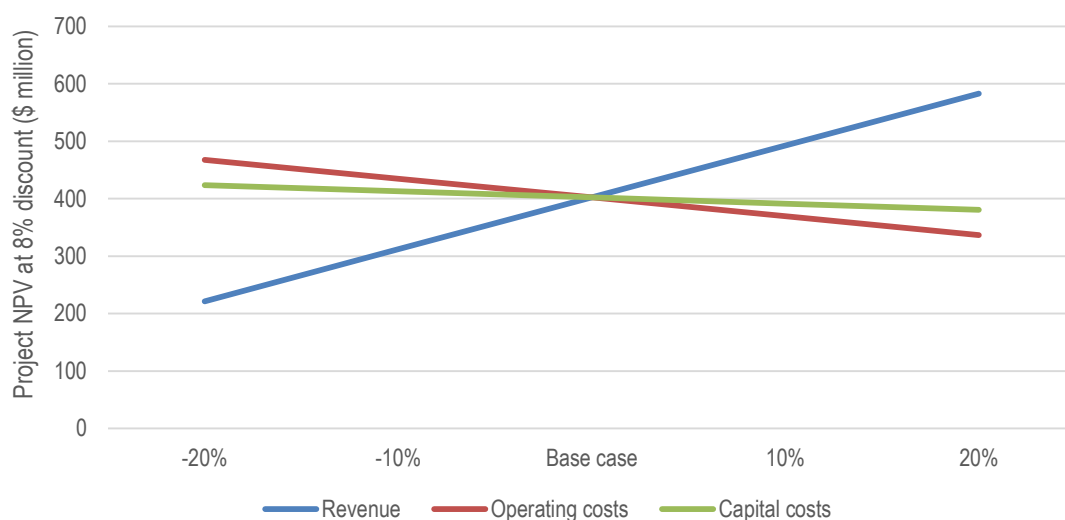

1.10 CONCLUSIONS

The Project is technically credible, utilising designs and practices that are proven in tin industry. Utilising a life of mine schedule based on Proven and Probable Mineral Reserves, the project is forecast to generate a positive NPV_{8%} for tin prices above \$12,500/t.

Over and above the economic benefits of the project, Mpama North has been designed to be environmentally sound and to provide socioeconomic benefits to the project affected communities.

1.11 RECOMMENDATIONS

The Bisie Front End Engineering Design Report indicates a robust project based on the assumptions made of tin recovery, execution schedule, and tin market conditions. It is recommended that the project be funded for development.

2 INTRODUCTION

2.1 SCOPE OF WORK

DRA was commissioned by Alphamin Resources Corp. (Alphamin, the Company) to undertake the Front End Engineering Design and prepare a Control Budget Estimate for project execution on the Company's Bisie Tin Project, located in the Walikale District, North Kivu Province, Democratic Republic of the Congo (DRC). Alphamin, through its jointly owned subsidiary (80.25% ownership, the remainder with the Industrial Development Corp. of South Africa and the government of the DRC), Alphamin Bisie Mining SA (ABM), has legal title over five exploration permits (No's: PR 5270; PR 10346; PR 5266; PR 5267; and PR 4246) and one mining permit (PE 13155) in total covering 1,270 km² in the North Kivu Province. Mpama North and Mpama South are located on PE 13155. Alphamin Bisie Mining SA was formerly known as Mining Processing Congo SPRL (MPC). Alphamin is a publicly traded company listed on the TSX Venture Exchange (TSX-V) under the symbol AFM and on the Frankfurt Stock Exchange under the symbol AORBSV.

The report has been prepared to comply with disclosure and reporting requirements set forth in National Instrument 43-101 *Standards of Disclosure for Mineral Projects* (NI 43-101), Companion Policy 43-101CP, Form 43-101F1, and the CIM Definition Standards for Mineral Resources and Mineral Reserves adopted by the CIM Council 10 May 2014.

All monetary figures expressed in this report are in United States of America dollars (US\$) unless otherwise stated. Coordinates shown on maps and sections are relative to UTM 35S and metres above mean sea level (amsl) unless otherwise stated.

2.2 PRINCIPAL SOURCES OF INFORMATION

This Report has been compiled by DRA, MSA and Alphamin. The areas of key responsibilities are as follows:

DRA

- Mine design and production scheduling
- Mineral Reserve estimation
- Processing plant design;
- Site infrastructure design;
- Tailings storage facility design;
- Project schedule, project execution plan and project capital cost development

MSA

- Geology and mineralization qualification;
- Mineral Resource estimation; and
- Drilling and sampling qualification.

Alphamin

- Environmental and social impact assessment and the management plans associated with these. Alphamin was assisted by EOH Coastal in compiling this section of the report;
- Market studies and offtake contracts;
- Security, administration, logistics, and general items;

Alphamin's mineral properties are considered to represent an advanced exploration project which is inherently speculative in nature. However, the QP's consider that the properties have been acquired on the basis of sound technical merit. The properties are also generally considered to be sufficiently prospective, subject to varying degrees of exploration risk, to warrant further exploration and assessment of their economic potential, consistent with the proposed programs.

The QPs have provided consent for the inclusion of the Technical Report for Alphamin's disclosure requirements and have not withdrawn that consent prior to lodgement.

2.3 QUALIFICATIONS, EXPERIENCE AND INDEPENDENCE

Three Qualified Persons (QPs), as defined by NI 43-101, were responsible for the preparation of this Technical Report. The Table below lists the qualifications for each QP, as well as the section(s) of the report for which they are responsible.

Table 2.1 Qualified Person responsibility

Qualified Person	Company	Report sections of responsibility
Jeremy Witley, BSc Hons, MSc (Eng.), Pr.Sci.Nat, FGSSA	The MSA Group	Sections 1.2, 2, 3, 7-12, 14
Mark Creswell, BSc (Eng), FSAIMM, MIMMM, Pr.Eng	DRA Projects	Sections 1, 2, 3, 13, 17, 18-22, 24, 25-27
John Anthony Cox BSc.Eng.(Mining) ARSM, Pr.Eng	Royal HaskoningDHV	Sections 15, 16, 21, 22, 25, 26

Mr Witley (BSc Hons, MSc (Eng.); Pr.Sci.Nat.) is a professional geologist with 28 years' experience in base and precious metals exploration and mining as well as Mineral Resource evaluation and reporting. He is a Principal Resource Consultant for MSA (an independent consulting company), is a member in good standing with the South African Council for Natural Scientific Professions (SACNASP) and is a Fellow of the Geological Society of South Africa (GSSA). Mr Witley has the appropriate relevant qualifications, experience, competence and independence to act as a "Qualified Person" as that term is defined in National Instrument 43-101 (*Standards of Disclosure for Mineral Projects*).

Mr Mark Creswell is a Fellow of the South African Institute of Mining and Metallurgy (FSAIMM). Mr Creswell has the appropriate relevant qualifications, experience, competence and independence to act

as a "Qualified Person" as that term is defined in National Instrument 43-101 (*Standards of Disclosure for Mineral Projects*).

Mr J A Cox BSc.Eng.(Mining) is a Fellow of the South African Institute of Mining and Metallurgy (FSAIMM) and a Professional Engineer of the Engineering Council of South Africa (ECSA) . Mr Cox has the appropriate relevant qualifications, experience, competence and independence to act as a "Qualified Person" as that term is defined in National Instrument 43-101 (*Standards of Disclosure for Mineral Projects*).

No authors of this report have or has had previously, any material interest in Alphamin or the mineral properties in which Alphamin has an interest. The relationship with Alphamin is solely one of professional association between client and independent consultant. This report is prepared in return for professional fees based upon agreed commercial rates and the payment of these fees is in no way contingent on the results of this report.

2.4 CURRENCY

Costs in this report are provided in United States dollars (USD or US\$), unless otherwise specified.

3 RELIANCE ON OTHER EXPERTS

Alphamin, through its wholly owned subsidiary, Alphamin Bisie Mining SA (ABM), has legal title (80 % ownership) over five exploration permits (No's: PR 5270; PR 10346; PR 5266; PR 5267; and PR 4246) and one mining permit (PE 13155) covering an aggregate area of approximately 1,270 km². The Bisie Project is located on PE 13155. Three of the licences are still under Force Majeure (PR 5270, PR 5267 and PR 4246).

The Consultants have not independently verified, nor are they qualified to verify, the legal status of these concessions. The present status of the concession listed in this report is based on information and copies of documents provided by Alphamin, and the report has been prepared on the assumption that the tenements will prove lawfully accessible for evaluation.

4 PROPERTY DESCRIPTION AND LOCATION

4.1 LOCATION

The Bisie Tin project is located in the Walikale District of the North Kivu Province of the DRC. It is located approximately 180 km northwest of Goma, the capital of North Kivu and approximately 60 km northwest of Walikale (Figure 4.2 below).

4.2 OWNERSHIP STRUCTURE

ABM is owned 80% by Alphamin, a TSX-V listed company, 15% by the Industrial Development Corp., and 5% by the GDRC. The simplified corporate structure is shown below.

Figure 4.1: Alphamin Bisie Mining SA corporate structure

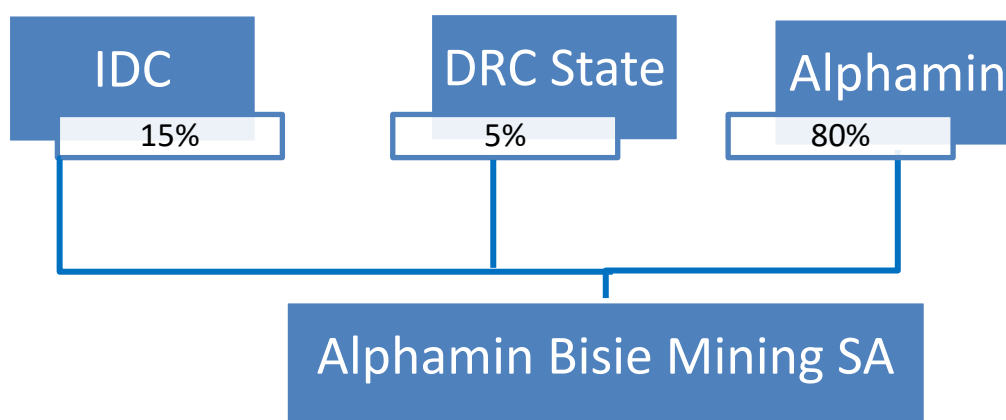

Source: Alphamin

4.3 MINERAL TENURE, PERMITTING, RIGHTS AND AGREEMENTS

Alphamin, through its wholly owned subsidiary, Alphamin Bisie Mining SA (ABM), has legal title over five exploration permits (*Permis de Recherches*) (No's: PR 5270; PR 10346; PR 5266; PR 5267; and PR 4246) and one exploitation permit (*Permis d'Exploitation*), PE 13155, covering the Bisie Project. They cover an aggregate area of approximately 1,270 km².

Figure 4.2 Location map showing Alphamin exploration and exploitation permits (Mpama North located on PE13155)

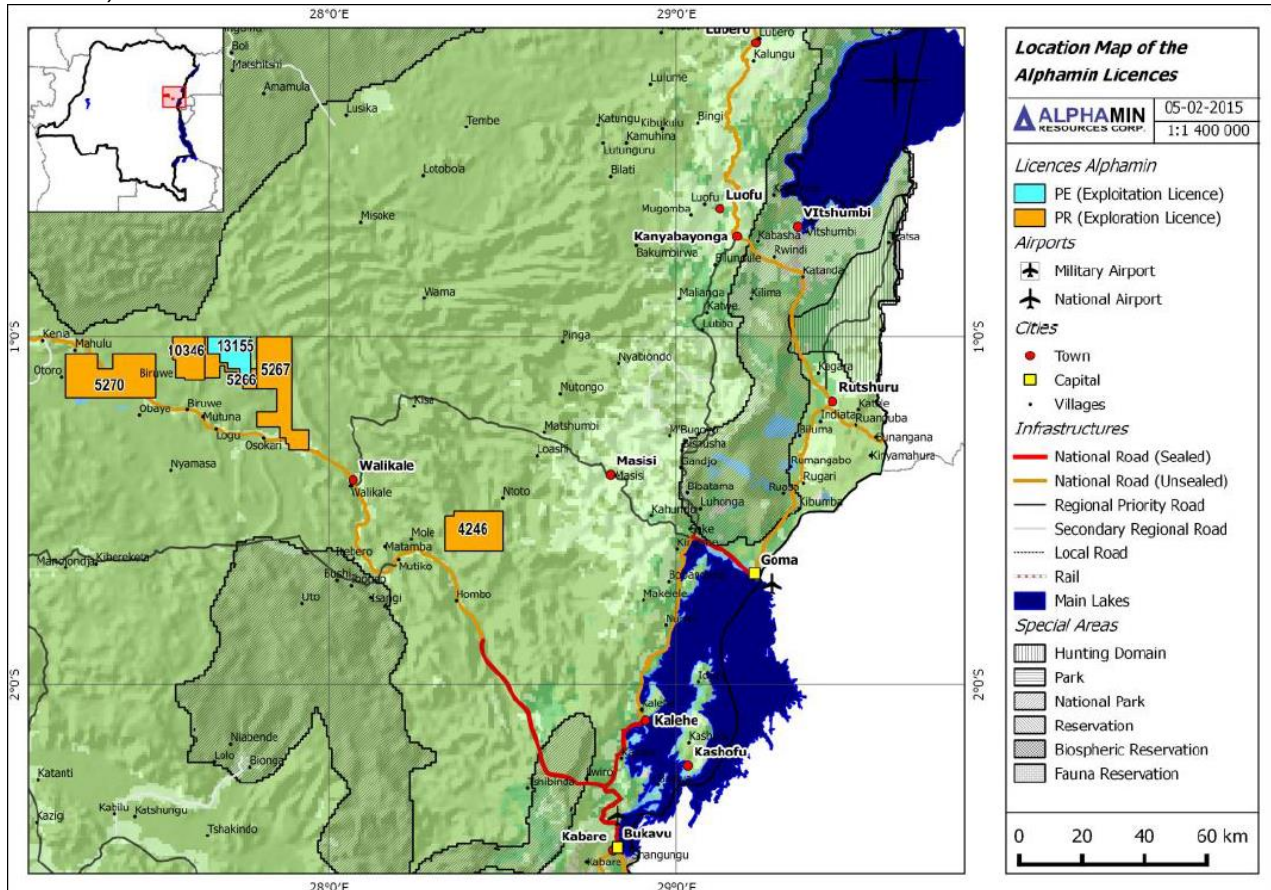

Sources: Licence coordinates: CAMI; Congo shape files: ESRI, DIVA-GIS

Note: Coordinates are referenced to WGS84

This Report primarily outlines the studies carried out on the PE 13155 exploitation permit. The geographical coordinates of PE 13155 are tabled below.

Table 4.1 List of PE13155 beacon coordinates

Beacon Number	Longitude	Latitude
1	27°39'00"E	01°03'00"S
2	27°39'00"E	01°00'00"S
3	27°46'30"E	01°00'00"S
4	27°46'30"E	01°07'00"S
5	27°44'30"E	01°07'00"S
6	27°44'30"E	01°05'30"S
7	27°42'30"E	01°05'30"S
8	27°42'30"E	01°04'30"S
9	27°41'00"E	01°04'30"S
10	27°41'00"E	01°03'00"S

Boundary beacons were emplaced by representatives from CAMI on PE 13155 in accordance with Mining Regulations.

Details of all of the exploration permits owned by Alphamin are tabled below.

Table 4.2 Alphamin exploration and exploitation permit details

No	Approximate Area (km ²)	Commodities	Certificate Number	Validity Period
PR5266	85 Blocks (±72.60 km ²)	Tin, gold, copper, zinc, lead and silver	CAMI/CR/2935/2006	Renewed on 24 November 2014, valid until 23 November 2019
PE13155	151 Blocks (±128.96 km ²)	Tin and gold	CAMI/6923/15	Granted on 3 February 2015, valid until 3 February 2045
PR4246	274 Blocks (±232.78 km ²)	Gold, tin, copper, platinum, cobalt, silver, niobium, tantalum, and wolframite	CAMI/CR/2970/2006	21 September 2006 to 23 May 2023
PR 5267	380 Blocks (±322.83 km ²)	Tin and gold	CAMI/CR/2936/2006	29 September 2006 to 23 May 2023
PR 5270	440 Blocks (±373.81 km ²)	Tin and gold	CAMI/CR/2939/2006	29 September 2006 to 23 May 2023
PR10346	155 Blocks (± 132.38 km ²)	Coltan and gold Application for additional elements (Sn, Cu, Zn, Pb and Ag) submitted and in process	CAMI/CR/6635/12	02 July 2009 to 01 July 2014. Renewed and valid until 2019

Although the exploitation permit for PE 13155 does not currently include silver, copper, lead and zinc, ABM's applications for these additional elements was accepted under Article 59 of the Mining Code and Articles 111-114 of the Mining Regulations, and the file is properly recorded with CAMI (*DRC Cadastre Minier*).

4.3.1 Force Majeure

Pearl (2011) noted that, due to events beyond MPC's control which prevented it from fulfilling its obligations and exercising and enjoying its mineral rights, notice of *Force Majeure* was given to the Mining Registry on 19 March 2009 in relation to all MPC Properties at the time (PR 5266, PR 4246, PR 5267, and PR 5270). The declaration of *Force Majeure* for these exploration permits was accepted on 26 March 2009.

The *Force Majeure* was caused by the presence of uncontrolled armed groups and other outlaws who forced the MPC employees to leave the Bisie site and also caused damage to the exploration camp and equipment. The unsafe climate at the time contributed to the recognition of a generalised *Force Majeure* for the mining operators based in the eastern part of the DRC.

PR 10346 is a more recent acquisition and was not affected by the *Force Majeure*.

According to the Mining Code Article 297, the requirements to perform the titleholders' obligations are suspended from the date of the occurrence of the Force Majeure. The term of the concession will be extended for a period equivalent to the duration of the Force Majeure. When the *Force Majeure* ceases, the titleholder is required to inform the Mining Registry within ten days, and to resume performance of its obligations (Pearl, 2011).

Force Majeure was lifted on PR 5266 on 20 January 2012 and MPC was allowed to resume work on the concession. The licence was renewed on the 24 November 2014 and its validity extended until 23 November 2019.

Force Majeure was lifted on PR 4246, PR 5267, and PR 5270 on 24 May 2016 and ABM is allowed to resume work on the concessions.

4.4 MINING LEGISLATION IN THE DRC

4.4.1 Mineral Property and Title

The following review of mineral legislation in the DRC is summarised from Hubert André-Dumont (2013) and the Mining Code.

The principal legislation governing mining activities in the DRC is the Mining Code (Law No. 007/2002 dated 11 July 2002). The applications of the Mining Code are provided by the Mining Regulations enacted by Decree No. 038/2003 of 26 March 2003 (the 2003 Mining Regulations). The legislation incorporates environmental requirements.

All mineral rights in the DRC are held by the State, and the holder of mining rights gains ownership of the mineral products for sale. Under the 2002 Mining Code, mining rights are regulated by Exploration Permits (*Permis de Recherches Minières* or PRs), Exploitation Permits (*Permis d'Exploitation* or PEs) small-scale Exploitation Permits and tailings Exploitation Permits (*Certificats d'Exploitation des Rejets* or PERs).

Under the 2003 Mining Regulations, the DRC is divided into mining cadastral grids using a WGS84 geographic coordinate system. The grid defines uniform quadrangles or cadastral squares (*carrés*), each 84.955 ha in area. The perimeter of a mining right is in the form of a polygon consisting of entire contiguous quadrangles subject to the limits relating to the borders of the DRC and those relating to reserved prohibited and protected areas as set forth on the 2003 Mining Regulations. Perimeters are exclusive and may not overlap.

4.4.2 Exploitation Permits

PEs are valid for 30 years and renewable for 15 year periods until the end of the mine's life, provided the conditions laid out in the 2002 Mining Code have been met. Granting of a permit is dependent on a number of factors that are defined in the 2002 Mining Code, including:

- Proof of the existence of a deposit which can be economically exploited, by presenting a feasibility study, accompanied by a technical framework plan for the development, construction, and exploitation of the mine.
- Proof of the existence of the financial resources required for execution of the project, according to a financing plan for the development, construction and exploitation of the mine, as well as the

rehabilitation plan for the site when the mine is closed. This plan specifies each type of financing, the sources of planned financing and justification of their possible availability.

- Pre-approval of the project's Environmental Impact Statement (EIS) and the Environmental Management Protection Plan (EMPP).
- Transfer to the DRC State 5% of the shares in the registered capital of the company applying for the licence. These shares are free of all charges and cannot be diluted.

The PE, as defined in the 2002 Mining Code, allows the holder the exclusive right to carry out, within the perimeter over which it has been granted, and during its term of validity, exploration, development, construction and exploitation works in connection with the mineral substances for which the licence has been granted, and associated substances if the holder has applied for an extension. So long as a perimeter is covered by an exploitation permit, no other application for a mining or quarry right can be granted within such perimeter. The holder of a PE has the right to extend its permit to include those minerals which it can demonstrate are "associated minerals". Associated minerals are those in situ minerals that are necessarily extracted simultaneously with the minerals listed in the original permit. In addition, it entitles the holder, without restriction, to:

- Enter the exploitation perimeter to conduct mining operations.
- Build the installations and infrastructure required for mining exploitation.
- Use the water and wood within the mining perimeter for the requirements of the mining exploitation, while complying with the requirements set forth in the EIS and the EMPP.
- Use, transport and freely sell the products originating from within the exploitation perimeter.
- Proceed with concentration, metallurgical or technical treatment operations, as well as the transformation of the mineral substances extracted from the deposit within the exploitation perimeter.
- Proceed to carry out works to extend the mine.
- A PE expires at the end of the appropriate term of validity if no renewal is applied for in accordance with the provisions of the 2002 Mining Code, or when the deposit that is being mined is exhausted.

4.4.3 Sale of Mining Products

Under the 2002 Mining Code, the sale of mining products which originate from the exploitation permit is "free", meaning that the holder of a PE may sell any licensed products to a customer of choice, at "prices freely negotiated". However, the authorisation of the appropriate DRC Minister is required under the 2002 Mining Code for exporting unprocessed ores for treatment outside the DRC. This authorisation will only be granted if the holder who is applying for it demonstrates at the same time:

- The fact that it is impossible to treat the substances in the DRC at a cost which is economically viable for the mining project.

- The advantages for the DRC if the export authorisation is granted.

4.4.4 Tailings Exploitation Permits

A Tailings Exploitation Permit allows the licence holder to mine and process man-made dumps on the licence area only down to the original surface. PERs are valid for an initial period of 5 years, and can be renewed repeatedly for further 5 year periods, as long as the licence holder has operated according to the requirements laid down.

4.4.5 Surface Rights Title

The DRC State has exclusive rights to all land, but can grant surface rights to private or public parties. Surface rights are distinguished from mining rights, since surface rights do not entail the right to exploit minerals or precious stones. Conversely, a mining right does not entail any surface occupation right over the surface, other than that required for the operation.

The 2002 Mining Code states that subject to any rights of third parties over the surface concerned, the holder of an exploitation mining right has, with the authorisation of the governor of the province concerned, and on the advice of the Administration of Mines, the right to occupy within a granted mining perimeter the land necessary for mining and associated industrial activities, including the construction of industrial plants and dwellings, water use, dig canals and channels, and establish means of communication and transport of any type.

Any occupation of land that deprives surface right holders from using the surface, or any modification rendering the land unfit for cultivation, entails an obligation on the part of the mining rights holder to pay fair compensation to the surface right holders. The mining rights holder is also liable for damage caused to the occupants of the land in connection with any mining activity, even if such an activity has been properly permitted and authorised.

4.4.6 Royalties

According to the 2002 Mining Code a company holding a PE is subject to mining royalties. The royalty is due upon the sale of the product and is calculated at 2 % of the price of non-ferrous metals sold less the costs of transport within the territory, analysis concerning quality control of the commercial product for sale, insurance within the territory, and marketing costs incurred in the territory relating to the sale transaction. Different royalty rates apply to different types of metals sold. The holder of the mining licence will benefit from a tax credit equal to one third of the mining royalties paid on products sold to an entity carrying out transformation of mineral substances located in the DRC. Mining royalties paid may be deducted for income tax purposes.

4.4.7 Environmental Obligations

The 2002 Mining Code contains environmental obligations that have to be met as part of the mining right application. These are the preparation of an EIS and an EMPP. The 2002 Mining Code provides for a biennial environmental audit. If a company does not pass this audit, it may lose its permit. Upon mine closure, shafts must be filled, covered or enclosed, and a certificate obtained confirming compliance with environmental obligations under the terms of the approved EIS and EMPP.

5 ACCESSIBILITY, CLIMATE, LOCAL RESOURCES, INFRASTRUCTURE AND PHYSIOGRAPHY

5.1 ACCESSIBILITY

The Project area can be accessed directly by road from Goma, the capital city of North Kivu Province.

Figure 5.1 Intersection of Bisie access road with Walikale to Bukavu national road (N3)



Source Alphamin

Figure 5.2 Bisie access road



Source Alphamin

Figure 5.3 Bridge over Biruwe River on Bisie access road



Source: Alphamin

5.2 CLIMATE AND PHYSIOGRAPHY

The climate is tropical humid with two wet seasons; April to June and September to January. The average annual rainfall is 1,300 mm, with an average temperature range of 12 °C, from a minimum of 18 °C to a maximum of 30 °C. The annual average temperature is 25 °C. Operations can carry on all year round.

Climatic data has been obtained for the town of Goma, some 180 km South East of the mine site and the source of the closest reliable data, measured at the town's airport as shown in the table below.

Table 5.1 Climate data for Walikale

Month	Jan	Feb	Mar	Apr	May	Jun	Jul	Aug	Sep	Oct	Nov
Average high °C (°F)	25.6 (78.1)	25.7 (78.3)	25.7 (78.3)	25.4 (77.7)	25.3 (77.5)	25.3 (77.5)	25.2 (77.4)	25.8 (78.4)	25.9 (78.6)	25.7 (78.3)	25.3 (77.5)
Daily mean °C (°F)	20 (68)	20.1 (68.2)	20.1 (68.2)	20 (68)	19.9 (67.8)	19.4 (66.9)	19.7 (67.5)	19.8 (67.6)	10.8 (67.6)	19.9 (67.8)	19.7 (67.5)
Average low °C (°F)	14.4 (57.9)	14.6 (58.3)	14.6 (58.3)	14.7 (58.5)	14.6 (58.3)	13.6 (56.5)	13.1 (55.6)	13.9 (57)	14 (57)	14.2 (57.6)	14.1 (57.4)
Average precipitation mm (inches)	94 (3.7)	84 (3.31)	117 (4.61)	119 (4.69)	108 (4.25)	55 (2.17)	29 (1.14)	70 (2.76)	117 (4.61)	143 (5.63)	138 (5.43)
Average rainy days	16	16	19	22	18	8	6	8	15	20	22
Mean daily sunshine hours	5	5	5	5	5	6	7	5	5	5	5

The topography comprises moderate to steep slopes, and perennial streams and rivers. The altitude in the Project area varies from 500 to 870 metres above sea level.

Bedrock outcrop is poor, with the area covered by dense vegetation. Clay (kaolin) soils and alluvium occur in the valleys, whilst the slopes are covered by a mixture of clay soils and alluvial rubble.

Figure 5.4 Steep topography and dense vegetation cover in the project area



Source: Alphamin

5.3 LOCAL RESOURCES AND INFRASTRUCTURE

Local resources in the immediate vicinity of the Project area are scarce. Basic consumables can be obtained from Goma and Bukavu. Until road access to the Project area is established, the main mode of transport to and from the Project area is by road to Osokari, then a helicopter shuttle to the Project site.

Water is available on site from springs and rivers. There is sufficient available land on the concession for potential storage areas, waste disposal areas, and processing plant sites. There is no power

availability from the national power grid in the area and power will have to be obtained from either diesel generators or hydro-electric generators. Mining personnel could be sourced from other parts of the province/DRC, with skilled operations managers sourced from the Katanga Province or internationally.

6 HISTORY

Tin bearing gossan was discovered on the Bisie ridge in 2002 and soon became the focus of large scale illegal artisanal mining. There are no records of prior ownership or historic work carried out on the concession areas.

Primary cassiterite was mined by artisanal means from two main areas, Mpama South and Mpama North, located along 1.5 km of a ridge which extends over more than 14 km over two of ABM's mining and exploration licences (PE 13155 and PR 5266). The deepest artisanal mining workings were reported from Mpama North where the main tunnel was focused on a high grade mineralized chute, locally known as the "Salon" which reached a depth of approximately 50 m.

In 2006, Mining and Processing Congo SPRL (MPC), a former subsidiary of Kivu Resources, was granted four exploration permits (PR's) within the Bisie Project area (PR 4246, PR 5266, PR 5267 and PR 5270). MPC was the first Company to be granted legal title over the area and began work at Bisie in October 2006. At the end of November 2006, MPC was forced to evacuate the project and a new team was established on site by MPC in 2008. Once again this team was forced to evacuate the site and MPC applied for Force Majeure, which was granted on 26 March 2009.

On the 9th September 2010, President Kabila imposed an outright ban on all mining activities in Walikale territory. Two days later, he suspended all exploitation and export of minerals from North Kivu, South Kivu and Maniema Provinces.

The ban on exploitation and export of minerals, together with the Dodd-Frank Wall Street Reform and Consumer Protection Act, as well as pressure from the Organisation for Economic Cooperation and Development (OECD), drove the buyers of cassiterite concentrate to buy lower volumes at lower prices.

The ban on mining and exports was lifted on 10 March 2011 although legally Bisie could not be proposed as an artisanal validation site due to the legal title held by MPC.

In August 2011, Alphamin closed its acquisition of a 70 % interest in the Bisie Tin Project. And by late 2011, Alphamin had acquired 100% of Bisie from Kivu Resources.

The Force Majeure was lifted on PR 5266 in February 2012. Alphamin, through MPC, mobilised staff, refurbished the camp, engaged the services of a helicopter for access and moving equipment on site and commenced drilling in July 2012.

In February 2015, MPC was granted a mining licence, PE 13155, over the Bisie ridge and surrounding area. In March 2015, MPC transferred a 5 % interest to the DRC State in accordance with the Mining Act in DRC. During the same month, MPC had a name change to Alphamin Bisie Mining SA (ABM).

In November 2015, Alphamin Resources Corp. announced that it had entered into an agreement with the Industrial Development Corporation of South Africa Limited (IDC) pursuant to which the IDC invested US\$10,000,000 directly in ABM, in three tranches. The final tranche was received in May 2016, and the IDC now holds 15% of the Class A shares of ABM (effective 14.25% economic interest).

7 GEOLOGICAL SETTING AND MINERALIZATION

7.1 REGIONAL GEOLOGY

The Bisie Project is underlain in part by the Kibaran Orogenic Belt lithologies, interpreted as being an inter-cratonic collision zone with different periods of extension and compression (Pearl, 2011). Units present in the area include (Figure below):

- The Paleoproterozoic (Lower Proterozoic) Basement comprising Rusizian and Ante-Rusizian units composed mainly of poorly exposed dolomites, quartzites, amphibolites, mica schists and migmatite gneisses.
- The upper Mesoproterozoic rocks (loosely termed Burundian in the eastern DRC, Burundi and Rwanda) composed of dominant micaceous schists and buff to red arenaceous phyllites with minor interbedded quartzites and amphibolites. Shales and conglomerates are also found in the upper parts of this sequence.

Figure 7.1 Regional geology with Alphamin tenement locations

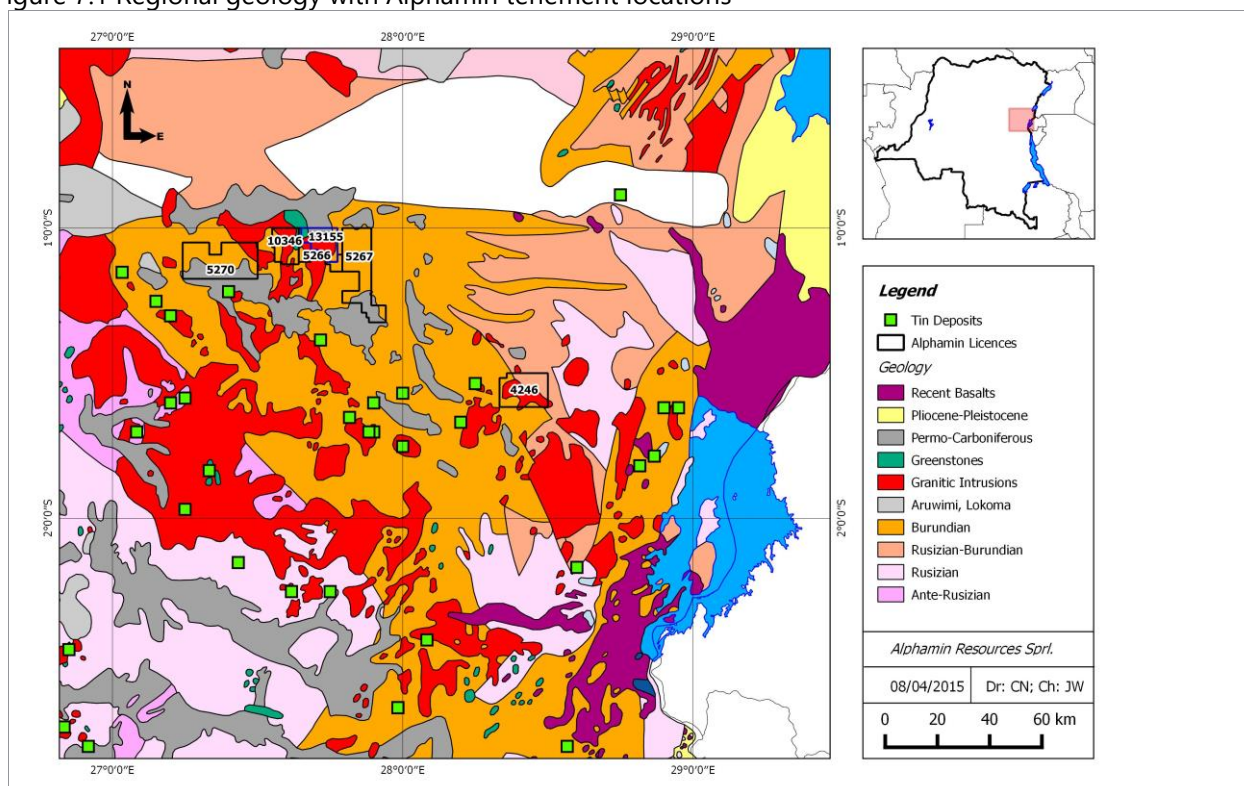

Sources: Geological map: shape file extracted from the «Carte Géologique et Minière de la République Démocratique du Congo » (Musée Royal de l'Afrique Centrale, Tervuren), Licences coordinates: CAMI.

Note: Coordinates are referenced to WGS84

The upper contact of the Paleoproterozoic basement with the overlying Mesoproterozoic sediments is poorly exposed and rarely observed, probably due to faulting complicated by tectono-metamorphic effects and granite intrusions. Both units have been intruded by different generations of granites, which started in the Mesoproterozoic ($\pm 1,375$ Ma) and continued until the last so-called "tin granite" intrusion at about 986 Ma (Neoproterozoic). These intrusions are commonly believed to be the source

of the numerous tin occurrences in the region, with the granites themselves containing elevated levels of tin. No other rock sequences such as the Lindian Group sediments or the Karoo Supergroup sediments have been identified in the area to date.

7.1.1 Structure

On a regional scale the metamorphic rock units generally strike northwest-southeast. The ridge hosting the Bisie mineralization strikes north-south as far as the Oso River in the north, after which the strike of the ridge changes to the northwest-southeast. Regional scale folding is evident in the satellite imagery (Figure below).

Structural interpretation of Landsat imagery shows numerous cross-cutting east-northeast to west-southwest trending structures. Several of these structures can be followed over several kilometres. The source of the mineralizing fluids is thought to be the massive plutonic intrusion to the west of the ridge with recent drilling and geophysics interpretation demonstrating there are multiple intrusive granitic phases, some of which are probably the source of the tin-bearing mineralizing fluids at Bisie.

Figure 7.2 Landsat image showing the limits of the granite pluton adjacent to Bisie Ridge

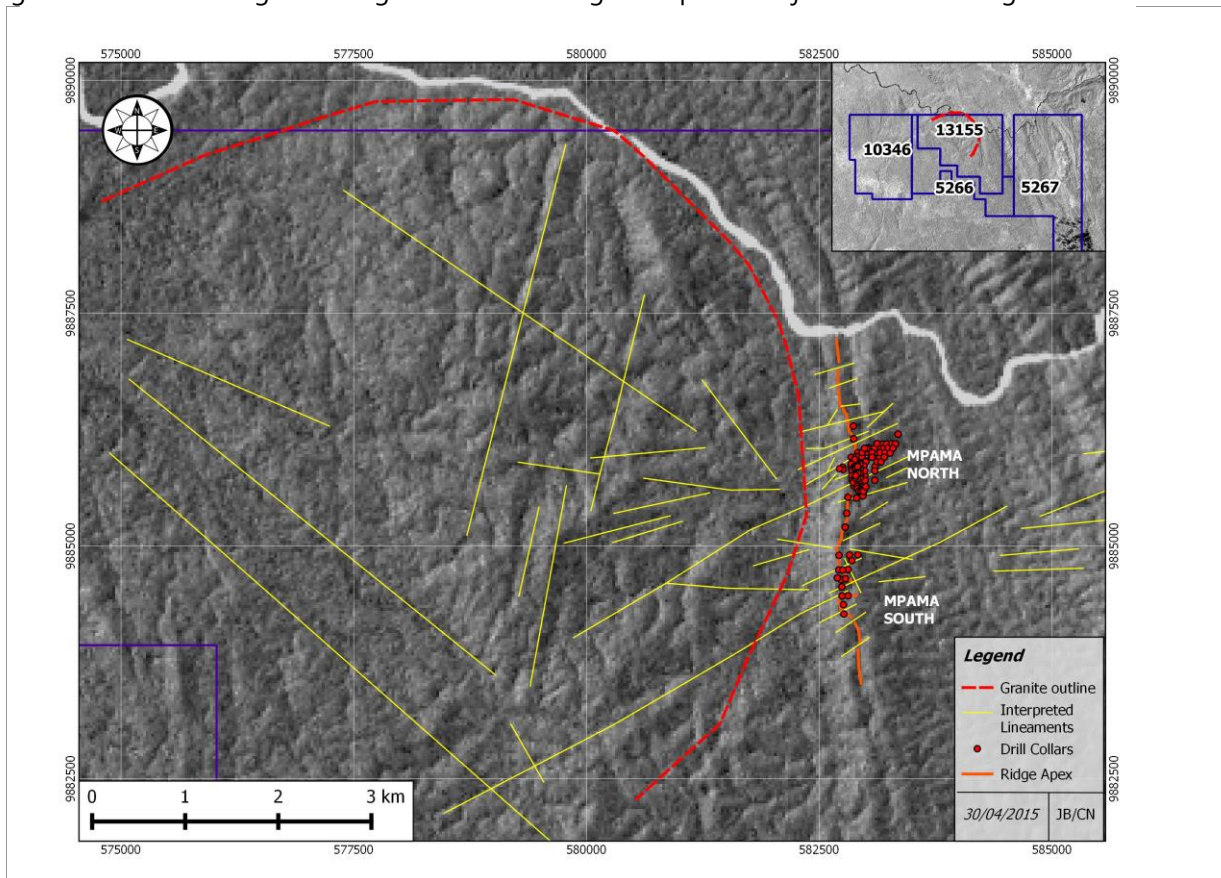

Note the Oso River running from east to west in the upper part of the Figure.

Source: Landsat data (NASA), interpretation by John Barrett. (August 2012)

7.2 PROPERTY GEOLOGY

Detailed mapping carried out between August and September 2015 included surface mapping of rock types and 3D geology modelling using drilling data along the Mpama ridge and east and west of the ridge. Given the abundance of outcrop east of the ridge line, due to extensive drill pad clearing, a

large amount of observations were made. The surface mapping data were entered into an Excel spreadsheet then plotted using GIS software Map info (Version 12.5).

3D geology modelling of drilling data was conducted section by section between 9885500N and 9886140N using Micromine 2014 (Version 15). Where mismatching lithology's were identified, drillholes were re-logged, validated and corrections incorporated into the drilling database.

7.2.1 Stratigraphy

The stratigraphic rock package hosting the Bisie deposit has been divided into five separate units (Figure 7-3).

From hangingwall to footwall, a general description of the major units is as follows:

- **Carbonaceous shale (CBSH)** – dark grey to black, thinly bedded (0.5 cm to 2 cm), fine grained, carbonaceous siltstone-shale greater than 150 m true thickness. Contains abundant quartz-tourmaline-carbonate veins and minor pyrite.
- **Meta-sediment (METS)** – pale grey, thinly bedded (0.5 cm to 2 cm), fine-grained siltstone-shale 30 m to 40 m true thickness. The host rock has been moderately silica-magnetite altered. Magnetite occurs as either discrete bands (1 cm to 2 cm), pervasive, disseminated alteration or stock-work veins.
- **Quartz-sericite schist (QSSH)** – in drill core appears more like a feldspar-rich, polymictic tuff. Pale to dark grey-green, thinly bedded (~1 cm) to massive, medium grained (1 mm to 5 mm), feldspar-sericite rich tuff 80 m to 90 m true thickness.
- **Mica schist (MSCH)** – pale to dark grey, laminated to moderately banded (0.5 cm to 5 cm), fine grained mica-rich schist 100 m to 150 m true thickness. Intensity of dark and light coloured bands varies according to biotite-muscovite content.
- **Amphibolite (AMPH)** – the current interpretation is that this unit was originally a separate mafic-ultramafic unit hosted within the MSCH overprinted with intense chlorite-talc-garnet alteration; however this has not been confirmed. Dark green to black, moderately banded (1 cm to 5 cm) to massive, fine grained to porphyroblastic (garnet), chlorite schist 20 m to 30 m true thickness. Hosts the tin and base metal mineralization at Bisie.

Figure 7.3 Bisie stratigraphic column

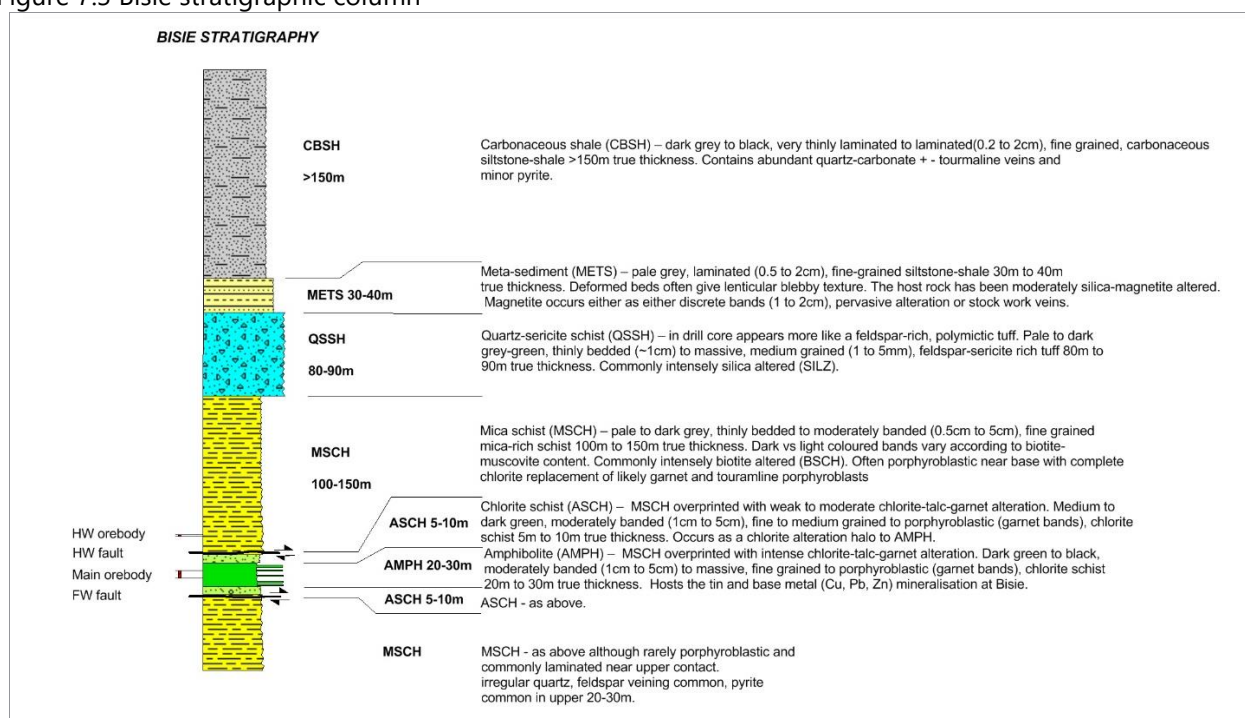

Sourced from: Alphamin. 2015.

In the hangingwall above the AMPH, within the MSCH and along the MSCH-QSSH contact is a unit commonly referred to as the upper amphibolite. This lithology does not appear to be a separate lithological unit as it traverses several lithological boundaries, forms isolated pods and lenses and is difficult to define. It is more likely related to intense chlorite alteration along isolated structures and more permeable rocks in the hangingwall of the main zone of tin mineralization.

The stratigraphic package dips east between 60° and 75° and appears to steepen down-dip and towards the east. The Mpama North ridge crest is more or less defined by the AMPH which probably resists erosion due to the massive, coherent nature of the rock and high chlorite content. The QSSH appears more susceptible to weathering and erosion due to its' high feldspar-sericite content. The base of complete oxidation (BOCO) is approximately 10 m along the ridge crest and approximately 50 m in the OSSH. Overall the BOCO averages 30 m.

The units most affected by alteration are the QSSH and MSCH particularly in the hangingwall of the tin mineralization:

- **QSSH** - contains areas where the original rock has undergone intense silica alteration (SILZ) and also intense sericite alteration of the original QSSH. To a lesser degree, QSSH is effected by biotite alteration and named biotite schist (BSCH). Where intensely chloritised the OSSH is termed amphibolite (AMPH)
- **MSCH** – is frequently termed BSCH where it comprises intense biotite alteration of the original MSCH is also referred to as amphibolite schist (ASCH) in places which usually occurs as a weak, chlorite alteration halo surrounding the AMPH.

As the alteration results in the same rock types in different parts of the stratigraphy, there appears to be an overlap between the MSCH and QSSH making the lithological boundary poorly defined in places.

To the west of the Project area, a granite pluton gives rise to subdued topography, compared with the Mpama ridge line. Mapping by ABM defined the granite as a medium-grained pink porphyritic granite, comprising predominantly quartz and pink potassium feldspar, with minor muscovite and hornblende. There is also evidence in drillhole core of propylitic alteration in some of the granites which appears to form dykes in rare instances.

7.2.2 Structure

Structure and geology surface mapping across the ridge was conducted between August and September 2015 recording in-situ lithology and structure measurements. The surface mapping was combined with drillhole geology and interpreted in three dimensions with the aim of delivering a reliable three dimensional geology and structure model to assist in Mineral Resource estimation and mine planning. Structural measurements collected in the field were plotted and draped across the DTM Lidar data and lineament interpretation was carried out using topographic highs and drainage also from the Lidar data. Faulting, foliation and quartz veining were interpreted from the field and lineament data.

The structural mapping suggests the geometry of the local structures reflects the regional scale structure, with an overall north-south trending shear zone cross-cut by east-northeast trending faults.

3D geology modelling using drillhole data identified a dominant structure comprising a brittle-ductile shear zone, with a number of hangingwall and footwall fault splays, running parallel to mineralization along the Mpama ridge. The interpretation suggests a number of the splay structures fan out towards the north while others appear to be anastomosing. South of 9885870N, the main structure occurs in the hangingwall of the deposit while north of 9885870N, the structure occurs in the footwall. Coincidentally at the cross-over point, there is a mineralized hangingwall splay (upper vein zone) suggesting the shear zone has some control on mineralization (Figures below).

Figure 7.4 Shear zone structure (blue) occurring in the Hangingwall of the Mpama North deposit south of 9885870N (red) looking west. Hangingwall vein zone shown in pink

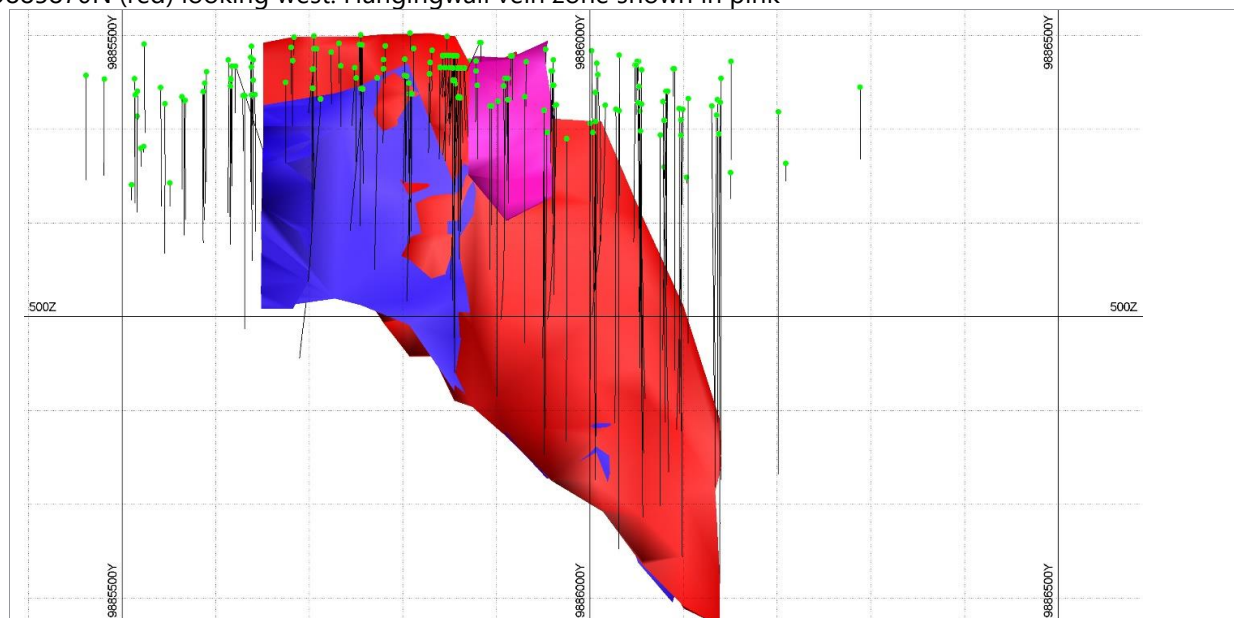

Sourced from: Alphamin. 2015

Figure 7.5 Shear zone structure (blue) occurring in the Footwall of the Mpama North deposit (red) north of 9885870N looking east

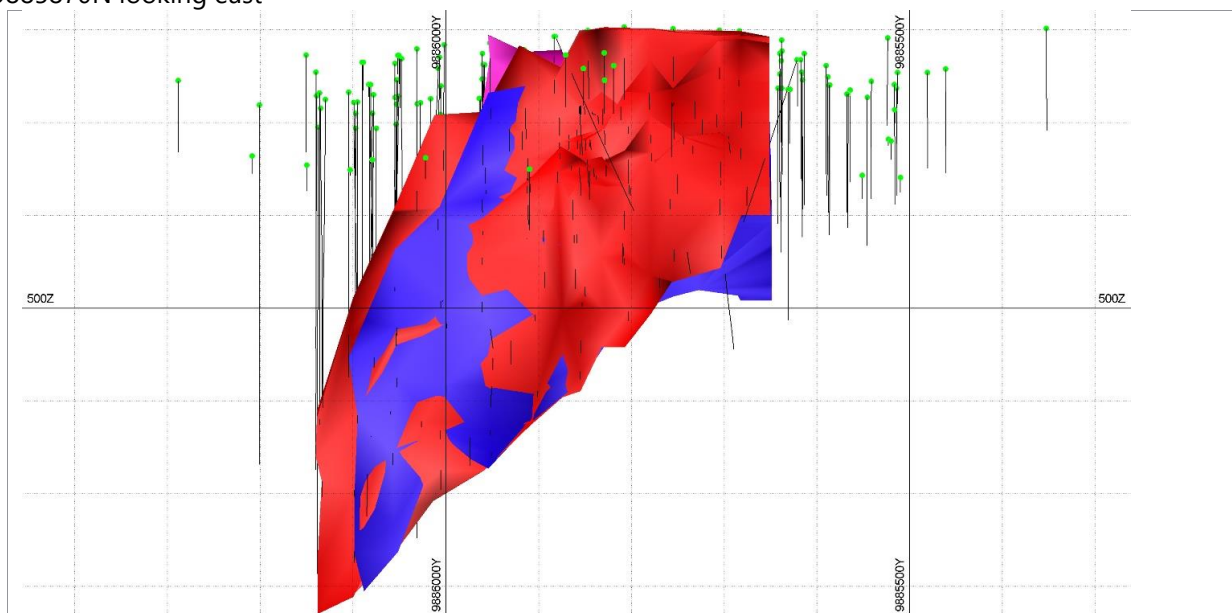

Sourced from: Alphamin, 2015

Foliation is the most common feature observed in outcrop and is a reliable indicator of folding and faulting with a change in orientation suggesting either of the two. The regional foliation strikes north-south to north-northwest, dips steeply east-northeast between 60° and 65° and is more or less parallel to bedding. Structural interpretation using stereonet also suggests that the cassiterite veins hosted within the amphibolite unit occur parallel to the regional foliation. Folding is commonly observed on an outcrop scale. 3D modelling in cross section suggests the Wedge area, at the south end of Mpama North, has been folded into a broad, south plunging (20°-25°) anticline (Figure below). The anticline structure is well represented on section 9885615N with the host lithologies in the footwall and hangingwall folded into a broad, open fold and the fold axis dipping steeply to the west. Further north and south, the fold structure weakens with the deposit becoming more tabular and dipping to the east.

Figure 7.6 Structure and geology cross section interpretation of the Wedge area at section 9885615N

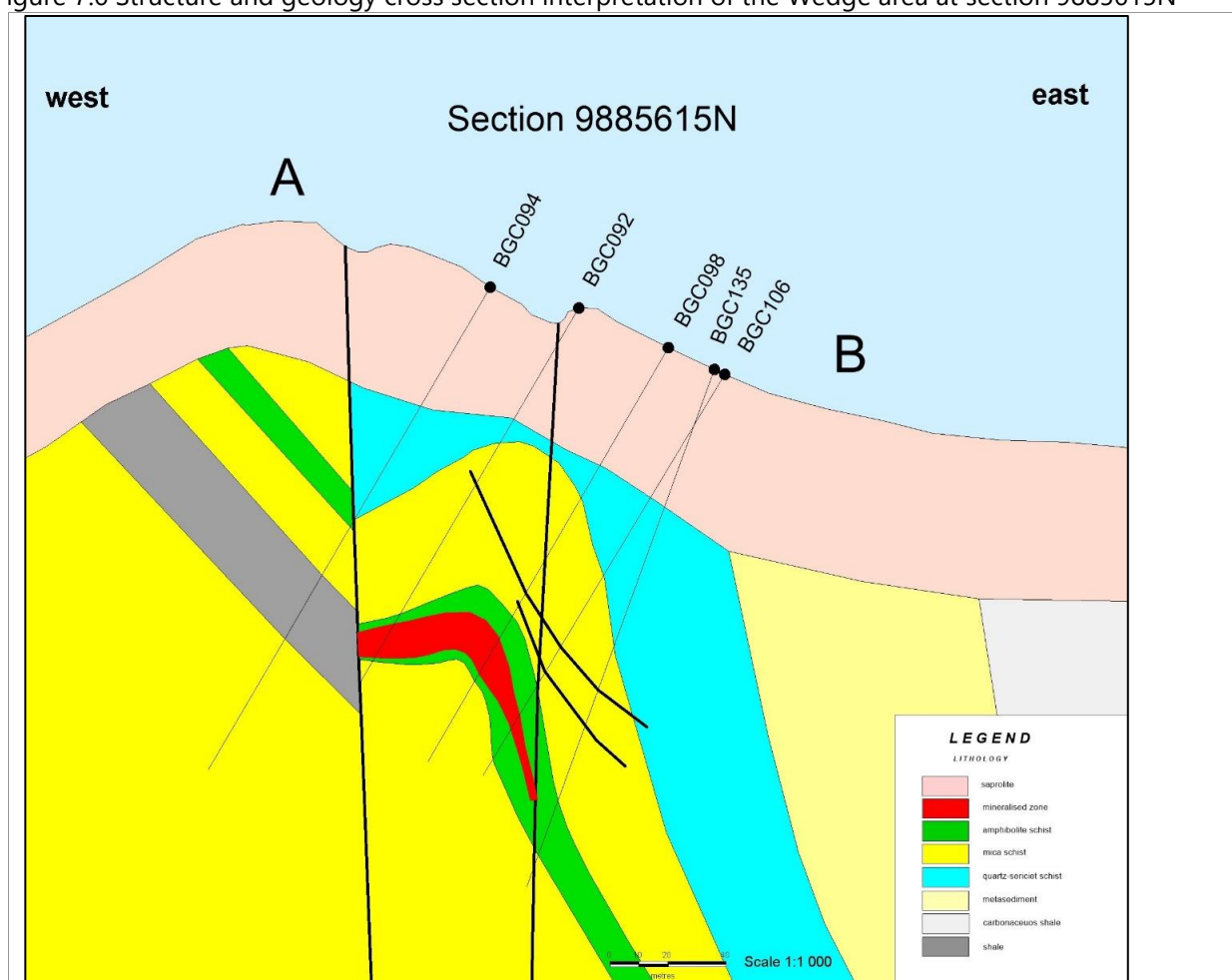

Sourced from: Alphamin, 2015

Parasitic folding is commonly seen in outcrop and in cross section interpretation from the 3D geology modelling. The folding appears to post-date mineralization with the host rock and cassiterite veins folded about the westerly dipping fold axis. In contrast to the regional foliation which dips east, the fold axis dips to the west suggesting the folding is related to a different deformation event.

Similarly to foliation, quartz veining is a good indicator of faulting and orientation of stratigraphy with foliation parallel veins provides reliable orientation data in areas of limited outcrop. A number of quartz veins were mapped in the Wedge area and at Mpama North. In the Wedge area several north-northwest trending quartz veins cross cutting the foliation were projected below surface and correlated in drill holes west and east of the mineralized zone. The western quartz vein appears to truncate mineralization up-dip and to the west and similarly the eastern quartz vein coincides with the termination of mineralization down-dip towards the east. Several quartz veins were mapped in the main area of the Mpama North deposit however these are not considered to have any effect on the geometry of the mineralization.

7.2.3 Mineralization

The bulk of the tin mineralization at Bisie is hosted within the north-south striking, east dipping amphibolite unit over 1 km to 3 km along the Mpama ridge, east of the granite intrusive. Mineralization is multi-phase and the paragenetic sequence appears similar in nature to the San Rafael deposit in Peru (Pearl, 2011; Alphamin Report, 2013).

Structural and mineralogical evidence from drill core indicates cassiterite was emplaced first, followed by copper mineralization in the form of chalcopyrite and bornite, then by lead and zinc mineralization occurring as sphalerite and galena. There is also evidence of late-stage quartz-chalcopyrite veining which cross-cuts the mineralization with veins trending north-northwest.

Chlorite alteration is widespread and appears to be the result of late stage fluids entering the system. The host rocks are predominantly highly chlorite-altered amphibolites and fine to medium grained, mica-chlorite-garnet schists. The tin and copper mineralization is predominantly found in zones dominated by intense chlorite alteration, however, cassiterite mineralization with no chlorite alteration has been intersected in the hangingwall and footwall vein zones hosted in MSCH.

The most common style of cassiterite mineralization observed in drill core comprises discrete, massive veins ranging from 2 mm to 1.80 m true thickness. Finely disseminated cassiterite is also present though less visible to the naked eye. High grade cassiterite chutes 20 m wide by 8 m thick have been historically mined by artisanal miners in the upper parts of the deposit, which most likely comprised a number of closely spaced vein sets.

The individual cassiterite veins are massive, pinkish brown, fine-grained and often botryoidal, and show compositional layering thought to be due to variations in iron content. This form of cassiterite has often been referred to as “wood tin”, as illustrated in Figure 7-7, The upper 10 m to 20 m of the mineralized veins are weathered to a porous and earthy “cassiterite gossan” or “cassiterite-in-gossan”, comprising a mixture of cassiterite, smectite clays, hematite and earthy limonite (MPC Report, 2008). The highest grade cassiterite-bearing gossans have mostly been removed by the artisanal miners.

The dominant structural control on mineralization is the north-south trending, brittle-ductile shear zone that runs more or less parallel to the cassiterite mineralized zones. It occurs predominantly as a single structure, with minor hangingwall and footwall splays particularly in the upper, more brittle parts of the structure. In the upper parts of the structure, above the 700RL, brittle fracturing has resulted in the development of up to four, lower grade vein systems whilst below the 700RL, ductile deformation has resulted in the development of a single, narrower, higher grade vein system.

Figure 7.7 Photograph of core showing the botryoidal texture of the pink cassiterite and copper sulphides (in fractures)



Sourced from: *Alphamin, 2015.*

Both tin mineralization and copper mineralization seems to be concentrated in two high grade chutes, referred to by Alphamin as the upper high grade chute and lower high grade chute. Mineralization between these two chutes is lower grade as these areas contain narrower, more widely spaced cassiterite veins. Both chutes run parallel to each other and plunge to the north at approximately 35°.

The structural controls on these chutes is not well understood but is considered to be related to the shear zone.

Copper mineralization generally occurs in close association with cassiterite. This is interpreted to be the result of continued reactivation of the brittle-ductile shear zone which facilitated the flow of copper and tin bearing fluids along a common mineralizing structure. Most of the copper mineralization occurs in the form of blebs, lenses and veins, with the latter two being sub-parallel to foliation, and a late-stage quartz-chalcopyrite vein set trending northwest. In addition to the quartz veins, chalcopyrite also occurs with pyrite and to a lesser extent arsenopyrite. Chalcopyrite and bornite also occur as fracture fillings within the cassiterite. Higher grade copper intercepts usually occur adjacent to and overlapping the high grade tin intercepts, particularly with the lower high grade chute.

In contrast to Mpama North, lead-zinc mineralization is better developed at Mpama South. Most of the zinc mineralization is hosted within massive to semi-massive pyrite in the hangingwall of the cassiterite bearing zone coincident with minor lead and silver mineralization. Small quantities of zinc mineralization are also found together with the tin and copper mineralization. The degree of galena and sphalerite replacement of the pyrite appears to be structurally controlled with replacement along late stage structures. In drill hole BGH001, the pyrite unit is crosscut by a shear or fault zone, with replacement of the pyrite being almost complete over an interval of 14 m, of which at least 6 m comprises massive sulphides. The massive zinc and lead mineralization is shown in Figure 7.8 below.

Figure 7.8 Photograph of core showing massive sphalerite (zinc) and galena (lead)

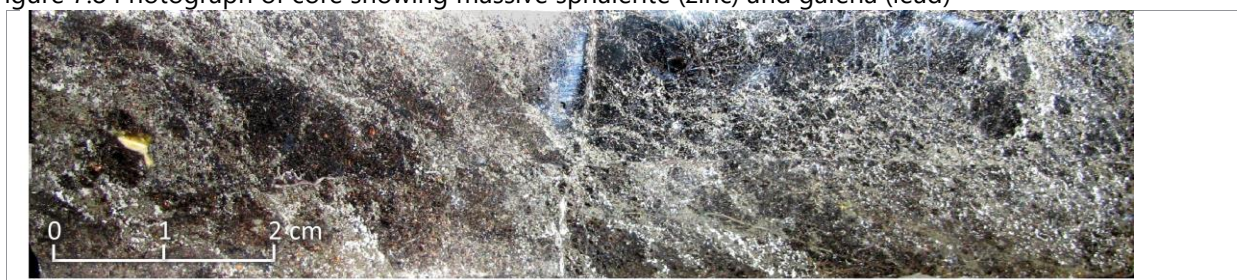

Sourced from: *Alphamin Report, 2013.*

Artisanal workings are concentrated in two areas, Mpama North and Mpama South and coincide with the highest grade outcropping tin mineralization. Drilling to date has also focussed on these two areas.

The highest grade tin mineralization has so far been found at Mpama North with cassiterite veins becoming wider and higher grade with depth. At Mpama South, mineralization appears lower grade comprising at least four vein sets, however Mpama South is not well explored, particularly in the deeper areas.

The tin-copper zone is well developed at both the Mpama North and Mpama South while the silver-zinc-lead zone is better developed at Mpama South.

8 DEPOSIT TYPES

The Bisie tin deposit is a cassiterite-bearing stock-work or vein system adjacent and possibly distal to underlying source granite. From the mineralogical composition studies undertaken by Alphamin on 38 rock and concentrate samples, it was concluded that the mineralization at Bisie is unusual and different from other classic tin deposits. The deposit has up to 0.5 % rare earth elements (REE) and very high grade tin (with some sample assays reaching greater than 60 % Sn).

From the composition of the mineralization, it was concluded that the mineralization has a low temperature origin, with a probable hidden fractionated granitic source. Fluorine and lithium are absent from the ore forming fluids and base metal sulphides scarce in the cassiterite. This may indicate the source granite to be at depth below the surface.

Three dimensional modelling of the Mineral Resource indicates that the deposit can be simply described as a number of steeply dipping tabular sheets of variable grade mineralization consisting of irregular veins and disseminations of cassiterite that is complex on a small scale.

9 EXPLORATION

9.1 RECONNAISSANCE WORK BY MINING AND PROCESSING CONGO SPRL (2006-2008)

Commencing in October 2006, MPC carried out 5 reconnaissance exploration campaigns over an eighteen month period.

On the first reconnaissance trip (October 2006), a camp was established and reconnaissance mapping commenced. Work was often interrupted by the 85th FARDC Brigade who were controlling between 300 and 400 artisanal miners. The trip was intended to locate and identify cassiterite and coltan (columbite-tantalite) occurrences and to undertake preliminary geological mapping and reconnaissance rock chip sampling.

On the second trip, a two day jungle walk was used as an opportunity to carry out field checking of the regional geology of the areas surrounding the Bisie Ridge and the artisanal workings. Further geological mapping and mapping of the artisanal workings was carried out.

Trip three entailed detailed surface geological mapping and mapping of the underground artisanal workings. The work was conducted over a 12 day period, using GPS to record topographic information and note lithological contacts. The GPS was also used to measure and map the extent of the artisanal workings at surface.

Three external geological consultants (Sam Mawson, Jerry Fiala and one consultant from SRK) accompanied employees of the MPC on the fourth trip. The consultants reviewed the existing geological data, examined the extent of the artisanal workings at Bisie and collected rock samples required for mineralogical and petrological examinations.

In April 2008, MPC undertook its' fifth reconnaissance campaign over 20 days. This included continuing reconnaissance geological mapping of the Bisie vein mineralization, checking of outcrop localities and recording new artisanal workings on the Bisie ridge and in the alluvial ground in the surrounding valleys. Several traverses were undertaken from Bisie in order to map the host rocks for some distance both to the east and west of the deposit. Despite poor outcrop, the limited exposures indicated that the dominant unit is pale blue-green micaceous schist with thin beds of grey shale, lenses of clean quartzite and elongated irregular-shaped bodies of coarse-grained amphibolite, either weathered or altered to chlorite. A small weathered exposure of quartz-feldspar-hornblende granite was noted, located approximately 4 km west of the Bisie workings. The granite is described as pink, medium-grained porphyritic granite with a slight fabric manifested by parallel elongation of the feldspar porphyroblasts.

MPC also carried out a literature search and compiled a detailed review of information lodged at the Royal Africa Museum in Tervuren, Belgium. An additional search for information was carried out at the archives in Kalima. In both cases, information pertaining to regional lithological and mineral potential was found. There was little information on detailed geology and mineralization, with only regional geological maps found. All known mineralization in the Alphamin exploration permits was discovered post-colonialism (MPC Report, 2008).

MPC purchased Landsat 7 Imagery and undertook detailed imagery interpretation. The interpretation was used to refine regional relationships between the Paleo- to Mesoproterozoic metasediments and the Neoproterozoic granites. On the existing regional geological maps, the metasediments show a

strong northwest-southeast fabric, however from the Landsat Imagery, it was noted that the regional fabric of metasediments in the middle of the permit area is north-south, complicated by the intrusion of a granite pluton. This was confirmed by reconnaissance mapping (MPC Report, 2008).

The granite contact is visible in the Landsat Imagery, approximately 3 km to the west of the Bisie workings. It is thought to be the source of the quartz veining and the associated cassiterite mineralization. The pure quartz veining and the dominant tin mineralization are considered to represent part of the last phases of post-granite metallogenesis (MPC Report, 2008).

MPC collected 38 rock samples in June 2007 as part of their reconnaissance work at Bisie, to be used for mineralogical and petrological examination. Most of the samples were collected from primary bedrock mineralization in outcrop, artisanal workings and cuttings. Additional samples were collected from weathered mineralization, fresh metasedimentary host rocks and alluvial gravels and talus slopes below the artisanal workings. These samples were sent to GET Company Ltd, Prague, Czech Republic, for analysis. Twenty-one samples were analysed for 31 elements including tin, tantalum, niobium and tungsten and rare earth elements (REE's) using ICP-MS finish on a lithium borate fused bead. Fourteen other base metals were determined using ICP-MS on a 4 acid digest. Thirty-nine polished thin sections were prepared from 24 of the samples for microscope mineralogical study. Eighteen thin sections were studied using the microprobe CAMECA SX100 at Masaryk University, Brno, Czech Republic (Breiter, 2007).

According to the studied samples, the Bisie mineralization is unusual and very different to other classic tin deposits, specifically with reference to the presence of up to 0.5 % REE and the high grade tin (50-90 % SnO₂ in some samples). From the mineral composition of the mineralization, a low temperature origin is suggested. The mineralizing fluids do not contain fluorine or lithium and base metal sulphides are scarce, suggesting a deep seated granitic source. It was thought at the time that the shape of the mineralized bodies would be irregular, making exploration using modern exploration methods difficult.

9.2 WORK CARRIED OUT ON PR 5270

Reconnaissance work has been carried out by MPC on PR 5270 which lies to the west, but not immediately adjacent to PR 5266. The reconnaissance work was undertaken in May 2008, over a period of 17 days.

In the west of PR 5270, artisanal mining of alluvial gold and cassiterite occurs along small tertiary streams which drain into the Oso River. In some locations, sand in the Oso River itself is concentrated for the "black sand" (predominantly magnetite) that contains cassiterite and fine-grained gold.

MPC visited five main artisanal mines, all located in the hills to the west of the Oso River, in the western part of the exploration permit. The mines were mapped and sampled. Fine black cassiterite occurs in quartz veins hosted in micaceous schists. A brief description of the artisanal mines is given below:

- *Carrière Mondiale:*
 - veins of over 1 m thick were observed that strike over a distance of over 100 m,
 - the veins had been mined to a depth of between 25 and 35 m,
 - in 2008 there were thirteen groups of miners, each producing approximately 120 kg of cassiterite per day, for an approximate total of 1,500 kg per day.
- *Carrière Fusio:*

- observed to be similar in shape, size, and mineralogy to *Carrière Mondiale*,
- eight mining groups were estimated to be producing approximately 140 kg of black cassiterite each per day, for a total of approximately 1,120 kg per day.
- *Carrière Bouvou*:
 - located 500 m east of *Carriere Fuso*,
 - an underground gallery of over 150 m in length had been excavated,
 - quartz veining hosting disseminated black cassiterite was visible along the length of the gallery,
 - the mine was reported to be the richest in the area.
- *Carrière Au Lieu de Zero*:
 - this is an alluvial operation in the Abenge River, a tribute of the Oso River,
 - in 2008, sand was being concentrate for the fine cassiterite,
 - four groups of miners were present, each producing approximately 50 kg of cassiterite per day.
- *Carrière Ndonga*:
 - this is an alluvial working in a small tributary stream of the Oso River,
 - mud, sand and pebble material was being sluiced by six groups of miners, each producing approximately 40 kg of clean black cassiterite per day, totalling 240 kg per day.

9.3 AIRBORNE GEOPHYSICAL CAMPAIGN

An airborne geophysical campaign was carried out over four of the licences: PE 13155 (at the time a part of PR 5266), PR 5266, PR 5267 and PR 10346. The survey was flown in six separate blocks at various line spacing, collecting magnetic and radiometric data. The survey was flown by New Resolution Geophysics (NRG), using the Xplorer system. Survey parameters are shown in the Table below.

Table 9.1 Survey parameters for the airborne geophysical survey

Survey Name	Country	Line kms	Line spacing	Line direction	UTM zone	Ave Sensor Height	Terrain
PR5266_PR10346 Block	DR Congo	2461	250m x 2500m	90	35S	28.2	Rugged
Bisie Block	DR Congo	611	50m x 500m	90	35S	31.4	Rugged
Wedge Block	DR Congo	594	150m x 1500m	90	35S	27.6	Rugged
Access Block	DR Congo	1752	50m x 500m	90	35S	28.7	Rugged
Tin Granite	DR Congo	607	100m x 1000m	90	35S	29.2	Rugged
TG2	DR Congo	109	100m x 1000m	90	35S	29.8	Rugged
Block 5267	DR Congo	2368	150mx1500m	90	35S	30.6	Rugged
Umate Block	DR Congo	457	75mx750m	90	35S	32.7	Rugged
		8959					

The data were processed by NRG and the resulting raster images were used to produce an updated geological and structural map of the area. The results were also used to delineate new potential targets by finding structures with the same magnetic and radiometric signature as the Mpama North and South prospects (Figure below).

Table 9.2 Lithological units and exploration targets delineated by interpretation of geophysical data

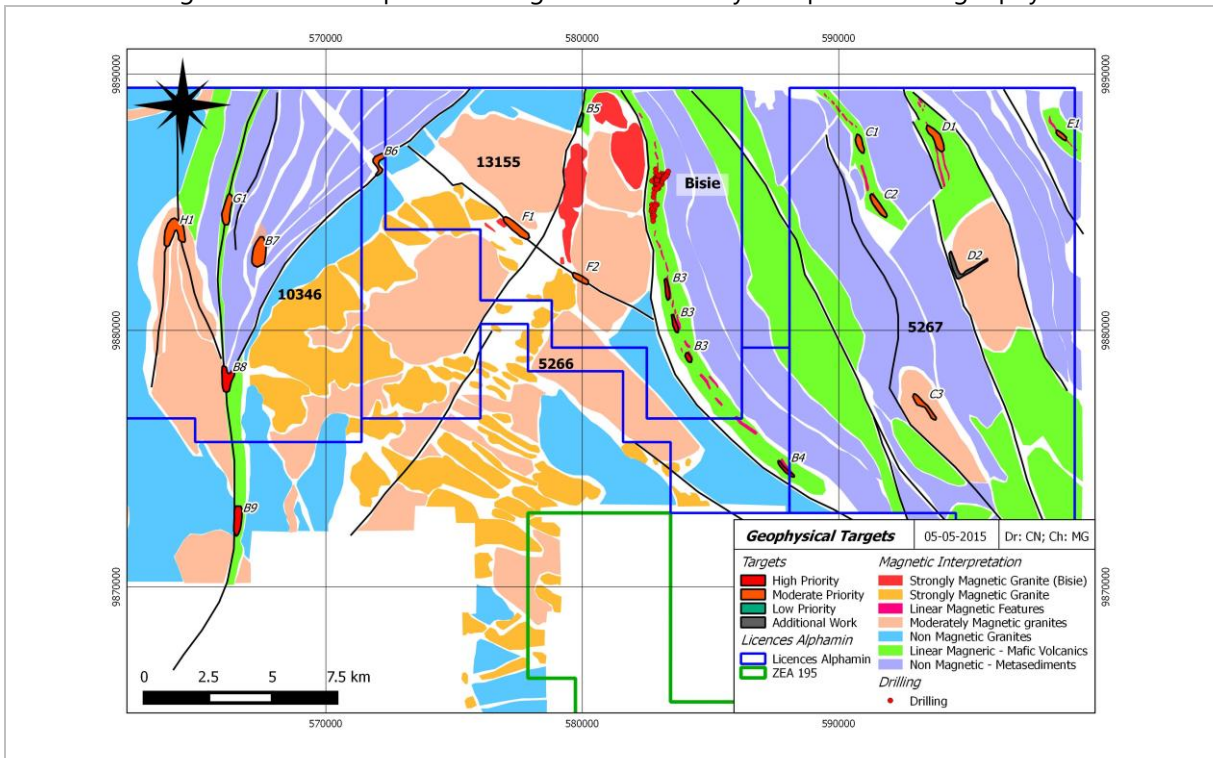

Sourced from: Geophysical data procured by NRG (2014) and interpreted by G. J. Elliott, Geophysical Consultant

9.4 SOIL GEOCHEMISTRY

Soil samples of approximately 2 kg each were collected from the B soil horizon approximately 60 cm below surface. Samples were taken at 50 m intervals along east-west lines spaced 200 m apart. All samples were air dried and sieved to -2 mm and then -180 µm before being analysed on site using a Niton hand held XRF analyser. Approximately 100 g of the sample of sieved soil passing 180 µm was placed in a plastic zip lock bag. The sample was placed on the Niton stand and analysed using an analysis time of 30 seconds on the soil setting.

9.4.1 PR 10346

An extensive soil sampling campaign was completed on PR 10346. The campaign has been designed to test the western ridge of the large pluton in the Mabeka region, situated between PR 5266 and PR 10346, where a series of targets have been defined using aeromagnetic and radiometric geophysical data (Figure below).

A total of 3,590 samples (including 80 duplicates) have been collected from five different areas, and were analysed with a Niton hand held XRF analyser. Copper, lead and zinc anomalies are weaker and less developed than those delineated on the Bisie ridge. Except in a few samples, tin values are close to the Niton detection limit and no coherent tin anomalies could be identified using this method.

Figure 9.1 Soils sampling campaign at Mabeka on PR 10346, showing results of Pb Niton analysis

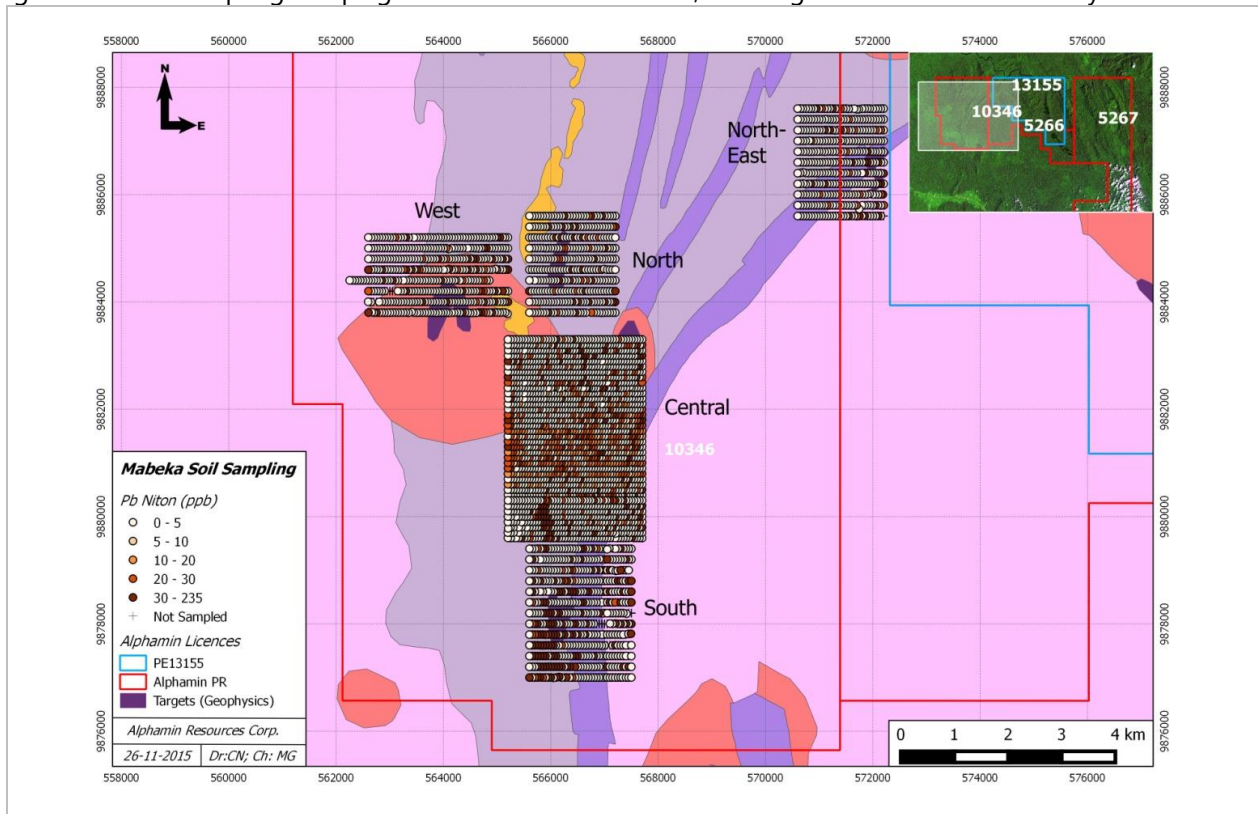

Sourced from: Alphamin

9.4.2 PR 5266 (PE 13155)

Results from the previous soil sampling program on this permit indicated a significant (> 50 ppm) lead in soil anomaly extending north and south along strike of Mpama North over a length of approximately 6 km. The sampling was extended to cover the entire length of the ridge on Licence PE 13155 and PR

5266 (Figure 9-3). 1,040 samples were collected and analysed with the Niton XRF, revealing that the lead anomaly previously delimited extended all the way to the southern end of the ridge. A copper anomaly increases in strength at the southern extension of the ridge.

A selection of 229 soils samples were sent to the SANAS accredited ALS-Chemex Laboratories (ALS) in Johannesburg for tin analysis in 2014, as the Niton detection limit for tin is too high to determine accurate tin concentrations in soil samples. The results showed a >20 ppm tin in soil anomaly coincident with the lead anomaly in places. A further 753 samples were selected and analysed in 2015, showing that the tin anomaly extends over the entire length of the ridge (Figure below).

Figure 9.2 Copper and tin in soil anomaly on Bisie Ridge

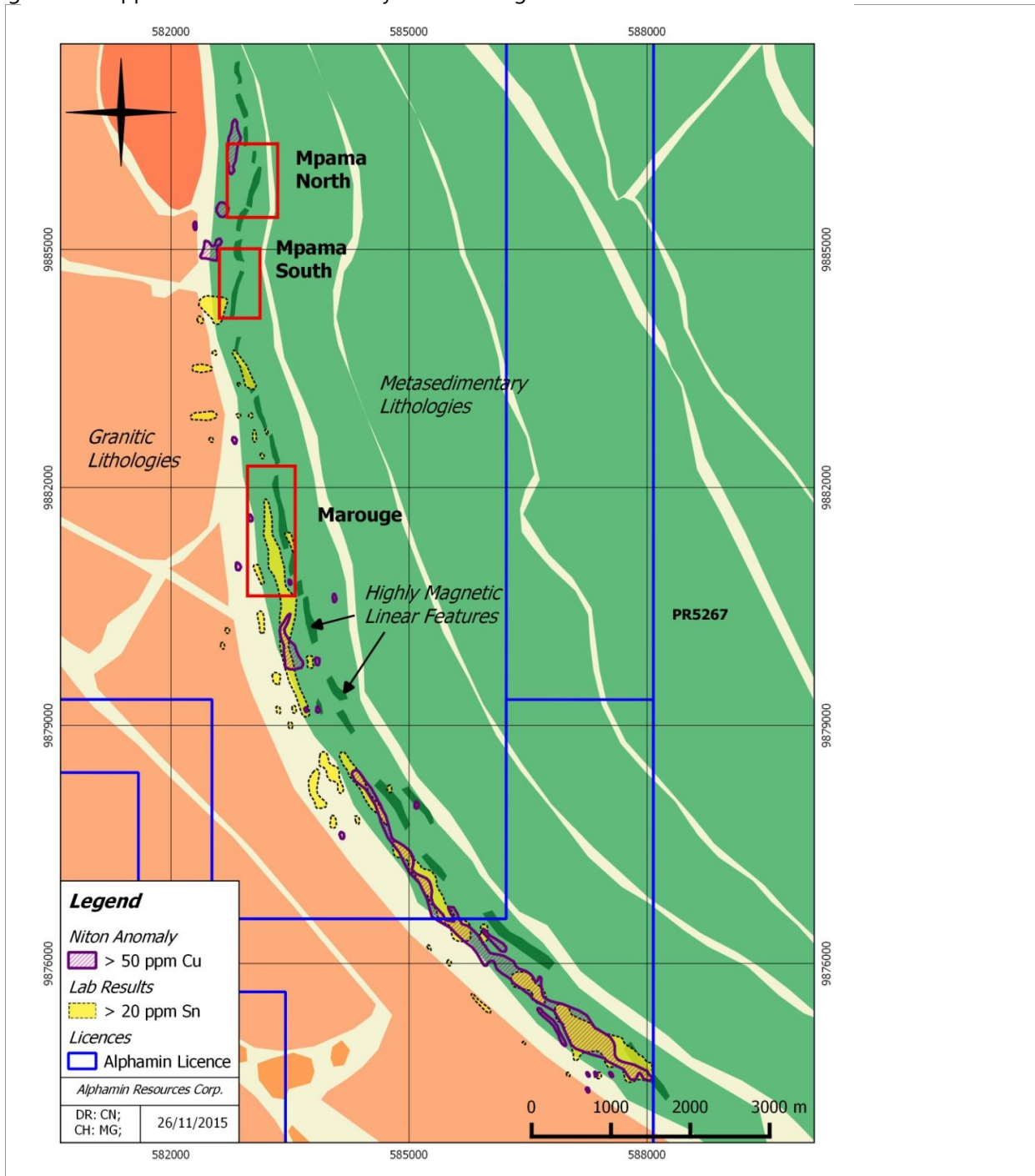

Sourced from: Alphamin.

The Niton analyses were verified by laboratory assays conducted by ALS in Johannesburg in 2014. A four acid digest and ICP-AES finish was used to analyse 100 soil samples for a suite of 33 elements including base metals. The laboratory results confirmed the anomalous lead and arsenic values, but indicated that the Niton analyses tended to be lower than the laboratory results (Figure below). Poor correlation was found between the Niton and the laboratory analyses for copper and zinc and hence the Niton analyses for these elements were found to be of limited use.

Figure 9.3 Comparison between laboratory and Niton soil analyses

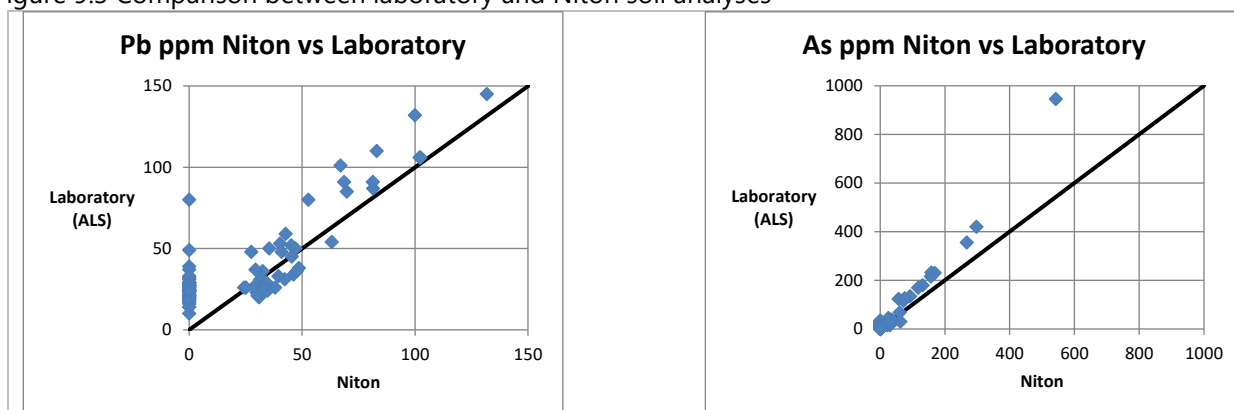

The use of the Niton XRF for soil sample analyses is a cheap and efficient method of determining anomalous concentrations of lead and arsenic in the soils as an exploration tool, the results of which are suitable for generating drill targets or areas of interest for further scrutiny.

A later soil sampling campaign was conducted on PR 5266 to the west of the Bisie ridge. The aim of this campaign was to test what was previously interpreted as a sedimentary lithology in between two large plutons. The Niton analyses showed some partial calibration offsets and the samples were destroyed in the course of the attack on Alphamin's camp on July 2014 before they could be re-analysed.

9.5 ROCK SAMPLE GEOCHEMISTRY

44 rock samples were collected from the area to the west of the Bisie ridge on PR 5266 and PE 13155, over the interpreted massive intrusive pluton. The samples' lithologies were mostly gneissic and granitic, with one mafic and one quartzite sample. These samples did not show significant tin content, but provided an insight into the geochemistry of the massive intrusion.

9.6 STREAM SEDIMENT SAMPLING

26 stream sediment samples were collected to the northwest of the Mpama North prospect. Five kilogram samples were collected and then concentrated through panning before being sent for analysis. Six of the samples reported results of over 5000 ppm Sn in concentrate. The samples were part of a sterilisation programme over potential tailings storage facility sites. Areas where positive results were achieved have been dismissed for a more favourable location for tailings disposal.

10 DRILLING

A total of 195 HQ size (63.5 mm diameter core) and NQ size (47.6 mm diameter core) diamond drill holes have been drilled on the Bisie Project to date; 171 at Mpama North, 19 at Mpama South and five at Marouge. Six of the holes drilled at Mpama North were sterilisation holes relating to planned infrastructure, 13 were geotechnical holes and one was a water monitoring hole. A further 27 PQ size (85.0 mm diameter core) holes were drilled in order to obtain a sample for metallurgical test-work.

Drillhole collars were positioned using a hand held GPS unit. Final collar surveys were completed with a digital GPS (DGPS), using reference base stations, by a certified surveyor. The final collar positions of five recent holes had not been surveyed as at the time of the Mineral Resource estimate. The collar positions of the sterilisation, geotechnical, water monitoring and abandoned holes were located by hand-held GPS.

Down-hole surveys were conducted using a Reflex EZ-Trac digital survey instrument and multi shot receiver. All drillholes were surveyed at 30 m intervals down the hole with the exception of the sterilisation, geotechnical, water monitoring and abandoned holes that were not surveyed.

Drill core was recovered from the core barrels and washed and placed into core trays at the drill site. Core recovery was measured and noted along with length of run and depth on the core blocks, which were inserted in the core trays at the end of each run. Each core tray was numbered and marked with the relevant drillhole number at the drill site. On completion of the drillhole, the core was airlifted back to the camp by helicopter where core recovery was checked during the metre marking process.

Core recovery was generally very good within the mineralized zone and country rock. Most core loss was noted in the upper 65 m and total core recovery averaged 89 %, however at depths greater than 65 m core recovery was over 95 %.

All the drilling at Bisie to date has been HQ and NQ size (63.5 mm and 47.6 mm diameter core respectively), as well as PQ size (85.0 mm diameter core) for the metallurgical sample, with diamond cored drilling inclined steeply (-60° to -75°) in order to intersect the mineralization at a high angle. The location, azimuth and dip and final depth of each drillhole are shown in Appendix 2.

Several drilling programs have been successfully completed on the Bisie prospect:

- Phase 1 - an initial exploratory program focussed on covering both the Mpama North and Mpama South prospects;
- Phase 2 - a Mineral Resource definition-based phase, concentrated on the Mpama North prospect where the tin grades returned from Phase 1 were the highest,
- Phase 3 – a later phase of drilling consisting of infill and step out drilling at Mpama North and three exploratory holes at Mpama South. Included with this drilling are the sterilisation, geotechnical and water monitoring holes. This drilling was completed in November 2015.
- Marouge – five exploratory holes to test geochemical soil anomalies at Marouge.

The initial drilling was focussed on areas of artisanal mining and along strike from these workings to test the strike extent of shallow mineralization. Later drilling has been focussed on increasing the confidence and extent of the Mineral Resource at Mpama North initially reported on 26 November 2013.

10.1 MPAMA SOUTH PROSPECT

Drilling at Mpama South (19 drill holes for 3,364 m) has been exploratory in nature and aimed to determine the extent and nature of the mineralization. Two distinct mineralized zones have been intercepted, with an upper zone showing well-developed lead, zinc and silver mineralization, and a lower zone rich in tin and copper. Figure 10.1 shows holes BGH001, 006 and 007A in cross-section intercepting the two zones. Drilling to date at Mpama South has delineated 260 m of strike returning tin intercepts of 10 m or more grading in excess of 0.7 % Sn, for example:

- 32.2 m @ 0.76 % Sn from 106.9 m including 22.05 m @ 1.02 % Sn
- 11 m @ 1.48 % Sn from 71 m, including 2.5 m @ 5.76 % Sn.
- 32.8 m @ 2.46 % Sn from 192.2 m; and
- 1.65m @ 6.57 % Sn from 320 m and 23.65 m @ 1.15 % Sn from 325 m.

Copper and rare earth element (Cerium and Lanthanum) mineralization is commonly associated with the tin rich zone, along with elevated lead and zinc. Significant results include:

- 11 m @ 0.88 % Cu from 72 m including 4.5 m @ 1.74 % Cu;
- 35 m @ 0.77 % Cu from 53 m including 10 m @ 1.67 % Cu; and
- 10.1 m @ 1,042 g/t Ce from 162 m.

Drilling further identified a zone rich in silver, zinc and lead mineralization in the Mpama South target area. Best results include:

- 19 m @ 197 g/t Ag from 61 m;
- 17.7 m @ 14.11 % Zn from 61 m including 13 m @ 18.09 % Zn; and
- 14.75 m @ 10.82 % Pb from 61 m.

A drilling program has been designed with the aim of delineating a Mineral Resource at Mpama South. This program is yet to be scheduled with the focus on the project now being on progressing the Mpama North deposit to production.

Figure 10.1 Mpama South drill collars, with significant intersects

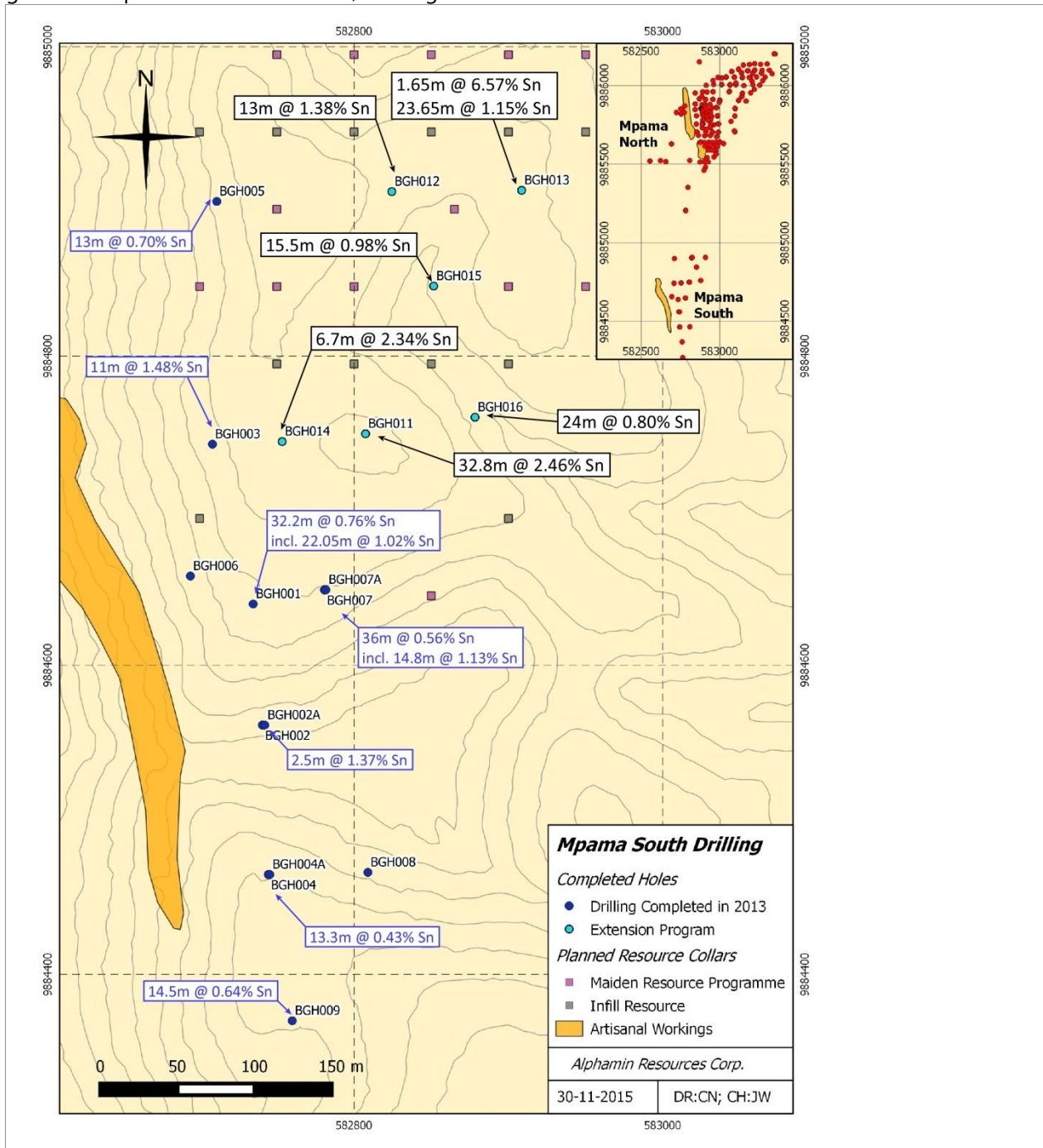

Sourced from: Alphamin

Figure 10.2 Schematic section 9884650N showing drillholes BGH001, BGC006, and BGH007 and 007A at Mpama South prospect

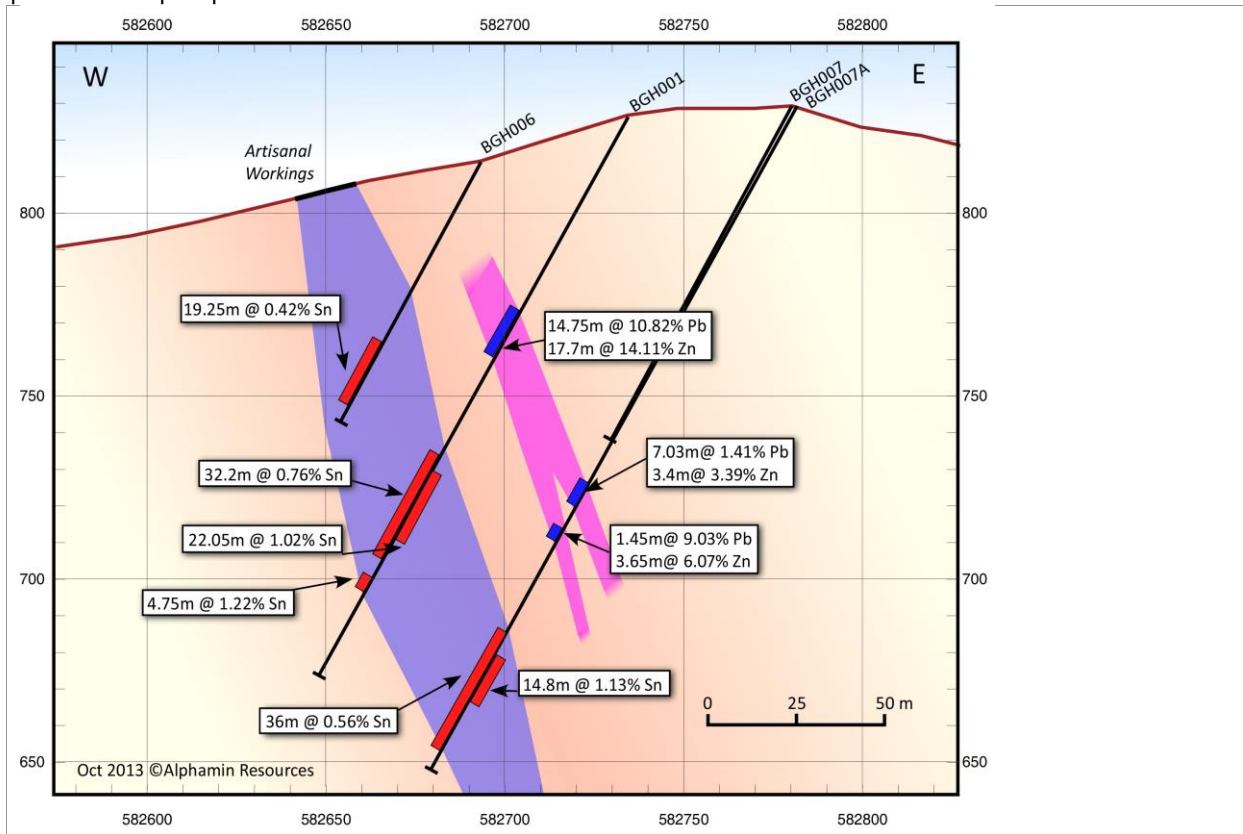

Sourced from: Alphamin

10.2 MPAMA NORTH PROSPECT

As at the effective date of this report, 34,963.55 m in 171 diamond drillholes have been drilled and logged, as well as 27 PQ metallurgical holes. The latest phase of exploration was completed in November 2015. In addition to the first 9 exploratory holes drilled during the first campaign, 28 holes (and one re-drill) were completed during the second program and 134 holes (and ten re-drills) in the latest phase of drilling. The drillholes were drilled from east to west along section lines spaced 50m apart with closer spaced drilling in the shallower areas. Along the section lines the drillholes intersected the mineralization between 25 m and 50 m apart in most of the Mineral Resource area, with drilling being sparser, up to 100 m apart, in the shallower portions of the down-plunge area.

The "Wedge" area is situated to the south of the Mpama North main zone and it was drilled at 25 m spacing along dip and strike. The mineralization appears to be offset to the east from the main zone of mineralization.

All of the available drilling results as at the effective date of this report have been included in the Mineral Resource assessment, there being no outstanding data of significance.

27 PQ sized holes totalling 2,783.5 m were drilled to obtain a metallurgical sample. Twenty four of the holes were assayed and were drilled in three clusters approximately 25 m apart. Within the clusters, the PQ holes were drilled approximately 5 m apart. The drilling at Mpama North included nine holes to investigate metallurgical variability in different locations across the deposit.

The exploration drillholes intersected variable mineralization mostly within a persistent chlorite schist unit with massive cassiterite veins hosting the majority of the tin. The structural data suggests a shallow northerly plunge, which has been confirmed by infill drilling and drilling in the down-plunge area towards the north. An example of a drilled section is shown in Figure 10.3.

Copper mineralization at Mpama North is consistently associated with tin mineralization, generally overlapping it. While copper grades are generally low, some holes returned relatively high grades. BGC035 reported 14.8 m @ 1.03 % Cu within an interval of 29 m @ 3.3 % Sn.

Figure 10.3 Schematic section 9886000N showing drillholes at Mpama North prospect

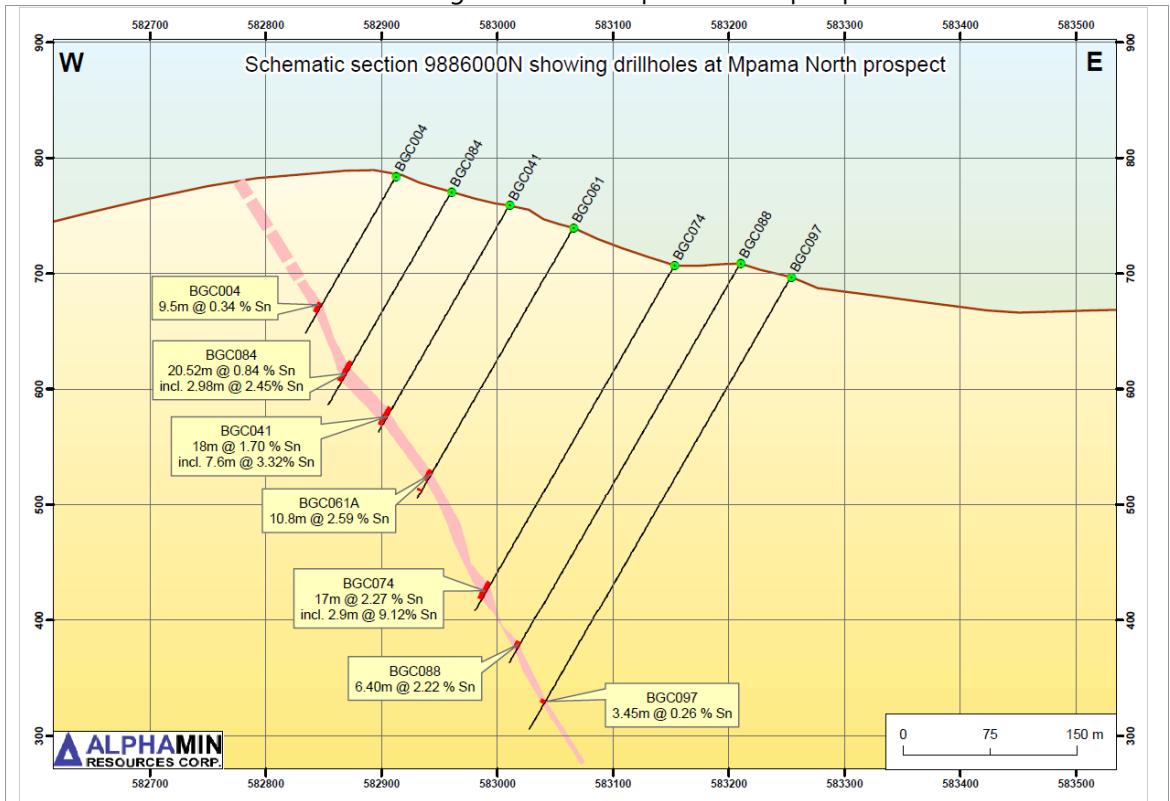

Sourced from: Alphamin, May 2016

Figure 10.4 Mpama North schematic drill hole locality map showing significant intercepts and drillhole collars and traces for Phase 1 and Phase 2 drilling

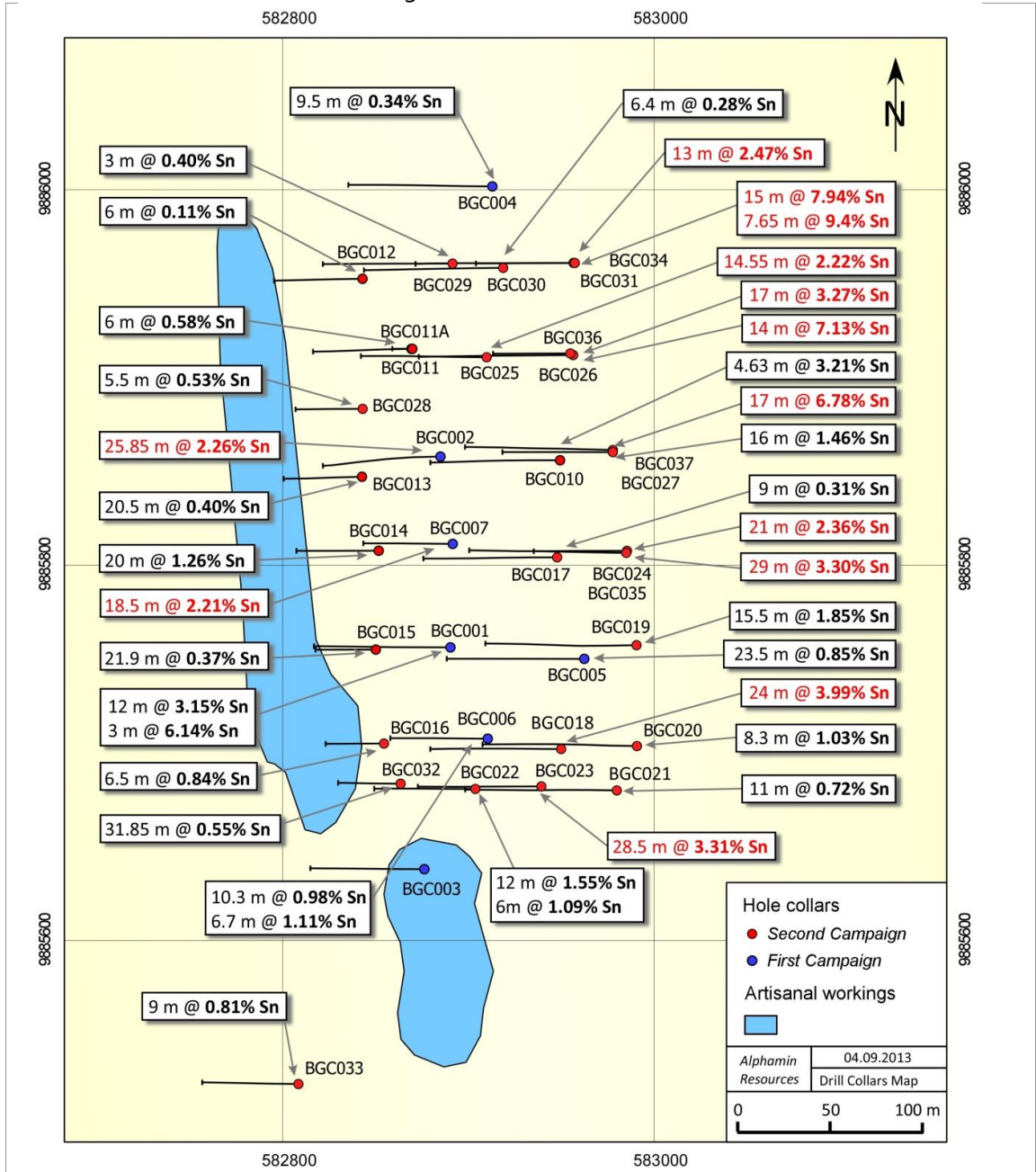

Sourced from: Alphamin, September 2013

Figure 10.5 Mpama North schematic drill hole locality map showing significant intercepts for Phase 3 drilling

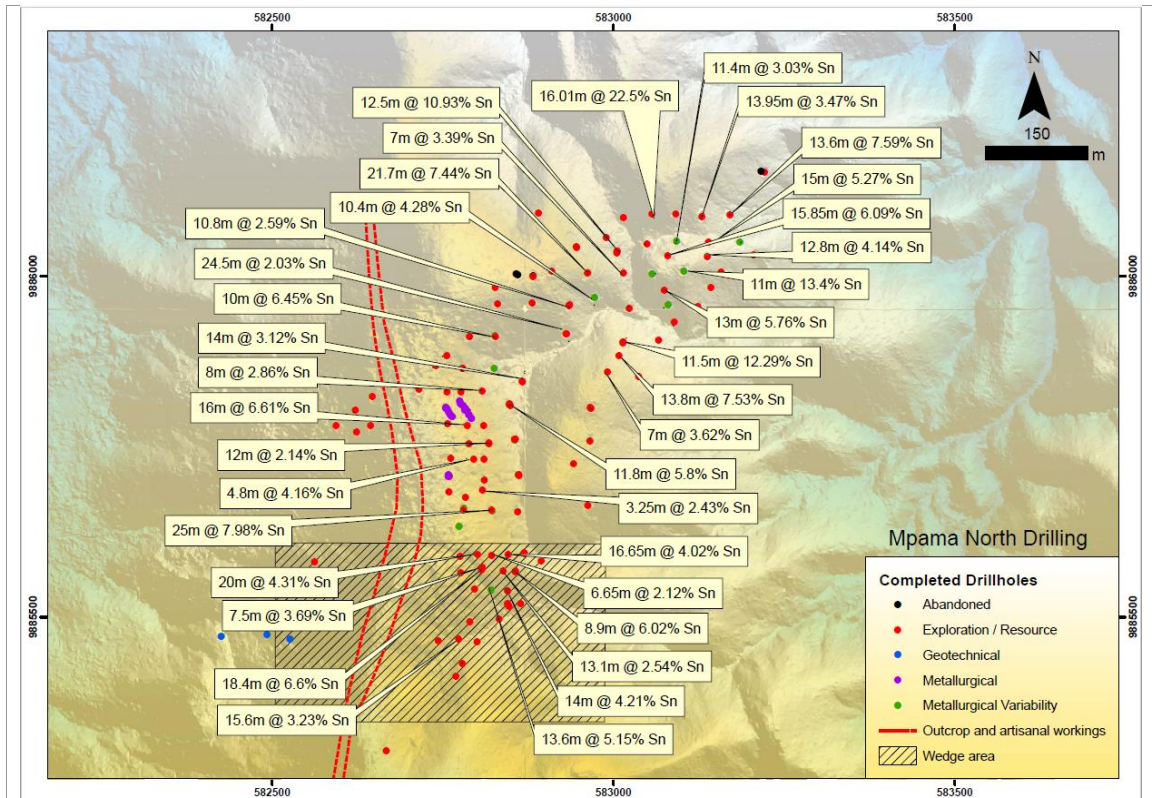

Sourced from: Alphamin, May 2016

10.3 EXPLORATION DRILLING

In the Phase 3 drilling, BGC065 and BGC075 were drilled 320 m and 170 m further south respectively from BGC033. BGC065 (drilled at -60°) intersected two narrow cassiterite veins of 1.03 % Sn over 1 m and 2.38 % Sn over 0.70 m between 61.0 m and 66.75 m. BGC075 (drilled at -60°) intersected a single cassiterite vein of 3.57 % Sn over 0.8 m at 75 m down the hole. This confirms the potential to intercept significant mineralization over the 650 m zone separating the two prospects. This could be tested further in a future drilling program.

Five holes were drilled at the Marouge Prospect, 2 to 3 kilometres south of Mpama South. No significant mineralization was intersected.

11 SAMPLE PREPARATION, ANALYSES AND SECURITY

The zones to be sampled were selected on the basis of visible mineralization and Niton XRF analysis. A five to ten metre zone, where observations and Niton analysis did not identify any mineralization, was sampled either side of any significant mineralization identified. A nominal sample length of one metre was used, which was varied in order to honour individual zones of mineralization intensity and lithological boundaries. The minimum sample length used was dependent on the nature of the mineralization with the smallest sample being 0.15 m in length, although the majority of the samples (all except 19) were at least 0.30 m long. Maximum sample lengths did not exceed 2.0 m.

After sample mark up and completion of lithological logging the core was photographed. The core was then split longitudinally in half using a water cooled diamond blade core saw along a cut line designed to separate the two halves of the core equally throughout the sample length. Core was held in closable Almonte core cutting boxes in order to reduce core loss and increase cutting accuracy. On completion of cutting of the sample, the cut core was replaced into the core tray with the half to be sampled facing upward. The half of the core sampled was the left hand side relative to the low point of the core foliation.

On completion of the cutting process, the core trays were moved to the sampling shed. The geologist or field assistant used the pre-printed sample number list to place the core samples (starting from the end of the sample and moving backward to the beginning of the sample) into pre-marked plastic sample bags. Cross checks were completed against the marked bags and sample numbers against the sample list to mitigate against sample swaps. A sample ticket corresponding to the number on the sample bag and sample sheet was placed inside the plastic bag which was then placed in the numbered sample bag along with the core sample and sealed with a cable tie.

One certified reference material (CRM) sample was inserted on average for every 30 samples, with quarter core duplicate samples (field duplicate), or an instruction for a pulp duplicate analysis (laboratory duplicate) to be performed, and blank samples being inserted at the same frequency. From BGC038 onwards (i.e. the third phase of drilling) field duplicates were no longer taken in favour of the pulp duplicates. At least one of the blank samples was inserted immediately after a high grade sample. The CRMs were sourced from Ore Research and Exploration of Australia (CRM numbers OREAS, 36, 140, 141, 142 and 163) and from Bureau of Analysed Samples Ltd of Great Britain (CRM number BCS-CRM 355). At least two CRMs, two duplicates and two blank samples were included with each mineralized intersection. Approximately 11 % of the samples submitted were used to monitor the quality of the assaying.

After final cross checking, the sample bags were tied closed using a plastic cable tie and then placed into poly-weave sacks which were in turn sealed with plastic cable ties. Each poly-weave sack was marked with a number and the sample numbers contained within, as well as the address of the laboratory.

The poly-weave sacks were then transported to ABMs' office in Bukavu or Goma via the contracted helicopter and packed into cardboard boxes which were labelled and shipped to the laboratory via air freight.

At the laboratory, samples were first checked off against the list of samples supplied and then weighed and oven dried. The dried samples were crushed to 70 % passing 2 mm, from which a 250 g split was taken and this was pulverized to 85 % passing -75µm from which a sample for analysis was taken.

Samples were submitted to the SANAS accredited ALS Chemex (ALS) laboratory in Johannesburg where samples were analysed for tin using method code ME-XRF05 conducted on a pressed pellet with 10 % precision and an upper limit of 10,000 ppm. The upper limit was reduced to 5,000 ppm from the second campaign onwards. Over limit samples were sent to ALS in Vancouver for ME-XRF10 which uses a Lithium Borate 50:50 flux to create a fused disk that is analysed by XRF with an upper detection limit of 60 % and precision of 5 %. Method code ME-ICP61 (HF, HNO₃, HClO₄ and HCl leach with ICP-AES finish) was used for 33 elements including base metals. ME-OG62, a four acid digestion, was used on ore grade samples for lead, zinc, copper and silver. Industry accepted QAQC checks were applied by the laboratory.

From January 2014 onward, high grade samples were flagged and the laboratory was instructed to clean the crushers with coarse blank after such samples. From 2015, the pulveriser bowls were also cleaned with blank material following each flagged high grade sample.

In addition to elemental analysis, ALS conducted specific gravity measurements by gas displacement using a multi-pycnometer with a precision of + -10%. Specific gravity was also carried out routinely on-site on core sub-samples using Archimedes principle of weight in air versus weight in water.

In the Qualified Persons' opinion, the sample preparation, security and analytical procedures used for the Bisie samples are adequate for the style of mineralization at Bisie.

11.1 ANALYTICAL QUALITY CONTROL AND ASSURANCE CONDUCTED BY ALPHAMIN

Alphamin has carried out quality control by the addition of blank and certified reference material (CRM) samples into the sample stream as well as duplicate analysis.

The core samples taken from the earlier drillholes (BGH001 to BGH002 and BGC001 to BGC005) did not have blanks inserted.

For the first two phases of drilling, quarter core samples were sent for assay along with the primary half-core samples, the duplicate assay immediately following the primary assay. At the end of the second phase of the exploration program, the pulp rejects were collected from ALS and 150 of these, together with CRMs, from 13 drillholes spread over the Mpama North area were sent to SGS Lakefield in Johannesburg (SGS) for check assay for tin, copper, zinc and lead. SGS is a SANAS accredited laboratory.

In the third phase of drilling (i.e. BGC038 to BGC171), the quarter core field duplicates were discontinued and only pulp duplicates were used by the laboratory on instruction from Alphamin. Although these cannot be considered truly blind sample duplicates they are useful for understanding the precision of the assaying as there is clear separation between the preparation and analytical processes at the laboratory. At least two CRMs, two duplicates and two blank samples were included with each mineralized intersection. At least one of the blank samples was inserted immediately after a high grade sample.

In 2015, pulp rejects were again collected from ALS for verification assay. 173 samples from 16 drillholes were sent for verification assay of tin, copper, zinc, lead and silver at SGS. In addition, 99

different samples were sent to Set Point (Johannesburg), which is a SANAS accredited laboratory, for verification assay of tin, copper, zinc, lead and silver. CRMs were included with the pulp rejects. In 2016, 33 pulp rejects were collected from ALS and sent for verification assay of tin at SGS.

In 2016, a total of 98 pulp duplicates were re-labelled and re-submitted to ALS for re-assay. These were from samples originally assayed by ALS in 2013 and 2014 and covered the 1.5% to 60% Sn grade range. Included with the pulp duplicates were 13 CRMs.

Approximately 18 % of the samples submitted were used to monitor the quality of the assaying.

A summary of the quantity and proportion of QAQC samples used by Alphamin, outside of the laboratory's own internal QAQC, is shown in Table 11.1.

Table 11.1 Frequency of QAQC samples used

Drillhole Number	Core samples		Blanks		CRMs		Pulp Duplicates		Core duplicates		Second laboratory assays	
	No.	No.	%	No.	%	No.	%	No.	%	No.	%	
BGH 001-009	1,005	20	2%	26	3%	16	2%	9	1%	0	0%	
BGC 001-009	546	0	0%	92	4%	57	2%	46	2%	150	6%	
BGC 010-037	2,046	87	4%									
BGC 038-146	4,174	184	4%	186	4%	140	3%	0	0%	173 @ SGS in 2015 with 27 CRMs. 99 at Set Point with 15 CRMs		
METBGC 07-27	1,002	47	5%	41	4%	35	4%	0	0%			
BGH 010-016	526	21	4%	26	5%	16	3%	0	0%			
BGC147-171	540	25	5%	29	5%	17	3%	0	0%	33	6%	

11.1.1 Results of the Blank Sample Analyses

The blank samples used at Bisie were originally sourced locally from quartz veins. In July 2013, the blanks were changed to gabbro from Bukavu. The assays indicate that the gabbro contains fairly consistent trace quantities of copper (50 ppm) and zinc (100 ppm) and so the blank was changed back to quartzite in June 2015.

Some potential contamination is evidenced by tin (less than 0.20 %). Elevated silver grades in the blank samples were more prevalent from the gabbro samples. Elevated copper, lead and zinc grades were not significant. The degree of potential contamination will not significantly affect the outcome of the tin grade estimate given the high grade nature of the deposit and that all of the contamination is considerably below the tin cut-off grades considered for this deposit. Silver and lead grades are low and local inaccuracies may arise as a result of the levels seen in the blank samples. The value of lead and silver to the project is insignificant and therefore any risk to the project is low.

Figure 11.1 Blank sample results for tin (Sn), silver (Ag), copper (Cu), zinc (Zn) and lead (Pb)

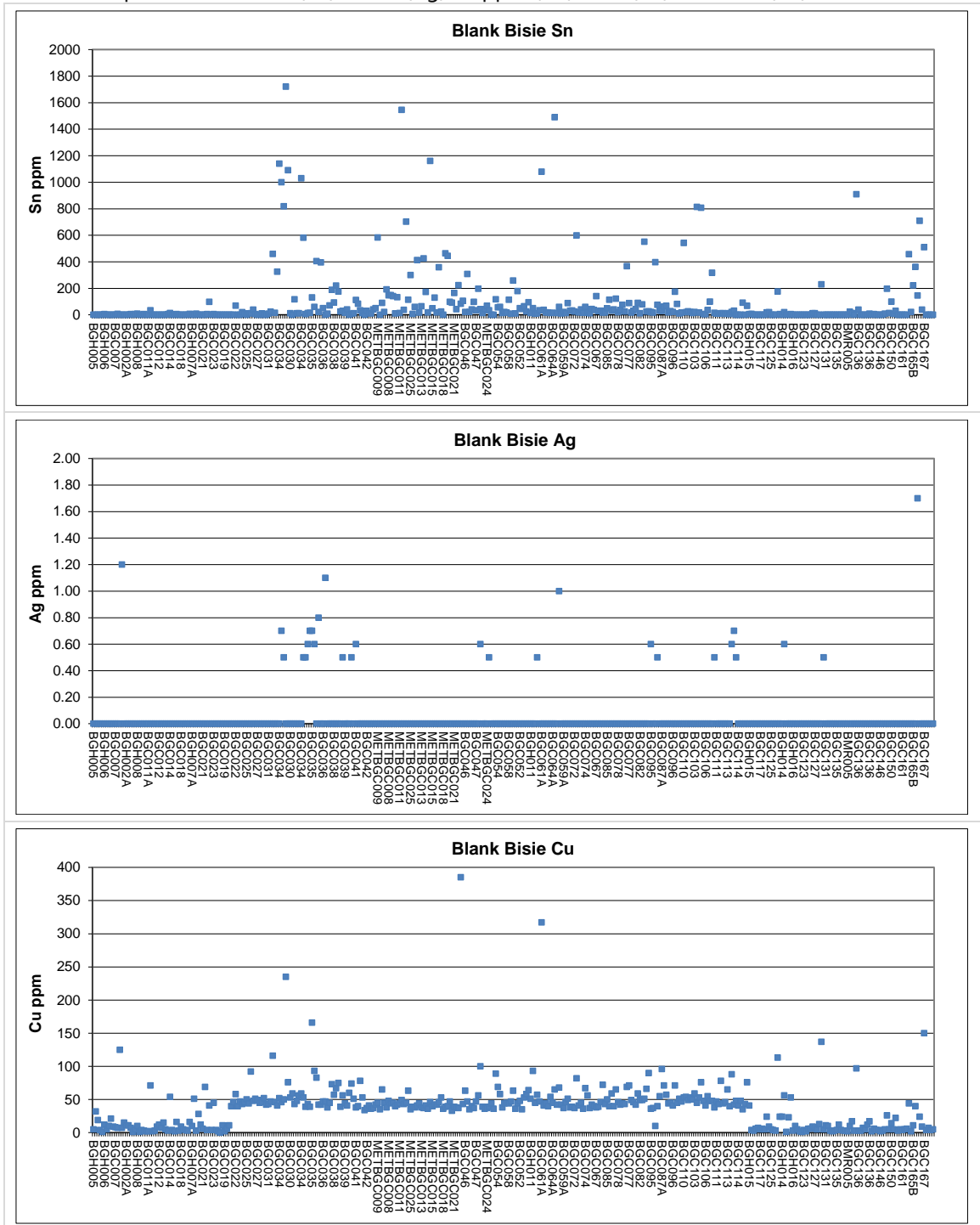

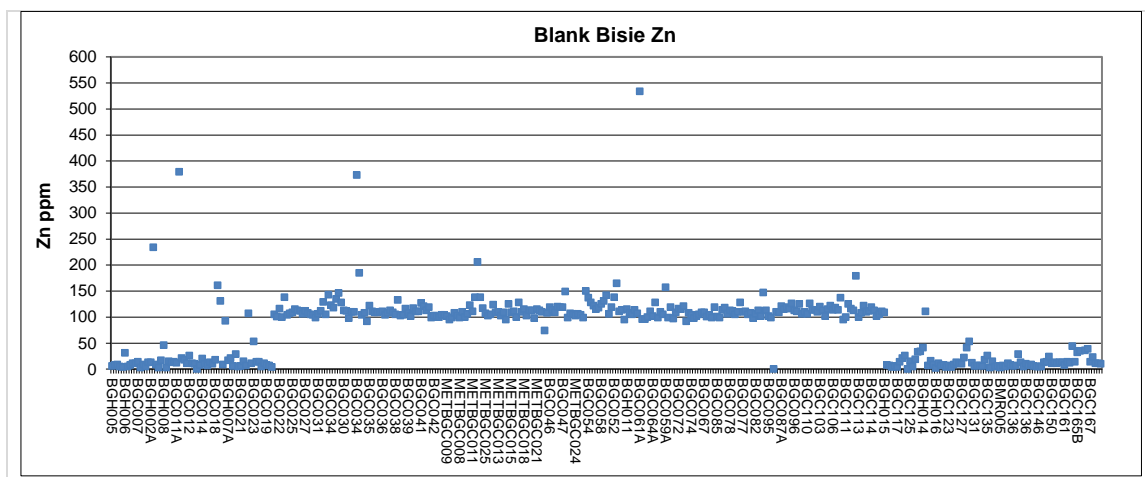

11.1.2 Results of the CRM Sample Analyses

Four different certified reference materials (CRMs) were used with tin grades spanning the range of the Bisie mineralization; however, several of the CRMs inserted in the earlier drilling phase were not of sufficient mass to be assayed for tin after analyses for other elements were complete and so tin assays were not completed for all of the CRM samples submitted. In the later phase of drilling, two additional CRMs were introduced that were not certified for tin but did between them have silver, copper, zinc and lead grades that better covered the grade ranges of these elements at Bisie.

Table 11.2 Tin grade for CRMs used at Bisie and number analysed

CRM Name	Accepted mean Sn grade (ppm)	Standard deviation	Number used	Number of Sn assays reported
BCS-CRM No355	314,200	2,200	93	86
OREAS36	Not certified for Sn			
OREAS140	1,755	122	131	110
OREAS141	6,061	339	58	47
OREAS142	10,400	500	74	64
OREAS163	Not certified for Sn			

Table 11.3 shows the certified values for the elements of interest at Bisie for the CRMs used.

Table 11.3 Certified values of CRMs used at Bisie

CRM Name	Sn ppm		Ag g/t		Cu ppm		Zn ppm		Pb ppm	
	Mean	SD	Mean	SD	Mean	SD	Mean	SD	Mean	SD
BCS-CRM No355	14,200	200	-	-	850	80	590	60	120	20
OREAS36	-	-	10.17	0.63	151	5	2,300	600	5,790	130
OREAS140	1,755	122	1.03	0.11	1,529	82	1,706	123	26.7	0.8
OREAS141	6,061	339	1.58	0.11	2,453	98	3,637	178	59	3.8
OREAS142	10,400	500	1.22	0.12	1,466	65	2,436	82	54.3	3.8
OREAS163	-	-	4.3	0.6	17,600	700	108	11	495	28

The results of the CRM assays indicate that the tin assays for the lower grade CRMs (0.18 %, 0.61 % and 1.04 % Sn) are accurate and precise. One assay for OREAS142 reported a grade consistent with that expected from OREAS141 and is presumed to have been mislabelled. One assay of OREAS140

reported 27 ppm tin, which is suspected to be an incorrectly labelled blank sample. One assay of OREAS141 reported 23 ppm Sn, which is suspected to be an incorrectly labelled blank sample and another reported 1,885 ppm Sn, which is expected to be a mislabelled OREAS140 CRM. The mean assay of the high grade standard (BCS-CRMNo355) by ALS prior to 2015 was 33.98 % Sn, which is 8.1 % higher than the accepted mean and all tin assays were well outside of the three standard deviation acceptance limit (Figure 11.2). The mean assay of BCS-CRMNo355 for the first two months of 2015 was 32.43 % Sn, which is only 3 % higher than the accepted mean. Most assays from March 2015 were close to the accepted mean and largely within tolerance, although with a slight high bias relative to the accepted mean.

Figure 11.2 CRM sample results for tin

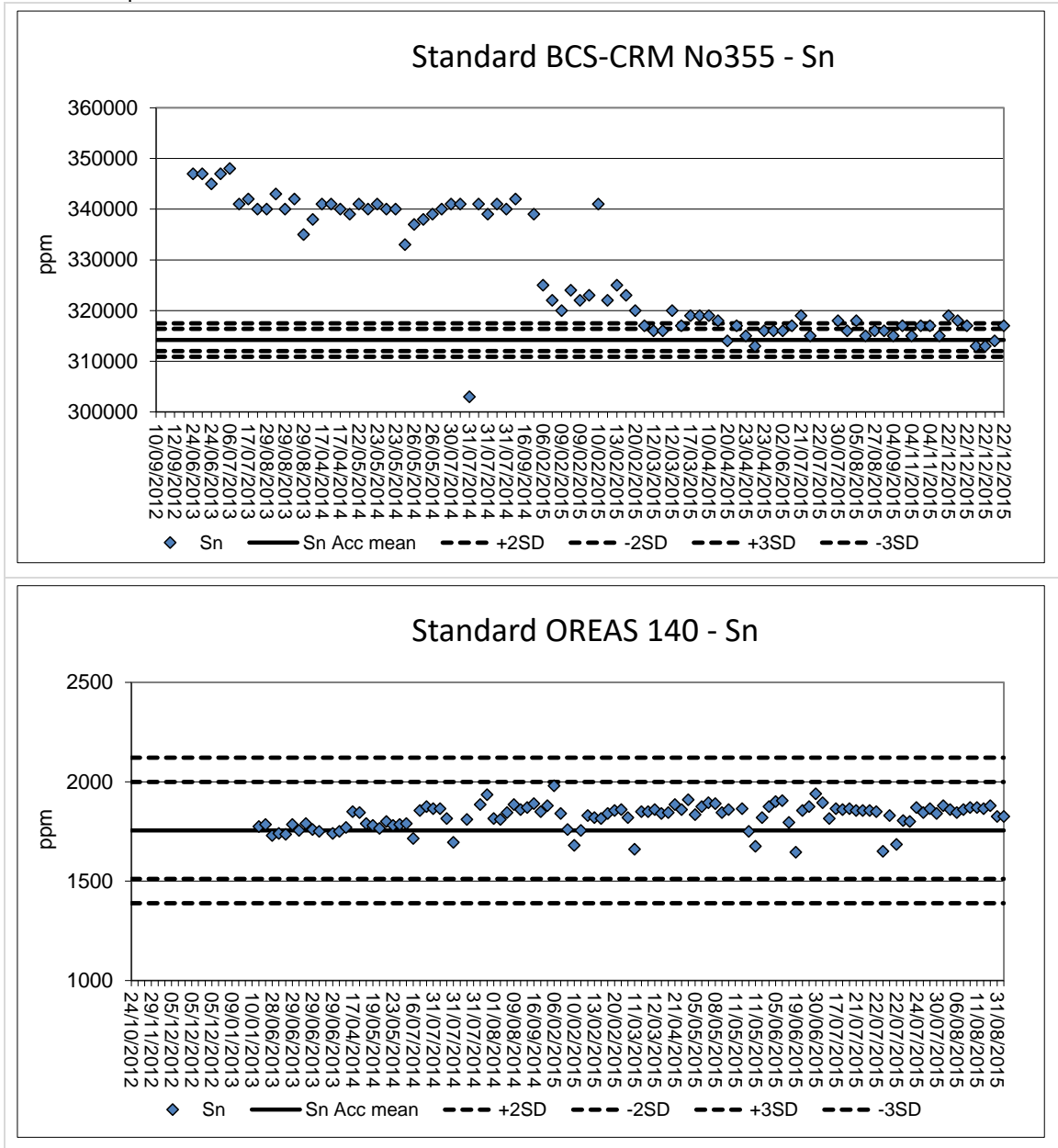

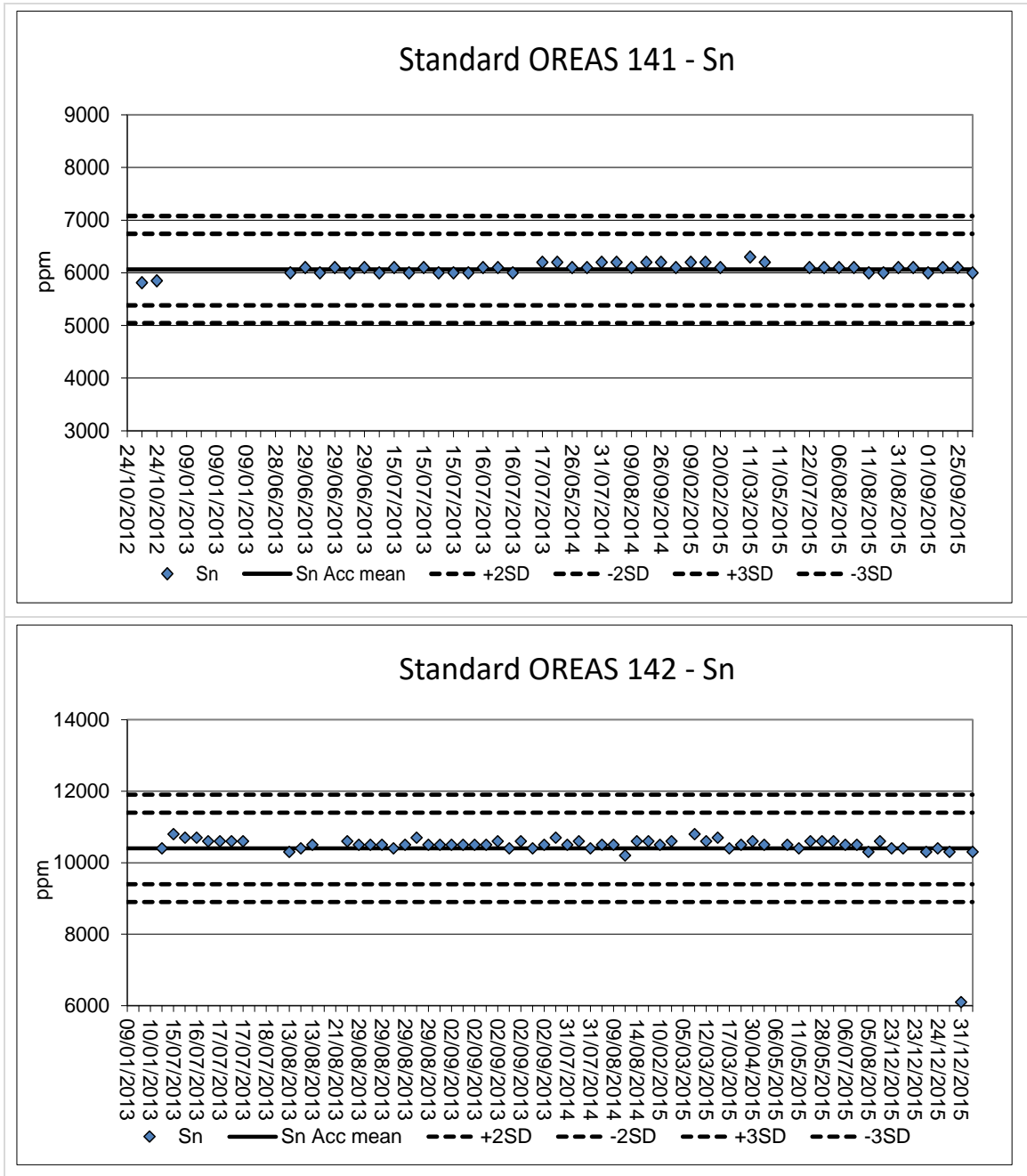

A summary of the results of the CRM analyses is shown in Figure 11.4. A failure was deemed an assay that fell outside of three standard deviations (SD) of the accepted mean value.

Table 11.4 Summary of CRM analyses

CRM Name	Sn	Ag	Cu	Zn	Pb
BCS-CRM No355	All pre March 2015 Fail Bias 8.1% high Jan-Feb 2015 Fail Bias 3% High Post Feb 2015 10/38	N/A	No failures	No failures	No failures

	Fail, slightly high				
OREAS036	N/A	No failures	1/22 slight fail, no overall bias	7/19 failed Biased low	2/22 failed Slight low bias
OREAS140	One incorrectly labelled sample.	28/107 failed. Slight low bias.	3/131 failed	3/131 failed	70/131 failed Low bias Low grade CRM – poor precision
OREAS141	Two incorrectly labelled samples.	15/56 failed. Slight low bias	3/56 failed	2/56 failed Slight low bias	10/56 failed Slight Low bias
OREAS142	One incorrectly labelled sample	5/60 failed	3/60 failed	5/60 failed – Slight low bias	13/60 failed Slight low bias
OREAS163	N/A	No failures	No failures	No failures	5/24 failed Slight Low bias

Aside from the high grade tin CRM and the high grade zinc CRM (OREAS036, large proportions of failures were noted where the grade of the CRM is low and therefore the impact on the Mineral Resource estimate is negligible.

11.1.3 Results of the Core Duplicate Sample Analyses

The 55 quarter core field duplicates showed differences in individual assays outside of more than 20 % for numerous samples. The percentage difference between the mean of the two sample sets was also high (Table 11.5). It should be noted that poor precision can be expected with small samples (quarter core) taken from the nuggety irregular vein style tin mineralization at Bisie, as also confirmed by the poor precision found with the quarter core check sample assay results. The use of coarse duplicates as a quality check was discontinued in Phase 3 of the drilling.

Table 11.5 Mean values and standard deviation of original versus field duplicates at Bisie

	Sn %		Ag g/t		Cu ppm		Zn ppm		Pb ppm	
	Mean	SD	Mean	SD	Mean	SD	Mean	SD	Mean	SD
Original	2.37	8.05	1.87	3.86	2,124	4,341	1,759	3,552	74	115
Field Duplicate	2.64	8.54	1.94	4.13	2,213	4,704	2,213	4,704	71	97
% Mean Difference	11	6	4	7	4	8	14	9	4	17

11.1.4 Results of the Pulp Duplicate Sample Analyses

Reasonable precision was noted between the pulp duplicates for high grade tin. Above 2.5 % Sn, only two out of 20 pairs had a mean difference of more than 10 % (Figure 11.3). High percentage differences were noted for tin at grades of less than approximately 0.03 % Sn. Poor repeatability was noted for

silver at grades of less than 1 g/t, copper at less than 100 ppm, zinc at less than 300 ppm and lead at less than 100 ppm. The poor repeatability at such low grades will not significantly impact the Mineral Resource estimate. Overall the average grades of the original and pulp duplicate assays were similar there being no significant bias (Table 11.6).

Figure 11.3 Pulp duplicate results

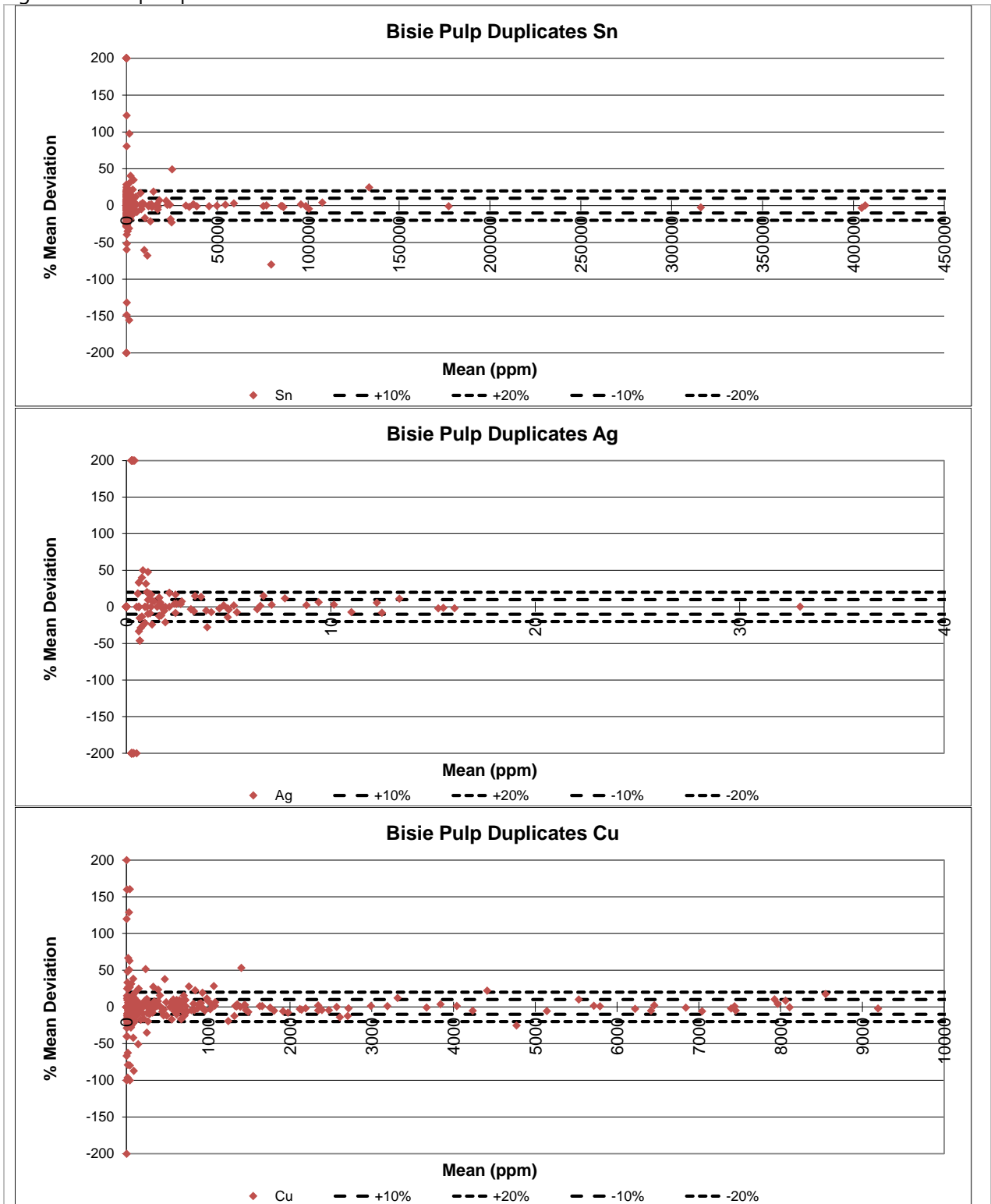

Table 11.6 Mean values and standard deviation of original versus pulp duplicates at Bisie

	Sn %		Ag g/t		Cu ppm		Zn ppm		Pb ppm	
	Mean	SD	Mean	SD	Mean	SD	Mean	SD	Mean	SD
Original	1.14	4.42	1.54	6.57	1037	2203	873	2270	120	840
Pulp Duplicate	1.12	4.36	1.57	7.11	1046	2228	870	2250	123	893
% Mean Difference	2	1	2	8	1	1	0	1	2	6

11.1.5 Results of the Second Laboratory Check Analyses

For the first and second phases of drilling, the SGS tin assays compared well with the ALS assays although they tended to be more variable, as evidenced by the slightly higher standard deviation (Table 11.7 and Figure 11.4). It is important to note that the bias noted with the high grade CRM assays was not repeated between SGS and ALS, there being no significant bias between SGS and ALS for the high grade assays. The copper assays compared well between the two laboratories. For both zinc and lead, SGS reported lower grades than ALS (Table 11.7).

Table 11.7 Mean values and standard deviation of ALS versus 2013 SGS pulp duplicates at Bisie

	Sn %		Ag g/t		Cu ppm		Zn ppm		Pb ppm	
	Mean	SD	Mean	SD	Mean	SD	Mean	SD	Mean	SD
ALS	4.28	9.94	-	-	2,874	3,937	1,381	3,248	66	99
SGS	4.30	10.49	-	-	2,796	3,930	1,269	3,221	52	61
% Mean Difference	0	5	-	-	3	0	8	1	25	47

Figure 11.4 Scatterplot for ALS versus SGS 2013 tin pulp duplicate assays

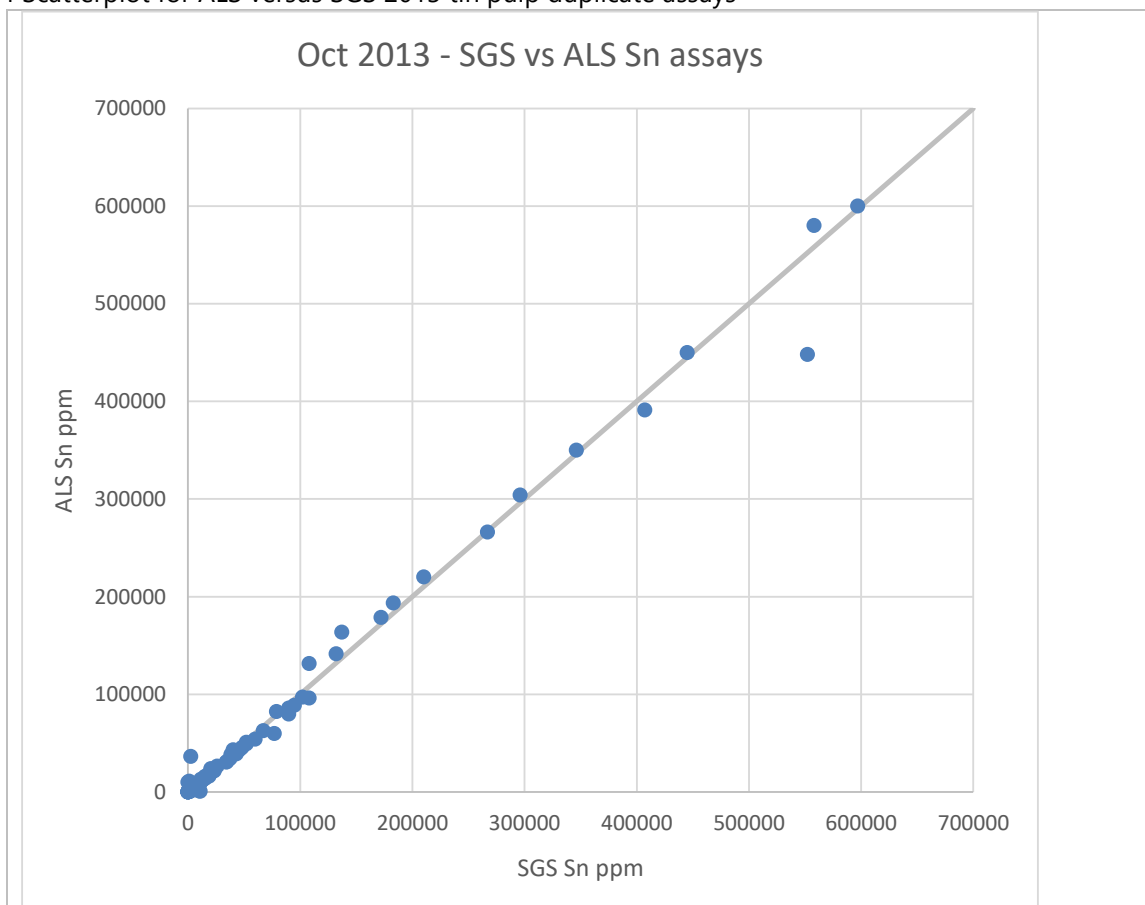

Five samples of BCS-CRM No355, OREAS141 and OREAS 142 were included with the SGS assays. These indicate that the lower grade assays by SGS were accurate, although there was a tendency for SGS to under report the high grade CRM assays, which is contrary to ALS which over assayed the grade of this CRM in 2013 (Figure 11.5).

Figure 11.5 Control chart for CRMs assayed by SGS in 2013

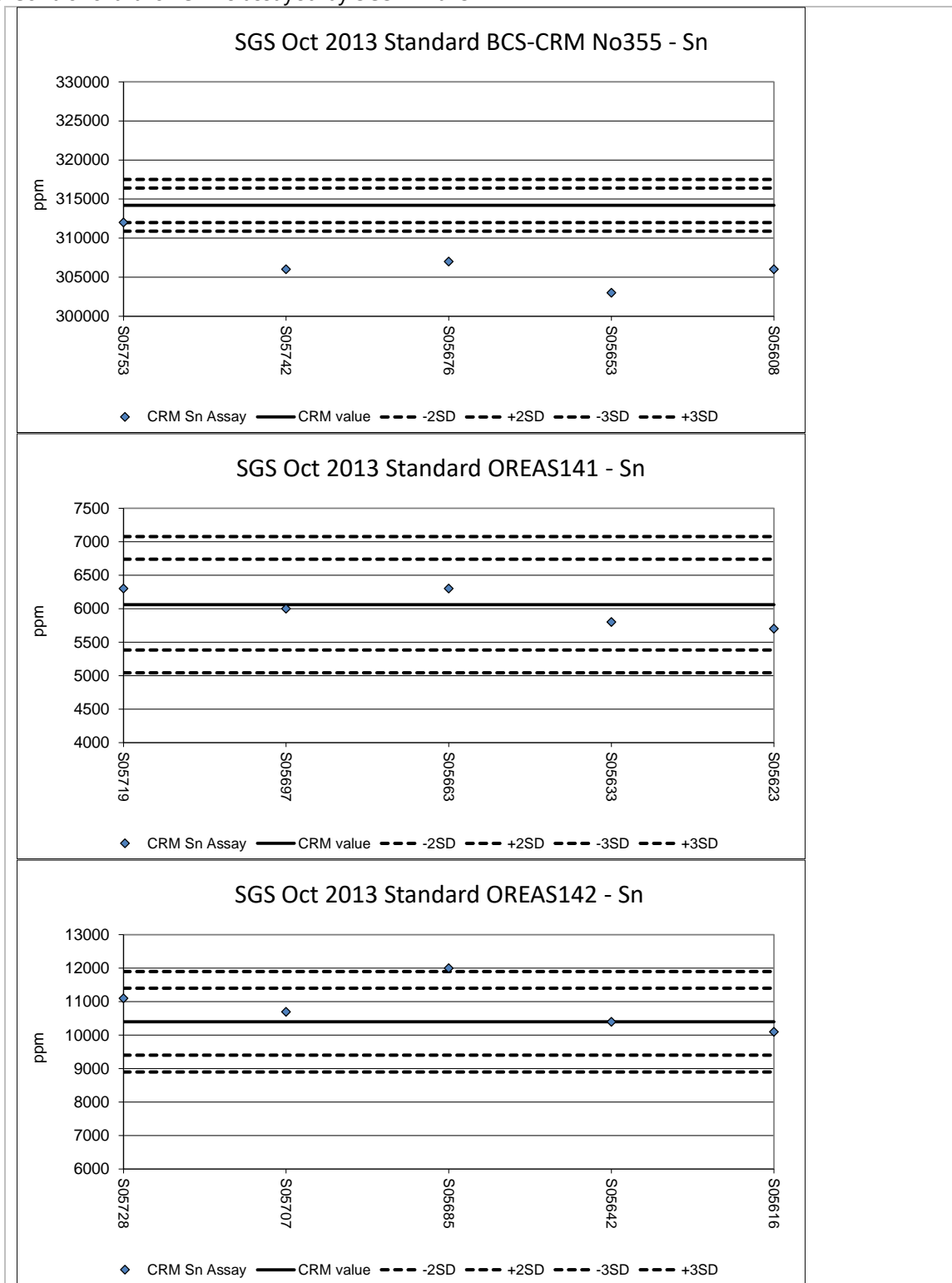

For the third phase of drilling (up to BGC075) 200 pulp samples prepared by ALS were sent for verification assay at SGS in Johannesburg. Together with the pulp duplicates of the core samples, a number of certified reference material samples were included. The SGS assays were lower than the ALS assays, particularly for the higher grade samples (above 250,000 ppm; Figure 11.6). However, this cannot be taken as firm evidence that the ALS assays were necessarily too high as SGS had a strong tendency to under-assay the CRMs that were included with the duplicate pulp samples (Figure 11.7).

There is a 6 % mean difference between the ALS and SGS tin assays. SGS zinc and lead assays are significantly higher than those of SGS and copper assays are almost the same (Table 11.8).

Table 11.8 Mean values and standard deviation in ppm of ALS versus 2015 SGS pulp duplicate assays at Bisie

	Sn %		Ag ppm		Cu ppm		Zn ppm		Pb ppm	
	Mean	SD	Mean	SD	Mean	SD	Mean	SD	Mean	SD
ALS	5.95	12.2	2.1	1.5	2,984	4,680	1,613	2,429	54	95
SGS	5.59	11.79	3.7	3.0	2,946	4,579	2,058	2,783	67	80
% Mean Difference	6	4	31	22	1	2	24	14	22	16

Figure 11.6 Scatterplot for ALS versus SGS 2015 assays of 2014 samples - tin pulp duplicate assays

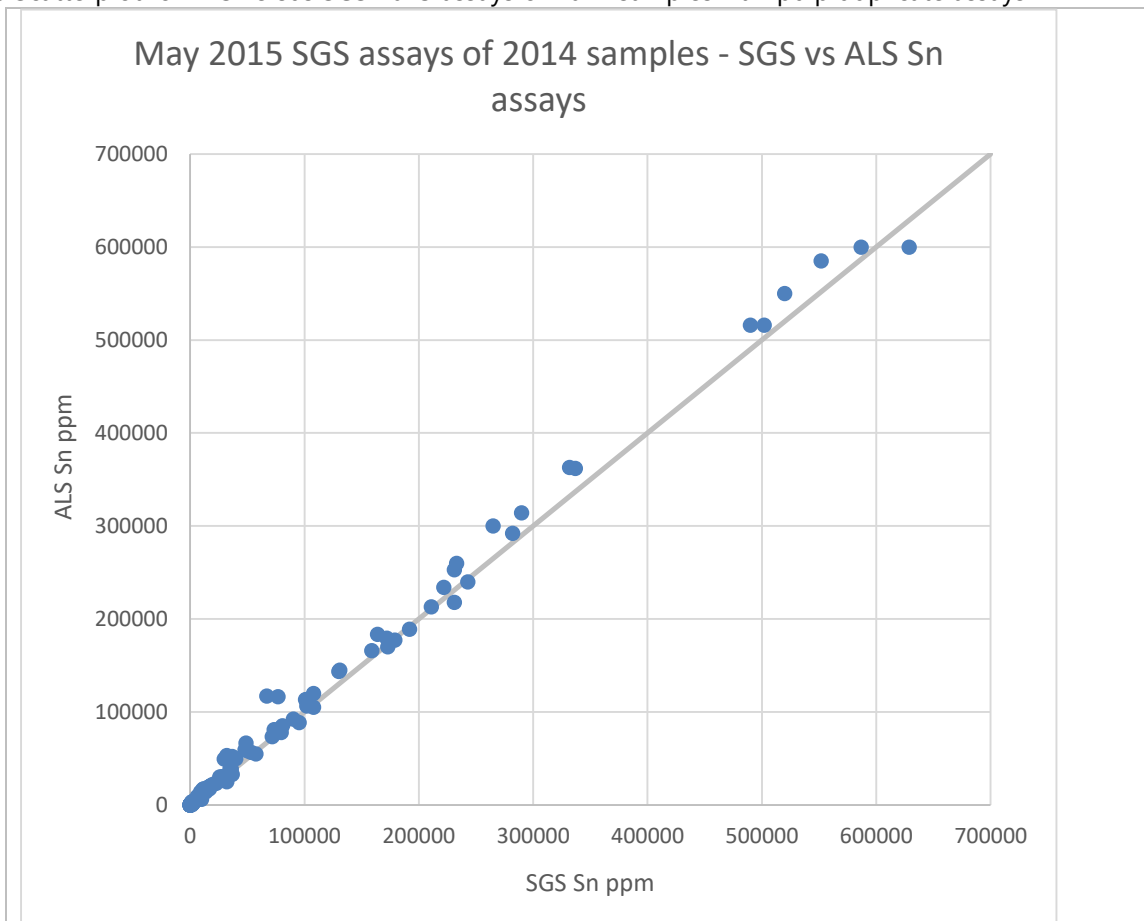
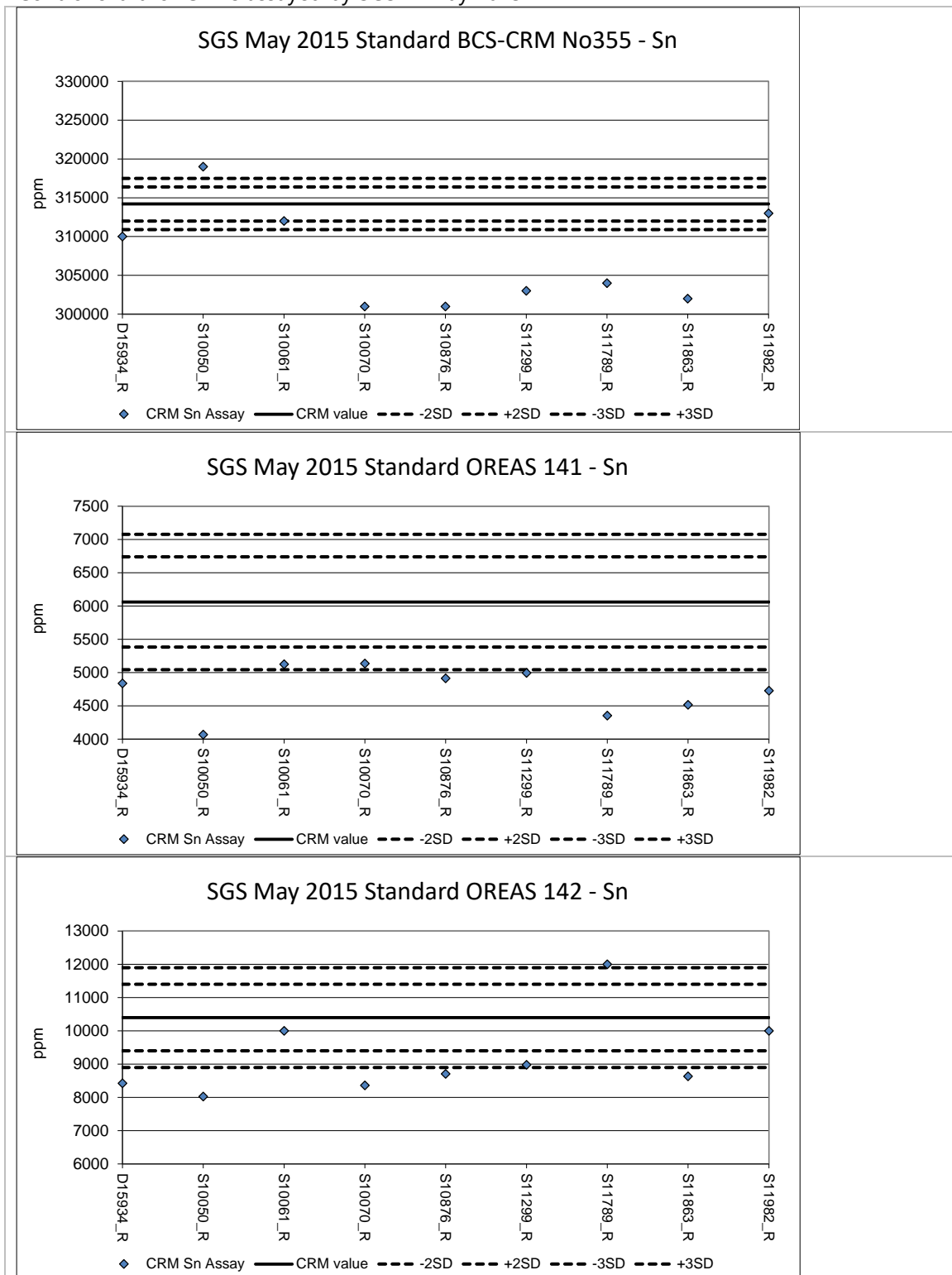

Figure 11.7 Control chart for CRMs assayed by SGS in May 2015



As the results of the second laboratory verification were inconclusive, due to the low assay bias for SGS as shown by the CRMs, a second verification laboratory was chosen; Set Point (Johannesburg), which is a SANAS accredited laboratory. The Set Point assays were significant lower than those by ALS for grades above 10,000 ppm (Figure 11.8). It should be noted that Set Point has a lower detection limit of 100 ppm for Sn and therefore all pairs were excluded from the scatterplot for which Set Point assays returned below the detection limit. For many of the assays that ALS returned values of well over 100 ppm (in many cases over 1,000 ppm), Set Point returned values below detection limit.

The two assays by Set Point of CRM OREAS140 (1,755 ppm Sn) both returned values below detection limit (<100 ppm Sn). The assays of OREAS142 by Set Point were below the accepted mean, although within tolerance. Two of the three assays of OREAS141 were well below tolerance limits and the other was significantly higher (Figure 11.9). The assays of the high grade (CRM BCS-CRM No355) returned values higher than the accepted mean with the exception of one assay that returned a low value of 212,000 ppm Sn, which may be an incorrectly labelled field sample. On the basis of the CRM assays by Set Point, the comparison with ALS is inconclusive.

Figure 11.8 Scatterplot for ALS versus Set Point 2015 assays of 2014 samples - tin pulp duplicate assays

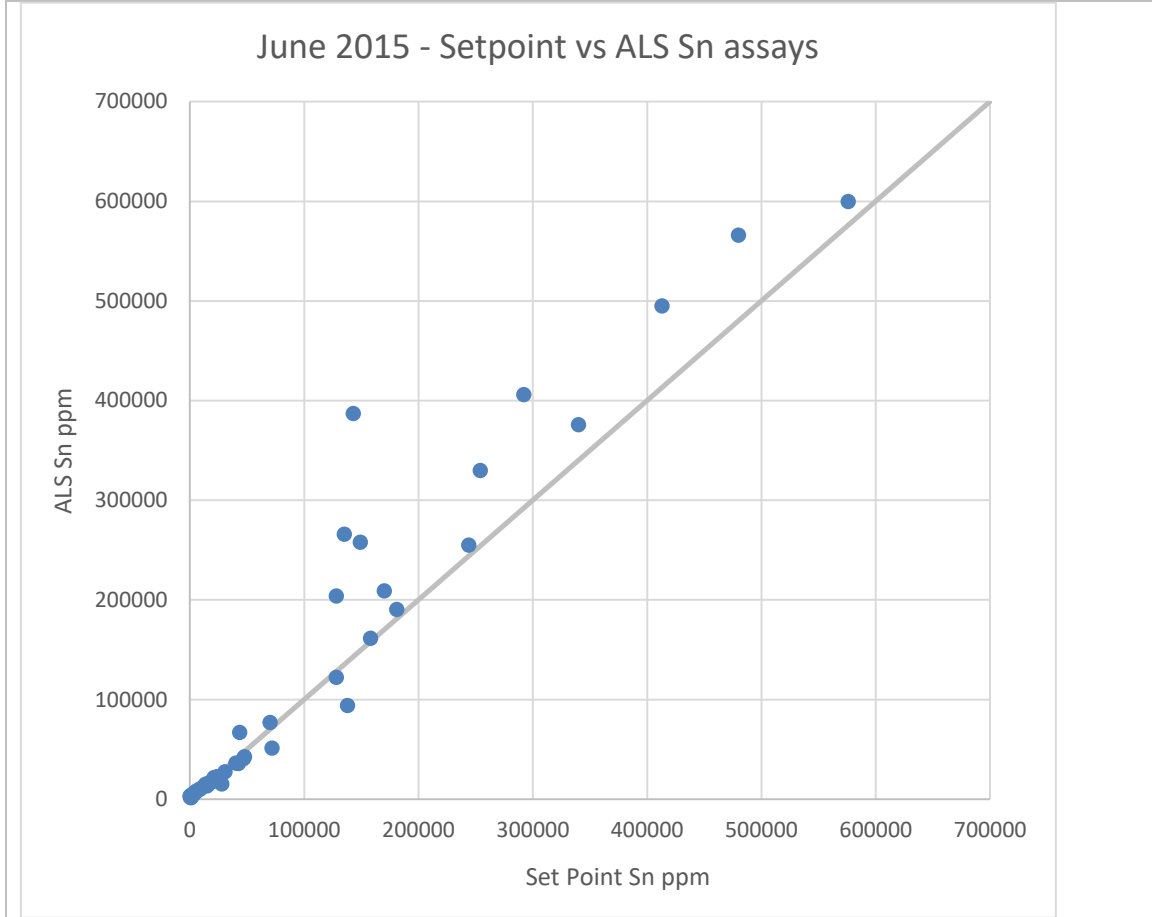
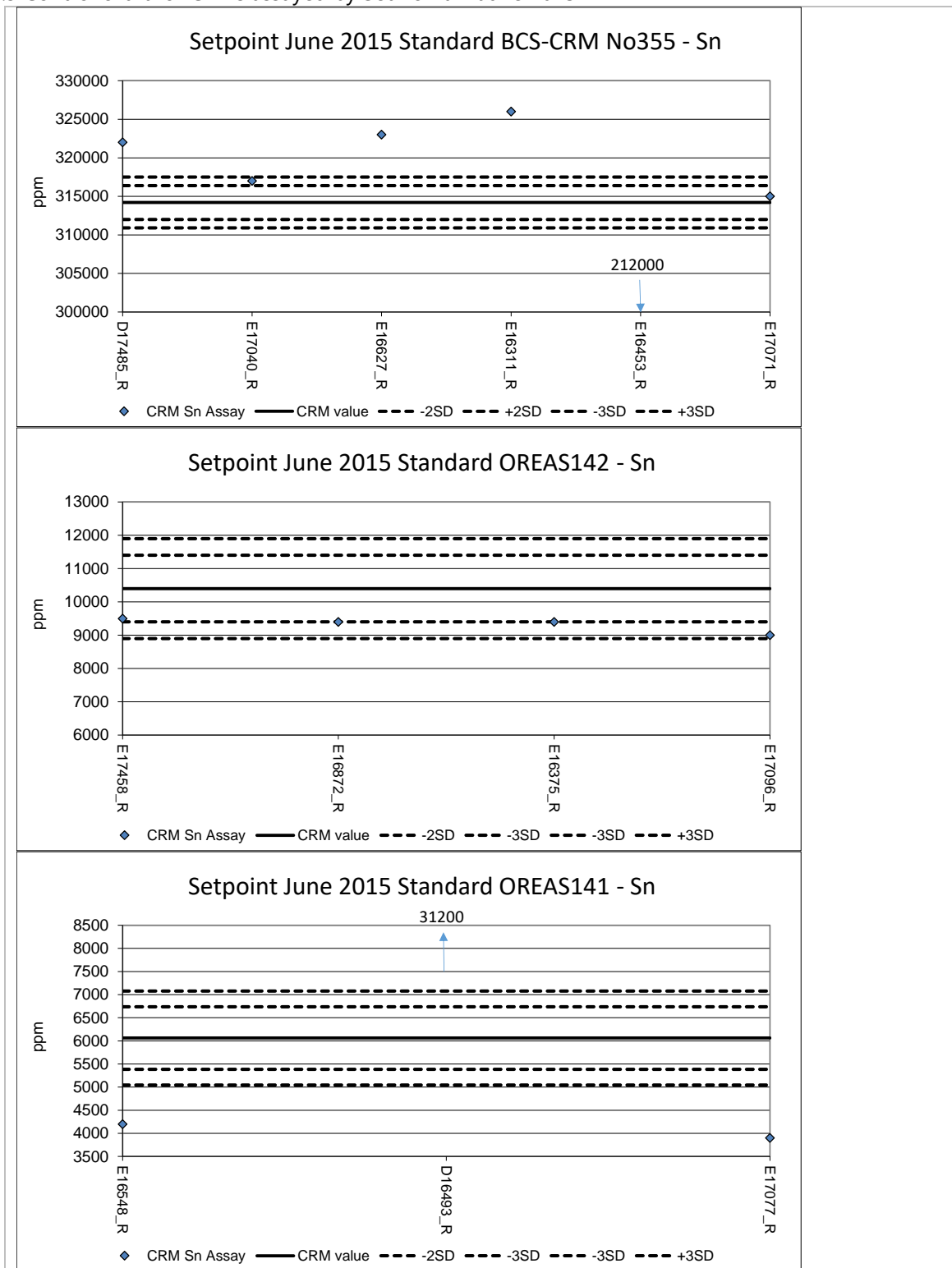

Figure 11.9 Control chart for CRMs assayed by Set Point in June 2015



33 pulp rejects from the 2015 drilling were sent to SGS in 2016 for verification assaying of tin. Nine of the samples were above the upper detection limit of 5 % for XRF at SGS and were assayed using a titration method. The samples assayed by XRF compared well with the ALS assays, however the samples assayed by titration returned lower values than ALS (Table 11.9, Figure 11.10). This is with the exception of one assay that was above the ALS upper detection limit of 60 %, for which SGS returned a value of 68.2 %. Two of the re-assays were of the high grade CRM (BGS-CRM No355). In both cases SGS

returned considerably lower values than the certified mean of the CRM, whereas the ALS assay was consistent with the certified mean value (Table 11.10).

Table 11.9 Mean values and standard deviation in ppm of ALS versus 2016 SGS pulp duplicate assays at Bisie

	Sn % SGS by XRF		Sn % SGS by Titration	
	Mean	Standard Deviation	Mean	Standard Deviation
ALS	1.01	1.36	23.72	14.69
SGS	1.02	1.34	20.75	12.46
% Mean Difference	0.6	1.4	13.3	16.4

Note that the value that was reported at the upper detection limit by ALS was excluded from these statistics

Table 11.10 Results of the BGS-CRM No355 assays for the 2016 confirmation assay program

	D19779 Sn %	D19681 Sn %
ALS	31.70	31.50
SGS	25.30	29.60
Certified Mean	31.42	31.42

Figure 11.10 Scatterplot for ALS versus SGS 2016 assays of 2015 samples - tin pulp duplicate assays. Upper graph shows SGS tin assay by XRF and lower graph by titration

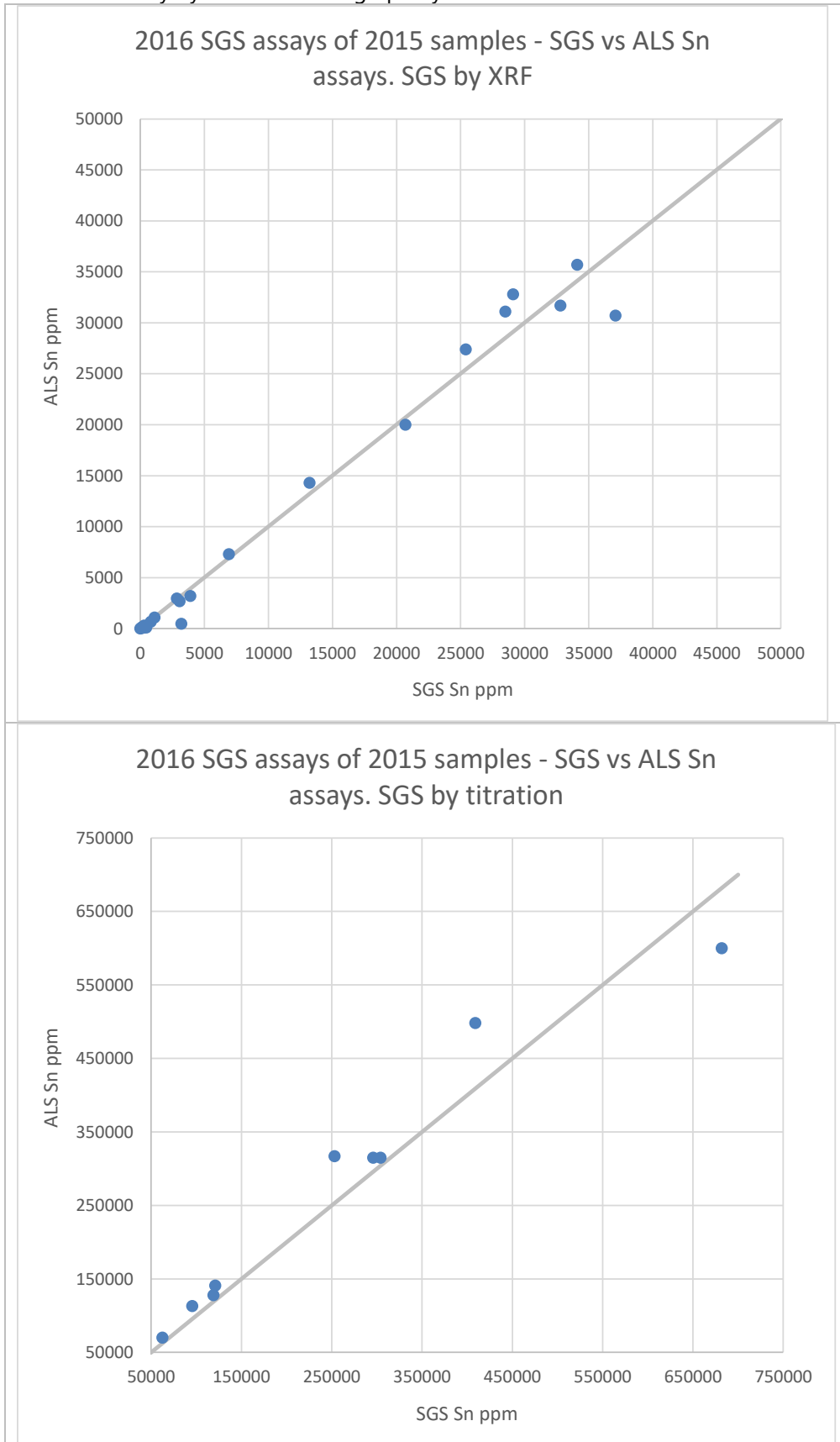

For the 2016 assays, it can be concluded that the ALS assays have been confirmed by SGS for those conducted using XRF by SGS. For those assays performed using titration by SGS (>5 % Sn), the Bisie Tin Project NI 43-101 Technical Report – 23 March 2017

comparison is inconclusive, as the SGS assays of the high grade CRM were considerably lower than the certified mean value.

11.1.6 Re-assaying of pre-2015 samples by ALS

In order to understand any error in the high grade tin assays prior to 2015, a selection of pulp rejects from pre-2015 were re-labelled and sent to ALS for re-assay in 2016. Ninety eight samples across a range of original assay values from 1.5 % to 60 % Sn were selected, this being the grade range in which the over-assaying could occur; the lower grade CRM assays being deemed to be accurate. The intention was to isolate the grade threshold at which a bias occurs and then re-assay all the pulps above that threshold. Included with the pulp rejects were ten CRM samples of the high grade BCS-CRM No355 (31.4 % Sn) and three of the lower grade OREAS 142 (1.04 % Sn).

ALS returned tin grades for BCS-CRM No355 mostly within tolerance with a slight high bias consistent with the post February assays of this CRM by ALS. The assays of OREAS 142 were also found to be accurate (Figure 11.11).

Figure 11.11 Control charts for CRMs assayed by ALS in 2016 for the re-assay program

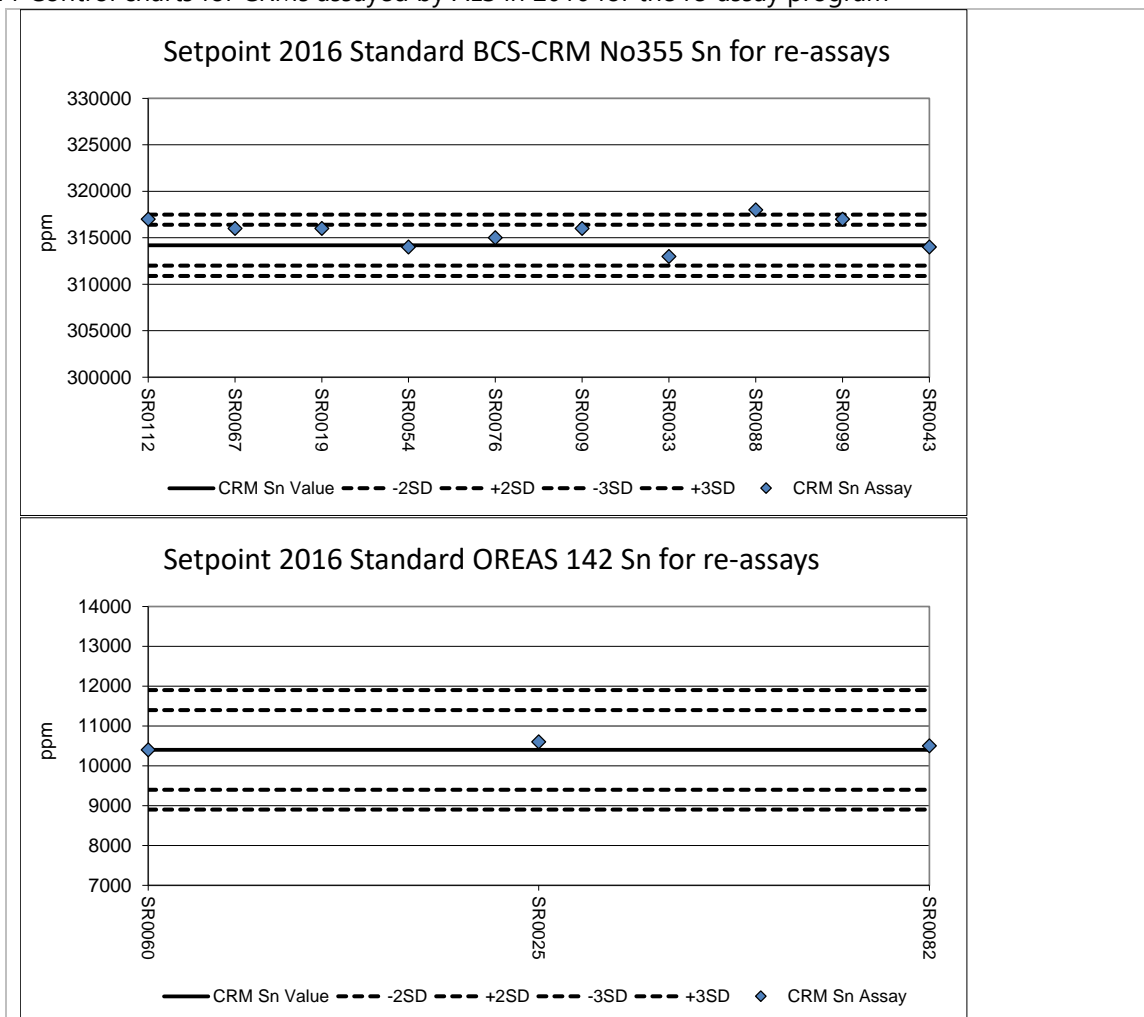

The 2016 assays compared reasonably well with the pre 2015 original assays with the 2016 re-assays returning values on average 5% higher than the original (Figure 11.12). This was not-expected given the results of the CRM analysis completed prior to 2016.

Figure 11.12 Scatterplot for ALS 2016 re-assays versus ALS pre 2015 assays

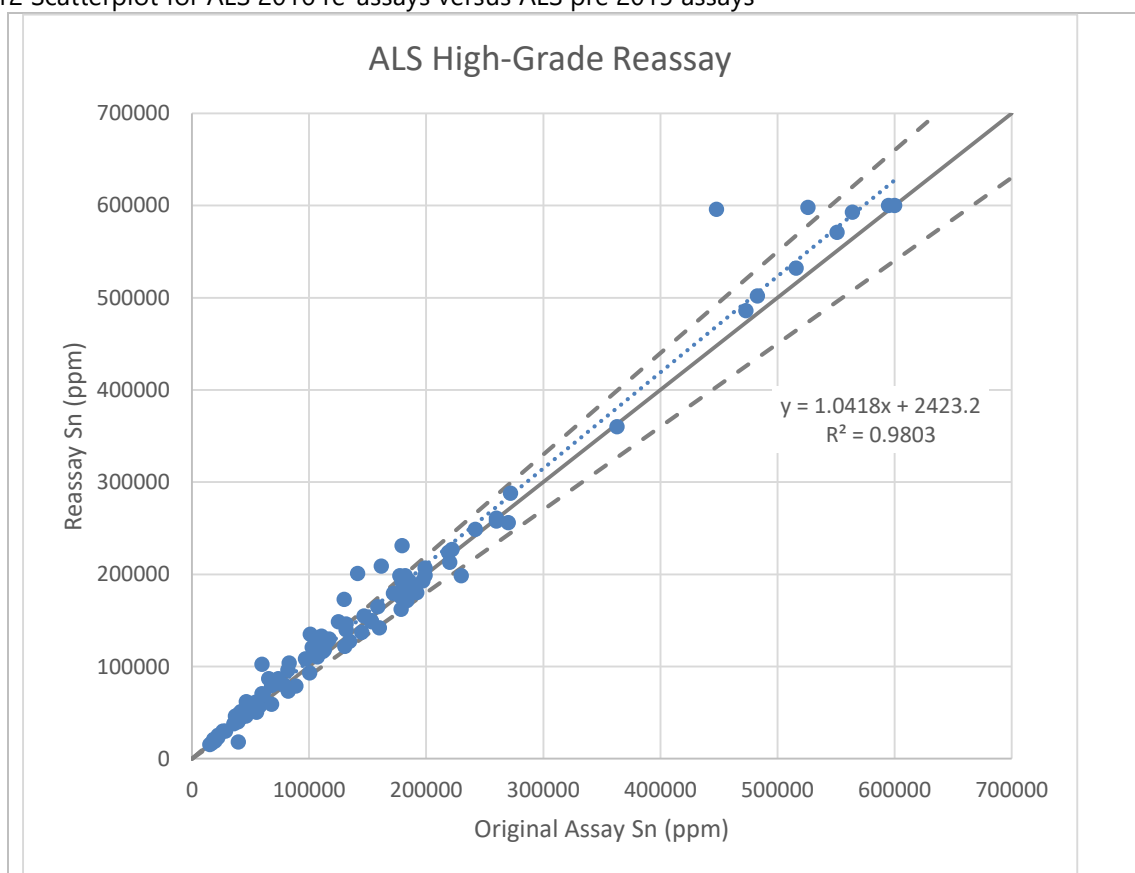

11.2 SUMMARY OF THE EXTERNAL ASSAY QAQC CHECKS

- The field duplicate data indicate that the tin mineralization is nuggety, which is expected in the high grade vein style of mineralization at Bisie.
- The assays of the lower grade CRMs (<1.05 % Sn) by ALS are accurate and precise. However there was evidence that ALS may have over-assayed the high tin grade samples prior to 2015 as shown by the high grade CRM and comparisons with one of the other check laboratories (Set Point). The re-assay program completed in 2016 demonstrated that the pre-2015 assays are of reasonable accuracy, the reason for the higher than expected high grade CRM assays prior to 2015 remaining uncertain.
- The silver assays completed on the Bisie samples are of poor accuracy at grades of less than 1.5 g/t, being biased lower than the CRMs accepted mean values, however given the low grade of silver in the Bisie deposit, the risk to the project is low.
- The copper assays are considered to be of good quality, as shown by the low failure rate for the CRMs and the good repeatability of the ALS assays by SGS.
- The zinc assays are accurate with a slight low bias for zinc indicated by the CRM analysis. The SGS zinc assays were lower than those of ALS.
- Overall the lead analyses were outside of acceptable limits both for the CRM assays and the second laboratory pulp duplicate assays; however given the low grade of lead in the Bisie deposit the risk to the project is low.

In summary, the quality of the assays is reasonable with the exception of the lead and low grade silver assays which should be considered to be of low confidence. No batches of assays were failed on the basis of the QAQC samples.

In the QP's opinion, the assay data can be used for Mineral Resource estimation. The pre-2015 assays can be used without modification as they have been demonstrated to be of reasonable accuracy by the re-assay program.

12 DATA VERIFICATION

The Bisie site was visited by Mr J.C. Witley in July 2013, May 2014 and August 2015. The length of each site visit was three days. During the site visit a selection of cores were inspected, the positions of the drill sites verified and the exploration processes were reviewed. During the first site visit independent check sampling was carried out by the QP.

12.1 INDEPENDENT CHECK SAMPLING

As part of the data verification exercise, ten quarter core samples were taken from two drillholes (BGC018 and BGC024) across a variety of mineralization intensities within the well mineralized zone. The samples were photographed on site and sealed and prepared for dispatch to ALS Chemex (ALS) in Johannesburg. On arrival in Johannesburg, the samples were unpacked, photographed, verified against the photographs taken on site and then sent for assay.

A comparison of the original assays with the independent check sampling assays is shown in Table 12.1 and the tin and copper results are shown as scattergrams in Figure 12.1.

Table 12.1 Check sample assay results

Sample ID	Sn%		Cu%		Ag g/t		Pb ppm		Zn%	
	Original	Check	Original	Check	Original	Check	Original	Check	Original	Check
BGC024_39	2.88	1.79	0.04	0.04	0.5	0.0	8	6	0.06	0.06
BGC024_40	2.01	6.78	0.07	0.08	0.0	0.0	5	15	0.06	0.06
BGC024_41	3.20	3.12	0.16	0.14	1.2	0.0	12	16	0.07	0.07
BGC024_42	1.80	1.95	0.14	0.14	1.3	0.0	15	13	0.08	0.08
BGC024_43	11.00	15.45	0.14	0.17	1.4	0.0	22	26	0.07	0.07
BGC018_45	1.04	1.11	0.59	0.58	5.0	5.1	35	38	0.63	0.73
BGC018_46	38.80	29.00	0.49	0.51	4.2	4.4	32	47	0.07	0.10
BGC018_47	0.35	0.35	0.59	0.61	4.2	4.1	22	31	0.10	0.10
BGC018_48	12.50	1.39	0.45	0.61	3.7	4.8	43	45	0.22	0.13
BGC018_49	1.68	4.49	0.79	0.71	6.4	5.7	45	43	0.09	0.08
Mean	7.53	6.54	0.35	0.36	2.8	2.4	24	28	0.14	0.15

Figure 12.1 Scattergrams of tin and copper check sample assay results

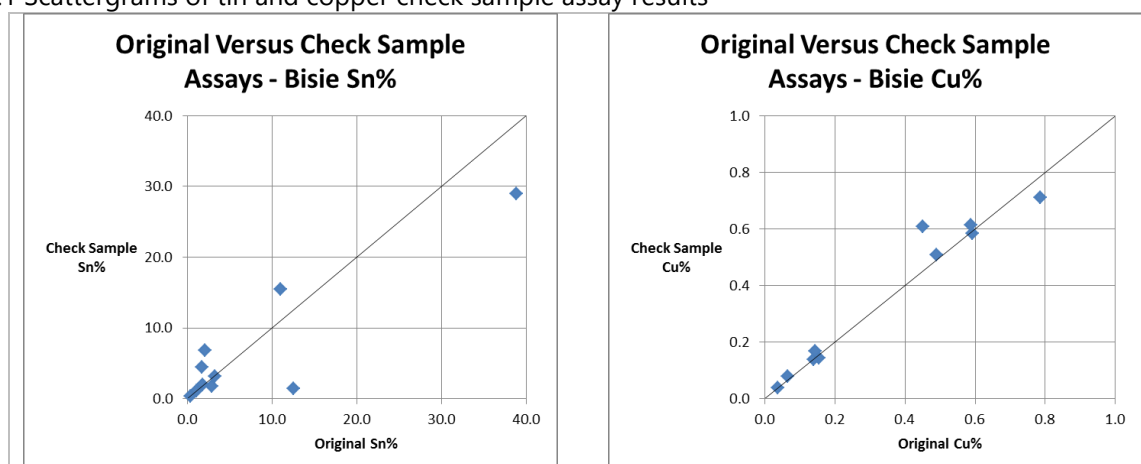

The check assays confirmed the presence of high grade tin, although the individual sample assays did not compare well for the high grade tin samples. Five of the samples were re-submitted with a new sample ID and re-assayed for tin (Table 12.2). The results compared reasonably well with the original check sample results. The difference between the check sample and original sample is likely to be a result of the nuggety nature of the high grade vein mineralization, amplified by the small check sample size (quarter NQ core). No particular bias was noted for the tin assays with the high grade check sample assays being either lower or higher than the original.

Table 12.2 Check sample assay results – re-assays

Sample ID	Sn %	
	Original	Re-assay
BGC024_39	1.79	1.79
BGC024_40	6.78	6.14
BGC024_43	15.45	13.85
BGC018_46	29.00	29.50
BGC018_48	1.39	1.44
BGC018_49	4.49	4.37
Mean	9.82	9.52

No verification assays have been taken since the July 2013 visit, the presence of high grade tin in cassiterite having been confirmed in 2013.

12.2 VISUAL VERIFICATION

The tin mineralization at Bisie is clearly visible in the cores, occurring as coarse grained cassiterite veins and finer disseminations. Most of the core observations confirmed the magnitude of the assayed grades within reasonable limits. A number of tin grades reported were significantly higher or lower than the observations in the remaining half core. This was considered a result of the irregular nuggety nature of the high grade tin mineralization. Cores were observed from a selection of drillholes, which represent a range of mineralization intensities at Bisie (Table 12.3). The second

site visit focussed on examining short range variability in the closely spaced metallurgical sample holes and the third site visit focussed on the extension drilling to the north at depth and the shallow area to the south. Comparisons were made between the observations and the assays received in order to verify the mineralization.

Table 12.3 Drillhole cores for which mineralization was visually verified

July 2013	May 2014	August 2015
BGC006	METBGC010	BGC077
BGC007	METBGC017	BGC086
BGC016	METBGC018	BGC090
BGC017	METBGC020	BGC099
BGC018	METBGC022	BGC104
BGC020	METBGC027	BGC109
BGH001	BGC044	BGC131
BGH006	BGC045	BGH014
BHH007A	BGC046	BGH015
	BGC047	BGH016

12.3 VERIFICATION OF DRILLHOLE COLLARS

Bisie was first visited during the later stages of the Phase 2 drilling program in July 2013, which was aimed at initial Mineral Resource definition. Eleven of the drillhole collars were photographed and the locations verified against the surveyed coordinates by using a hand-held GPS. In May 2014, a number of the drillhole sites were visited including those from which the metallurgical samples were drilled. In August 2015, eleven of the drillhole collar positions were verified using hand-held GPS. All of the hand-held GPS measurements compared within reasonable limits to the final survey.

12.4 SUMMARY OF THE DATA VERIFICATION

- Independent check sampling by the QP confirmed the high tin grade samples characteristic of the Bisie mineralization.
- The mineralization shown by the tin assays was visually confirmed by the QP for a representative selection of drillhole cores.
- The locations of the drillholes were verified within reasonable limits by the checks performed.

13 MINERAL PROCESSING AND METALLURGICAL TESTING

13.1 BACKGROUND

The test work carried out in previous phases of the project by Maelgwyn Mineral Services (MMS) and others was used as a basis for the Updated Feasibility Study and Control Budget Estimate. No new samples were made available, however residual samples from the previous phase was made available for additional testwork. The samples had been retained by MMS at their laboratory in Johannesburg.

13.2 SAMPLE SELECTION

The original bulk sample was constituted from half and three-quarter PQ size (85mm) core sourced from 27 drilled holes at Mpama North. The mass of the combined sample was approximately 7 643 kg and was considered representative of the material which would be accessed during the initial years of mining.

Several samples made available to this phase of study included the following:

- Approximately 400 kg naturally arising -1mm material
- Approximately 17 kg -10 mm +1mm DMS feed material
- Approximately 19 kg -10 mm +1mm DMS sinks material
- Approximately 13 kg -10 mm ROM Material

13.3 REVIEW OF FEASIBILITY STUDY METALLURGICAL TEST WORK

Mineralogy and metallurgical test work was carried out in the last phase of work and was successful in identifying a potential processing route which could produce smeltable grade concentrate with acceptable levels of contaminants.

13.3.1 Mineralogy

The test work identified Cassiterite as the only tin-hosting phase and that it was coarse grained. The majority of associated contaminants were identified as silicates (54%) of which 37% were chlorites. Additionally iron-oxide/hydroxides, ilmenite and rutile were present with further minor associations with sulphides, carbonates and phosphates identified. It was concluded that gravity and flotation processes would be the likely processing route to be followed due to the liberation effects and the grain size observed.

13.3.2 Metallurgical

Gravity pre-concentration of the -10mm +1mm stream was undertaken followed by grinding, spirals, grinding, sulphide flotation and oxide flotation to produce a high grade concentrate. Additionally, liberation grind test work was undertaken to identify the preferred grind sizes for each stage of the process.

The naturally arising -1mm material was concentrated through spirals, however further flotation and gravity test work on this stream was unsuccessful so only a low grade spiral concentrate could be produced.

13.4 UPDATED FEASIBILITY STUDY AND CONTROL BUDGET ESTIMATE METALLURGICAL TEST WORK

Economical assessments of the potential to sell the low grade concentrate produced from the naturally arising -1mm stream were not favourable, so further test work was undertaken with Mintek with the aim of producing a single high grade concentrate from the process, along with further potential optimisations.

13.4.1 Mineralogy

Mineralogy test work confirmed previous results surrounding the main contaminants present in the process. It further expanded on the liberation characteristics of several key streams within the process and suggested potential routes for further optimisation. In summary, a stage wise size reduction followed by a gravity concentration step will produce high grade concentrates at each level of grind, with the majority of the liberated tin losses being incurred at each stage to the ultrafine fraction (-38µm). This suggests that that further work on recoveries in this fine size range would benefit the project in future optimisations.

13.4.2 Metallurgical

The limited sample masses available for test work required that a lab scale, rather than a pilot or commercial scale test work be undertaken. Simplistically, two arms of test work were undertaken with the DMS sinks material (HG) and the naturally arising -1mm material (LG). The test work indicated that tin recoveries in excess of 80% at a grade of above 60% tin was possible through almost exclusively a gravity concentration process with flotation used for contamination removal only. The final processing flow sheet included:

- The split at 1mm was maintained, with the +1mm material considered the HG circuit and the -1mm material considered the LG circuit.
- The HG sample available was already a DMS sinks concentrate. This was milled prior to the shaking table test work, designed to simulate a spirals/ shaking table arrangement, followed by further milling and sulphide rejection flotation to produce a >60% tin concentrate. All of the test work was carried out at Mintek and utilised a pilot scale shaking table and lab scale flotation cells.
- The LG sample was subjected to the shaking table test work, designed to simulate a spirals/ shaking table arrangement, followed by milling, a further stage of shaking tables and sulphide rejection flotation to produce a final concentrate of >60% tin. All of the test work was carried out at Mintek and utilised a pilot scale shaking table and lab scale flotation cells.
- Sulphides removal by flotation was in excess of 90% effective, with the final quantities of contaminants in the concentrate within range to ensure no excessive smelter penalties. The flotation cells used were forced induction, conventional, lab scale units which are commonly scaled up and used within industry.

Examples of the additional equipment used for the latest test work campaign are shown in the figures below.

Figure 13.1 MINTEK Pilot Scale Shaking Table



Source DRA

Figure 13.2 MINTEK bench scale flotation cell



Source DRA

14 MINERAL RESOURCE ESTIMATES

On behalf of Alphamin, MSA has completed a Mineral Resource estimate for the Mpama North prospect of the Bisie Project.

To the best of the QP's knowledge there are currently no title, legal, taxation, marketing, permitting, socio-economic or other relevant issues that may materially affect the Mineral Resource described in this Technical Report, aside from those already mentioned in Item 4 of this Report.

The Mineral Resources presented herein, with an effective date of 09 May 2016, represent an update to the previous Mineral Resource estimate with an effective date of 15 October 2015. The Mineral Resource estimate incorporates drilling data from holes completed by Alphamin from July 2012 until November 2015 inclusive, which in the QP's opinion were collected in accordance with The Canadian Institute of Mining, Metallurgy and Petroleum (CIM) "Exploration Best Practices Guidelines", 2000.

The Mineral Resource was estimated using the 2003 CIM "Best Practice Guidelines for Estimation of Mineral Resources and Mineral Reserves" and classified in accordance with the "2014 CIM Definition Standards". It should be noted that Mineral Resources are not Mineral Reserves and do not have demonstrated economic viability.

The Mineral Resource estimate was conducted using Datamine Studio 3 software, together with Microsoft Excel, JMP and Snowden Supervisor for data analysis. The Mineral Resource estimation was completed by Mr Jeremy Witley, the QP for the Mineral Resource.

14.1 MINERAL RESOURCE ESTIMATION DATABASE

The database used for the Mineral Resource estimate consists of:

- information from diamond drillholes,
- collar surveys,
- down-the-hole-surveys,
- sampling and assay data,
- specific gravity measurements,
- geology logs,
- a digital terrain model (DTM) based on a high resolution LIDAR survey.

The principal sources of information used for the estimate include raw data generated during the course of the exploration drilling program conducted by Alphamin between July 2012 and November 2015 inclusive. The currently planned phases of drilling are complete. The Mineral Resource estimate was based on tin, copper, lead, zinc and silver assays and density measurements obtained from the cores of 122 NQ size diamond drillholes. In addition to the exploration drillholes the split cores from 21 closely spaced PQ size holes were used in the estimate. These holes were drilled in three clusters for the purpose of obtaining a metallurgical test sample. The drillholes were angled downwards at between 60° and 75° to the west and planned to intersect the mineralized zones at a spacing of between approximately 25 m and 100 m on the plane of mineralization.

The cut-off date for inclusion of data into this estimate is 06 April 2016 at which time there were no outstanding drilling data of significance.

14.2 EXPLORATORY ANALYSIS OF THE RAW DATA

The dataset examined consisted of sampling and logging data from diamond drillholes (DD). The following attributes are of direct relevance to the estimate:

- Tin (Sn), silver (Ag), copper (Cu), zinc (Zn), lead (Pb), sulphur (S) and arsenic (As) assays in parts per million (the tin, copper, zinc, lead and sulphur data were converted to per cent for the Mineral Resource estimation),
- Specific Gravity (SG) measurements,
- Lithological Codes.

The high grade mineralization occurs within a persistent zone of intense chloritisation termed amphibolite by the Alphamin geologists. Less continuous and narrower zones of mineralization occur in places above and below the Main Vein zone, thus three zones were defined; the Main Vein, the Footwall Vein and the Hangingwall Vein zones.

Visual inspection of the data showed that the well mineralized intersections occur within drillholes drilled between 25 m and 50 m apart along east-west fence lines spaced approximately 50 m apart over a strike length of approximately 600 m, with some infill drilling at 25 m line spacing. Two holes, BGC008 and BGC009, were drilled 150 m and 280 m to the north respectively, with both intersecting the prospective chlorite schist zone, however they were not significantly mineralized. The best intersection in BGC008 was 0.76% Sn over 0.4 m and in BGC009 0.09 % Sn over 1 m. A number of intersections have been drilled to the south of the March 2015 Mineral Resource and significant mineralization has been intersected. Examination of the drillhole data in section revealed that in the down dip areas a number of below threshold grade intersections occur that have constrained the down dip extent of most of the mineralized zone. However the mineralization clearly plunges to the north and is open down-plunge to the north.

Several of the drillholes, BGC013, 014, 015, 016 and 032 are affected by artisanal mining activity as evidenced by cavities and cored wooden mine supports. Each one of the affected holes is the uppermost hole in the respective fence line along which it was drilled. The data from these holes were used to inform the mineralization model extents, but were not used for grade estimation as it was assumed that much of the high grade tin mineralization would have been removed by the artisanal miners and that the remaining mineralization is not representative of the in-situ mineralization.

A summary of the drillhole data used for the Mineral Resource estimate is provided in Appendix 3.

14.2.1 Validation of the data

The validation process consisted of:

- examining the sample assay, collar survey, down-hole survey and geology data to ensure that the data were complete for all of the drillholes,
- examining the de-surveyed data in three dimensions to check for spatial errors,
- examination of the assay and density data in order to ascertain whether they were within expected ranges,
- checks for "From-To" errors, to ensure that the sample data did not overlap one another or that there were no unexplained gaps between samples.

The data validation exercise revealed the following:

- As at the effective date of this report data are available for BGC001 to BGC171.
- A number of the holes drilled were for geotechnical or sterilisation drilling to support other aspects of the ongoing mining study, many of them being outside of the Mineral Resource area.
- SGs were measured on pieces of the sample rather than for the entire sample and, given the variable mineralization at Bisie, will not always represent the density of the entire sample. As a result, individual SG values measured in this way are considered unreliable due to the in-heterogeneous nature of the tin mineralization within the samples. SGs were later measured at the laboratory using a gas pycnometer, however SGs were not determined for all samples in all holes.
- There are no unresolved errors relating to missing intervals and overlaps in the drillhole logging data.
- No default values, except for detection limit data, were found. Fifteen tin grades of 60 %, 64 arsenic grades of 10,000 ppm and 141 sulphur values of 10% occur in the assay database, which is the upper detection limit used by ALS for these elements.
- Examination of the drillhole data in three dimensions shows that the collars of the drillholes surveyed by DGPS plot in their expected positions. However, five of the holes (BGC162 and BGC168 to BGC171) had not yet been surveyed by DGPS and their elevations were derived from the LIDAR survey topographic model.
- 2,698 laboratory SG measurements exist in the database for Mpama North. None of the values fell outside of expected ranges for the rock types and mineralization at Bisie.
- Extreme assays were checked. The highest silver assay in the Bisie dataset is 775 g/t followed by 113 g/t and the next highest value is 109 g/t. The 775 g/t value was removed from the database for estimation.

14.2.2 Statistics of the Sample Data

A total of 8,293 assayed samples occur in the Mpama North database of which 8,257 were assayed for tin.

A histogram and cumulative frequency plot of the sample lengths are presented in Figure 14.1. 98 % of the sample lengths are 1.0 m or less. No relationship between sample length and tin grade is apparent.

Figure 14.1 Histogram and cumulative frequency plot of the sample length data

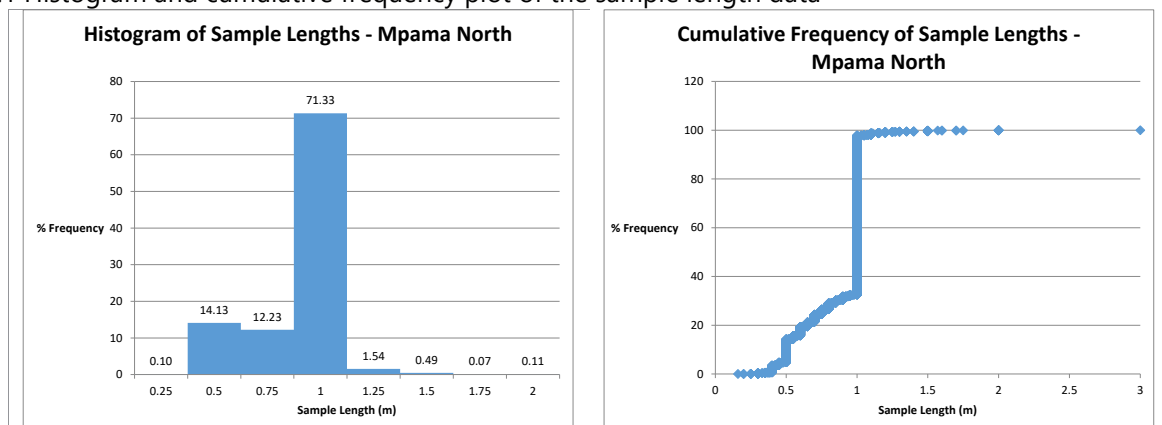

14.2.3 Statistics of the Assay Data

14.2.3.1 Univariate Analysis

A summary of the sample assay and SG data statistics in the raw data at Mpama North is shown in Table 14.1.

Table 14.1 Summary of the raw validated sample data at Mpama North

Variable	Number of Assays	Mean Value	Minimum Value	Maximum Value
Sn ppm	8,257	15,337	<5	600,000*
Ag g/t	8,293	1.55	<0.5	113
Cu ppm	8,293	1,516	<1	103,500
Zn ppm	8,293	1,042	<2	121,000
Pb ppm	8,293	143	<2	51,500
S%	8,293	1.11	<0.01	10*
As ppm	8,293	265	<5	10,000*
SG	2,698	3.21	2.27	6.33

*Note that the upper limit of detection for Sn value assayed was 60 %, As 10,000 ppm and S 10%

The maximum assay value reported for tin is 600,000 ppm, arsenic 10,000 ppm and sulphur 10 %. These are the maximum reported values for the assay methods used. Over-limit assays were not performed for arsenic and sulphur. There are 64 arsenic values, 15 tin values and 141 sulphur values reported on the upper assay limit. The impact on the tin estimate will be negligible although a slight underestimation of arsenic and sulphur will occur.

The tin sample data was examined in order to understand the general grade distribution and to determine thresholds that may be used to define mineralized envelopes. The data distribution is mixed containing several grade populations. A break in the log cumulative frequency plot was noted at approximately 0.35 % Sn. Observation of the drillhole data in section revealed that approximately 0.35 % Sn is also a practical grade threshold in which to constrain the mineralization in a three dimensional model. A distinct high grade population was noted that should be considered in the grade estimation.

Figure 14.2 Log cumulative frequency plot of the sample Sn grade data

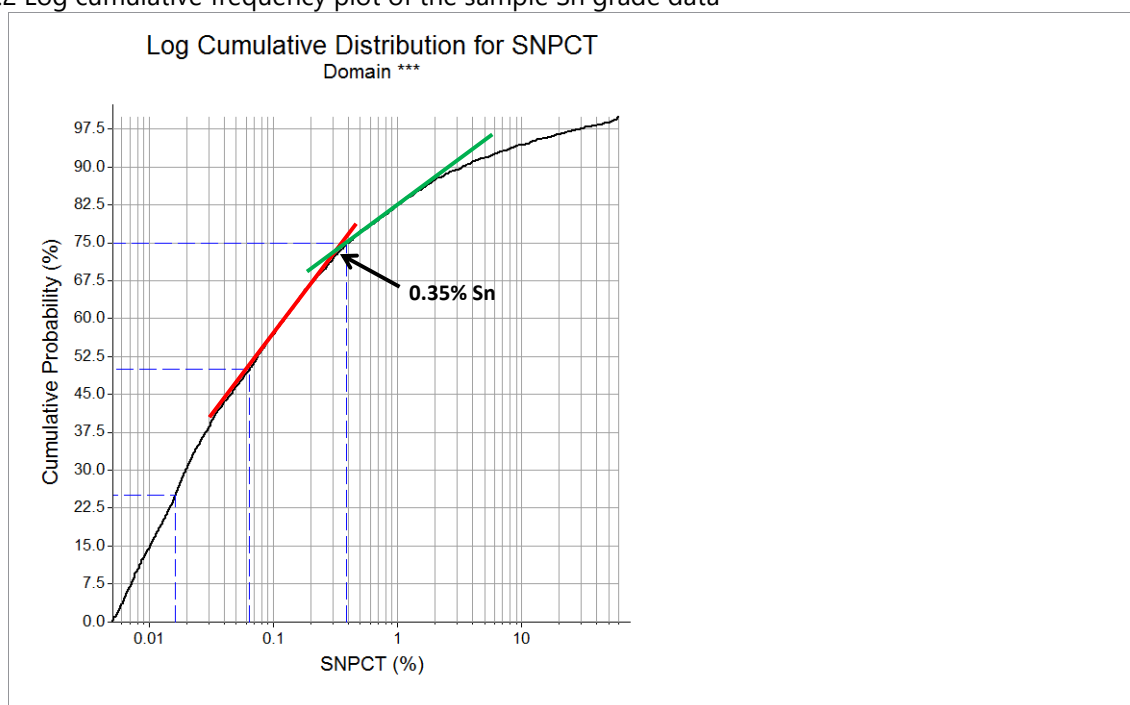

14.2.3.2 Bivariate Analysis

Scatterplots were made that compare the grades of each variable with one another in order to understand any relationships that may exist in the data that should be preserved in the Mineral Resource estimate. A linear relationship between tin grade and SG is observed with the grade of tin increasing with density. Very weak relationships are observed between copper and zinc and copper and sulphur.

14.2.3.3 Relationship between tin grade and specific gravity

It is expected that there will be a strong relationship between tin grade and specific gravity as the tin bearing mineral at the Project is cassiterite, which has a high specific gravity (approximately 7.0). This relationship can be used to estimate the SG based on the tin grade.

Not all samples were measured for SG and so the SGs were assigned to those samples that were not measured. It is important to assign SG to samples as SG is used to composite the sample data to equal lengths using length and density weighting during the estimation process. For the un-mineralized zones, a constant value for each lithology, calculated using the mean value of the un-mineralized zones, was applied as shown in Table 14.2.

Table 14.2 Default density value applied for each rock type in the waste zones at Bisie.

Rock Type	SG
Chlorite Schist (AMPH)	3.16
Chlorite mica schist (ASCH)	3.06
Core loss (CL)	3.06
Mica Schist (MSCH)	2.98
Quartz Vein	2.78
Shear Zone	2.95
Fault Zone	3.06

SGs for the mineralized samples were assigned to samples without SG measurements using a polynomial regression on the average SG for a number of tin grade bins as shown in Figure 14.3. The use of a regression is not ideal, however the regression is robust and little risk to the Mineral Resource estimate will be incurred.

Figure 14.3 Regression Analysis for SG versus Sn grade

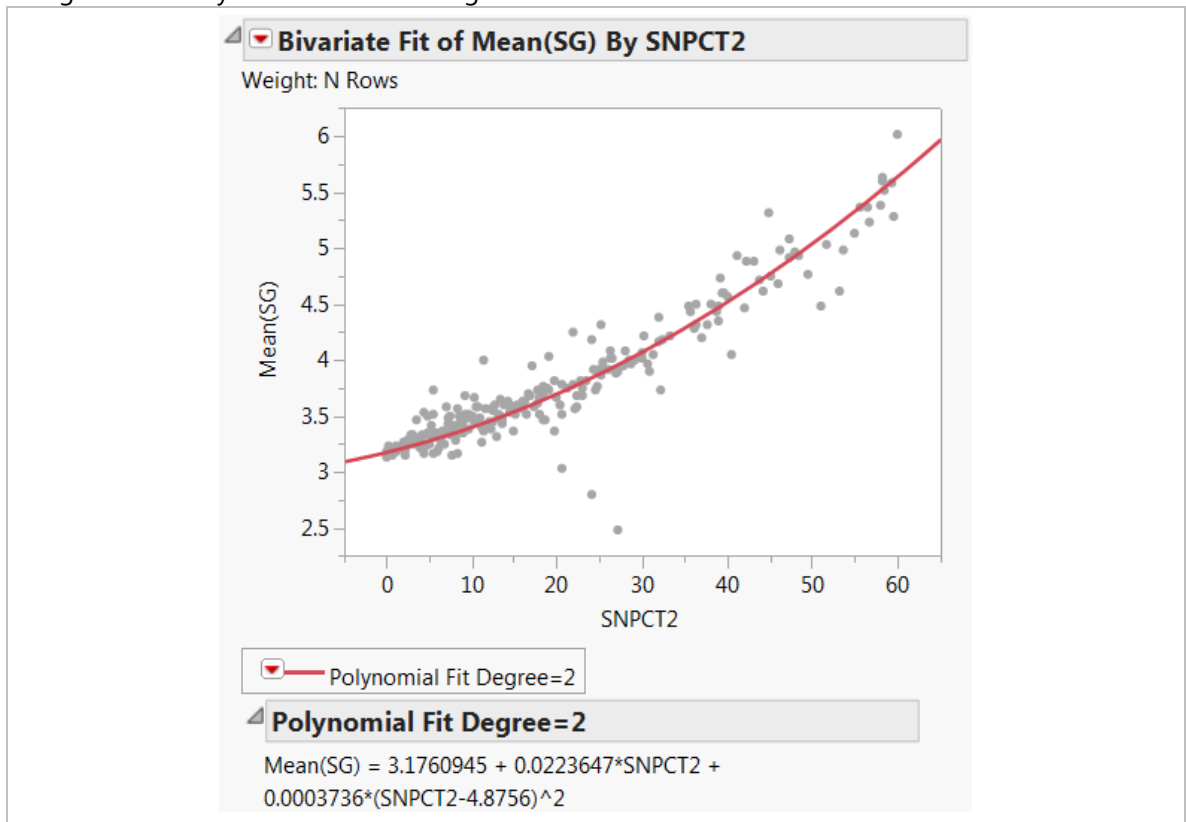

14.2.3.4 Comparison between Laboratory Gas Pycnometer and On-Site Wet-Dry Determinations

The SG measurements were obtained by laboratory gas pycnometer. This differs from the generally accepted method of weight in air versus weight in water (the Archimedes principle) in that it does not take the porosity of the samples into account and therefore may over-estimate the density.

SG was routinely determined on site using weight in air versus weight in water. These were made on 15 cm lengths of core, rather than the entire sample, and, due to the heterogeneity of the cassiterite mineralization, were not considered representative of the SG of the entire sample and so were not

used in estimation. A comparison was made between the samples of drillholes that had both gas pycnometer and wet-dry SG measurements. A quantile-quantile (QQ) plot is shown in Figure 14.4, which demonstrates that the gas pycnometer method tends to over-estimate SG compared to the Archimedes method for values less than the mean value and under-estimates values for the denser samples. Overall the two methods compare well, with the average pycnometer SG being 3.38 and the average wet –dry SG being 3.39. Therefore it is considered that use of the gas pycnometer SGs for density determination is a reasonable approach.

Figure 14.4 QQ plot of gas pycnometer SG versus wet-dry method

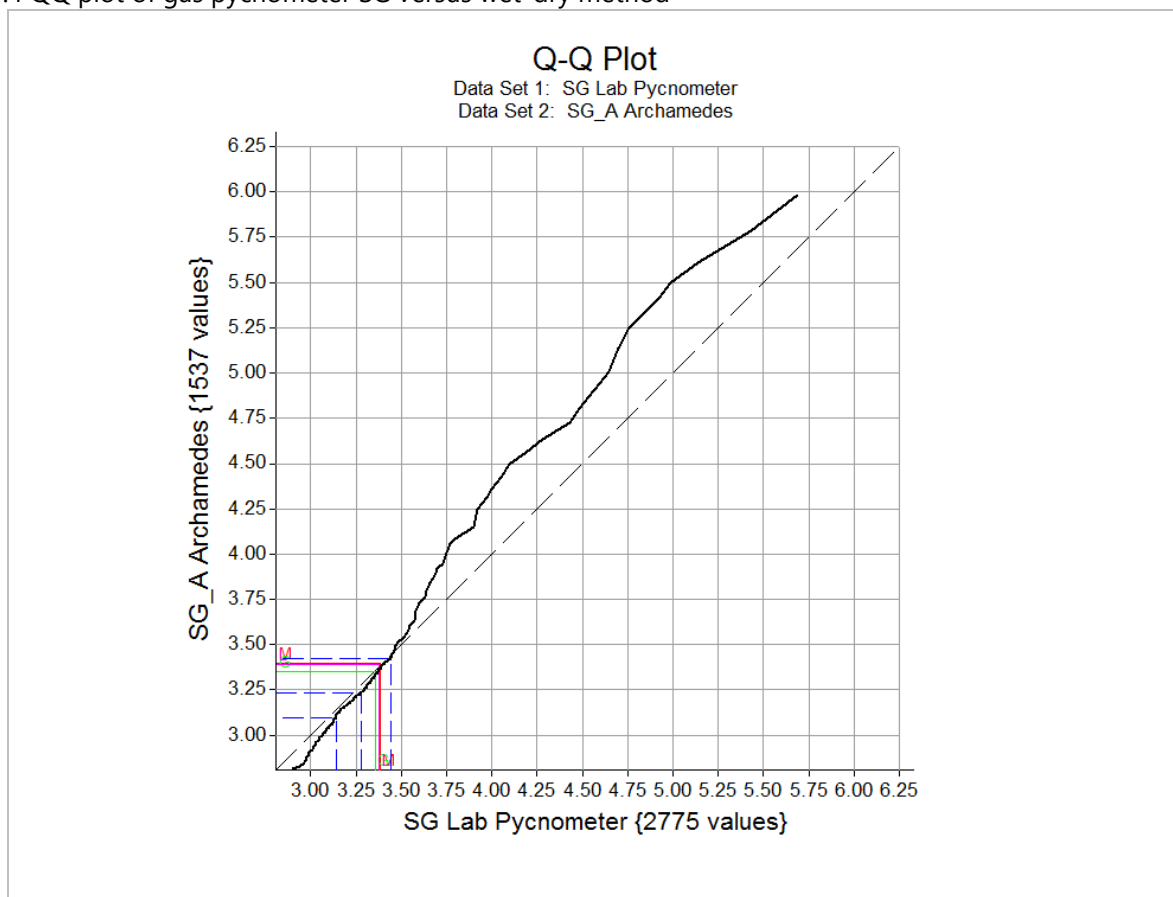

14.2.4 Summary of the Exploratory Analysis of the Raw Dataset

- The database is robust,
- most sample lengths are 1 m or less,
- the host rock to the mineralization is mainly chlorite schist (locally termed amphibolite),
- parts of the uppermost portion of the deposit have been removed by artisanal miners and several of the shallow drillholes are unrepresentative, having drilled through the workings,
- a threshold of 0.35 % tin is considered suitable to model zones of significant tin mineralization,
- a high tin grade population occurs,
- there is a strong relationship between tin grade and SG, which was used to assign density to the samples that were not measured for SG,

- laboratory gas pycnometer SGs compare well with wet-dry determined SGs and use of the gas pycnometer SGs for density determination is considered a reasonable approach,
- the Mpama North mineralized zone is constrained by drilling down dip, although potential to extend the mineralized zone exists down-plunge northwards and along strike to the south.

14.3 GEOLOGICAL MODELLING

14.3.1 Topography

Alphamin conducted a LIDAR survey in the second quarter of 2015 in order to provide for an accurate model of the topography. The processed data was provided as points on a 2 m by 2 m grid and a digital terrain model (DTM) was created from the point data. A LIDAR survey is considered one of the most accurate remote methods available to survey topography.

Figure 14.5 Isometric View of the DTM created from the LIDAR survey data - view is approximately to the north

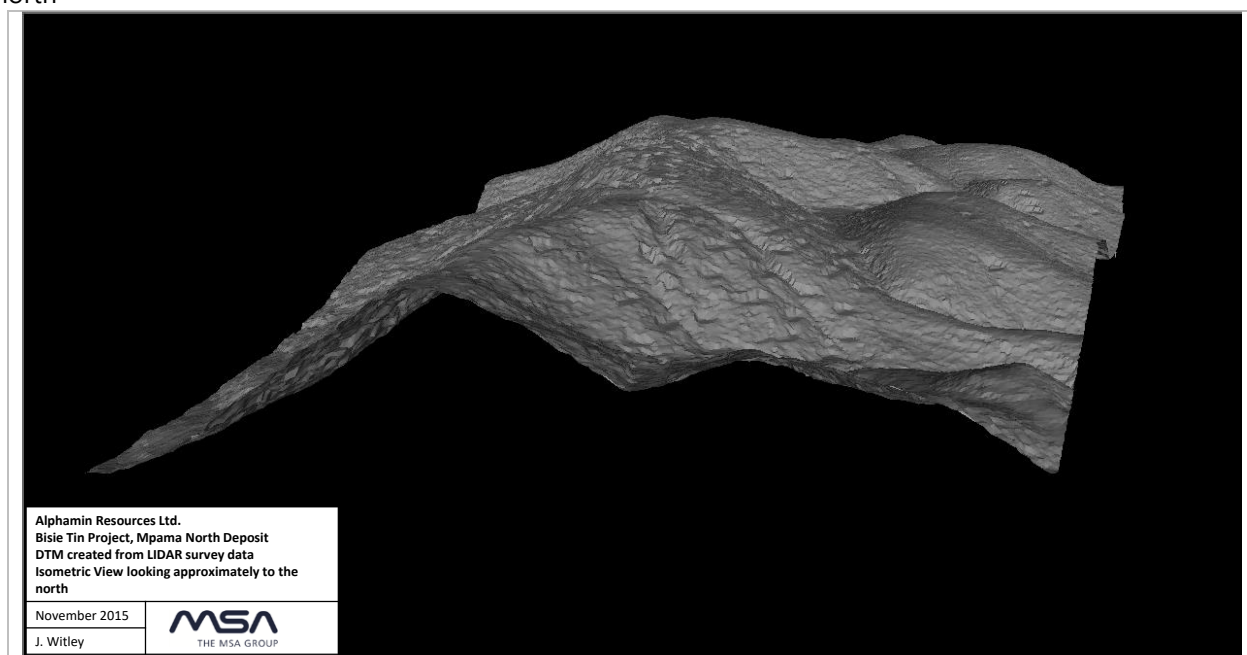

Source MSA

14.3.2 Mineralized Zones

The drillhole data were examined for the occurrence of cassiterite mineralization relative to the geological logging. Consistent with the October 2015 estimate, three zones of mineralization were modelled (Figure 14.6):

- The Main Vein mineralization consisting of a number of uncorrelated cassiterite veins within pervasively chloritised schist (logged as amphibolite). This zone generally occurs over thicknesses of between 2 m and 22 m with an average thickness of approximately 9 m. This zone is generally the highest grade and most consistent.
- Hangingwall Vein (HW Vein) mineralization occurring within partly chloritised schist (logged as amphibolite schist) and micaceous schist between 1 m and 20 m above the Main Vein. This zone of mineralization is generally between 0.5 m and 4 m wide and occurs in

the northern area of the deposit although it appears to taper out northwards. The middling between the Hanging Wall Vein and the Main Vein decreases in areas and it is possible that this vein merges into the Main Vein in the some parts of the deposit.

- Footwall Vein (FW Vein) mineralization, occurring within the micaceous schist and amphibolite schist between 1 m and 10 m below the Main Vein. This zone is restricted to the southern areas, is very narrow (<50 cm) and high grade in its most northern occurrences. Towards the south it thickens to approximately 6 m. It is possible that this vein merges into the Main Vein in the some parts of the deposit.

All three zones have been modelled in a small area of the deposit, which coincides with an area of bonanza-style mineralization where the metallurgical sample holes were drilled. It should be noted that the deposit is open down-plunge and opportunities to increase the size of the deposit exist.

A northwest to southeast striking sub-vertical fault has been modelled in the south of the deposit. The interpreted fault has a down-throw of approximately 15 m to the south. Several mineralized intersections have been drilled to the south of this fault, however the structure of the deposit is uncertain in this area. A 20 m strike by 85 m dip slab of mineralization (the S1 block) has been modelled on the basis of three drillhole intersections, however several mineralized intersections in the area remain unresolved.

A sub-vertical fault was previously modelled in the north of the deposit striking from southwest to northeast. This was modelled on the basis of only two drillhole intersections and therefore the structure was uncertain. Two drillholes (BGC044 and BGC127) within the main area of mineralization were not used when creating the October 2015 model. The positions of the mineralization were not consistent with the surrounding drillholes and they were discarded from the estimate until the cause for the discrepancy was resolved. Inclusion of these holes and the new drilling data has led to a revised structural interpretation comprising two faults that strike northwards sub-parallel with the plunge of the Main Vein mineralization. Although the exact nature of these faults is uncertain there is significant displacement (over 10 m) associated with them. Low angle faulting sub-parallel to the mineralized unit has been described previously and it is possible that the displacements modelled relate to this type of structure.

It should be noted that although the mineralization has been modelled as steeply dipping slabs, the mineralization within the individual zones occurs in the form of irregular high grade veins of botryoidal cassiterite several tens of centimetres thick and lesser amounts in blebs and vein fragments irregularly disseminated in the schist. The brecciated nature of the tin veins may be an indication that the slabs are broken in places and additional faults that are not resolvable on the scale of the drilling may occur.

Grade shells for the mineralized zones were created using a 0.35 % Sn threshold. Points were created for the hangingwall and footwall positions of each grade zone and these were linked together in a series of strings that were used to create the grade shell wireframes (Figure 14.6).

A "mined out zone" was created that encloses the drillholes that have been identified as having intersected artisanal workings (Figure 14.6). It should be noted that although artisanal mining has taken place, the tin mineralization was not completely removed and potential for remaining tin mineralization exists within the "mined out zone". The mined out zone extends from surface to approximately 50 m below surface.

Figure 14.6 Isometric views of the April 2016 model, view to east (top) and west (bottom)

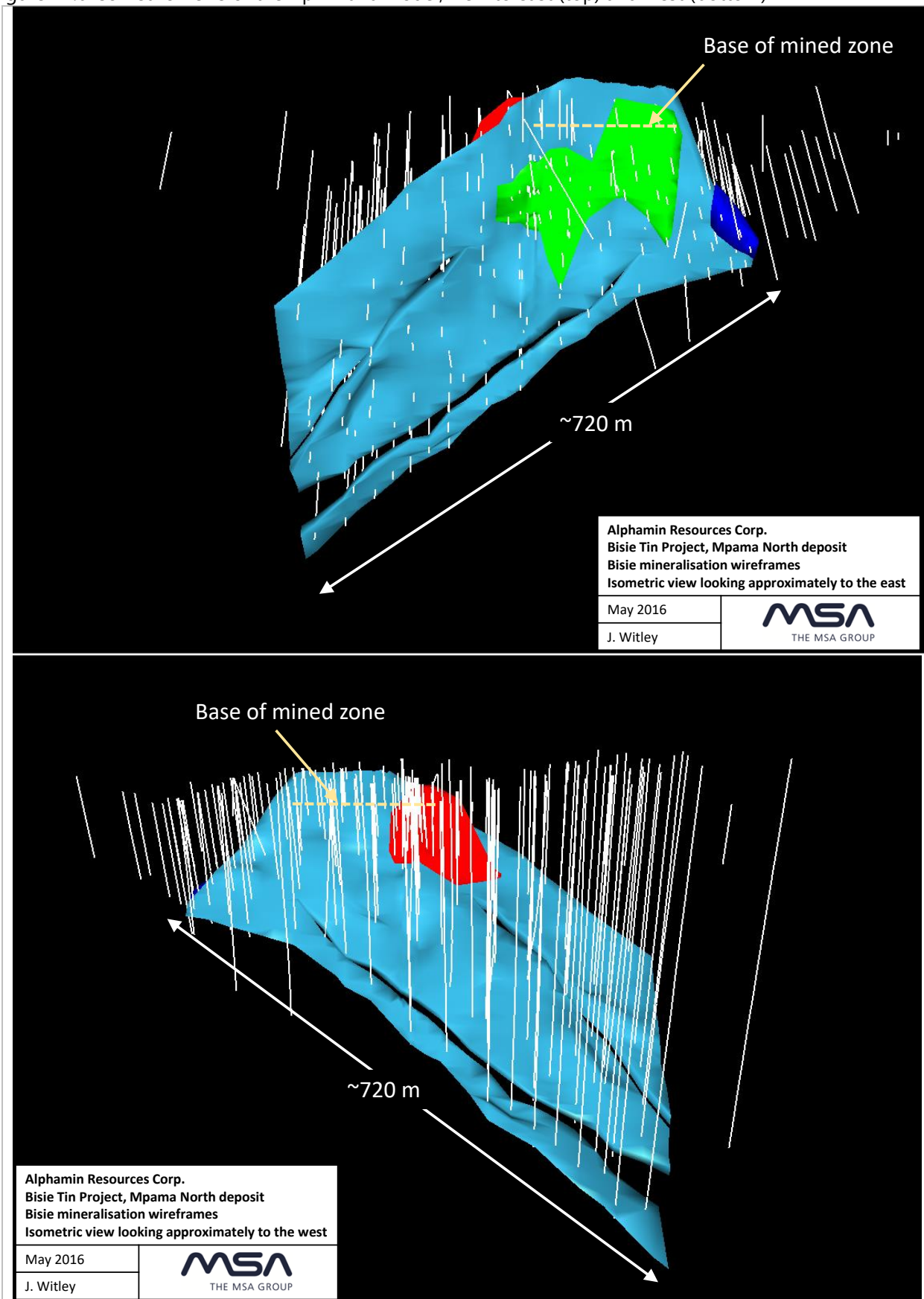

Source MSA

Note: the mined out zone is the area above the horizontal yellow dashed line.

Main Vein Zone – light blue, S1 Block – dark blue, Hangingwall Vein Zone - red, Footwall Vein Zone - green, drillhole traces - white

14.3.3 Oxidation/Weathering Surfaces

No weathering or oxidation surfaces were modelled. Cassiterite is an oxide and is not affected by oxidation. Artisanal mining is assumed to have mined within and below the weathering zone and the majority of the remaining mineralized rock is assumed to be fresh.

14.4 STATISTICAL ANALYSIS OF THE COMPOSITE DATA

The data were composited to 1 m lengths, de-clustered to a cell size of 8 mX, 40 mY and 40 mZ and summary statistics were compiled for each mineralized zone (Table 14.3).

Table 14.3 Summary statistics (de-clustered) of the estimation 1 m composite data

Variable	Number of composites	Min	Max	Mean	CV	Skewness
<u>Main Vein (Main Block)</u>						
Sn %	1481	0.01	60	4.35	1.94	3.4
Cu %	1481	0.00	4.23	0.34	1.45	3.0
Zn %	1481	0.01	3.31	0.16	1.36	5.5
Pb %	1481	0.00	0.65	0.011	3.23	9.7
Ag g/t	1481	0.00	45.67	2.83	1.58	3.5
As ppm	1481	0	10000*	490	2.73	4.5
S %	1481	0.00	10.00*	1.28	1.28	2.6
SG	1481	2.79	6.10	3.31	0.10	3.5
<u>Hangingwall Vein</u>						
Sn %	133	0.00	23.40	1.91	1.80	3.7
Cu %	133	0.00	0.18	0.03	1.25	2.8
Zn %	133	0.00	3.36	0.12	3.14	6.7
Pb %	133	0.00	0.10	0.006	1.76	6.6
Ag g/t	133	0.00	14.39	0.41	3.62	8.4
As ppm	133	0	1316	47	2.50	7.5
S %	133	0	3.70	0.31	1.68	3.7
SG	133	2.80	3.85	3.21	0.04	1.6
<u>Footwall Vein</u>						
Sn %	81	0.02	52.90	4.50	1.88	3.7
Cu %	81	0.00	2.51	0.24	2.14	3.7
Zn %	81	0.00	1.11	0.10	1.17	4.8
Pb %	81	0.00	0.40	0.016	3.11	5.7

Ag g/t	81	0.00	36.0	3.00	1.91	3.0
As ppm	81	0	8184	146	4.10	12.2
S %	81	0.05	6.65	1.23	1.06	2.8
SG	81	2.81	5.22	3.24	0.11	3.0
<u>S1 Block (Main Vein)</u>						
Sn %	32	0.09	40.00	7.01	1.39	1.9
Cu %	32	0.00	1.47	0.33	1.19	1.7
Zn %	32	0.00	0.11	0.04	0.96	0.8
Pb %	32	0.00	0.01	0.002	0.79	2.6
Ag g/t	32	0.00	5.14	1.22	1.19	1.4
As ppm	32	0	8992	1195	1.95	2.4
S %	32	0.23	10.00*	3.29	0.91	1.0
SG	32	2.98	4.50	3.34	0.10	1.7

The statistical analysis revealed:

- Most of the data are in the Main Vein.
- There are few data for the S1 Block. It should be noted that this area is an extension of the Main Vein, separated by interpreted faults.
- The S1 Block is high grade; however it is of small volume and is positioned in line with the main high grade trend of the deposit.
- High tin grades are found in the Footwall Vein where the mineralization typically consists of a narrow cassiterite vein.
- High grades are common within the Main Vein Zone.
- The Hangingwall Vein is characterised by moderate tin and low base metal, arsenic and silver grades.
- Zinc and lead grades are low on average, although sporadic significant grades occur. Copper grades are more significant.
- The histograms are strongly positively skewed, less so for SG.
- The coefficient of variation (CV) is moderate to high for tin grade being between approximately 1.4 and 1.9; but not extreme. High grade cassiterite veins within a low grade host gives rise to a bimodal distribution of very high grades within a larger low grade population.
- The CVs for density are low.
- The CVs for copper, lead and zinc are moderate to high, with high CVs where a few particularly high values occur together with many generally low values.
- The generally high CVs and bimodal tin distribution indicates that linear estimation should be used with caution.

A number of intersections are less than the chosen composite length of 1 m, particularly in the Footwall Vein system where narrow (as little as 0.2 m) high grade intersections occur. These narrow intersections were retained for estimation. Estimation of tin grade directly will assign weights to the narrow intersections that are too high for the volume which they represent. Accumulations of tin grade*density*length were calculated so that the estimation takes into account both the weight and volume of the composite. Density*length was used to back-calculate the tin grade from the accumulations after interpolation.

The summary statistics for the tin grade*density*length accumulations are shown in Table 14.4. The histograms and log probability plots for tin accumulation are shown in Figure 14.7 and the rest of the modelled attributes in Appendix 4. The distributions for the Hangingwall and Footwall Vein systems are less well defined than that of the Main Vein due to fewer data. The accumulation CVs are slightly higher than those for the grades, with the tin accumulation CV being approximately 2 or greater. The distributions for the S1 block of the Main Vein is based on few data so are not meaningful.

Table 14.4 Summary Statistics (de-clustered) of the estimation 1 m composite data for tin accumulation

Variable	Number of composites	Min	Max	Mean	CV	Skewness
<u>Main Vein (Main Block)</u>						
SNPCTDL	1481	0.03	342.50	16.75	2.30	4.6
LEN DEN	1481	2.50	5.94	3.30	0.10	2.8
<u>Hangingwall Vein</u>						
SNPCTDL	133	0	90.04	5.95	2.06	4.4
LEN DEN	133	1.28	3.91	3.05	0.18	-2.0
<u>Footwall Vein</u>						
SNPCTDL	81	0.06	146.54	13.31	1.96	3.7
LEN DEN	81	0.98	4.62	2.92	0.24	-0.6
<u>S1 Block (Main Vein)</u>						
SNPCTDL	32	0.27	179.46	25.49	1.54	2.4
LEN DEN	32	2.97	4.49	3.28	0.10	2.1

Note: SNPCTDL is the product (accumulation) of Sn %, length (m) and SG. LEN DEN is the product (accumulation) of length (m) and SG.

Figure 14.7 Histograms and log probability Plots for Sn accumulation

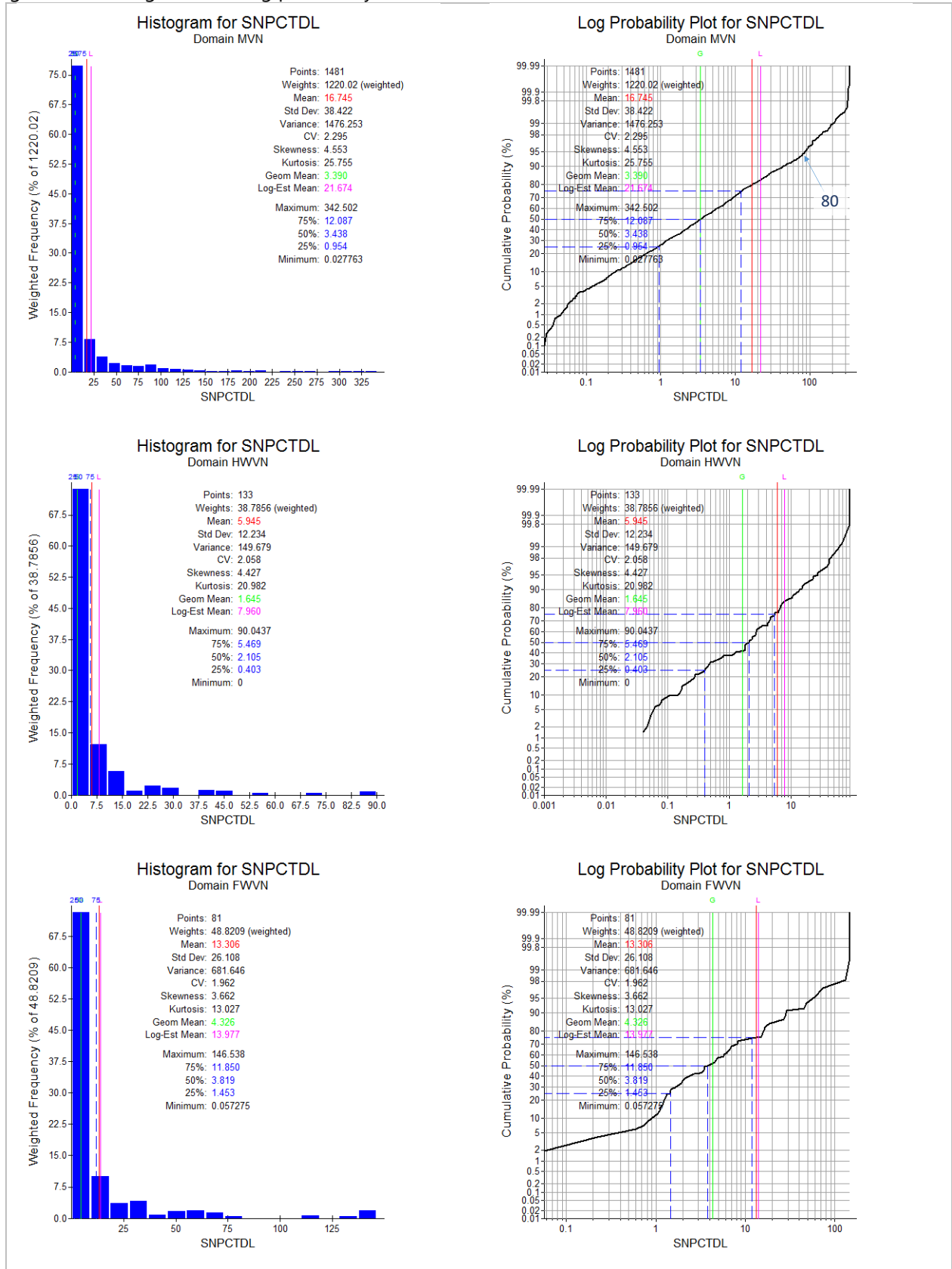

The high grade tin samples represent massive and semi-massive cassiterite veins. The Main Vein histogram exhibits bimodality with a distinct high grade population. The high grade population was separated from the rest of the data within the modelled zones using a threshold of 80 Sn%t/m as noted

as a break in the log probability plot for the Main Vein (Figure 14.7). Approximately 7 % of the Main Vein, 0.7 % of the Hangingwall Vein and 6 % of the Footwall Vein composites are greater than 80 Sn%/m. Summary statistics of the separate grade populations for the high and lower grade tin accumulation data within the vein zones are shown in Table 14.5. Once separated into the two grade populations the CVs are considerably lower than the combined data.

Table 14.5 Summary statistics (de-clustered) of the estimation 1 m composite data for Sn accumulations separated into high and low grade populations

Variable	Number of composites	Min	Max	Mean	CV	Skewness
High Grade (>80 %t/m)						
Main Vein	99	80.34	342.50	133.85	0.47	1.6
Hangingwall Vein	1	90.04	90.04	90.04	ND*	ND*
Footwall Vein	5	117.38	146.54	139.98	0.08	-1.3
S1 Block	3	82.45	179.46	125.27	0.32	0.7
Lower Grade (<80 %t/m)						
Main Vein	1382	0.03	79.44	8.97	1.60	2.7
Hangingwall Vein	132	0.00	69.98	5.34	1.85	3.8
Footwall Vein	76	0.06	74.51	9.57	1.53	2.7
S1 Block	29	0.27	74.34	16.27	1.33	1.7

*ND = Not determined

14.4.1 Cutting and Capping

The log probability plots and histograms of the composite data were examined for outlier values that have a low probability of re-occurrence. These values were capped to a threshold as shown in Table 14.6 Decisions on the capping threshold were guided by breaks in the cumulative log probability plots and the location of the high grade samples with respect to other high grade samples. Top cuts for tin accumulation were applied for a comparative estimate using ordinary kriging of the total tin data, but not when separately estimated using two data sets (>80 %t/m and <80 %t/m). The high grade Sn values occur as a distinct population with a low coefficient of variation and no top-cuts were considered necessary as the high grade data were estimated separately using a restricted search to limit the impact of the high grade samples in areas away from them.

The capping reduced the extreme CV's but lead and arsenic grade CVs in the Main Vein Zone remained high (>2).

Table 14.6 Impact of capping the estimation data

Attribute	Before capping			Cap Value	After Capping		
	Number of Composites	Mean	CV		Number of Composites Capped	Mean	CV
Main Vein							
Sn %	1481	4.35	1.94	37.1	31	4.17	1.78

Cu %	1481	0.34	1.45	2.50	13	0.33	1.42
Zn %	1481	0.16	1.36	1.01	16	0.15	1.07
Pb %	1481	0.011	3.23	0.28	4	0.011	2.97
Ag g/t	1481	2.83	1.58	23.3	10	2.77	1.49
As ppm	1481	490	2.73	-	0	490	2.73
S %	1481	1.28	1.28	-	0	1.28	1.28
Sn %t/m	1481	16.75	2.30	150.00	33	15.26	1.83
<u>Hangingwall Vein</u>							
Sn %	133	1.91	1.80	13.45	4	1.80	1.56
Cu %	133	0.03	1.25	-	0	0.03	1.25
Zn %	133	0.12	3.14	0.97	3	0.09	1.76
Pb %	133	0.006	1.76	0.027	3	0.006	0.89
Ag g/t	133	0.41	3.61	1.02	5	0.22	1.88
As ppm	133	47	2.50	580	2	44	1.64
S %	133	0.31	1.68	-	0	0.31	1.68
Sn %t/m	133	5.95	2.06	47.40	4	5.48	1.53
<u>Footwall Vein</u>							
Sn %	81	4.50	1.88	18.55	6	3.75	1.41
Cu %	81	0.24	2.14	0.69	3	0.15	1.20
Zn %	81	0.10	1.17	0.35	1	0.10	0.89
Pb %	81	0.016	3.11	0.068	5	0.009	1.53
Ag g/t	81	3.00	1.91	19.85	2	2.86	1.78
As ppm	81	146	4.10	1130	3	107	1.76
S %	81	1.23	1.06	3.87	2	1.13	0.83
Sn %t/m	81	13.31	1.96	74.50	6	11.48	1.59
<u>S1 Block (Main Vein)</u>							
Sn %	32	7.01	1.39	-	0	7.03	1.39
Cu %	32	0.33	1.19	0.93	2	0.30	1.19
Zn %	32	0.04	0.96	-	0	0.04	0.96
Pb %	32	0.002	0.79	0.004	3	0.002	0.59
Ag g/t	32	1.22	1.19	-	0	1.22	1.19
As ppm	32	1195	1.95	-	0	1195	1.95
S %	32	3.29	0.91	-	0	3.29	0.91
Sn %t/m	32	25.49	1.54	82.40	3	21.69	1.54

14.5 GEOSTATISTICAL ANALYSIS

14.5.1 Semi-variograms

The 1 m composite data were examined using semi-variograms that were calculated and modelled using Snowden Supervisor software. All attributes were transformed to normal scores distributions and then the spherical semi-variogram models were back-transformed to normal statistical space for use in the grade interpolation process.

Semi-variograms were calculated on the 1 m composite data and modelled within the plane of mineralization with a plunge to the north, this being the major direction of continuity, and the minor direction being across strike. Rotations were aligned for all the attributes estimated. Normalised semi-variograms were calculated so that the sum of the variance (total sill value) is equal to one.

Semi-variograms were modelled with either one or two spherical structures. The nugget effect was estimated by extrapolation of the first two experimental semi-variogram points (calculated at the same lag as the composite length) to the Y axis.

There were insufficient data to calculate robust semi-variograms for the Hangingwall and Footwall Vein zones and the South block, and so the semi-variograms for the Main Vein zone were applied to these zones. The orientation of the South Block is slightly different to the Main Vein and the rotation angles were adjusted slightly to cater for the orientation.

Most variables show strong continuity in the down-plunge direction in excess of the drillhole spacing. The tin grade semi-variogram model exhibits a range of 72 m along plunge and 63 m perpendicular to the plunge direction. The across strike variogram exhibited a range of 5 m. It should be noted that the total data set tin accumulation semi-variograms and tin grade semi-variograms were only used in the check estimates to validate the indicator based estimate.

The semi-variogram model parameters are shown in Table 14.7, the tin grade semi-variograms in Figure 14.8 and variograms for all attributes estimated are presented in Appendix 5.

The reliability of the semi-variograms both in the plane of the mineralization and across strike for each of the variables is generally moderate to good.

Figure 14.8 Semi-variograms for Tin Grade (Main Vein)

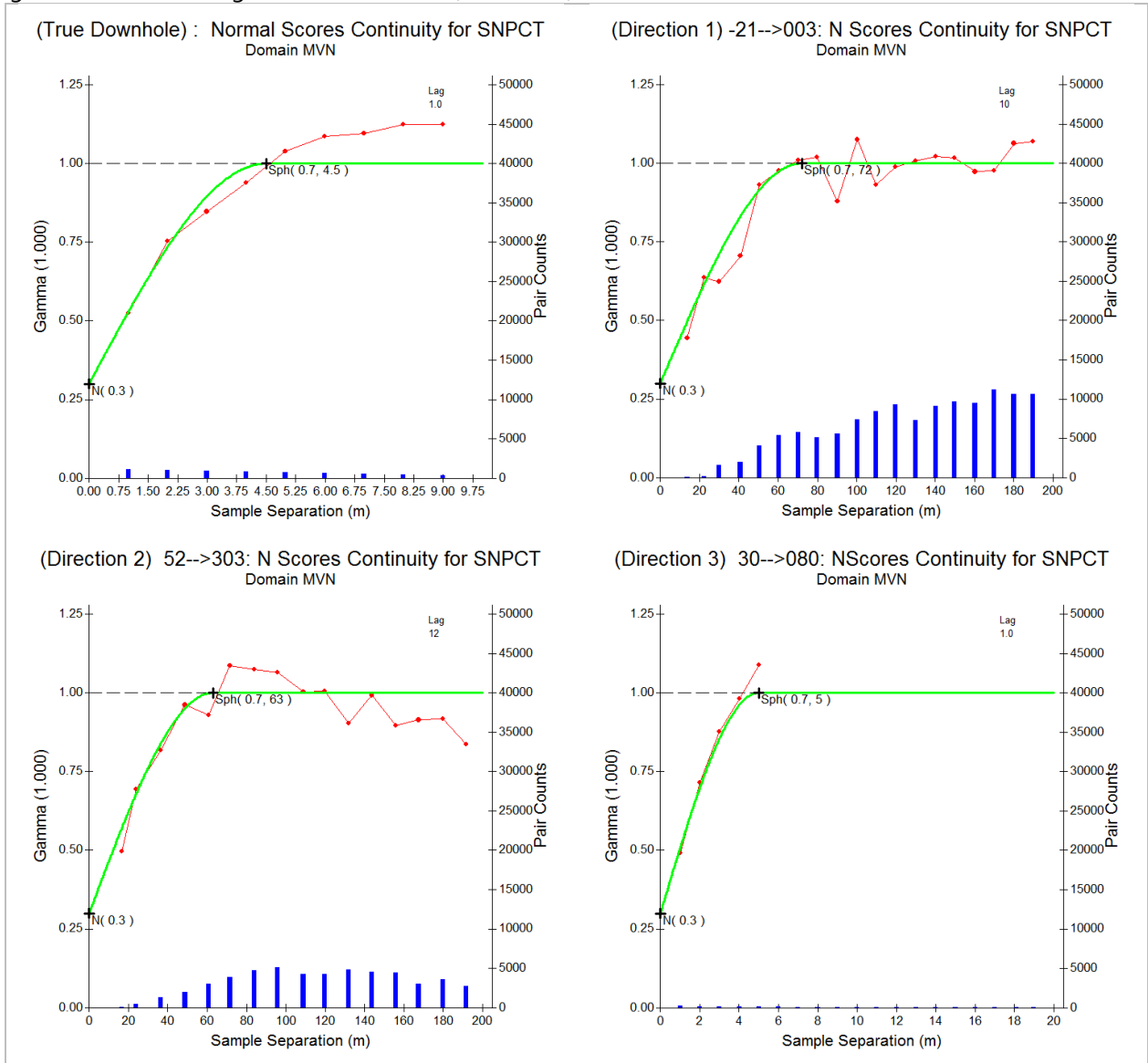

Bisie Tin Project

NI43-101

Table 14.7 Semi-variogram Parameters – Main Vein system, Mpama North

Attribute	Transform	Rotation Angle			Rotation Axis			Nugget Effect (C0)	Range of First Structure (R1)			Sill 1 (C1)	Range of Second Structure (R2)			Sill 2 (C2)
		1	2	3	1	2	3		1	2	3		1	2	3	
Grades and Density																
Sn %	NS	80	62	-135	Z	X	Z	0.42	72	63	5	0.58				
Ag g/t	NS	80	62	-135	Z	X	Z	0.09	50	50	4	0.60	125	85	12	0.31
Cu %	NS	80	62	-135	Z	X	Z	0.03	200	85	11	0.97				
Zn %	NS	80	62	-135	Z	X	Z	0.07	50	65	4	0.63	110	65	11	0.30
Pb %	NS	80	62	-135	Z	X	Z	0.34	120	70	9	0.66				
S %	NS	80	62	-135	Z	X	Z	0.16	45	65	3	0.37	120	80	12	0.47
As ppm	NS	80	62	-135	Z	X	Z	0.17	30	15	6.5	0.54	170	50	6.5	0.29
Density	NS	80	62	-135	Z	X	Z	0.26	20	20	3	0.35	140	55	17	0.39
Accumulations																
Sn %.t/m	NS	80	62	-135	Z	X	Z	0.44	75	64	5	0.56				
Length*density	NS	80	62	-135	Z	X	Z	0.19	100	50	3	0.24	100	50	25	0.57

Note: rotation angle for S1 Block adjusted to 90, 55, 0135 to cater for the different orientation to the Main Vein.

14.5.2 Indicator Semi-variograms

At Mpama North, extreme high grades associated with vein cassiterite occur together with lower grade disseminated cassiterite. A threshold of approximately 80 Sn%/m separates the two distributions. The continuity of the higher grade mineralization in the Main Vein zone was modelled using indicator semi-variograms, whereby the data was transformed to a value of 0 if less than 80 Sn%/m or 1 if greater than 80 Sn%/m, and semi-variograms were calculated using the indicator values. The indicator model parameters are shown in Table 14.8 and the semi-variograms in Figure 14.9. The semi-variogram was modelled with a range of 60 m in the plunge direction, 42 m perpendicular to plunge and 5 m across strike.

Figure 14.9 Indicator semi-variograms for 80Sn%/m (Main Vein)

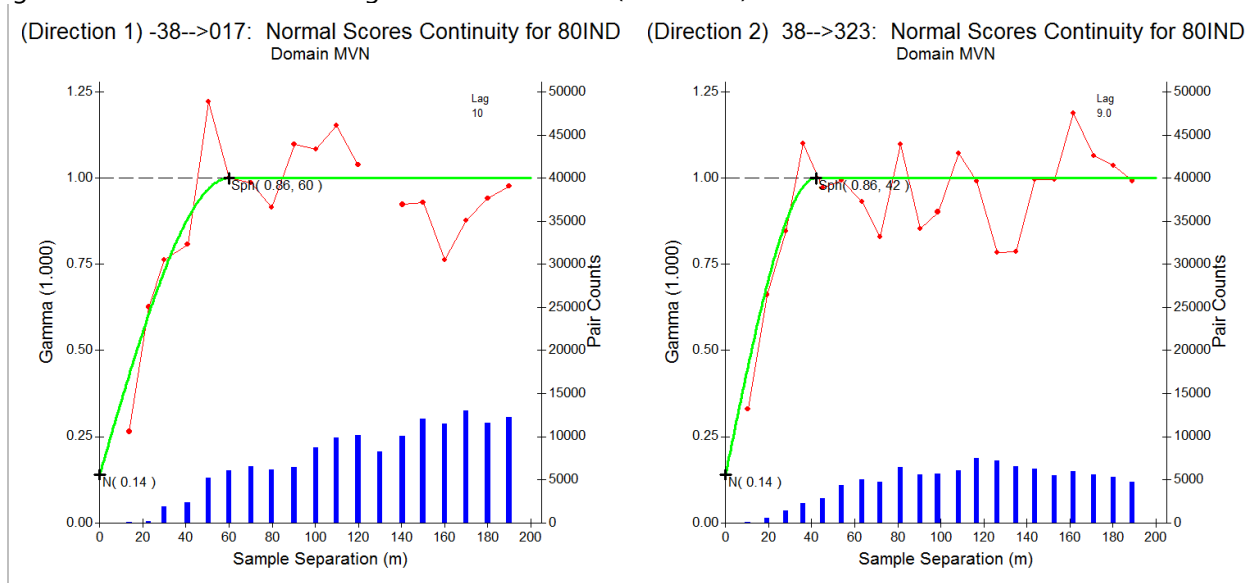

Table 14.8 Indicator semi-variogram – Main Vein System, Mpama North

Attribute	Rotation Angle			Rotation Axis			Nugget Effect (C0)	Range of First Structure (R1)			Sill 1 (C1)	Range of Second Structure (R2)			Sill 2 (C2)
	1	2	3	1	2	3		1	2	3		1	2	3	
Indicator 80Sn%/m	80	62	-135	Z	X	Z	0.34	60	42	3.5	0.66	-	-	-	-

Note: rotation angle for S1 Block adjusted to 90, 55, 0135 to cater for the different orientation to the Main Vein.

14.5.3 Above and Below Threshold Semi-Variograms

The continuity of tin mineralization was modelled separately for the high grade subset (>80 Sn%/m) and the low grade subset (<80 Sn%/m). Strong down-plunge continuity was noted for the below threshold population, however omni-directional semi-variograms in the plane of mineralization were modelled for the above threshold population, as robust semi-variograms could not be modelled in all three directions. The semi-variograms are shown in Figure 14.10 and Figure 14.11 and the semi-variogram parameters in Table 14.9.

Table 14.9 Above and below threshold semi-variogram parameters – Main Vein system, Mpama North

Attribute	Rotation Angle			Rotation Axis			Nugget Effect (C0)	Range of First Structure (R1)			Sill 1 (C1)	Range of Second Structure (R2)			Sill 2 (C2)
	1	2	3	1	2	3		1	2	3		1	2	3	
>80Sn%t/m	80	62	-135	Z	X	Z	0.60	73	73	3	0.40	-	-	-	-
<80Sn%t/m	80	62	-135	Z	X	Z	0.40	70	35	3	0.22	70	63	5.5	0.38

Note: rotation angle for S1 Block adjusted to 90, 55, 0135 to cater for the different orientation to the Main Vein.

Figure 14.10 Threshold semi-variograms for Main Vein Zone <80Sn%t/m

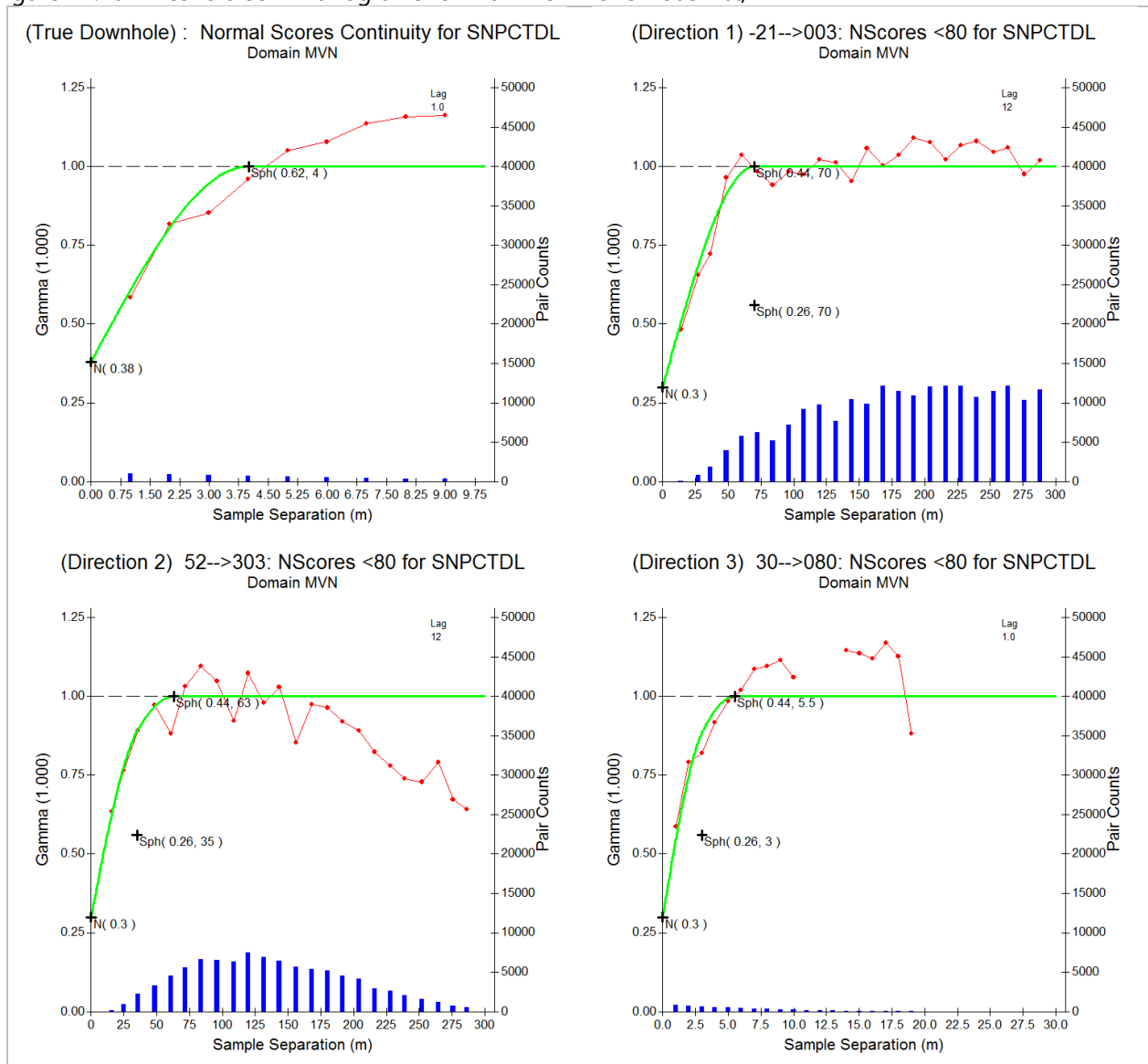
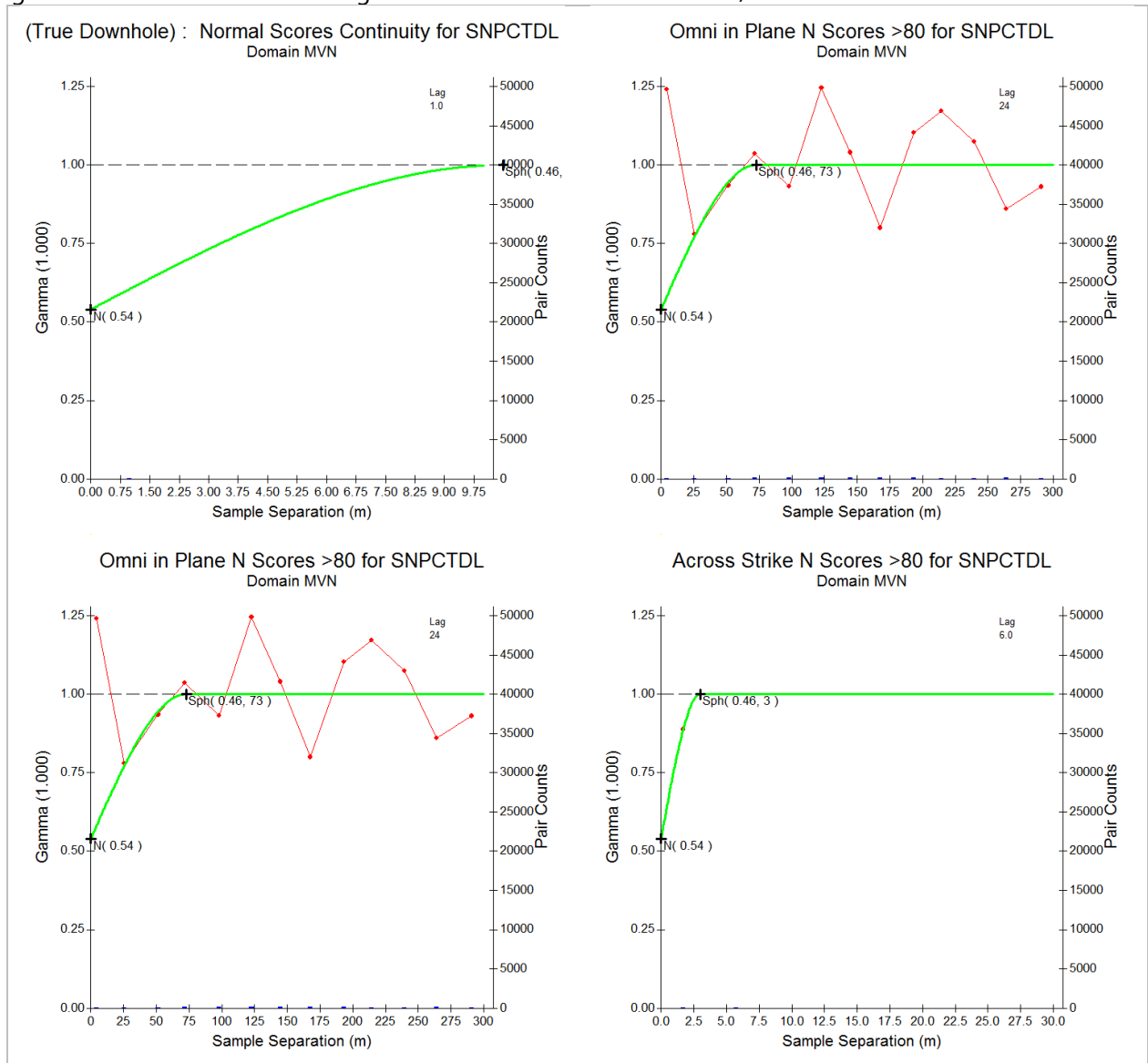

Figure 14.11 Threshold semi-variograms for Main Vein Zone >80Sn%/m



14.6 BLOCK MODELLING

Block models were rotated in the dip direction in order to best fit the orientation of the mineralized zones. The block model prototype parameters are shown in Table 14.10. The cells were split to a minimum sub-cell of 0.20 mX by 2 mY by 2 mZ in order to fill the wireframe model boundaries accurately and create blocks where the mineralization is narrow.

Table 14.10 Block model prototype parameters for Bisie, Mpama North

Block Size (m)			Model origin			Rotation Angle			Rotation Axis			Number of cells		
X	Y	Z	X	Y	Z	1	2	3	1	2	3	X	Y	Z
2	20	10	582500	9885000	-150	0	28	0	Z	Y	Z	642	108	112

Block models were created by filling below the topographic surface and above and below the “mined-out” area surface using the same model prototypes as shown in Table 14.10. The topographic model and “mined-out” models were added to the mineralization models, so that the block model cells were coded as either mined or un-mined, and the model cells above the topographic surface were removed.

A waste model was made at least 20 m either side of the vein models to assist with mine planning.

The dynamic anisotropy process in Datamine Studio 3 software was used to control the estimate so that the search parameter directions were modified to follow the local shape of the mineralized zones. This was achieved by estimating a dip and direction into each block model cell based on the dip and direction of the wireframes. The search parameters used to estimate the dynamic angles into the block model are shown in Table 14.11.

Table 14.11 Dynamic anisotropy search parameters for Bisie, Mpama North

Search Distance (m)			Search Angle			Search Axis			Number of samples		Search Multiplier 1	Search Multiplier 2
1	2	3	1	2	3	1	2	3	Min	Max		
50	25	7	80	62	0	Z	X	Z	3	5	6	-

14.6.1 Validation of the Block Model Volumes with the Wireframe Volumes

The filling of the wireframes by the block model cells was validated by comparing the volume of the rotated block model with the volume of the wireframe (Table 14.12).

Table 14.12 Validation of block model filling

Zone	Wireframe Volume (m ²)	Block Model Volume (m ²)	Percent Difference
Main Vein	1,597,157	1,582,542	-0.9
Hangingwall Vein	30,497	30,477	-0.1
Footwall Vein	46,725	46,558	-0.4
South 1 Block	21,052	21,476	2.0

The volume of the model compares well with the wireframe volume.

14.7 ESTIMATION

Attributes were estimated into the individual mineralized zones using the capped 1 m composite drillhole sample data for each zone. Ordinary kriging was used to estimate the attributes into the block model cells using parent cell estimation.

The search distance and the rotation angles that defined the search ellipses were based on the semi-variogram model for each attribute. The minimum number of composites required for a high confidence estimate was 8 and the maximum number 24. The minimum number of samples required for an estimate was reduced to 4 for the narrower Hangingwall and Footwall Vein zones and 6 for the

S1 block. If an estimate was not achieved within the search ellipse volume, the search ellipse was expanded by 50 % and again by a factor of 10. Should an estimate still not be achieved, a larger search ellipse was used sourcing up to 36 composites to estimate grades close to the local average when away from the drillhole data. This was only necessary for an insignificant number of cells.

Discretisation was set at 5 strike by 4 dip by 2 in the across strike direction of the blocks. Dynamic anisotropy was used to guide the search in the local direction of the mineralized zones. The ordinary kriging search parameters are shown in Table 14.13.

Ordinary kriging was also used for the waste model using the same estimation parameters as for the Main Vein zone.

14.7.1 Estimation of tin accumulation.

A different approach was used for the tin accumulation whereby the probability of a block having an accumulation value above the 80 Sn%/t/m threshold was estimated for each block in the model using indicator kriging.

In order to restrict the influence of the high grade values away from the high grade intersections the indicator estimate was restricted to a single short search distance. This distance was defined by projection of the linear part of the indication semi-variogram to the sill value rather than the range of the sill from the spherical model, as illustrated in Figure 14.12. Any cell that was not estimated with an indicator value in the first search was assigned a zero indicator value (probability of above threshold being nil) and therefore samples from the high grade population were restricted from estimating beyond a relatively short distance away from their locations.

Figure 14.12 Illustration of the search distance derived from the linear portion of the indicator semi-variogram model

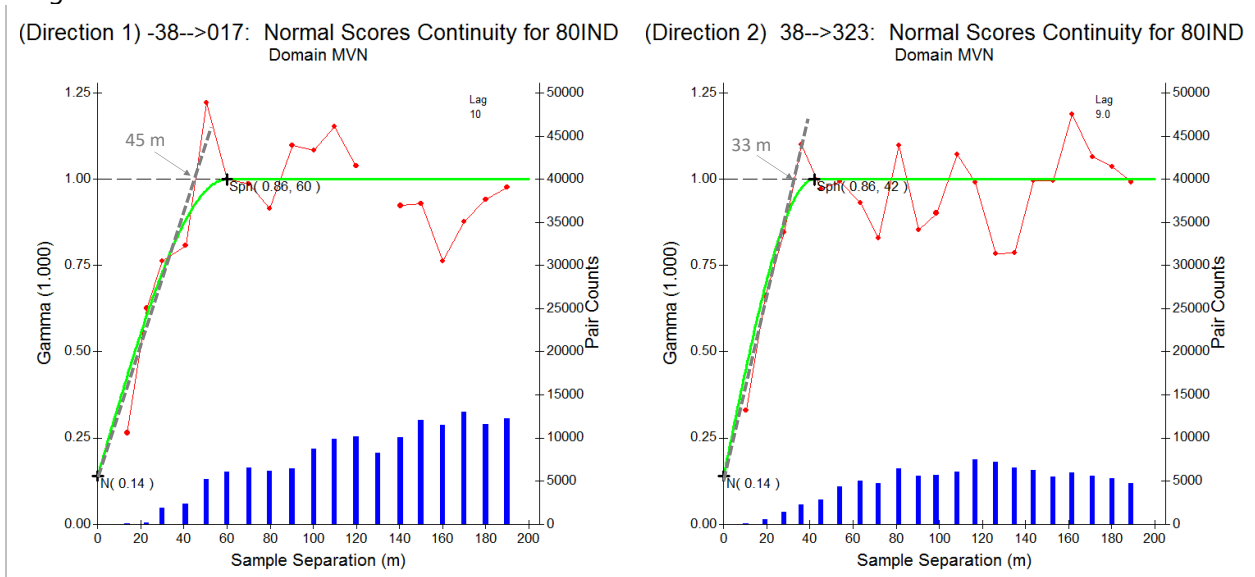

Each cell was then estimated with the tin accumulation values above 80 %Sn%/t/m and again with tin accumulation values below 80 Sn%/t/m. The estimated accumulation value using the high grade data was multiplied by the probability of the cell being above the threshold and the estimated accumulation value using the lower grade data was multiplied by the probability of the cell being below the threshold. The two values added together result in an estimated accumulation value for each cell in the block model.

The estimation parameters for length*density were aligned with the tin accumulation so that both estimates use the same samples to ensure that the transformation back to the grade values is correct.

The search parameters for the indicator estimation are shown in Table 14.14 Search parameters for Mpama North – indicator approach.

Bisie Tin Project
NI43-101

Table 14.13 Search parameters for Mpama North – ordinary kriging

Attribute	Search Distance (m)			Search Angle			Rotation Axis			First Search Volume		Factor	Search Multiplier 2		Factor	Search Multiplier 3	
	1	2	3	1	2	3	1	2	3	Min Num.	Max Num.		Min Num*	Max Num.		Min Num*	Max Num.
Grades and Density																	
Sn %	72	63	5	80	62	-135	Z	X	Z	8	24	1.5	8	24	10	8	24
Ag g/t	125	85	12	80	62	-135	Z	X	Z	8	24	1.5	8	24	10	8	24
Cu %	200	85	11	80	62	-135	Z	X	Z	8	24	1.5	8	24	10	8	24
Zn %	110	65	11	80	62	-135	Z	X	Z	8	24	1.5	8	24	10	8	24
Pb %	120	70	9	80	62	-135	Z	X	Z	8	24	1.5	8	24	10	8	24
S %	120	80	12	80	62	-135	Z	X	Z	8	24	1.5	8	24	10	8	24
As ppm	170	50	6.5	80	62	-135	Z	X	Z	8	24	1.5	8	24	10	8	24
Density	140	55	17	80	62	-135	Z	X	Z	8	24	1.5	8	24	10	8	24
Accumulations																	
Sn %.t/m	75	64	5	80	62	-135	Z	X	Z	8	24	1.5	8	24	10	8	24
Length*density	75	64	5	80	62	-135	Z	X	Z	8	24	1.5	8	24	10	8	24

Note: The minimum number of composites used for the Hangingwall and Footwall vein zones is 4 and for the S1 Block is 6. Rotation angle for S1 Block adjusted to 90, 55, 0135 to cater for the different orientation to the Main Vein.

Bisie Tin Project
NI43-101

Table 14.14 Search parameters for Mpama North – indicator approach

Attribute	Search Distance (m)			Search Angle			Rotation Axis			First Search Volume		Factor	Search Multiplier 2		Factor	Search Multiplier 3	
	1	2	3	1	2	3	1	2	3	Min Num*	Max Num.		Min Num*	Max Num.		Min Num*	Max Num.
Indicator 80Sn%/t/m	45	33	3.5	80	62	-135	Z	X	Z	4	10	-	-	-	-	-	-
Sn %.t/m > 80	73	73	3	80	62	-135	Z	X	Z	4	10	1.5	4	10	10	4	10
Sn %.t/m < 80	70	35	5	80	62	-135	Z	X	Z	8	24	1.5	8	24	10	8	24
L*SG (Sn%.t/m > 80)	73	73	3	80	62	-135	Z	X	Z	4	10	1.5	4	10	10	4	10
L*SG (Sn%.t/m < 80)	70	35	5	80	62	-135	Z	X	Z	8	24	1.5	8	24	10	8	24

Note: The minimum number of composites used for the Hangingwall and Footwall vein zones is 4 and for the S1 Block is 6 for the <80 Sn%/m population. Rotation angle for S1 Block adjusted to 90, 55, 0135 to cater for the different orientation to the Main Vein.

The estimates of tin grade*density*length were divided by the estimate of density*length for each block in order to obtain the estimated grade for tin. As well as the indicator approach, tin accumulation was estimated using ordinary kriging and the two results were compared in order to ensure the indicator approach is robust.

14.8 VALIDATION OF THE ESTIMATES

The models were validated by:

- visual examination of the input data against the block model estimates,
- sectional validation,
- comparison of the input data statistics against the model statistics,
- comparison of the indicator model with the ordinary kriged model.

The block model was examined visually in sections to ensure that the drillhole grades were locally well represented by the model. The model validated reasonably well against the data, although there is a minor degree of smoothing, the high and low grade areas being well represented by the model. Examples of sections showing the block model and drillholes shaded by Sn% are shown in Figure 14.13 Note that the section on 9,885,705 mY illustrates both the Main Vein and the Footwall Vein zone and that the waste model surrounding the vein systems is included in both illustrations.

Figure 14.13 Sections through block model and drillhole data illustrating correlation between model and data (note sections are 255 m apart)

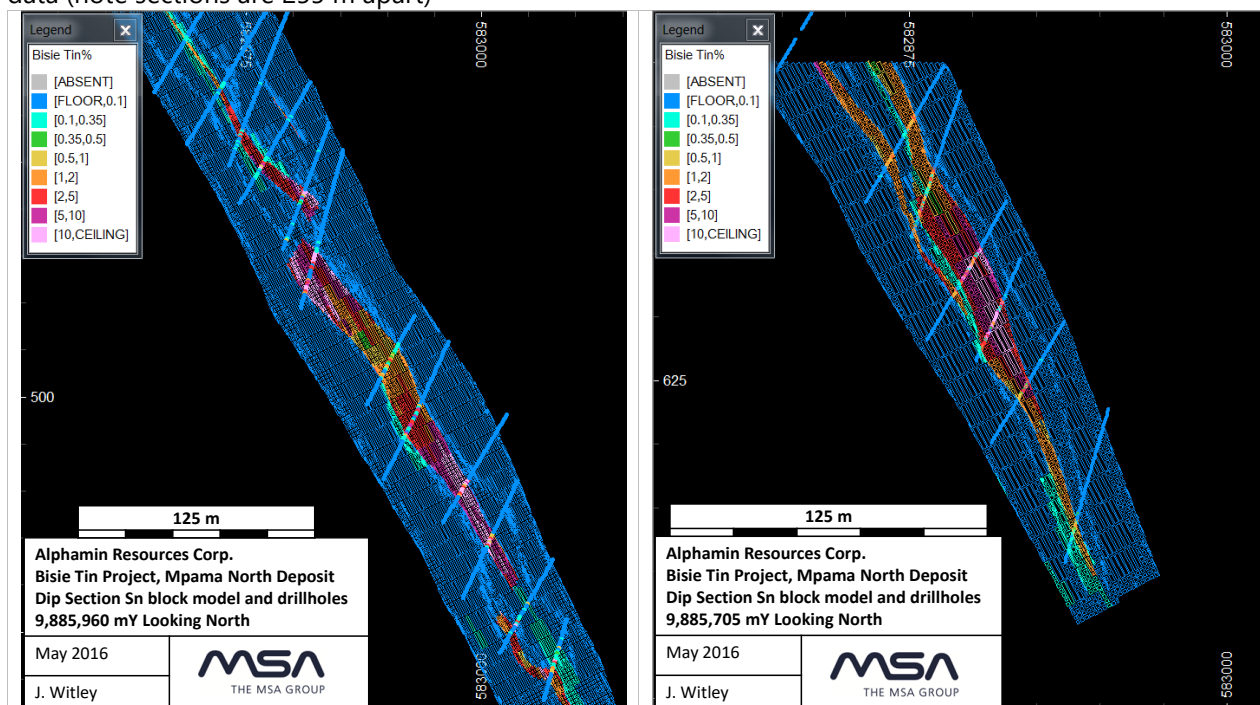

Sectional validation plots were constructed for tin grade in order to compare the average grades of the block model against the input data along a number of corridors in various directions through the deposit. Samples of the sectional validation plots for tin grade (model grades back calculated from the accumulations) are shown in Figure 14.14. These show that the estimates are smoother than the data, yet retain the broad grade trends across the deposit.

Figure 14.14 Sectional validation plots for Sn% (model grades back calculated from the accumulations)

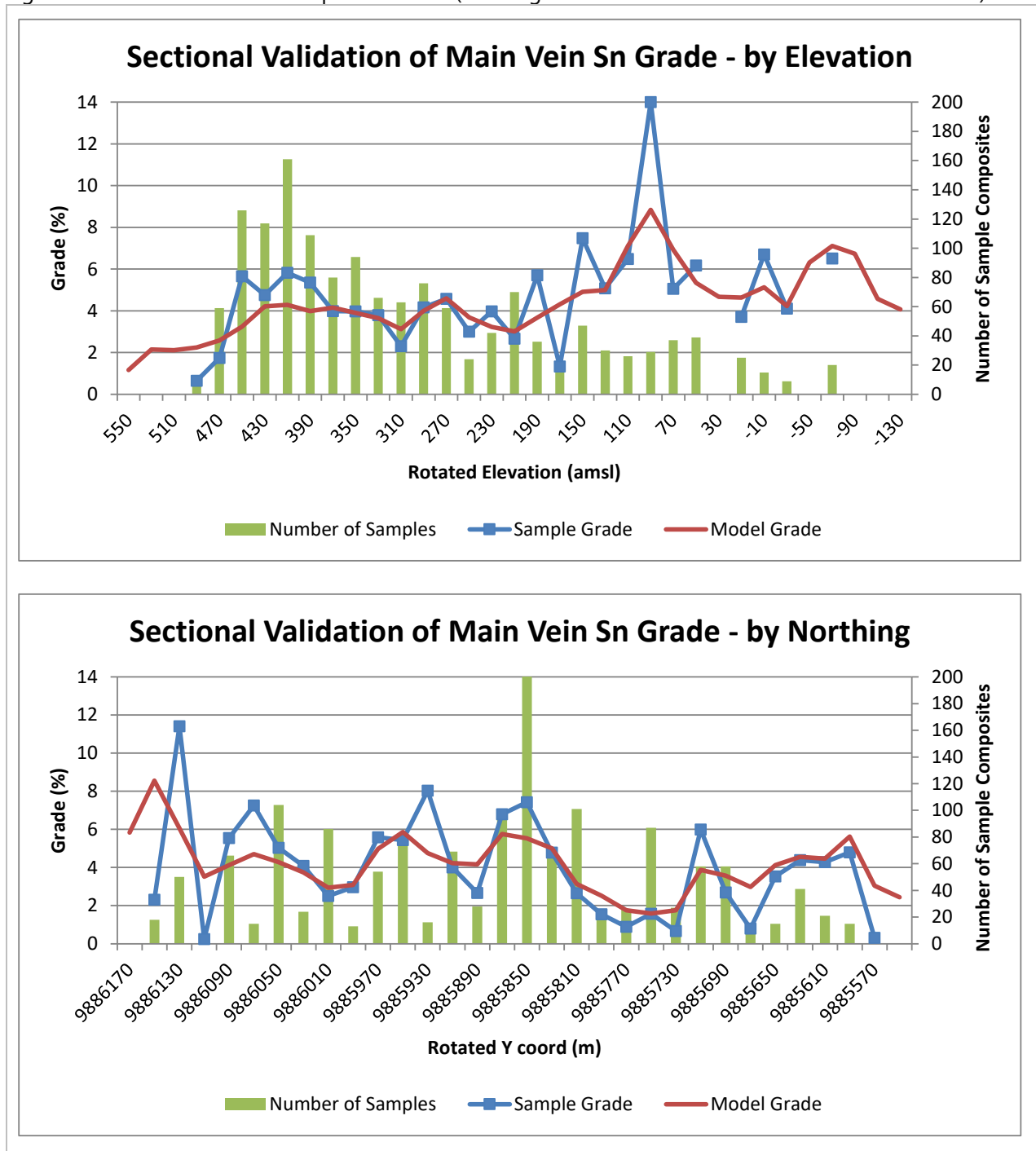

As a further check, the length-density weighted grades of the drillholes were compared with the model grade (Table 14.15) it being expected that the model grade will be slightly lower than the data grade due to the skewed data distribution. The model and the data averages compare well for most areas and attributes, the comparison being poorer in the zones with less data that are sensitive to the arrangement of high and low grades.

There are few samples in the South 1 Block, which covers a small area, and the estimate is sensitive to their location, hence the large difference between the input data and model grade, the indicator approach applied having restricted the impact of the particularly high tin grades.

The higher arsenic value in the S1 Block model compared to the data is due to the highest arsenic values being in the central location of the three drillholes that has the most influence in the model.

The large difference between the model arsenic and silver grades and the data for the Footwall Vein is due to the particularly high arsenic and silver grades being clustered towards the north edge of the model area that is well drilled. The de-clustering applied has not adequately catered for this and larger areas of the model are estimated with sparser lower grade data.

Table 14.15 Comparison between drillhole and model data values

	Variable	Mean Model	Mean full intersection composite (length density weighted)	Mean 1 m composite data	Mean 1 m composite data (Capped)
Main Vein	Sn %	4.32 (4.26)	5.11	4.35	4.17
	Ag g/t	2.54	2.67	2.83	2.77
	Cu %	0.31	0.32	0.34	0.33
	Zn %	0.15	0.15	0.16	0.15
	Pb %	0.010	0.011	0.011	0.011
	S %	1.24	1.34	1.28	1.28
	As ppm	443	399	490	490
	Density	3.30	3.31	3.31	3.31
Hangingwall Vein	Sn %	1.96 (2.18)	1.72	1.91	1.80
	Ag g/t	0.20	0.27	0.41	0.22
	Cu %	0.03	0.04	0.03	0.03
	Zn %	0.08	0.16	0.12	0.09
	Pb %	0.005	0.006	0.006	0.006
	S %	0.28	0.43	0.31	0.31
	As ppm	46	50	47	44
	Density	3.21	3.21	3.21	3.21
Footwall Vein	Sn %	4.28 (3.73)	3.93	4.50	3.75
	Ag g/t	1.72	3.38	2.97	2.86
	Cu %	0.12	0.24	0.24	0.15
	Zn %	0.08	0.10	0.10	0.10
	Pb %	0.008	0.020	0.016	0.009
	S %	1.10	1.19	1.23	1.13
	As ppm	82	159	146	107
	Density	3.18	3.18	3.24	3.24
S1 Block	Sn %	5.48 (7.03)	8.18	7.01	6.73
	Ag g/t	1.12	1.32	1.22	1.22
	Cu %	0.27	0.34	0.33	0.30

Zn %	0.03	0.04	0.04	0.04
Pb %	0.002	0.002	0.002	0.002
S %	3.27	3.09	3.29	3.29
As ppm	1405	1158	1195	1195
Density	3.35	3.35	3.34	3.34

Note: Tin, grades are back calculated mean accumulation grades. Figures in brackets are from the ordinary kriged estimate

The indicator model is of similar grade to the ordinary kriged model for the Main Vein, lower for the Hangingwall Vein and the South 1 Block, and higher for the Footwall Vein.

In order to assess the impact of the indicator approach on a more local scale, sectional validation plots were produced that compare the grade of the two models and the estimation data in slices across the deposit (Figure 14.15). These demonstrate that the two estimates compare well and that the indicator model is less smoothed than the ordinary kriged model. High tin grades have not spread away from the edges of the data extents in the indicator model.

Figure 14.15 Sectional validation plots for Sn% - Indicator versus ordinary kriged estimate

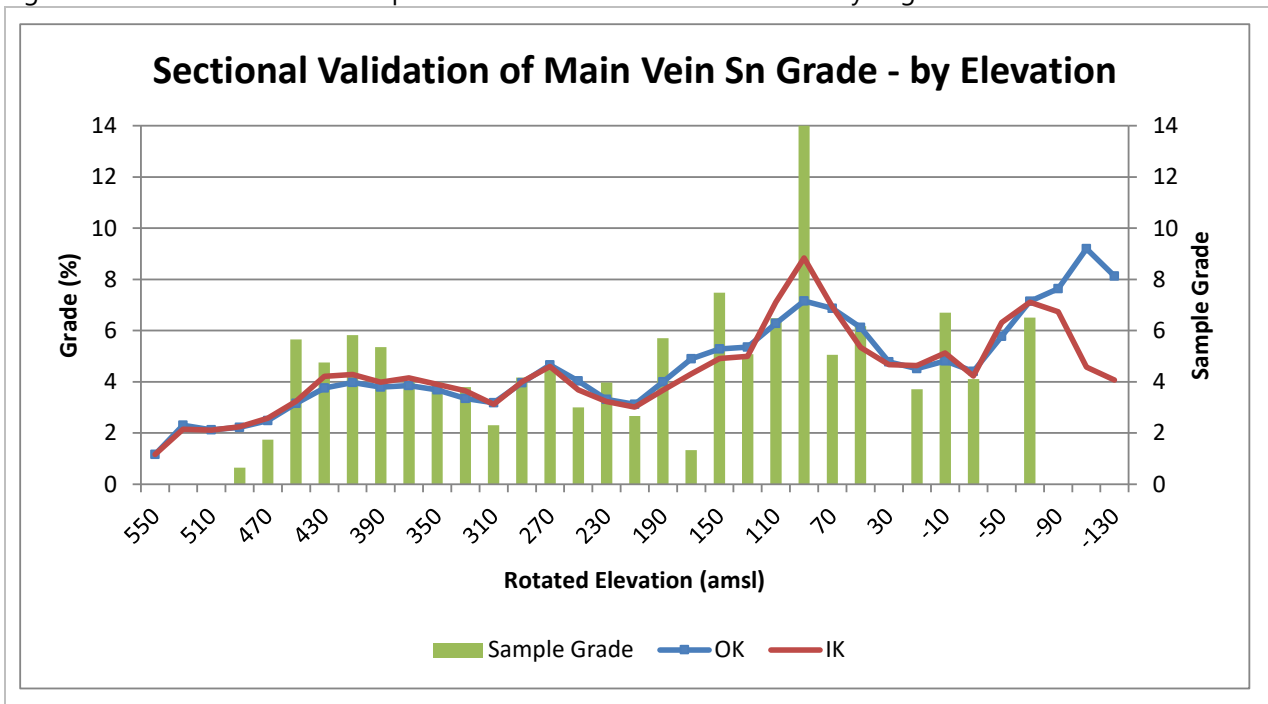

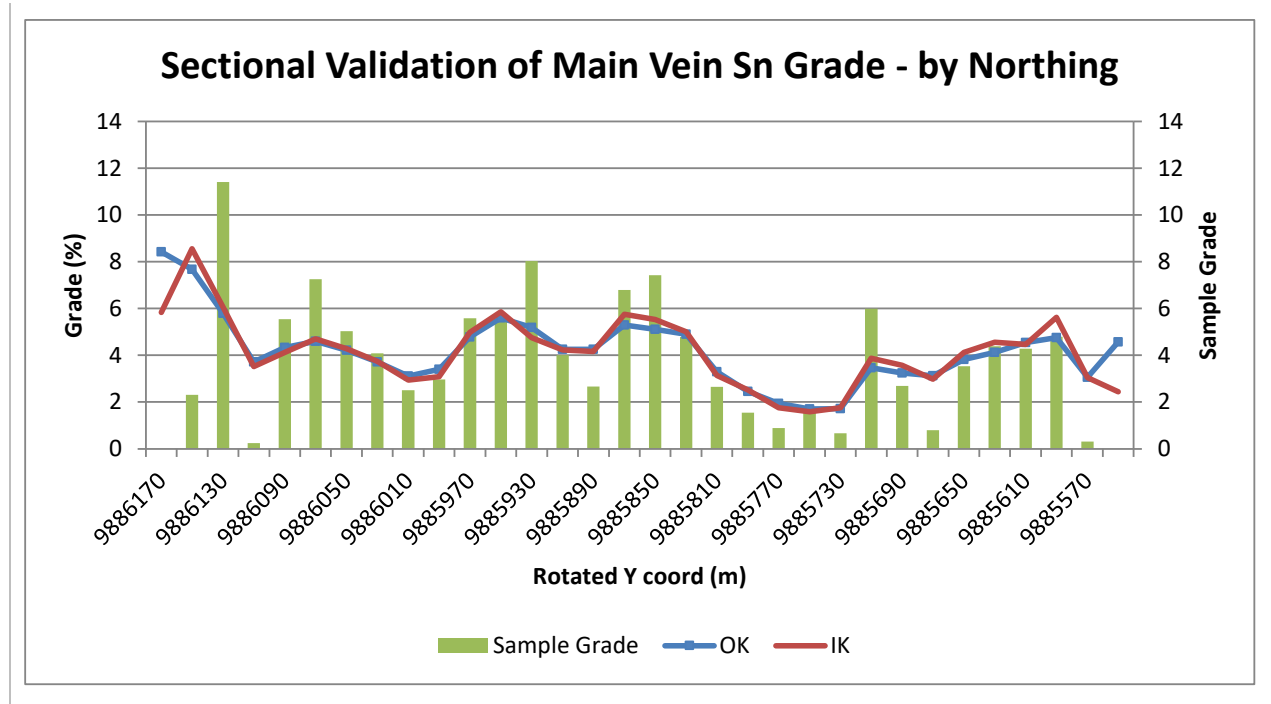

14.9 MINERAL RESOURCE CLASSIFICATION

Classification of the Mpama North Mineral Resource was based on confidence in the data, confidence in the geological model, grade continuity and variability and the frequency of the drilling data. The main considerations in the classification of the Mpama North Mineral Resource are as follows:

- All of the data that inform the Mineral Resource have been collected by Alphamin. These data have been collected using acceptable principles and the high grade assays have been demonstrated to be of reasonable accuracy.
- The initial general interpretation of the geological framework of the Mineral Resource of a steeply dipping thick slab of chlorite schist containing a number of cassiterite veins and zones of disseminated cassiterite was confirmed by the drilling in 2014 and 2015.
- The interpretation has been refined to include two faults that has allowed for the inclusion of two drillholes previously rejected from the estimate due to concerns on their position, however the nature of these faults is not well understood, there being evidence that the faulting is at a close angle to the chlorite schist. It is likely that additional faults occur that cannot be confidently resolved at the scale of the drilling grid.
- The drillhole grid of approximately 50 m in dip by 50 m in strike is sufficient to delineate the general shape. Several areas have been drilled close to 25 m spacing, confirming the geological continuity. The individual veins appear to have limited continuity although the envelope containing the vein systems is continuous within the drilling grid with the dip and plunge of the deposit being well understood.
- Semi-variogram ranges for tin are in excess of the general drillhole spacing in most areas.
- Short range continuity of the high grade zones has been confirmed by the closer spaced metallurgical sample drilling program. Individual high grade zones of mineralization have

been demonstrated to be continuous over approximately 25 m in the dip (east-west direction) and at least 25 m in the plunge direction.

- The deposit is open down-plunge to the north. Several drillholes have been drilled close to the up and down dip edges of the mineralized zone that have constrained its limit. The Footwall and Hangingwall Vein zones are smaller in extent than the Main Vein zone and contain fewer holes; these zones being sensitive to data variability.
- The grade model is necessarily smoothed due to the high variability of the cassiterite mineralization; however most of the deposit is drilled well enough to be able to estimate to a degree of confidence that will allow a reasonable assessment of the viability of a mining operation.

Given the aforementioned factors the Mpama North Mineral Resource at Bisie has been classified using the following criteria:

- An area drilled at a grid spacing of approximately 25 m, also containing the closely spaced metallurgical drilling, has been classified as a Measured Mineral Resource. Kriging efficiency (which is a measure of the quality of the estimate) is above 50% in this area, and slope of regression (which is a measure of how smoothed the estimate is) is above 80%.
- Areas where the deposit has been drilled at a grid spacing of closer than 50 mN by 50mE were considered for Indicated Mineral Resources. Kriging efficiency is above 0% in this area, and slope of regression is above 50%.
- The remaining area of the model within the drilling grid was classified as Inferred Mineral Resources. Should areas of the grade shell show considerable deviation from the general structural trend, the affected area was classified as Inferred Mineral Resources regardless of the drillhole spacing.
- Inferred Mineral Resources were extrapolated in the plane of the mineralization for a maximum distance of 20 m up- and down-plunge from the nearest drillhole intersection, as the peripheries of the mineralization appear to have been affected by faulting that could terminate the mineralization abruptly.
- The block offset from the main portion of the Mineral Resource to the south (the S1 block) has been classified as Inferred, there being insufficient drillhole intersections in this block to reliably estimate it.

The classified areas are shown in Figure 14.16 for the Main Vein zone and Figure 14.17 for the Hangingwall and Footwall Vein zones.

To the best of the QP's knowledge there are no environmental, permitting, legal, tax, socio-political, marketing or other relevant issues which may materially affect the Mineral Resource estimate as reported in this technical report, aside from those mentioned in Item 4 of this report.

The Mineral Resources will be affected by further infill and exploration drilling which may result in increases or decreases in subsequent Mineral Resource estimates. Inferred Mineral Resources are considered to be high risk estimates that may change significantly with additional data. It cannot be assumed that all or part of an Inferred Mineral Resource will necessarily be upgraded to an Indicated Mineral Resource as a result of continued exploration. The Mineral Resources may also be affected by

subsequent assessments of mining, environmental, processing, permitting, taxation, socio-economic and other factors.

Figure 14.16 Mineral Resource classification, Main Vein - long section looking east

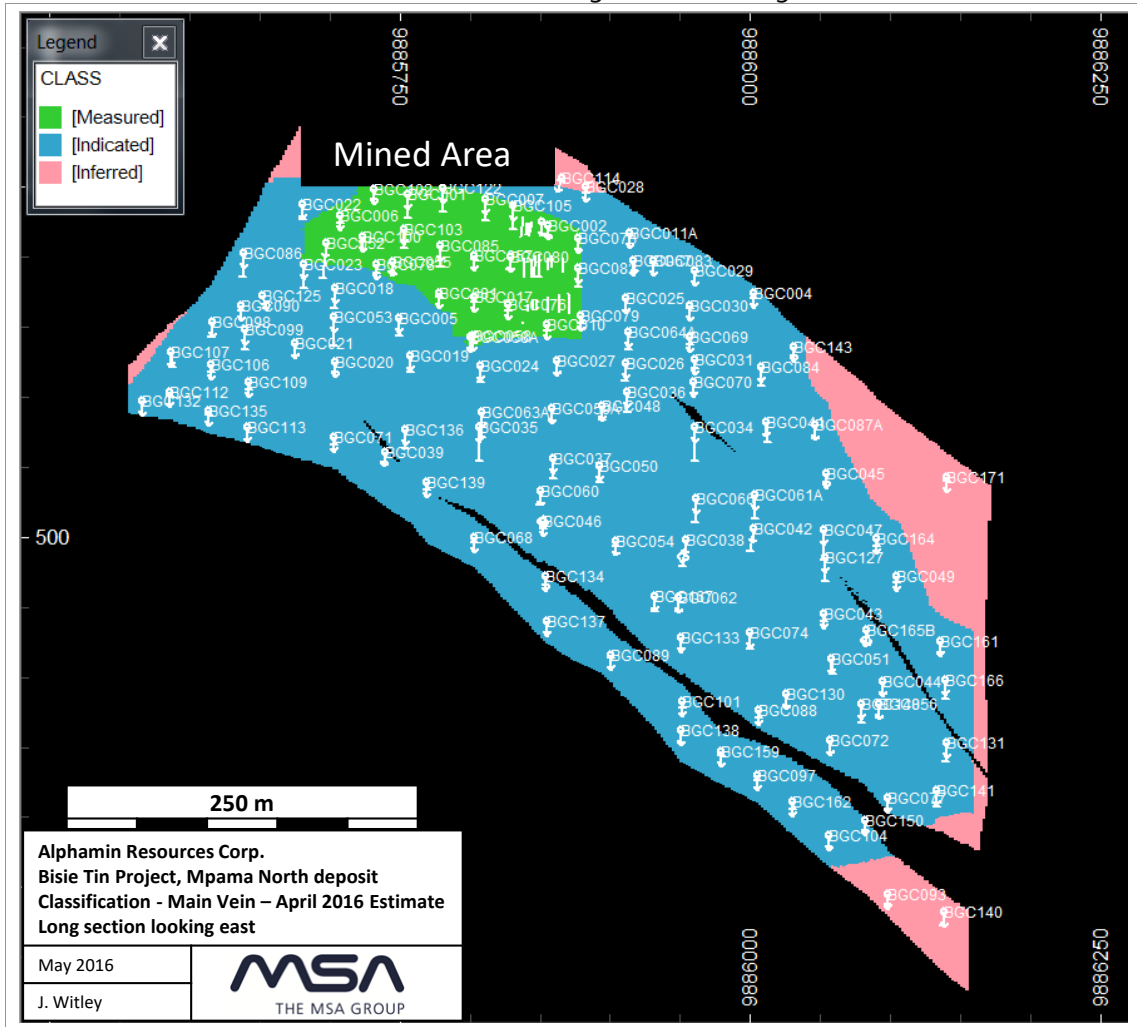

Drillhole intersections shown in white.

Figure 14.17 Mineral Resource classification, Hangingwall Vein (Top) and Footwall Vein (Bottom) - long sections looking east

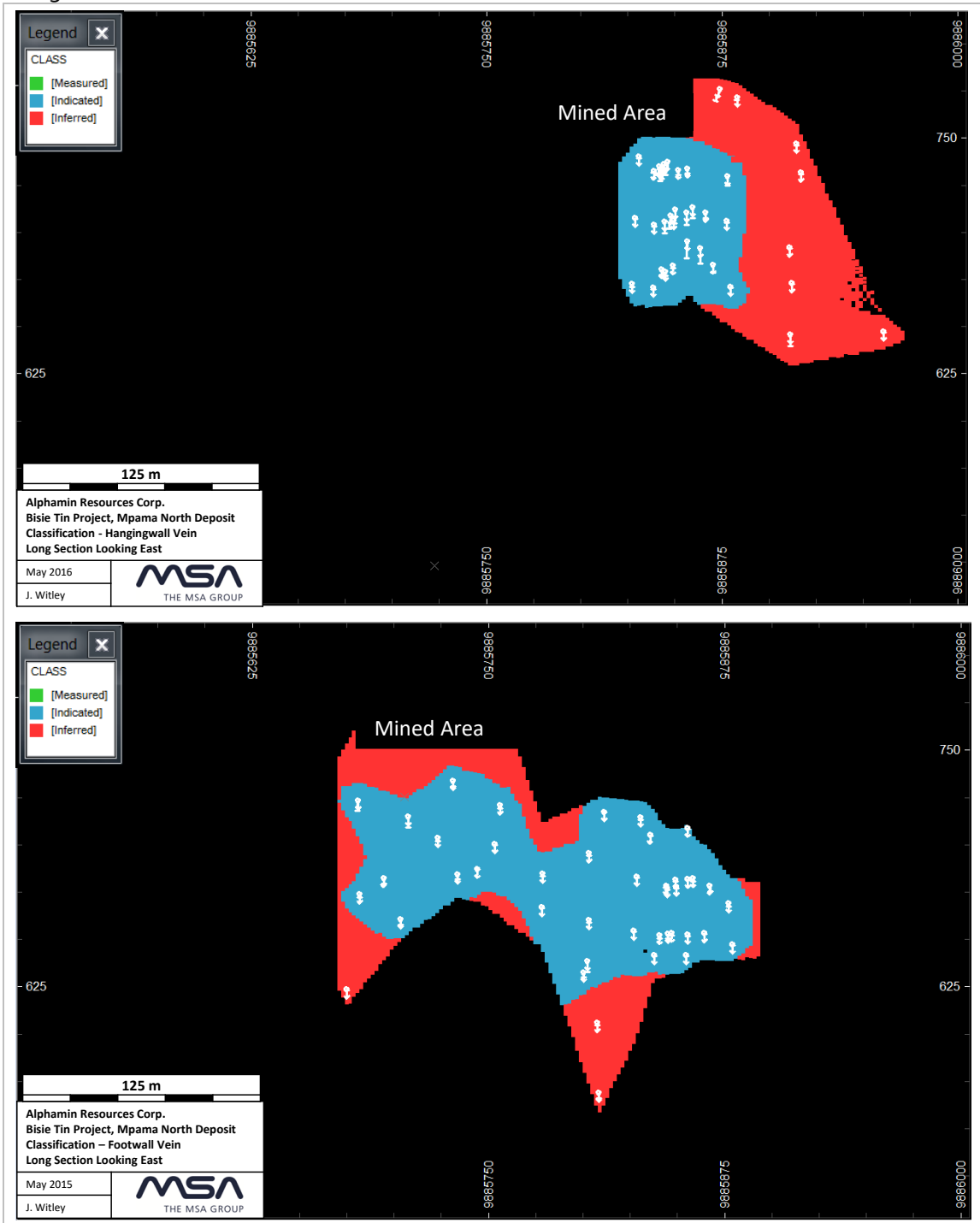

Drillhole intersections shown in white.

14.10 MINERAL RESOURCE STATEMENT

The Mineral Resource estimate has been completed by Mr. J.C. Witley (BSc Hons, MSc (Eng.)) who is a geologist with 28 years' experience in base and precious metals exploration and mining as well as Mineral Resource evaluation and reporting. He is a Principal Resource Consultant for The MSA Group (an independent consulting company), is a member in good standing with the South African Council for Natural Scientific Professions (SACNASP) and is a Fellow of the Geological Society of South Africa

(GSSA). Mr. Witley has the appropriate relevant qualifications and experience to be considered a “Qualified Person” for the style and type of mineralization and activity being undertaken as defined in National Instrument 43-101 Standards of Disclosure of Mineral Projects (NI 43-101).

The Mineral Resource estimate as at 09 May 2016 is presented in Table 14.16. The Mineral Resource is stated at a cut-off grade of 0.50% Sn. In the QP’s opinion, the Mineral Resources reported herein at the selected cut-off grade have “reasonable prospects for economic extraction”, taking into consideration mining and processing assumptions. These are based on an underground mine and concentrator with operating cost of US\$ 50 per tonne and a tin price of US\$ 20,000 per tonne. The high grade mineralization of reasonable tonnage leaves no doubts as to reasonable potential for economic extraction, it being one of the highest grade undeveloped tin deposits in the world. The reader is cautioned that the assessment of the mineralization estimate that is incorporated in the Mineral Resource is solely for the purpose of reporting Mineral Resources that have “reasonable prospects for economic extraction” underground and does not represent an attempt to estimate Mineral Reserves.

The Mineral Resource was estimated using The Canadian Institute of Mining, Metallurgy and Petroleum (CIM) Best Practice Guidelines (2003) and is reported in accordance with the 2014 CIM Definition Standards, which have been incorporated by reference into National Instrument 43-101 – Standards of Disclosure for Mineral Projects (NI 43-101). The Mineral Resource is classified into the Measured, Indicated and Inferred categories. All Mineral Resources are reported inclusive of Mineral Reserves.

Table 14.16 Bisie Mpama North Mineral Resource at 0.50 % Sn cut-off grade, 09 May 2016

Category	Tonnes (Millions)	Sn %	Sn tonnes (thousands)	Cu %	Zn %	Pb ppm	Ag g/t
Measured	0.46	4.31	19.6	0.22	0.12	0.007	1.4
Indicated	4.14	4.55	188.4	0.32	0.16	0.010	2.8
Total M&I	4.60	4.52	208.1	0.31	0.15	0.010	2.7
Inferred	0.54	4.25	22.8	0.16	0.09	0.013	1.4

Notes:

All tabulated data has been rounded and as a result minor computational errors may occur. Mineral Resources which are not Mineral Reserves have no demonstrated economic viability. The Mineral Resource is reported inclusive of Mineral Reserves.

Alphamin has an 80.25 per cent interest in the Bisie Project. The Gross Mineral Resource for the Project is reported.

The Mineral Resource estimate is shown by Vein zone and category in Table 14.17.

Table 14.17 Bisie Mpama North Mineral Resources by zone and category, at 0.50% Sn cut-off grade, 9 May 2016

Zone	Class	Tonnes (Millions)	Sn %	Sn tonnes (thousands)	Cu %	Zn %	Pb ppm	Ag g/t
Main Vein	Measured	0.46	4.31	19.6	0.22	0.12	0.007	1.4
Main Vein	Indicated	4.01	4.55	182.5	0.33	0.16	0.010	2.8
HW Vein	Measured	0.00	-	0.0	-	-	-	-
HW Vein	Indicated	0.05	2.58	1.3	0.03	0.12	0.006	0.2
FW Vein	Measured	0.00	-	0.0				
FW Vein	Indicated	0.08	5.52	4.6	0.12	0.08	0.009	1.8
Main Vein S1 Block	Measured	0.00	-	0.0	-	-	-	-
Main Vein S1 Block	Indicated	0.00	-	0.0	-	-	-	-
Total	Measured	0.46	4.31	19.6	0.22	0.12	0.007	1.4
Total	Indicated	4.14	4.55	188.4	0.32	0.16	0.010	2.8
Total	M&I	4.60	4.52	208.1	0.31	0.15	0.010	2.7
Main Vein	Inferred	0.39	4.45	17.4	0.16	0.11	0.016	1.5
HW Vein	Inferred	0.03	1.18	0.3	0.03	0.04	0.004	0.2
FW Vein	Inferred	0.04	2.64	1.2	0.14	0.07	0.006	2.0
Main Vein S1 Block	Inferred	0.07	5.48	3.9	0.27	0.03	0.002	1.1
Total	Inferred	0.54	4.25	22.8	0.16	0.09	0.013	1.4

Notes:

*All tabulated data has been rounded and as a result minor computational errors may occur
 Mineral Resources which are not Mineral Reserves have no demonstrated economic viability.
 The Mineral Resource is reported inclusive of Mineral Reserves.*

Alphamin has an 80.25 per cent interest in the Bisie Project. The Gross Mineral Resource for the Project is reported.

The Mineral Resource has been presented at a variety of cut-off grades as shown in Table 14.18 for the combined Measured and Indicated Mineral Resources and in Table 14.19 for the Inferred Mineral Resource.

Table 14.18 Bisie Mpama North Measured and Indicated Mineral Resources grade tonnage table, 09 May 2016

Cut-Off Sn %	Tonnes (Millions)	Sn %	Sn tonnes (thousands)	Cu %	Zn %	Pb ppm	Ag g/t
0.25	4.66	4.47	208.3	0.31	0.15	0.010	2.6
0.50	4.60	4.52	208.1	0.31	0.15	0.010	2.7
0.75	4.44	4.66	207.1	0.32	0.16	0.010	2.7
1.00	4.23	4.85	205.2	0.32	0.16	0.010	2.7
1.50	3.67	5.40	198.2	0.33	0.16	0.010	2.8
1.80	3.32	5.79	192.5	0.34	0.17	0.010	2.9
2.00	3.07	6.11	187.7	0.34	0.17	0.010	2.9

Notes:

All tabulated data has been rounded and as a result minor computational errors may occur
 Mineral Resources which are not Mineral Reserves have no demonstrated economic viability.
 The Mineral Resource is reported inclusive of Mineral Reserves.

Alphamin has an 80.25 per cent interest in the Bisie Project. The Gross Mineral Resource for the Project is reported.

Table 14.19 Bisie Mpama North Zone Inferred Mineral Resources grade tonnage table, 09 May 2016

Cut-Off Sn %	Tonnes (Millions)	Sn %	Sn tonnes (thousands)	Cu %	Zn %	Pb ppm	Ag g/t
0.25	0.55	4.17	22.9	0.16	0.09	0.012	1.4
0.50	0.54	4.25	22.8	0.16	0.09	0.013	1.4
0.75	0.51	4.40	22.7	0.17	0.09	0.013	1.5
1.00	0.48	4.63	22.4	0.17	0.10	0.013	1.5
1.50	0.38	5.58	21.1	0.19	0.10	0.014	1.6
1.80	0.35	5.94	20.6	0.19	0.11	0.015	1.6
2.00	0.33	6.21	20.2	0.19	0.11	0.014	1.6

Notes:

All tabulated data has been rounded and as a result minor computational errors may occur
 Mineral Resources which are not Mineral Reserves have no demonstrated economic viability.
 The Mineral Resource is reported inclusive of Mineral Reserves.

Alphamin has an 80.25 per cent interest in the Bisie Project. The Gross Mineral Resource for the Project is reported.

The Mineral Resource dips at approximately 65° to the east and strikes close to north-south. The mineralized zone plunges approximately 35° towards the north. The Mineral Resource estimate is limited to deeper than 50 m below surface in the areas where artisanal mining has taken place. The shallow area of Mpama North has been partially depleted by mining and the quantity of remaining Mineral Resource in the affected area cannot be stated within reasonable limits. The maximum depth of the Mineral Resource is dictated by the location of the diamond drilling data. The Mineral Resource

extends for approximately 700 m in the northerly plunge direction and 300 m in dip, and the deepest Mineral Resource reported is approximately 550 m below surface, the mineralization being open down-plunge.

The Main Vein zone of the Mineral Resource, which accounts for 97 % of the Mineral Resource, is on average approximately 9 m thick, although is narrower (less than 1 m) at the margins and up to 22 m thick in the central areas. The zones that occur several metres above and below the main zone are generally considerably narrower than the Main Vein zone and cover areas of between approximately 100 m and 220 m in the dip and strike directions.

14.11 COMPARISON WITH PREVIOUS ESTIMATES

This is the fourth reported Mineral Resource estimate for the Mpama North deposit at Bisie, the first estimate being effective 26 November 2013, the second 15 March 2015 and the third 15 October 2015. A comparison between the four estimates is shown in Table 14.20.

Table 14.20 Bisie Mpama North comparison between previous estimates and 09 May 2016 estimate at 0.50% Sn cut-off grade

Classification	09 May 2016			15 October 2015			15 March 2015			26 November 2013		
	Mt	Sn %	Sn (Kt)	Mt	Sn %	Sn (Kt)	Mt	Sn %	Sn (Kt)	Mt	Sn %	Sn (Kt)
Measured	0.46	4.31	19.6	0.00	-	0.0	0.00	-	0.0	0.00	-	0.0
Indicated	4.14	4.55	188.4	3.94	3.94	155.3	2.65	4.49	119.2	0.00	-	0.0
M&I	4.60	4.52	208.1	3.94	3.94	155.3	2.65	4.49	119.2	0.00	-	0.0
Inferred	0.54	4.25	22.8	0.84	4.64	38.9	1.20	3.60	42.8	4.00	3.50	141.0

Notes: Mt = Million tonnes, Kt = Thousand tonnes, M&I is the summation of Measured and Indicated.

All tabulated data has been rounded and as a result minor computational errors may occur.

The total Mineral Resource increased from October 2015 to May 2016 as a result of step-out drilling and higher grade mineralization being intersected in the north. Infill drilling allowed for more Indicated Mineral Resources and the declaration of Measured Mineral Resources following the removal of the high grade sample correction applied in October 2015 due to resolution of the assay QAQC issues.

14.12 ASSESSMENT OF REPORTING CRITERIA

The checklist in Table 14.21 of assessment and reporting criteria summarises the pertinent criteria for this Mineral Resource estimate in accordance with CIM guidelines and the QP's assessment and comment on the estimates.

Table 14.21 Checklist of reporting criteria

Drilling techniques	<p>All drillholes were diamond drill cored and drilled from surface (mostly NQ) at angles of between -60° and -75°. The drillholes were drilled from east to west along section lines spaced between approximately 25 m and 50 m apart.</p> <p>21 PQ sized holes from a metallurgical drilling campaign were included that were drilled in three clusters approximately 25 m apart.</p>
Logging	<p>All of the drillholes were geologically logged by qualified geologists. The logging is of an appropriate standard for grade estimation.</p>
Drill sample recovery	<p>Core recovery in the mineralized zones was observed to be very good and is on average greater than 95%. Five of the shallow drillholes intersected artisanal workings and so recovery of the high grade mineralization was poor and therefore the data from these holes were not used for grade estimation.</p>
Sampling methods	<p>Half core samples were collected continuously through the mineralized zones after being cut longitudinally in half using a diamond saw. Drillhole samples were taken at nominal 1 m intervals, which were adjusted to smaller intervals in order to target the vein zones. Lithological contacts were honoured during the sampling. The QP's observations indicated that the routine sampling was performed to a reasonable standard and is suitable for evaluation purposes.</p>
Quality of assay data and laboratory tests	<p>The assays were conducted at ALS Chemex in Johannesburg where samples were analysed for tin using fused disc ME-XRF05 conducted on a pressed pellet with 10% precision and an upper limit of 10,000 ppm. This was reduced to 5,000 ppm from 2014 onwards. Over limit samples were sent to Vancouver for ME-XRF10 which uses a Lithium Borate 50:50 flux with an upper detection limit of 60% and precision of 5%.</p> <p>ME-ICP61, HF, HNO₃, HCL04 and HCL leach with ICP-AES finish was used for 33 elements including base metals. ME-OG62, a four acid digestion, was used on ore grade samples for Pb, Zn, Cu & Ag.</p> <p>External quality assurance of the laboratory assays for the Alphamin samples was monitored. Blank samples, certified reference materials and duplicate samples were inserted with the field samples accounting for approximately 10% of the total sample set.</p> <p>The QAQC measures used by Alphamin revealed the following:</p> <ul style="list-style-type: none"> • The high grade CRM (31.42% Sn) assays by ALS prior to 2015 returned values approximately 8% higher than the certified mean value. 98 pulp rejects from this period of between 1.5% and 60% Sn were re-assayed by ALS in 2016 together with the high grade CRM. The 2016 assays correlated well with those prior to 2015 and the high grade CRM returned values within tolerance. Therefore the pre-2015 assays were accepted for estimation without modification. • The lower grade CRM assays (<2% Sn) indicated that the Sn and Cu assays were accurate and unbiased, consistently returning values within two standard deviations of the accepted CRM value. • The field duplicates confirmed the nuggetty nature of the tin mineralization. The majority of the duplicate assays were within 20% of the field sample. • Blank samples indicated that no significant contamination occurred.

<p>Verification of sampling and assaying</p>	<p>A selection of cores representative of the entire drilling programme at Mpama North have been visually verified during three site visits by the QP (July 2013, May 2014 and August 2015). The QP observed the mineralization in the cores and compared it with the assay results. It was found that the assays generally agreed with the observations made on the core.</p> <p>The QP took ten quarter core field duplicates for independent check assay in 2013, which confirmed the original sample assays within reasonable limits for this style of mineralization</p> <p>150 pulp duplicates were sent to SGS (Johannesburg) in 2013 for confirmation assay and a further 173 were assayed in 2015. In 2015, 99 pulp duplicates were sent to Set point (Johannesburg) for confirmation assays.</p> <ul style="list-style-type: none"> • The pulp duplicates assayed by SGS in 2013 showed excellent correlation with the ALS assays at both high and low grade ranges. • SGS assays were lower than ALS for grades above 20% for the 2014 data checked in 2015. SGS under-reported the grade of all the CRMs that were inserted. The high grade CRM was under assayed by approximately 5%. • SGS assays in 2016 in the < 5% Sn grade range confirmed the ALS assays. The SGS tin assays were significantly lower for the higher grades, however the titration method used by SGS results in a significantly low grade bias compared with the CRM <p>Set point assays were lower than ALS for grades above 10% for the 2014 data checked in 2015. Set Point tended to under-report the grades of the CRMs.</p>
<p>Location of data points</p>	<p>All except five of the Bisie surface drillhole collars used in the Mineral Resource estimate were surveyed by digital GPS. For those that were not surveyed, the hand-held GPS readings were used with the elevation being corrected to that of the LIDAR topographic survey.</p> <p>Down-hole surveys were completed for all of the holes drilled at Mpama North.</p>
<p>Tonnage factors (in situ bulk densities)</p>	<p>Specific gravity determinations were made for 2,698 drillhole samples using laboratory gas pycnometer. A regression formula of tin grade against specific gravity was developed that was applied to the samples that did not have direct SG measurements. The assigned specific gravity was interpolated into the block model using ordinary kriging.</p> <p>The laboratory pycnometry readings compared well with a number of SG measurements completed using the Archimedes principle of weight in air versus weight in water.</p>
<p>Data density and distribution</p>	<p>The holes were drilled from east to west along section lines spaced approximately 50 m to 60 m apart with infill drilling on 25 m to 30 m spaced sections in a portion of the shallower area. Along the section lines, the drillholes intersected the mineralization between approximately 25 m and 50 m apart in most of the Mineral Resource area.</p> <p>21 PQ sized holes from a metallurgical drilling campaign were included that were drilled in three clusters approximately 25 m apart. Within the clusters, the PQ holes were drilled approximately 5 m apart.</p> <p>In the Mineral Resource area, 122 NQ drillholes were used for the grade estimate. A number of holes intersected mineralization outside of the area currently defined as a Mineral Resource and five of the shallow drillholes intersected artisanal workings. The data from these holes were not used for grade estimation.</p>
<p>Database integrity</p>	<p>Data are stored in an Access database. The QP completed spot checks on the database and is confident that the Alphamin database is an accurate representation of the original data collected.</p>
<p>Dimensions</p>	<p>The area defined as a Mineral Resource extends approximately 700 m in the down-plunge direction. It extends for approximately 300 m in the plane of mineralization perpendicular to the plunge. The main zone of the Mineral Resource, which accounts for 97% of the Mineral Resource, is on average approximately 9 m thick, although is narrower (less than 1 m) at the margins and up to 20 m thick in the central areas.</p> <p>The zones that occur several metres above and below the main zone are considerably narrower than the main zone and cover areas of between 100 m and 200 m in the dip and strike directions.</p>

Geological interpretation	<p>The mineralized intersections in drill core are clearly discernible. The Mineral Resource is interpreted to occur as irregular tabular mineralized zones, dipping 65° to the east, containing several narrow veins, blocks and disseminations of cassiterite. The mineralized zones are hosted in chlorite schist that is the result of intense alteration and may originally have been a distinct stratigraphic interval.</p> <p>The main zone of the Mineral Resource is almost continuous for over 650 m although it has been affected by a number of faults causing local displacement. Several faults with throws in excess of 10 m have been modelled.</p> <ul style="list-style-type: none"> • The Main Vein mineralization consists of a number of uncorrelated cassiterite veins within pervasively chloritised schist. This zone generally occurs over thicknesses of between 2 m and 22 m with an average thickness of approximately 9 m. The Main Vein zone is generally the highest grade and most consistent overall. • Hanging Wall Vein mineralization occurs within partly chloritised schist and micaceous schist between 4 m and 20 m above the Main Vein. This zone of mineralization is generally between 0.5 m and 4 m wide and occurs in the central area of the deposit and tapers out northwards. The middling between the Hanging Wall Vein and the Main Vein decreases in areas and it is possible that this vein merges into the Main Vein in some parts of the deposit. • Footwall Vein (FW Vein) mineralization occurs within the micaceous schist and amphibolite schist between 2 m and 12 m below the Main Vein. This zone is restricted to the southern areas, is very narrow (<50 cm) and high grade in its most northern occurrences but thickens to the south to several metres. It is possible that this vein merges into the Main Vein in the some parts of the deposit. <p>A three dimensional wireframe model was created for the three zones of mineralization based on a grade threshold of 0.35% Sn. The Main Vein zone is the most consistent zone and occurs within a persistent chlorite schist. Narrower less continuous zones occur above and below the main zone within chlorite-mica schists.</p>
Domains	<p>The mineralization was modelled as three tabular zones containing irregular vein style mineralization. A hard boundary was used to select data for estimation in order to honour the sharp nature of vein boundaries.</p>
Compositing	<p>Sample lengths were composited to 1 m. Composites of less than 1 m occurred in the narrow vein areas, which were retained. Accumulations of Sn%-density-composite length were calculated for grade estimation so that narrow extremely high grade composites did not excessively influence the estimate.</p>
Statistics and variography	<p>Two populations of Sn mineralization occur, a high grade population of cassiterite veins and a lower grade population containing disseminated cassiterite as vein fragments and blebs. The data were separated into the two statistical populations, which resulted in the coefficient of variation for the Sn accumulation composites in the high grade population being 0.5 and for the lower grade population being 1.6. The histograms are positively skewed.</p> <p>Normal scores variograms were calculated in the plane of the mineralization, down-hole and across strike. Variogram ranges for the Sn accumulation in the main zone were modelled with ranges in the order of 75 m in the longest direction of continuity and 60 m in the second direction. Reliable variograms could not be produced for both the Hanging Wall or Footwall zones, and the Main Vein zone variogram was used to estimate these areas.</p>
Top or bottom cuts for grades	<p>Top cuts were applied to outlier values that were above breaks in the cumulative probability plot for metals other than Sn. The high grade Sn values occur as a statistically distinct population with a low coefficient of variation and no top-cuts were considered necessary, the high grade distribution being estimated separately, with a restricted search.</p>
Data clustering	<p>21 PQ sized holes from a metallurgical drilling campaign were included that were drilled in three close clusters approximately 25 m apart. Within the clusters the PQ holes were drilled approximately 5 m apart. Outside of the metallurgical sampling area the grid is approximately regular.</p>
Block size	<p>20 mN by 2 mE by 10 mRL three dimensional block models were used. The blocks were divided into sub-cells to better represent the interpreted mineralization extents. The blocks were rotated into the plane of mineralization prior to estimation.</p>

Grade estimation	<p>The accumulation of tin grade, density and composite length were estimated using ordinary kriging. Copper, lead, zinc, silver, arsenic and sulphur grades were estimated directly.</p> <p>The Sn%-density-composite length accumulations were divided into a high grade population (>80 %t/m) and a lower grade population (<80 %t/m). The probability of a block containing values above and below this threshold was estimated by indicator kriging. Outside of the indicator variogram range, estimates did not use the extreme high grades (>80 %tm) in order to reduce the influence of these values on estimates further away from them. The high and low grade populations were estimated separately using ordinary kriging and the block model grade was then assigned based on the estimated grade of the high and low grade and their proportion in each block.</p> <p>A minimum number of 4 and a maximum of 10 one metre composites were required for the high grade Sn-accumulation population. A minimum number of 8 and a maximum of 24 one metre composites were required for the lower grade Sn-accumulation population and other variables. Search distances and orientations were aligned with the variogram range and mineralized trends.</p> <p>Estimates were extrapolated for a maximum distance of 20 m up- or down-plunge from the nearest drillhole intersection. Extrapolation is minimal over most of the Mineral Resource as the up-and down dip limits have been well defined by the drilling.</p>
Resource classification	<p>Measured Mineral Resources were declared where the drillhole spacing is approximately 25 m and where the geological model has low variability. The mineralization was classified as Indicated Mineral Resources if block estimates occur within the 50 m drilling grid, so that all Indicated estimates are informed by samples within the variogram range. The remainder of the interpreted model within the sparser drilled area was classified as Inferred Mineral Resources with a maximum extrapolation from a drillhole of 20 m along plunge. The up-plunge extremity (S1 Block) is separated from the main area by a fault and the structural interpretation in this area is tenuous and it does not contain sufficient data to classify them as Indicated Mineral Resources. Consequently this area was classified as Inferred Mineral Resources.</p> <p>The high grade mineralization of reasonable tonnage leads no doubts as to reasonable potential for economic extraction, it being one of the highest grade undeveloped tin deposits in the world.</p>
Mining cuts	<p>The thickness of the mineralization was honoured in the estimate and as a result some areas will be more sensitive to dilution than others. The thickness, grade and steep dip implies that the Mineral Resource can be extracted using established underground mining methods.</p>
Metallurgical factors or assumptions	<p>The tin mineralization occurs as cassiterite, an oxide of tin (SnO₂). The Cu, Zn and Pb mineralization occurs as sulphides. Each of these minerals is amenable to standard processing techniques for each metal.</p> <p>The mineralization contains an average of 464 ppm arsenic which is unlikely to have a material deleterious effect.</p>
Legal aspects and tenure	<p>Alphamin Resources Corp, through its wholly owned DRC subsidiary, Alphamin Mining Bisie SA, has a Mining License PE 13155 which covers a portion of its 84.55% owned PR5266 and includes the Bisie Tin Prospect.</p>
Audits, reviews and site inspection	<p>The following review work was completed by the QP:</p> <ul style="list-style-type: none"> • Inspection of approximately 25% of the Alphamin cores used in the Mineral Resource estimate • Database spot check • Inspection of drill sites • Independent check sampling

15 MINERAL RESERVE ESTIMATES

15.1 CUT-OFF GRADE CALCULATION

The cut-off grade for Bisie has been calculated as follows.

Table 15.1 Cut-off grade calculation

	Units		Notes
Direct Mining Cost	USD/t	70.00	As per mining study
Processing cost	USD/t	12.26	As per client calculation
Labour cost	USD/t	16.39	As per client calculation
Tailings cost	USD/t	8.89	As per client calculation
G&A cost	USD/t	42.15	As per client calculation
Freight & treatment cost	USD/t	30.00	As per client calculation
Total operating cost	USD/t	179.69	Calculated
Market tin price	USD/t Sn	21 000	Current market price
Royalties	USD/t Sn	420.00	2% of gross revenue
Realised tin price on-mine	USD/t Sn	20 580	
Plant recovery	%	73	As per Process Test work
Shut-off grade at draw-point	%	1.20	Sn
Cave recovery factor	%	90	Assumed
Geological factor	%	95	Assumed
In-situ pay limit grade	%	1.40	Sn

15.2 RESOURCES CONSIDERED FOR MINING

A sub-level caving (SLC) mining method has been selected for the extraction of the Bisie ore body and based on this method a mining cut-off grade of 1.40% Sn was calculated as per Table 15.1. This cut off was applied to the Measured and Indicated Mineral Resources to determine the volume of mineral resources that would be payable based on the cut off calculation assumptions.

15.3 MODIFYING FACTORS

The modifying factors applied to convert the Mineral Resource estimate to Mineral Reserve is based on the SLC mining method. Stope designs as outlined in 16.5.3 of this document were applied to the Mineral Resources above the cut-off grade. The modifying factors applied are as follows:

- Cut-off grade – 1.40% Sn
- Ore Recovery – 85%.
- Planned Dilution – 14.5%

- Unplanned Dilution – 35%

15.4 PROJECT VIABILITY

In order to declare Mineral Reserves it is required to demonstrate that the project is viable when only Measured and Indicated Mineral Resources are included in the mine plan and financial evaluation. A financial model was developed to evaluate the technical and economic issues relevant to the project. A summary of the technical and economic parameters used in determining the financial model as well as the main results of the model are shown below in the table below. The results of this model are not necessarily the same as reported under section 22 of this report as the input factors and assumptions used are different.

Table 15.2 Demonstration of project viability for declaring Mineral Reserves

Production		
Production rate	376	ktpa
Tonnes mined	4.67	million tonnes
Life of mine (LOM)	12	years
Tin produced	122,127	tonnes
Process plant recovery	73	%
Capital Cost		
Total Capital Cost	165.72	USD million
Capital Intensity	1,357	USD/t Sn
Operating Cost		
Total Mine Gate Operating Cost (LOM)	737.6	USD million
Mine Gate Operating Cost (LOM Avg.)	158	USD/t milled
Mine Gate Operating Cost (LOM Avg.)	6,040	USD/t Sn
Total Operating Cost (LOM)	1,142.3	USD million
Total Operating Cost (LOM Avg.)	244.5	USD/t milled
Total Operating Cost (LOM Avg.)	9,353	USD/t Sn
Tax and Royalty		
Corporation Tax Paid	246.5	USD million
Royalty Paid	39.8	USD million
Total Revenue		
Tin (Sn) Price	17,300	USD/t Sn
Total Revenue (LOM)	2,112.8	USD million
Financial Metrics		
EBITDA	970.5	USD million
Gross Cashflow	804.8	USD million

Net Cashflow	518.6	USD million
Post-Tax NPV (@ 8%)	402.2	USD million
Post-Tax IRR	49.1	%
Operating Margin	45.9	%
Payback Period	17	months
Peak Funding Requirement	149.44	USD million

15.5 MINERAL RESERVE STATEMENT

The Mineral Reserve statement for Mpama North is given as follows.

Table 15.3 Mineral Reserves for Mpama North at 1.4%Sn cut-off grade

Classification	Tonnes (millions)	Tin (%)	Tin tonnes (thousands)
Proven	0.38	4.17	15.9
Probable	4.29	3.53	151.4
Total Proven and Probable	4.67	3.58	167.3

Notes:

- The reserves were based on applying the Datamine Mineable Shape Optimizer (MSO) software that determines stope shapes that are economical based on the applied cut-off grade and mining parameters.*
- The Bisie orebody contains areas where the dip of the ore footwall is less than the standard 70° normally required for the method. In these areas, the footwall mining drive and a portion of the stope ring was placed partially in the waste footwall as long as the MSO reading remained economic. This waste reports as planned dilution.*
- The waste dilution entering the run of mine ore stream from the drawpoints during extraction of the blasted stope rings has been termed unplanned dilution. It is generally experienced in standard SLC that the dilution is $\pm 35\%$ for an ore recovery of 85%.*
- The general level of ore loss experienced in the cave area in longitudinal SLC is $\pm 15\%$.*
- A delayed draw SLC extraction methodology was applied to the top 3 sub levels of the mining layout to cater for potential air blasts if the caving process is delayed. The delayed draw application establishes an ore blanket or cushion above and behind the rings being blasted to protect the drawpoints being drawn. The methodology entails limiting draw of the blasted rings to 30% on the top level, 50% on the 2nd level and 90% on the 3rd level. On the assumption that general caving has been established by the time the 4th level mining commences the ore cushion can be drawn to a normal SLC cut off. The dilution in this process is considerably less and was nominally estimated at 10% ore with recovery, assuming the ore cushion is drawn on the 4th level estimated at 90% for the 4 levels combined.*

No Inferred Mineral Resources have been included in the estimation of Mineral Reserves.

16 MINING METHODS

16.1 GEOLOGY AND RESOURCES

16.2 GEOTECHNICAL CHARACTERISATION AND DESIGN

The geotechnical evaluation of the Bisie Project area consisted of two elements:

- Geotechnical data acquisition:
 - Logging of core at site.
 - Selection of core samples at site.
 - Geotechnical testwork of selected samples at a laboratory in Johannesburg.
 - Transformation of raw data into geotechnical design criteria.
- Geotechnical design:
 - Portal design.
 - Determination of maximum spans for all excavations.
 - Determination of minimum standoff distances for placement of footwall infrastructure.
 - Determination of support requirements for all excavations.
 - Determination of caving characteristics for the sub-level caving (SLC) mining method selected.

16.2.1 Geotechnical Data Acquisition

The geotechnical data acquisition program commenced at a concept level of accuracy in May 2014, with the logging of un-orientated core from 5 boreholes. The database was later supplemented with information collected from 7 resource holes in November / December 2014. Six (6) portal holes were logged geotechnically in April / May 2015. The information collected allowed for a comprehensive assessment of the geotechnical character of the orebody and surrounding rock mass. The data collected for this study was viewed as being sufficient to produce geotechnical design characteristics at a DFS level of accuracy. Geotechnical data acquisition addressed the following issues:

- The geological setting of the orebody;
- The geohydrological and seismic conditions based on literature studies;
- Rock mass quality indicators based on the widely accepted Rock Mass Rating and Q Index systems;
- Analysis of discontinuity orientations and frequencies in the orebody and surrounding rock mass;
- Intact rock strength estimates for samples selected from boreholes which includes uniaxial and triaxial estimates;
- Derivation of mechanical properties of intact rock as well as joints.
- Derivation of field estimates of rockmass properties.

16.2.1.1 Geotechnical setting

Data collected during the logging phase revealed that the major rock types encountered in the Bisie project area are schists of varying degrees of alteration. Three (3) basic rock types were delineated for the Bisie Tin project area, namely, chloritised schist, amphibolite schist and mica schist. Witley and Heins (2014) in their competent persons report (CPR) described the host rock and mineralised zones as follows:

“The tin mineralization found so far at the Bisie Project is confined to the north-south striking, easterly dipping metasediments that occur approximately 3 km east of a granite contact. Structural and mineralogical evidence suggests that the cassiterite was emplaced first, followed by copper in the form of chalcopyrite and bornite, then by lead and zinc mineralization. Chlorite alteration is extensive in parts and is thought to be the result of late stage fluids entering the system. The tin and copper mineralization is predominantly found in zones dominated by intense chloritic alteration, although mineralized zones with no chlorite have also been intersected by drill holes. The host rocks are predominantly highly chlorite-altered amphibolites, fine- to medium-grained chlorite schists and to a lesser extent, the adjacent biotite schists and quartz schists”.

Jackson (2015) in his structural analysis described the deposit as follows:

“The Mpama North orebody comprises a sheeted set of cassiterite veins, 2mm to 1.8m thick, over a true width of 5m to 15m which form a tabular body striking north-south for 570m and dipping 50° to 65° to the east. The veins are hosted within an intensely chlorite altered amphibolite schist, approximately the same width as the orebody. The amphibolite is in turn hosted within a mica schist unit. A 2m to 3m wide chlorite schist halo commonly occurs along the contact between the amphibolite and mica schist”.

The conclusions drawn from the geological interpretation is that the deposit is highly altered and contains high quantities of chlorite.

16.2.1.2 Rock mass quality

The overall rock mass quality across the project area is classified as “good” based on the RMR89 and Q Index systems. Note: the classification as good represents rockmass quality before adjustments. A summary of rock mass quality is presented in the Figures and Table below.

Figure 16.1: Rock Mass Rating for all rock types

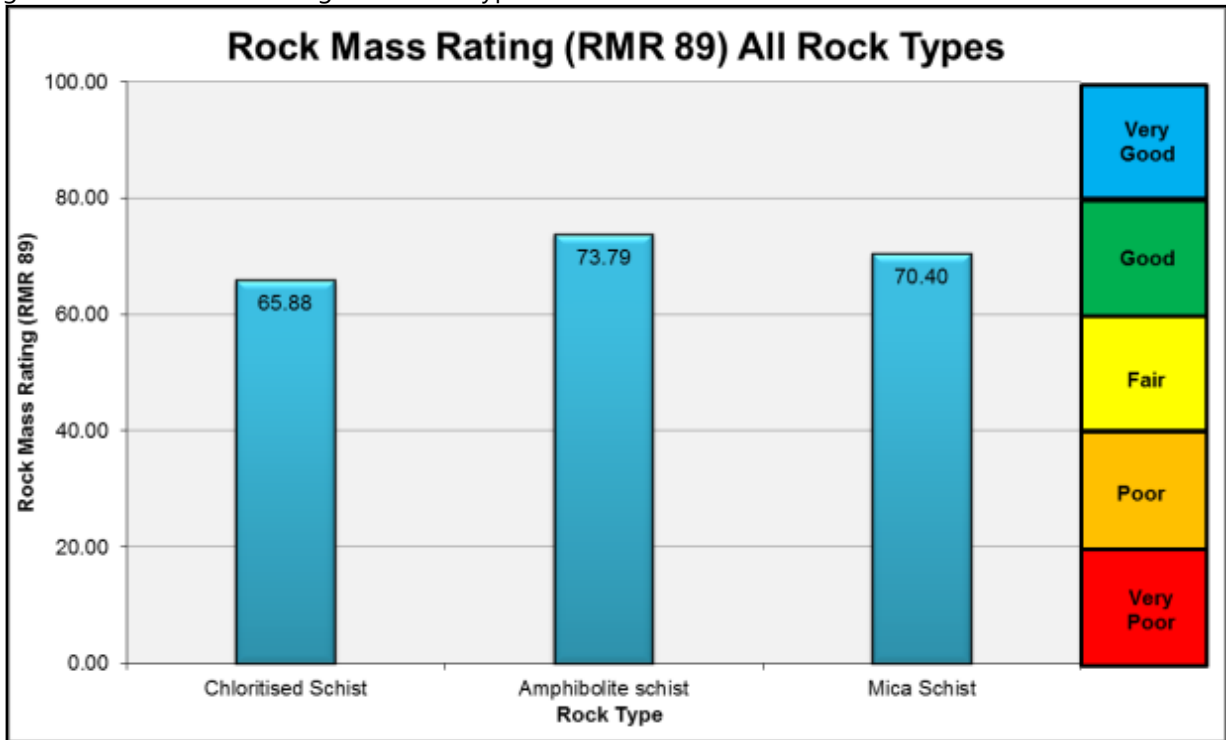

Figure 16.2: Q-Index for all rock types

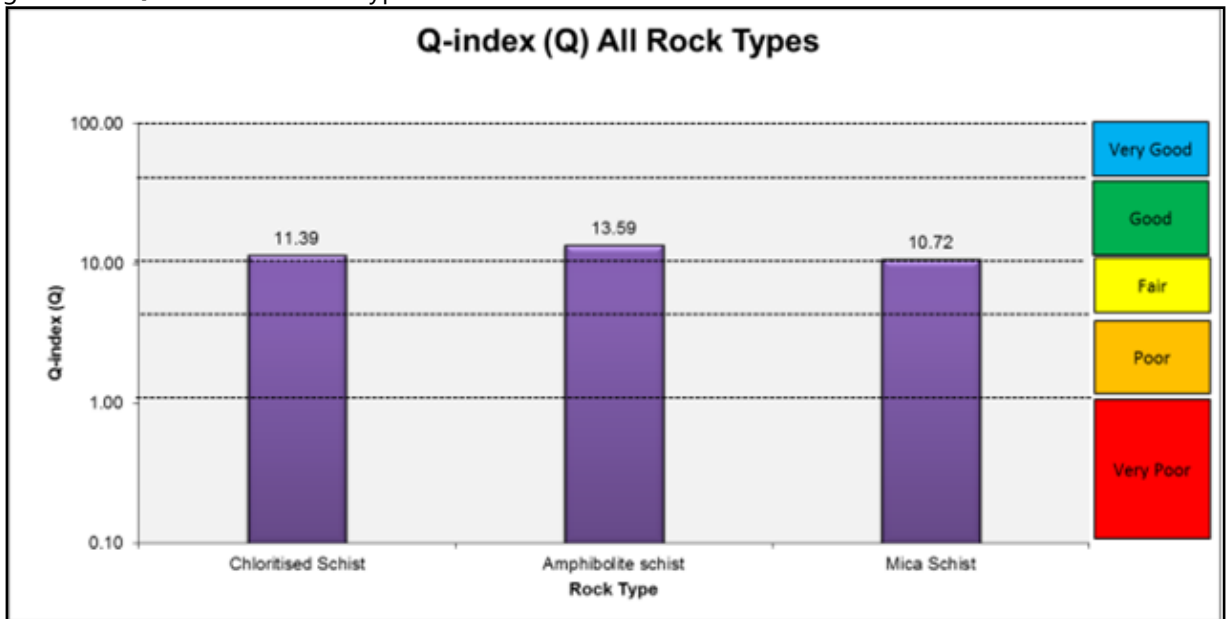

Table 16.1 Summary of rock mass quality data

Rock Type	RMR ₈₉		Q	
	Average	Interpretation	Average	Interpretation
Chloritised schist	65.88	Good	11.39	Good
Amphibolite schist	73.79	Good	13.59	Good
Mica schist	70.40	Good	10.72	Good

16.2.1.3 Joint orientations

The stereonet analysis using the DIPS software package indicated the presence of three (3) dominant joint sets each per rock type and numerous randomly orientated joints that could not be classified as a set. The orientations of the dominant joint sets are summarised in the table below.

Table 16.2 Summary of joint orientation data

Rock type	Dip (°)	Azimuth (°)	Joint Set
Chloritised Schist	63	106	JS 1
	63	84	JS 2
	60	54	JS 3
Amphibolite Schist	51	39	JS 1
	61	90	JS 2
	33	193	JS 3
Mica Schist	60	52	JS 1
	64	79	JS 2
	62	104	JS 3

16.2.1.4 Intact rock strength testing

UCS (uniaxial compressive strength) tests were carried out on rock samples selected from the boreholes logged on site. The results of these tests have been summarised in the Table below, showing failure strength properties, Young's Modulus and Poisson's ratio for the three (3) rock types. Chloritised schist and Mica schist exhibit strength values that were lower than anticipated. This can be attributable to the presence of the foliations as well as the altered properties (infill and alteration) of the rock. Results obtained from TCS (Triaxial compressive strength) tests further corroborates that the strength data is correct as the projected UCS using triaxial test data negates the effect of foliation.

Table 16.3 Summary of rock strength test results

Domain		Strength UCS (Mpa)	Tangent Elastic Modulus @ 50% UCS Gpa	Secant Elastic Modulus @ 50% UCS Gpa	Poisson's Ratio Tangent @ 50% UCS	Poisson's Ratio Secant @ 50% UCS
Chloritised schist	Average	35.05	15.72	11.87	0.36	0.19
	Minimum	22.60	10.90	8.67	0.10	0.07
	Maximum	41.92	18.50	14.40	0.52	0.30
	Standard Deviation	8.19	3.41	2.21	0.17	0.09
Amphibolite schist	Average	73.34	39.73	47.76	0.35	0.27
	Minimum	65.96	21.40	27.40	0.22	0.21
	Maximum	81.84	61.70	69.30	0.47	0.32
	Standard Deviation	5.17	15.98	14.67	0.09	0.04
Mica schist	Average	53.05	28.05	23.07	0.34	0.20
	Minimum	29.87	21.50	14.20	0.21	0.12
	Maximum	83.33	37.00	29.60	0.59	0.32
	Standard Deviation	21.28	6.91	5.08	0.16	0.09

16.2.1.5 Derivation of mechanical properties for intact rock and joints

The results from triaxial tests, UCS tests and data gathered during the geotechnical logging phase were analysed using the *RocData* program from the RocScience suite. The Hoek-Brown and Mohr-Coulomb parameters for intact rock and joints are summarised in the following two tables.

Table 16.4 Summary of Hoek-Brown and Mohr-Coulomb Parameters

	Hoek – Brown parameters			Mohr-Coulomb parameters	
	m_b	s	a	c (MPa)	ϕ (°)
Chloritised Schist	0.315	0.0057	0.502	12.00	23.54
Amphibolite Schist	0.969	0.0129	0.501	18.00	37.38
Mica Schist	0.389	0.0066	0.502	15.00	29.33

16.2.1.6 Regional stresses and rock strengths

In the absence of stress measurements, a benchmarking exercise was performed to derive the likely k-ratio (horizontal to vertical pre-mining stress ratio) that may exist for the depth of mining at the Bisie Project. The average ($k= 1.6$) of five reported k-ratios (Brown, 1980, Sheorey, 1983, Stacey, 1994) between 80-500 mbs for the African region was selected for Bisie (see Figure below). For geotechnical assessments of cavability using SLC, the three dominant rock domains (Amphibolite, Mica and Chlorite schists) are examined since any one or a combination could form the wall rock of SLC stopes.

Irrespective of the type of schist, the intense chlorite alteration defines the rock strength class as weak to medium strong.

Figure 16.3: Africa Region k-Ratios

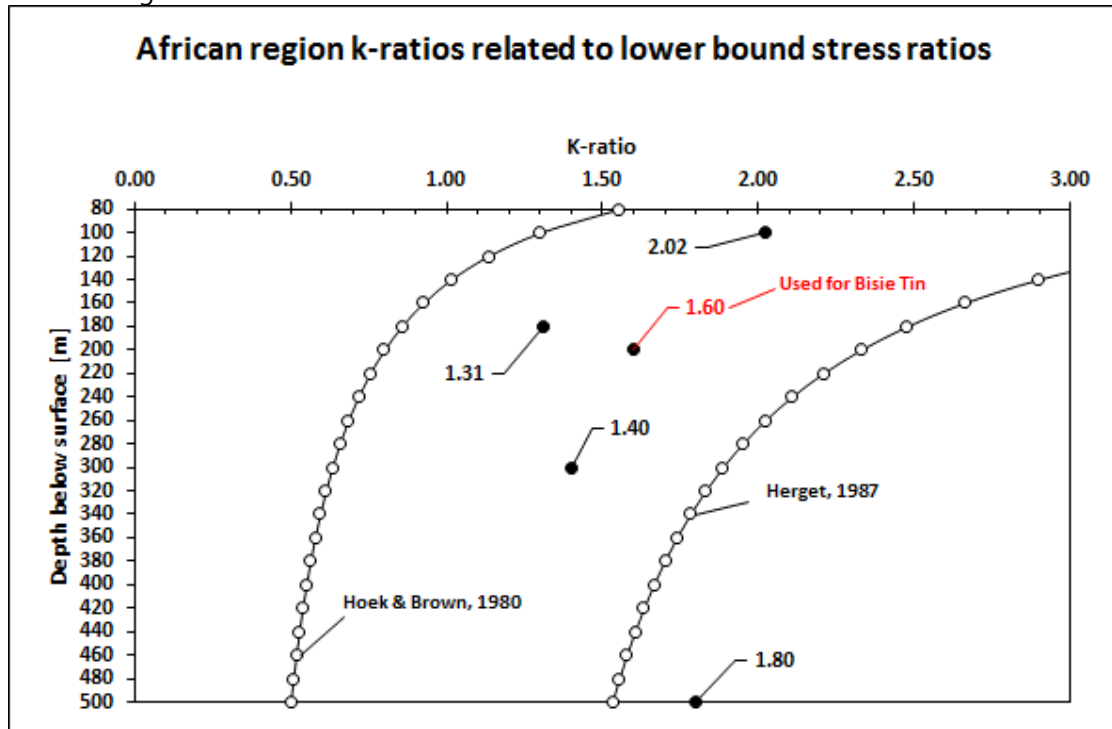

From an intact strength perspective, the rock can be classified as medium strong to strong as described previously and shown in the Table below. The rock mass (RBS) and design rock mass strengths (DRMS) classifies the rock mass as weak (see Table below). Within the context of underground mining between depths of 100 to 500 mbs, strengths in the range 35-50 MPa are considered low and easily susceptible to failure.

Table 16.5 Summary of intact rock strength

Statistics	Chloritised Schist [MPa]		Amphibolite Schist [MPa]		Mica Schist [MPa]	
	UCS tests	Triaxial tests	UCS tests	Triaxial tests	UCS tests	Triaxial tests
Mean	35.05	26.00	73.34	66.00	53.05	39.54
Standard deviation	8.19	NA	5.17	NA	21.28	NA
Minimum	22.60		65.96		29.87	
Maximum	41.92		81.84		83.33	

Table 16.6 Rock block, rock mass and design rock mass strength

Rock type	IRMR	UCS	Rock Block strength (RBS)	Rating	Rock mass strength (RMS)	Weathering adjustment	Orientation adjustment	Blasting adjustment	DRMS	(DRMS/RBS) %
Chlorite schist	43.83	35.00	28.00	4.00	11.15	0.80	0.90	0.94	7.55	26.96
Amphibolite schist	53.90	73.00	58.40	6.00	27.97	0.80	0.90	0.94	18.93	32.42
Mica Schist	48.96	53.00	42.40	6.00	18.22	0.80	0.90	0.94	12.33	29.08
MEAN	48.90	53.67	42.93	5.33	19.11	0.80	0.90	0.94	12.94	29.48

16.2.2 Portal Slope Engineering

Access to the underground mine will be through an adit, there will also be a second adit for return air. The use of adits to access the mine requires the design of portal areas. A boxcut will be excavated to allow portal access. The boxcut excavation will be in softs and is not expected to require drill and blasting, all excavation being mechanical. The depth of softs and completely weathered material is considerable and it is expected that ground competent enough to excavate the decline portal will only be found 7m to 10m below ground surface, and the floor of the decline adit will then be 5 m below this. This will result in a boxcut excavation that extends in weak softs a considerable distance up the hillside above the portal location.

The boxcut design will comprise:

- Overall slope angles in softs of not more than 30 degrees.
- Cut the boxcut in 10 m benches, with slopes battered back at 45 degrees and a 3 m berm left on each bench elevation.
- 6m spiling bars grouted as soil nails on a 2m X 2m grid spacing protected with wire mesh and 75mm shotcrete

Figure 16.4: Boxcut slope profile

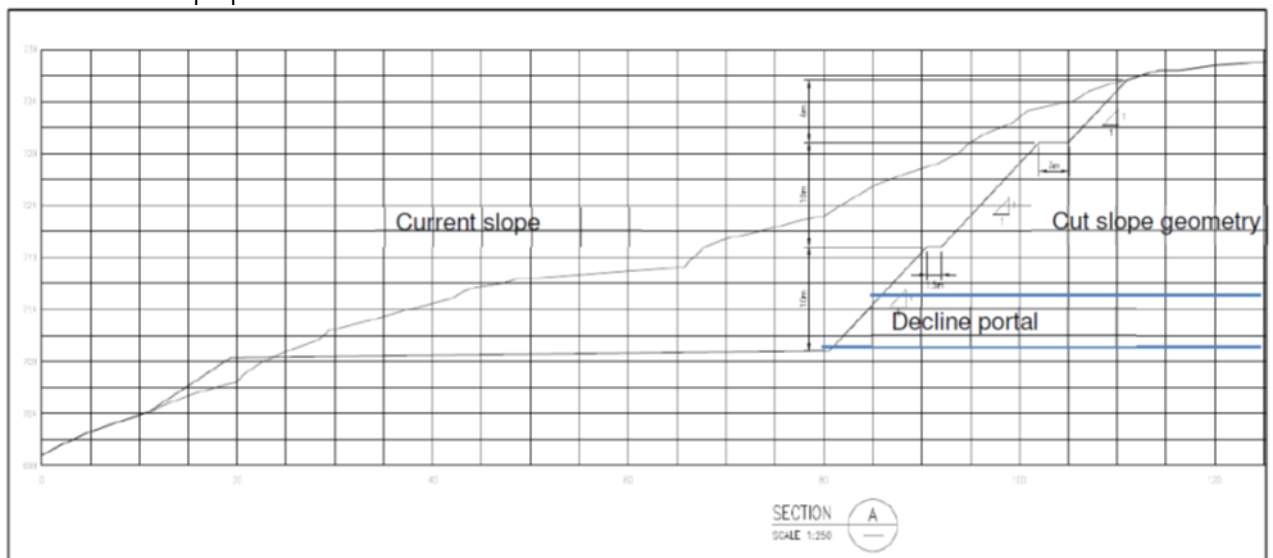

From the boxcut highwall cut slope, Mining requires a 4m x 4.8 m sized decline adit including space for a concrete floor for the required 18 m² internal cross sectional area after completion. Arched shape sets with circular crown will be used in the portal with an internal size of 4.8 m high by 4.2 m wide.

The portal support will include spiling, mesh, bolting and shotcrete, as per the following:

- Spiling into the high wall face of the box-cut should comprise two rows of twenty-five 6 m long fully grouted self-drilling spiling bars installed around the arch. The first row will be spaced 0.3 m on the portal perimeter, the second row will be 0.5 m and be 1 m out from the first row, above the portal brow. These spiling bars will be drilled ahead of the face and outwards/upwards at approximately 10 degrees from the centre line direction.
- Mesh of 100 mm aperture suspended and pinned to the brow. The method of pinning will include 1.5 m bolts or split sets, or soil nails, depending on the ground in the brow.
- 150 mm fibre reinforced shotcrete will extend over the brow and up the box-cut face above the portal.
- Steel arch T-H Type U-channel, 29 kg/m will be installed immediately inside the brow to form part of the support down the adit.
- A 300 mm thick weld mesh reinforced concrete floor of 25 MPa concrete will be placed after the sets are erected, and assists in providing bracing across the portal between the legs of the sets..

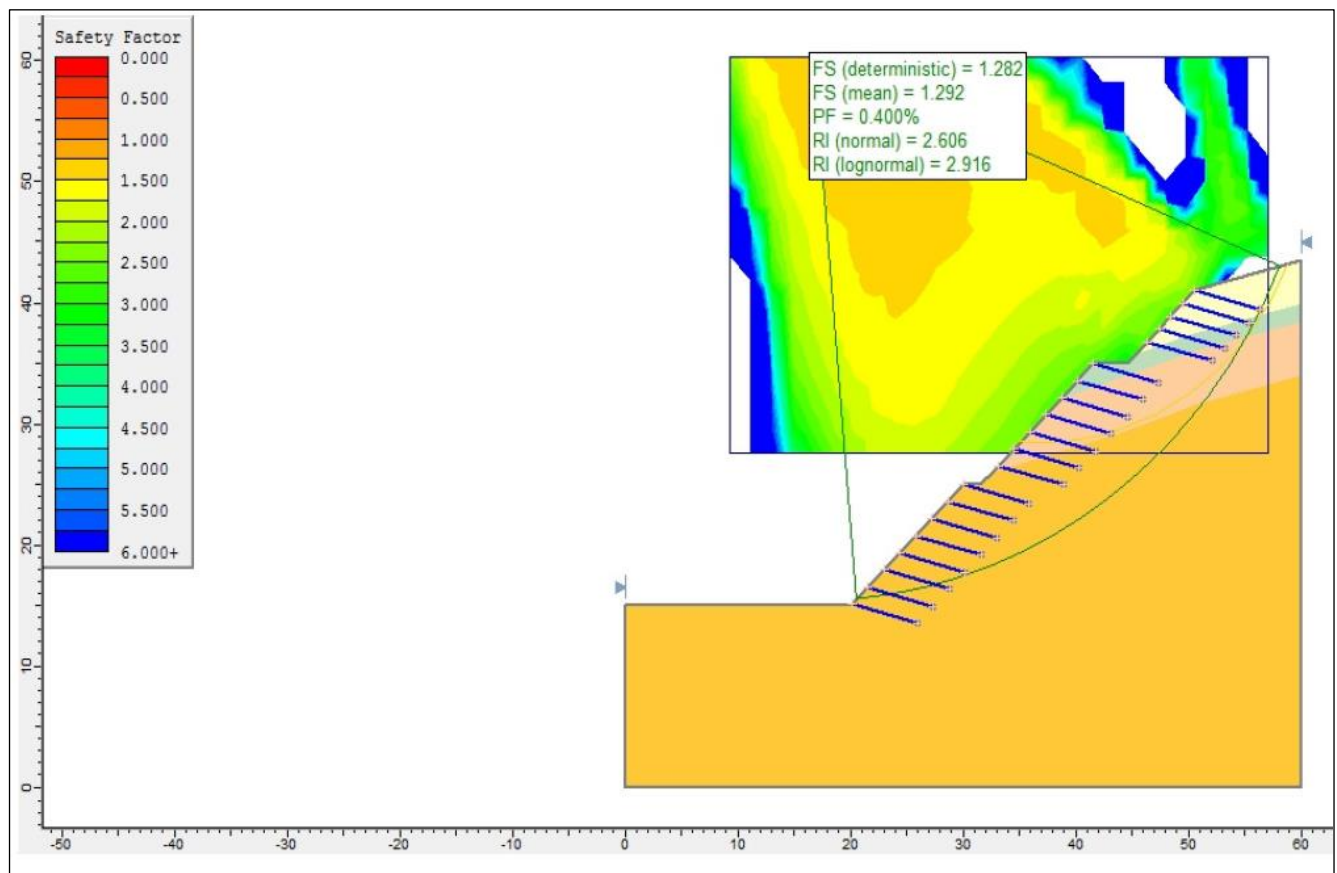

Figure 16.5: Boxcut profile with spiling bar support

The final boxcut configurations and required support standards (not drawn to scale), are presented in the Figure below.

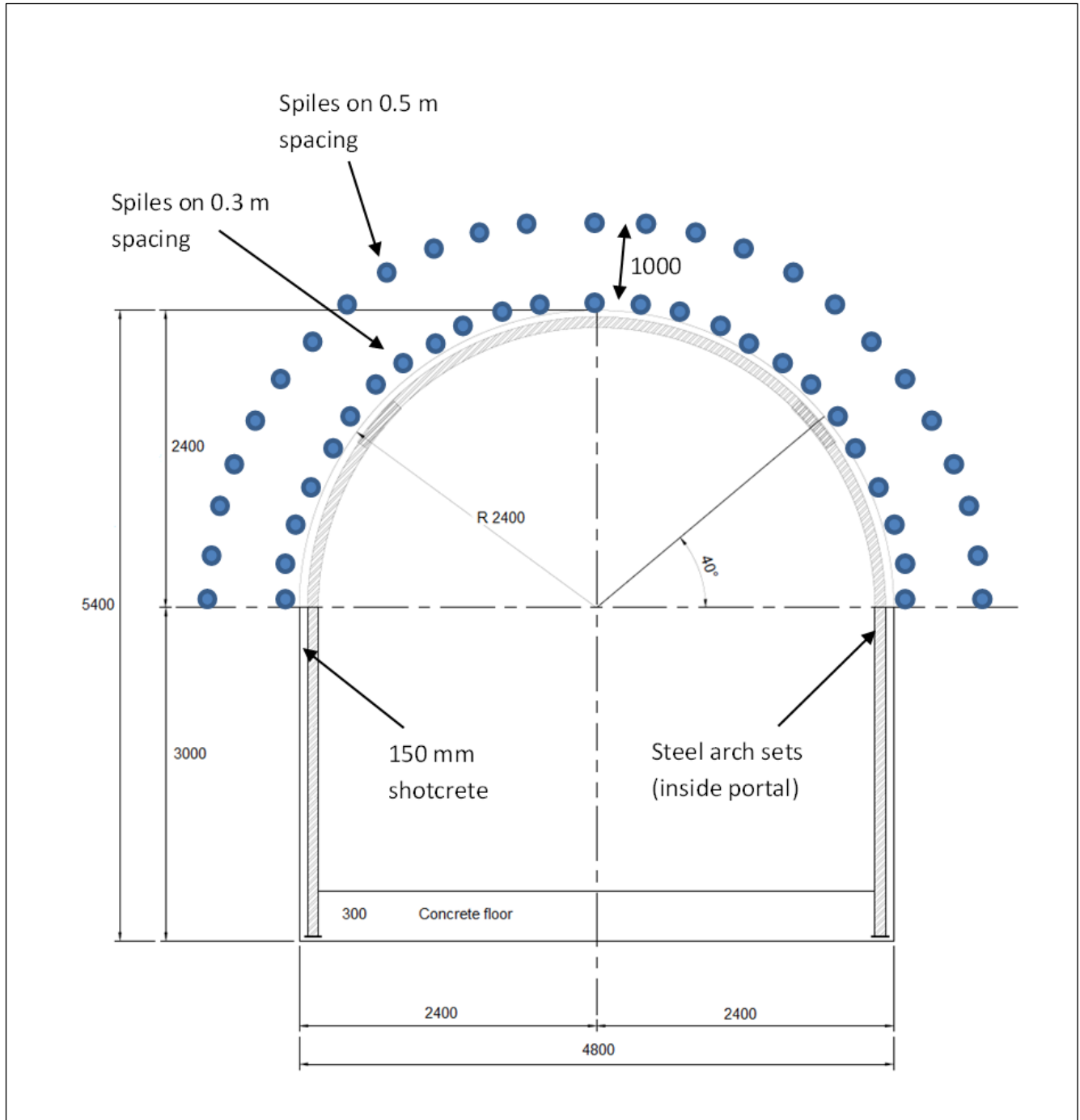
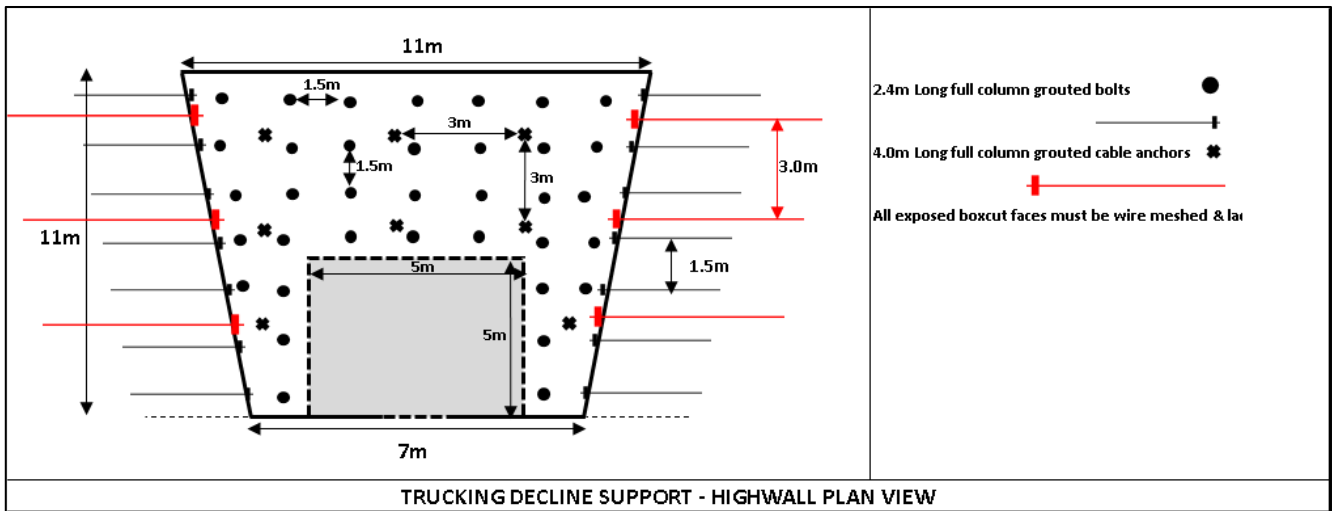
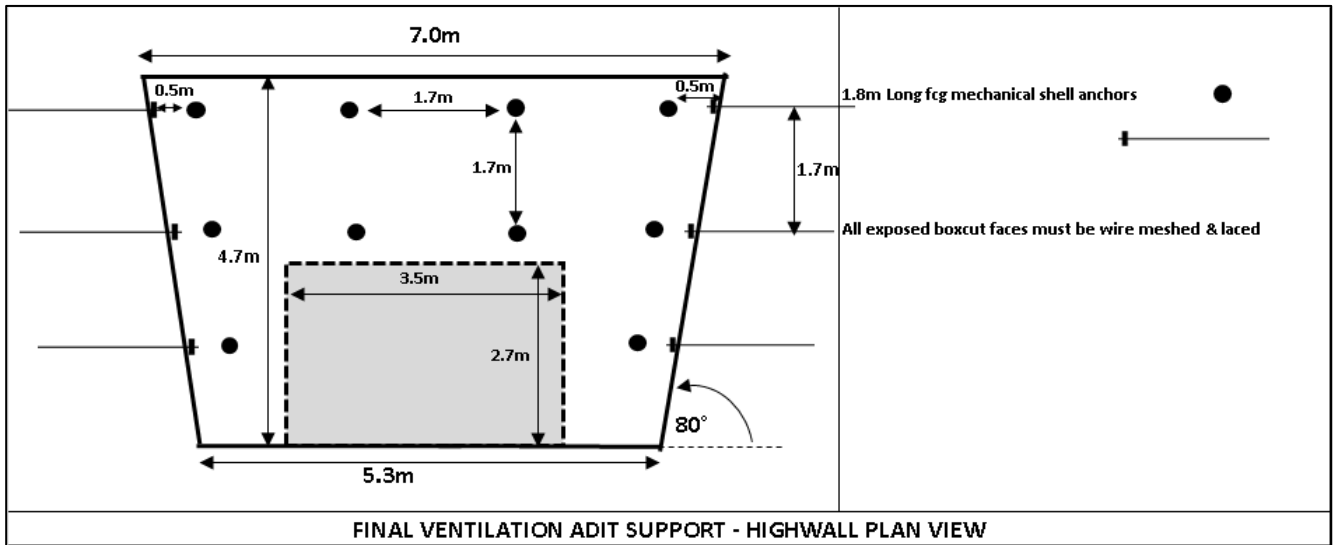

Figure 16.6: Trucking Decline Portal – Cross Section



From the portal into the hillside, the adit will be excavated in weathered mica schist. The distance of potentially very severe weathering with weak clay zones is 50 m along the length of the adit, from the boxcut highwall. In this weathered ground, support will be required up to the face, and the unsupported distance will need to be kept to a minimum of 1.8m for the sets

The adit support for the first 50m will include spiling, shotcrete and steel arches, in the worst ground, changing to shotcrete and bolting when ground improves, as per the following:

First 50 m:

- 150 mm polypropylene fibre reinforced shotcrete, 30 MPa strength. This will be applied up to the face after each round.
- Repeat spiling – further spiling comprising a row of twenty-five 6 m long fully grouted self-drilling spiling bars will be installed every 4 m along the portal crosscut. These will be installed on a 0.3 m spacing around the arched hangingwall perimeter, drilled ahead of the face and outwards/upwards at approximately 10 degrees from the centre line direction. The additional 30 cm allowed for support around this excavation will allow adequate space for installation of spiles and no additional excavation should be required where these are installed.
- Arch sets, T-H type U-channel, 29 kg/m, installed on 1.2 m centres with cross-bracing.

- 300 mm weld mesh reinforced concrete floor. 25 MPa concrete. Mesh would have 200 x 200 mm apertures and made from 8 to 10 mm welded wire.

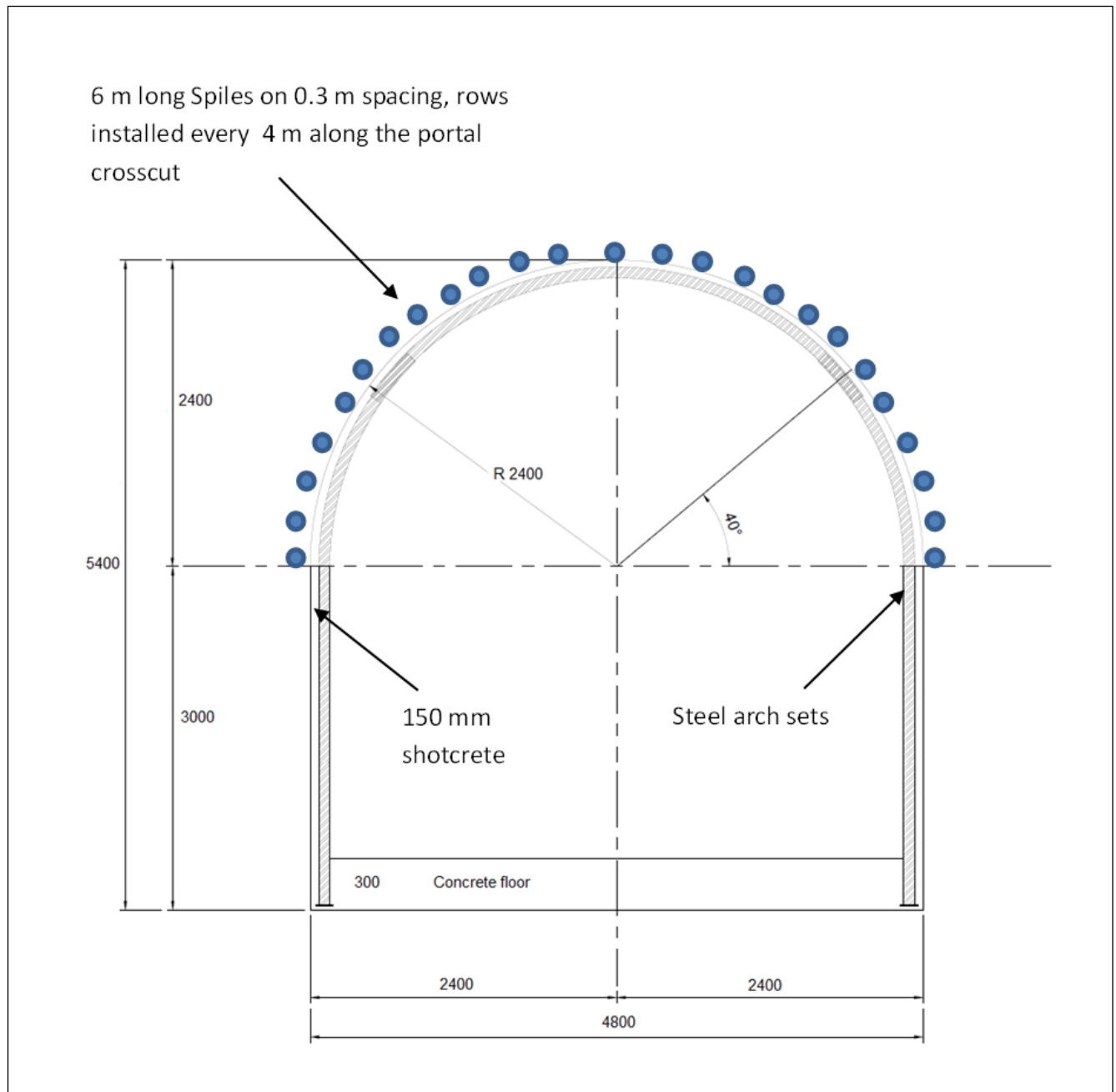

Figure 16.7: Trucking Decline Portal – Cross Section First 50m

Beyond 50 m if ground conditions permit (increased rock mass strength, and no further clay zones)

- 150 mm polypropylene fibre reinforced shotcrete, with 30 MPa strength. This will be applied up to the face after each round.
- 300 mm graded rock roadway.
- Rings of 11 x 2.0 m long, 16 mm diameter, resin bolts on a 1 m spaced pattern. Rings spaced 1 m apart along the adit. All bolts with 150 mm washers.

- Shotcrete thickness can be decreased to 50 mm when consistently fresh ground is encountered.

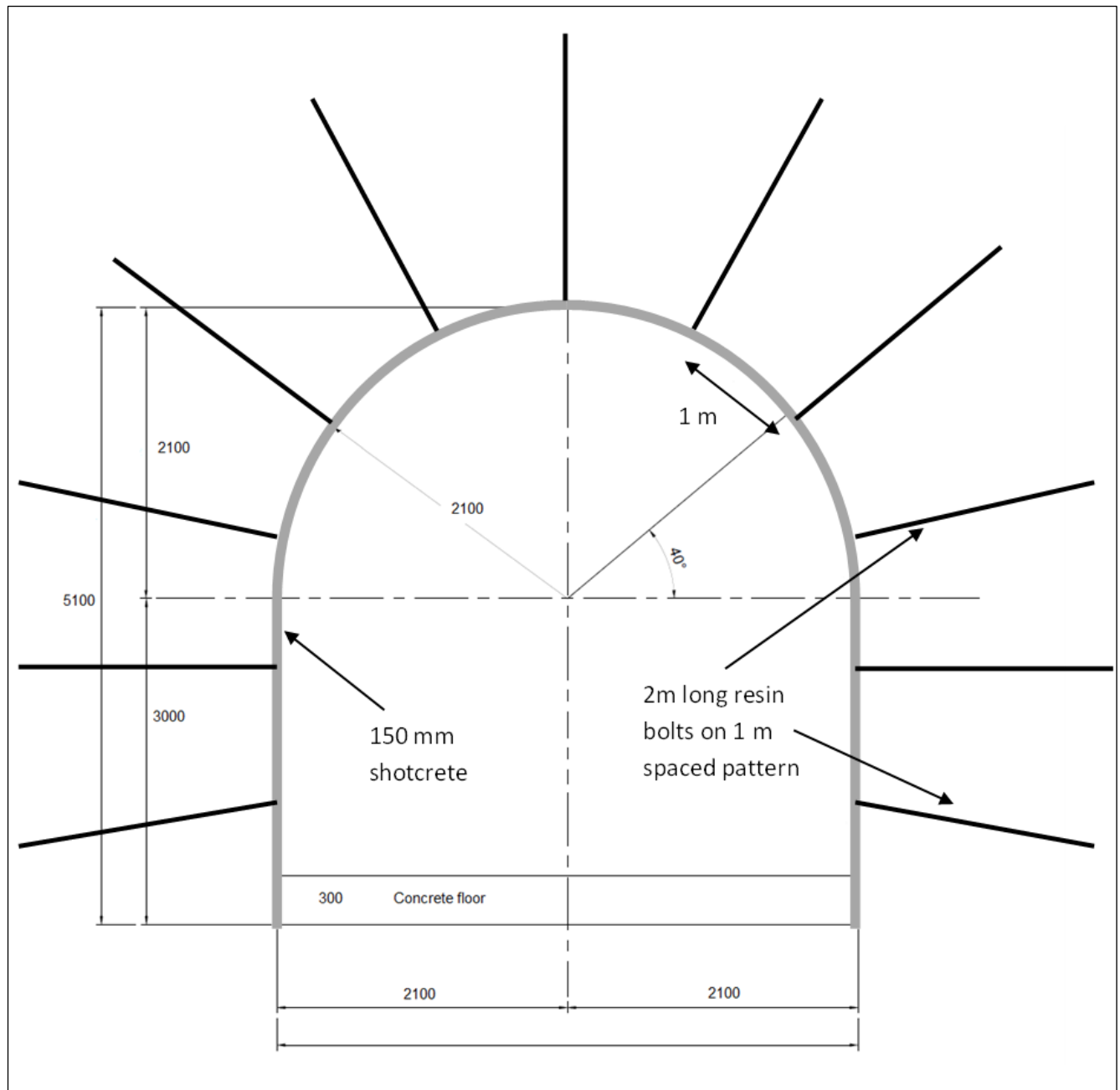

Figure 16.8: Trucking Decline Portal – Cross Section-Beyond 50m

16.2.3 Access excavations and support design

The orebody will be accessed via a central decline and a series of levels and ore drives. A number of other ancillary excavations will also be utilised either for access to or extraction and transportation of the ore. The dimensions of each of the excavations was driven by the selected mining method, access design, equipment selection and ventilation requirements. These dimensions were compared to the dimensions achieved by applying the maximum unsupported span calculation. This was done as a check to ensure that the planned excavation dimensions fall within suitable limits of the empirically calculated dimensions.

Systematic support systems were derived using the guidelines for primary support design (based on rock mass classification) provided by Barton et al, (1974) as well as industry common practice. This approach aims to ensure that design is not conservative and that safety is not compromised. Parameters such as ESR, Q Index and joint roughness ratings (Jr) were taken into consideration.

Several support classes were then defined based on the intensity of support that will be required and the quality of the rock mass encountered. The support classes are presented below, ranging from lowest intensity to the highest intensity. For example, class I support calls for face nets and systematic 1.3m long split sets whereas class IV support requires face nets, 2m long resin bolts as well as 4.5m long cable anchors coupled with 50mm of reinforced shotcrete.

Table 16.7 Underground support requirements

Support classes	Systematic 1.3m long split sets	2m long Resin bolts	4.5m long fully grouted cable anchors	50mm thick reinforced shotcrete	100mm thick reinforced shotcrete	Face nets
I	x					x
II		x				x
III		x		x		x
IV		x	x	x		x
V		x	x		x	x

16.2.4 Sublevel caving design (Predicting the cavability of the Bisie rockmass)

The Laubscher (1990) and Laubscher and Jakubec (2001) systems were used to determine the MRMR which in turn was used to estimate the Critical caving HR (CHR). Prior to establishing the cavability, a crude assessment was undertaken to establish the suitability of the Bisie rock mass to sub-level caving. Laubscher in his "state of the art in cave mining" described the requirements for sub-level caving from among other aspects, geotechnical considerations. These requirements and the perceived performance of the Bisie deposit are shown in the Table below. The first-pass assessment shows that against Laubscher's (1990) requirements, the conditions for sub-level caving are both applicable and suitable. The additional factors that favour the use of sub-level caving for the Bisie deposit are:

- The orebody is stronger (RBS = 58 MPa) than the hangingwall rock mass which suggests that once drilled and blasted, the undercut created will induce caving of the low strength Chlorite (RBS = 28 MPa) and Mica schists (RBS = 42 MPa).
- The rock mass has three dominant foliation parallel joint sets with one crosscutting set discernible. These joints create the degrees of freedom required for rock blocks to delaminate and disintegrate.
- The shear strength of the host rock (chlorite and mica schists) is low. The high k-ratio (1.6) when applied in the direction parallel to strike will exceed the shear strength of discontinuities resulting in easy delamination and rock mass instability.

- The plunge of the orebody is roughly 60 degrees which will ensure hangingwall gravitational instability and free draw of mineralised blasted ore.
- The 60-degree plunge when compared to a vertical orebody will result in minimal undercutting of the toe of the stope into waste material.
- Joint spacings range from 5.88 to 150 cm. Fragmentation of the ore and host rock is expected to be in the region of the mean spacing of 65 cm. A fragmentation analysis has not been conducted and is advised prior to the implementation stage of the project.

Table 16.8 Assessment of cavability using Laubscher (1990) guidelines

MRMR CLASS	1	2	3	4	5
MRMR CLASS RATING	80-100	61-80	41-60	21-40	0-20
Cavability	Very poor	Poor	Fair	Good	Very Good
Cave HR [m]	+50	32-50	18-32	8-18	1-8
Loss of blast holes	Nil	Nil	Negligible	Fair	Excessive
Brow wear	Nil	Nil	Low	Fair	Excessive
Support	Nil	Localised	Low	Medium	Heavy
Dilution	Very low	Low	Medium	High	Very high
Applicability of sub-level caving	Suitable	Suitable	Suitable	Applicable	Not practical

The input parameters for the MRMR 1990 and 2001 systems were informed by the geotechnical data collected and synthesised. The adjustment factors were selected using adjustment tables cited by Laubscher and Jakubec (2001) using the following engineering judgement:

- Since the host rock mass is highly altered and consists of high quantities of chlorite and mica, susceptibility to weathering and degradation was viewed as moderate. The selection of 0.82 is for moderate weathering over 6 months.
- Joint orientation adjustments of 0.7 and 0.8 were made for the highly altered chlorite/mica schists and amphibolite schists, respectively. These adjustments were in line with 3 joints defining the rock mass and the rock type respective joint condition ratings
- Good conventional blasting with a rating of 0.94 was selected
- Due to the low RBS, DRMS and shear strength of the rock mass coupled with the high foliation parallel principal stress adjustments of 0.7 and 0.8 were selected for the chlorite/mica and amphibolite schists, respectively

The resulting MRMR and Critical Hydraulic Radii, 1990 and 2001 are shown in the Tables below.

Table 16.9 Results of Laubscher (1990) MRMR rating

Laubscher, 1990 MRMR System	Based on logging and rock test data			Source of information
	Chlorite schist	Amphibolite	Mica schist	

		Mean	Mean	Mean	
RQD (%)		69.18	74.69	76.07	Actual logging results
Rating		10.38	11.20	11.41	
UCS (MPa)		35.00	53.00	73.00	Rock strength UCS results verified by Triaxial results
Rating		4.00	6.00	6.00	
Joint spacing (m)		0.06 to 1.5	0.14 to 1.5	0.14 to 1.5	Actual logging spacing data
Rating		12.65	15.64	15.64	
Joint condition	Large scale expression	0.75	0.75	0.75	Actual logging frequency plots
	Small scale expression	0.55	0.80	0.55	
	Wall alteration	0.99	0.99	1.00	
	Wall filling	0.82	0.82	0.82	
Rating		13.39	19.48	13.53	
Weathering adjustment		0.82	0.82	0.82	High chlorite and mica content, highly altered
Joint orientation adjustment		0.80	0.90	0.80	Two dominant joint sets and 4 walls
Stress adjustment		0.70	0.80	0.70	Low shear strength and transverse isotropy
Blasting adjustment		0.94	0.94	0.94	Good conventional blasting
MRMR, 1990		17.45	29.04	20.11	Calculated using Laubscher method
Critical hydraulic radius		6.50	12.00	8.00	Laubscher, 1990 caving graph
Equivalent square span		26.00	48.00	32.00	HR x 4

Table 16.10 Results of the Laubscher & Jakubec (2001) MRMR rating

RATING PARAMETER	Chlorite Schist	Amphibolite	Mica Schist
Intact rock strength [MPa]	35.00	73.00	53.00
Adjustment for sample size	0.80	0.80	0.80
Rock block strength [MPa]	28.00	58.40	42.40
Rating value for BS	12.00	18.00	15.00
Joint spacing [m]	0.51	0.66	0.54

Rating for JS	19.00	22.00	21.00
Large scale expression	0.85	0.85	0.85
Small scale expression	0.60	0.65	0.60
Wall alteration	0.99	0.99	1.00
Wall filling	0.60	0.60	0.60
Rating for JC	12.12	13.13	12.24
IRMR, 2001	43.12	53.13	48.24
Weathering adjustment	0.82	0.82	0.82
Joint orientation adjustment	0.80	0.90	0.80
Stress adjustment	0.70	0.80	0.70
Blasting adjustment	0.94	0.94	0.94
MRMR, 2001	18.61	29.48	20.82
CRITICAL HR	8.00	12.30	9.00
EQUIVALENT SQUARE SPAN	32.00	49.20	36.00

The strike spans at which the CHR is attained can be easily be calculated for each cave sub-level. The span related to the CHR denotes both the vertical and strike distance at which caving will occur. The strike span of the orebody is at least 400m, irrespective of the rock type that forms the cave hangingwall, caving will be initiated from the first sub-level as shown in the Figure below.

Figure 16.9: Strike distance at which caving will initiate

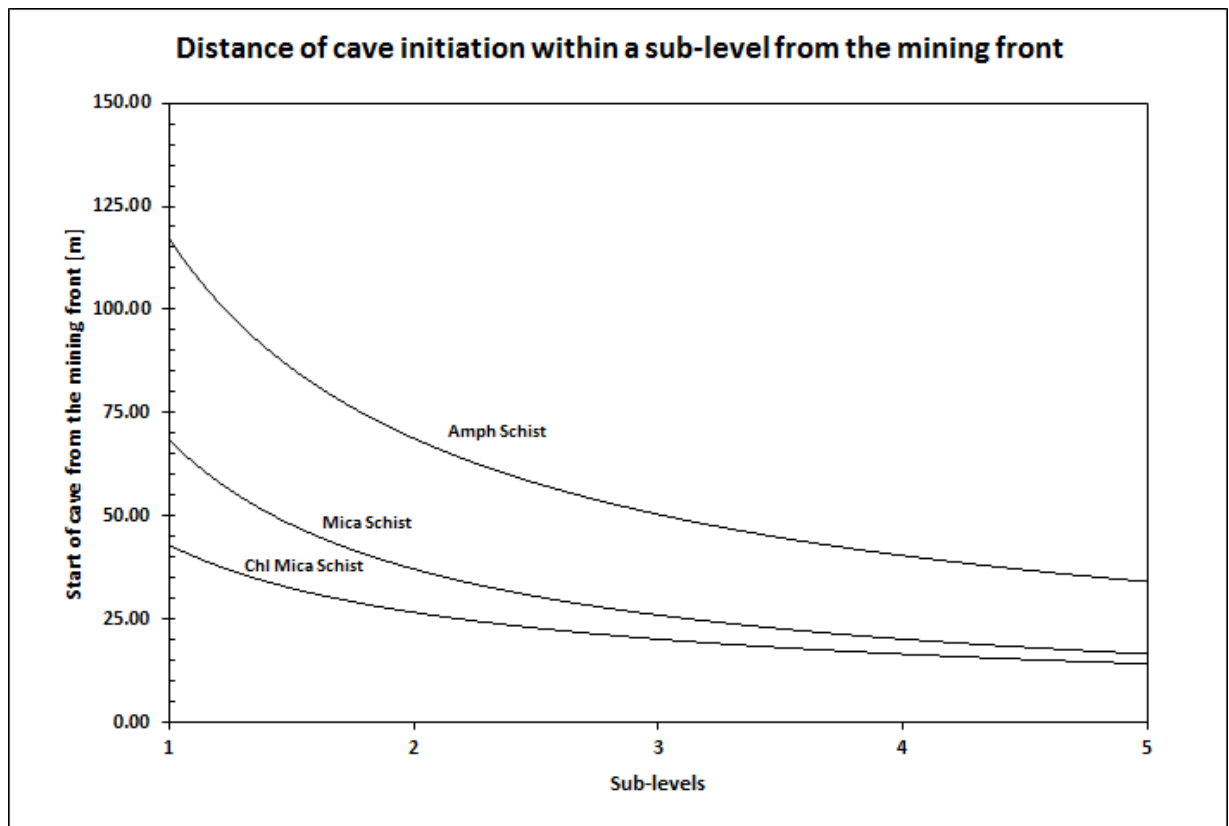

Since at least 45% and 55% of the immediate exposed wall rock susceptible to caving will be in chlorite and amphibolite mica schist, respectively, an assessment of the onset of caving is relevant to both rock types. The following points are made regarding cavability:

- For mineralised zone completely enveloped by chlorite schist, rapid onset of caving is inevitable and will be initiated once a strike span of 45m is opened on the first sub-level. Caving of the subsequent 2nd/3rd sub-levels will occur once the production front is approximately 20m from the first blast. Thereafter rapid caving nearly concurrent with blasting will occur.
- For the higher strength Amphibolite schist, caving will occur within the first sub-level but at strike distances of 120m and improve to 64 and 50m for the 2nd and 3rd sub-levels.
- The results are corroborated by current development of exploration adits within mica schists. The sidewalls of a single drive of 2.7m height and 1.5m width (relatively small width in the context of tunnels) failed at a depth of approximately 80m below surface in similar material that will form the wall rock of the sub-levels.
- Steady state failure of the amphibolite schists occurs at approximately 50m behind the face and for chlorite/mica schist hangingwall at approximately 15-20m behind the face. This occurs from sublevel 4 onwards.

Figure 16.10: Stable and failure stability charts for chlorite and mica schists

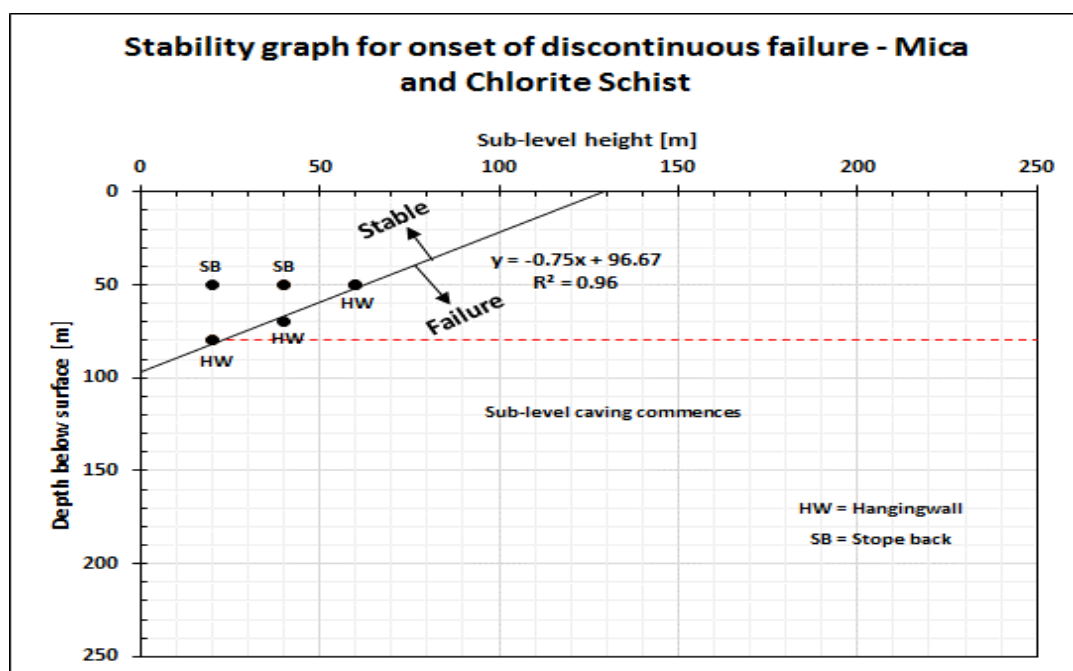
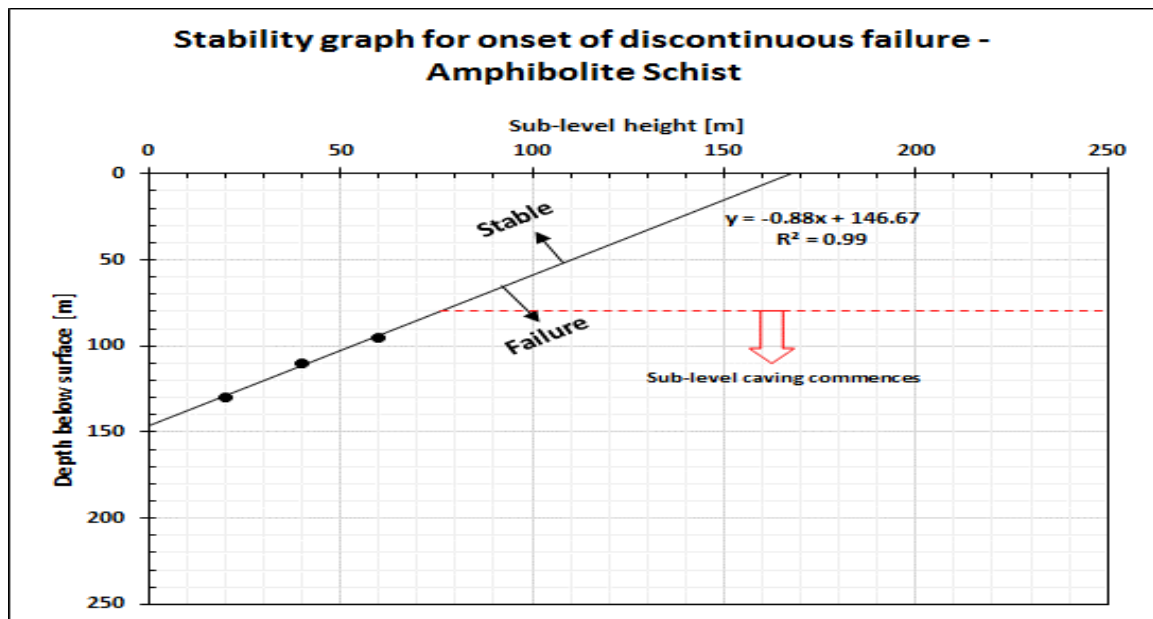

Figure 16.11: Stable and failure stability charts for amphibolite schists



On the basis of the stability charts presented above, the following conclusions can be made:

- A SF of about 0.5 represents complete destruction of material in compression or tension.
- At a vertical depth of about 100mbs (mining starts at 80m), stopes hosted in highly altered chlorite and mica schists will start to fail. This will occur in both the backs and sidewalls. For mica schists SFs rapidly deteriorate to about 0.5 at about 150mbs. At this depth, large scale rockmass failure is expected
- For the higher strength amphibolite schists, the start of failure occurs at about 150mbs. When the third sub-level is developed, SFs reach 0.5 at approximately 220mbs for tensile failure.
- The results indicate that discontinuous caving will occur rapidly at depths of about 150 and 220mbs for chlorite/mica and amphibolite schists, respectively on the assumption that a SF of 0.5 represents complete rockmass destruction.
- Within the context of the vertical extent of mining (80 to 500mbs), caving will occur and will propagate very close to the production front at depths greater than 150mbs.

For Bisie, since the k-ratio has been approximated at 1.6, the horizontal stresses are higher than the vertical component. When the foliation is loaded in the direction parallel to the strike of the orebody, then the rockmass failure is governed by the shear strength of the foliation rather than the rock between the foliation planes. The stresses parallel to the strike of the foliation was estimated and superimposed on the shear strength derived for the joints at depths between surface and 400mbs (see Figure below).

Figure 16.12: Estimated shear failure of joints at Bisie

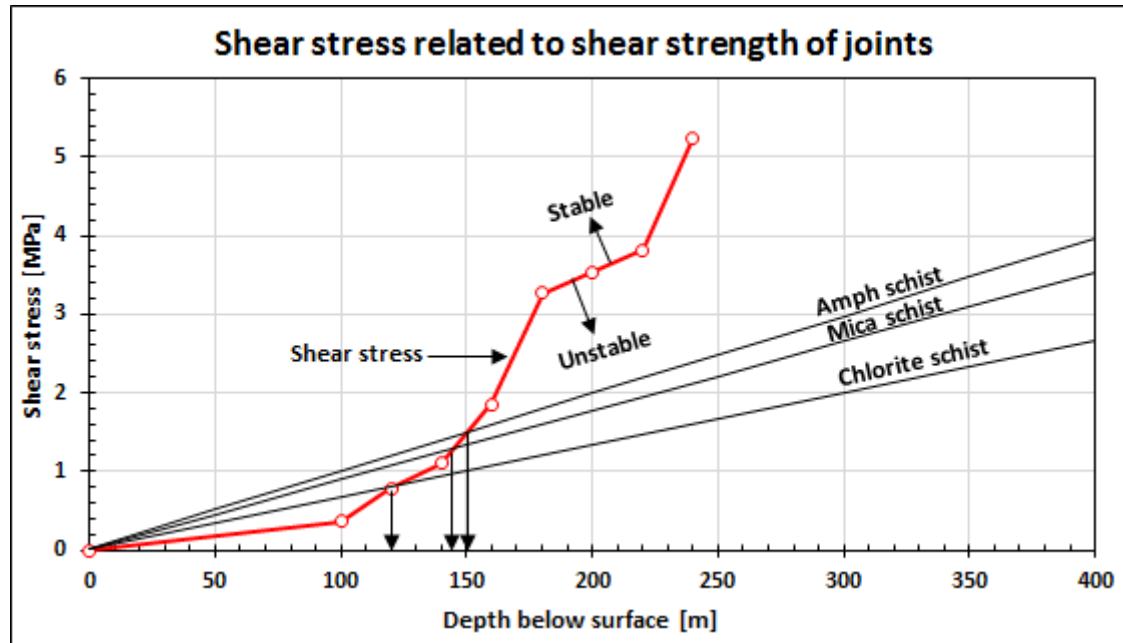

The analysis shows that at depths greater than 120-150mbs, the shear stresses exceed the shear strength of joints and hence joint delamination and failure will occur. This depth range is equivalent to the 2nd/3rd sub-levels. The mine will consist of in excess of 25 sub-levels which implies that shear failure of joints thus initiating rockmass failure will occur in about 90% of all sub-levels.

From the crude estimate of probability of failure, the following conclusions were drawn:

- At 100mbs, the PoF of amphibolite schist is low (5%) but increases to about 88% and close to 100% at depths of 200 and 300mbs, respectively. This confirms the results of the SF analysis using the DRMS method which reports a failure depth of 150mbs.
- For the lower strength chlorite/mica schist, the PoF at 100mbs is 94% which suggests that caving is assured for 45% of the rockmass at this depth.

Estimates of cavability using empirical methods, stress analysis and crude estimates of probability of failure confirm the ability of the Bisie rock mass to support a sub-level caving mining method.

16.3 GROUND WATER STUDY

A groundwater evaluation has been undertaken to support the design of Bisie underground mine. The primary objectives of this study were to:

- Determine groundwater conditions (groundwater flow/volume and groundwater quality) during mining, and after the cessation of mining.
- Evaluate the potential impacts of the main site activities (i.e. mineral processing plant, rock discard dumps and tailings facility).
- Propose conceptual mitigation measures to counter potential groundwater contamination that may result.

A conceptual groundwater model of the aquifer dynamics and characteristics was derived from observations on site, such as natural groundwater base-flow (including springs) conditions, inspection of exploration cores (“extrapolated” to known/similar hard rock aquifers), conditions experienced by artisanal miners and borehole testing of five boreholes. The five boreholes were converted from exploration boreholes. Due to the difficult site access conditions, no additional groundwater data could be collected through conventional methods such as drilling groundwater monitoring boreholes to different depths, and performing pumping tests. Consequently, the information and calculations in this report, which relate to groundwater flow and volumes, should be seen as pre-feasibility level assessments.

By comparison, a detailed geochemical study could be performed. A large number of core, pulp and tailings samples were geochemically studied to determine the anticipated water quality trends during the operational phase of the mine, and over the long-term after mine closure. Consequently, the information and calculations in this report, which relate to the geochemical characteristics and water quality trends of potential sources of contamination, should be seen as definitive feasibility study level assessments.

16.3.1 Potential Impacts Associated with Mining

Initially, very small volumes will be pumped from the mine workings at the highest level of mining (740mamsl), as the average natural groundwater table was estimated at 730mamsl. Groundwater volumes of between 1.2ML/d and 1.7ML/d were predicted for mining level 620, which is the elevation of the Western Valley bottom. The deepest level modelled was 530mamsl (210m deep, 90m below the western valley bottom, 290m above the final mining depth) where groundwater volumes of between 3.3ML/d and 5ML/d were predicted.

Some of the springs and seepage zones (termed “base-flow”) within the dewatering cone will stop flowing, or significantly reduce, when groundwater levels drop and flow directions change toward the mine. However, perched conditions will prevail at some localities due to the high rainfall. The wet and dry rainfall season flows inside the dewatering zone, were estimated at >10L/s and ±5L/s respectively for the most recent wet and dry rainfall seasons. The total impact on the pre-mining total base-flow from the mountain ridge can be described as “small”.

Due to the small neutralising capacity and high acid potential in footwall material, the “residence time” (i.e. time that mine water is in contact with broken rock/ore) will be very important. Pumping designs cater for mine water to be pumped out very quickly, no salt build-up will occur and it is likely that sulphate concentrations will be <500mg/L; i.e. lower than the proposed guideline concentration.

Although As concentrations may exceed drinking water guidelines, it is expected to be below guidelines of the DRC Mining regulations and Equator Principles. Cd concentrations may marginally exceed drinking water guidelines and Equator Principles guidelines; however, no guidelines exist in the DRC Mining regulations. Cu, Ni, Pb and Zn concentrations are expected to exceed drinking water guidelines and Equator Principles guidelines, and may potentially exceed DRC Mining regulation guidelines. It is not known to what extent the mentioned concentrations may improve over time after continued flow through the upper mined-out levels.

Due to groundwater flow being toward the mine during the operational phase, the groundwater quality of surrounding aquifers is unlikely to be impacted.

16.3.2 Management Measures Associated with Mining – Post-Closure Phase

- Groundwater monitoring should continue for a recommended period, as indicated by a qualified hydrogeologist at the time of mine closure, most likely initially on a six-monthly basis, for the same localities and water quality parameters as specified for the operational phase. Groundwater monitoring will depend on the nature and extent of impacts after mine closure.
- The mine access portal should be sealed.
- The mine must be allowed to flood as quickly as possible.
- All mining-related changes to the surface topography during mining which may potentially increase rainfall recharge to the mine (e.g. ponding of water on surface), should be shaped to increase surface water run-off.
- Excess contaminated water on surface can be pumped into the mine. This might also be an option if neighbouring Mpama South is mined after Mpama North.

Given the current conceptual understanding that the final mine water level will be deeper than the pre-mining groundwater table, the mine is not expected to decant contaminated water and therefore no mitigation measures are proposed for mine decant. However, this concept/assumption should be verified prior to mine closure as recommended for the operational phase.

16.4 MINING METHOD SELECTION

A mining method selection study was conducted as part of the feasibility study process and is reported on in the Updated Feasibility Study Report dated 19 June 2016. The result of the exercise was that Sub-Level Caving (SLC) is the preferred mining method for the Bisie tin Project.

16.5 MINE DESIGN

16.5.1 Mining Method Description

Sublevel caving (SLC) is a long hole mining method in which the orebody is drilled and blasted while the surrounding waste is allowed to cave in on top of the ore. The mining face is progressively retreated allowing the waste to cave in behind the mining face. This method is well suited to orebodies where the surrounding rock mass is weak. Sub level caving is typically used in massive orebodies where one or more parallel ore drives are mined transversely across the orebody, which function as mining drives for drilling, blasting and loading. This method has been adapted to suit narrower steep dipping orebodies by mining in a longitudinal direction, parallel to the strike of the orebody.

Figure 16.13: Schematic long section – SLC

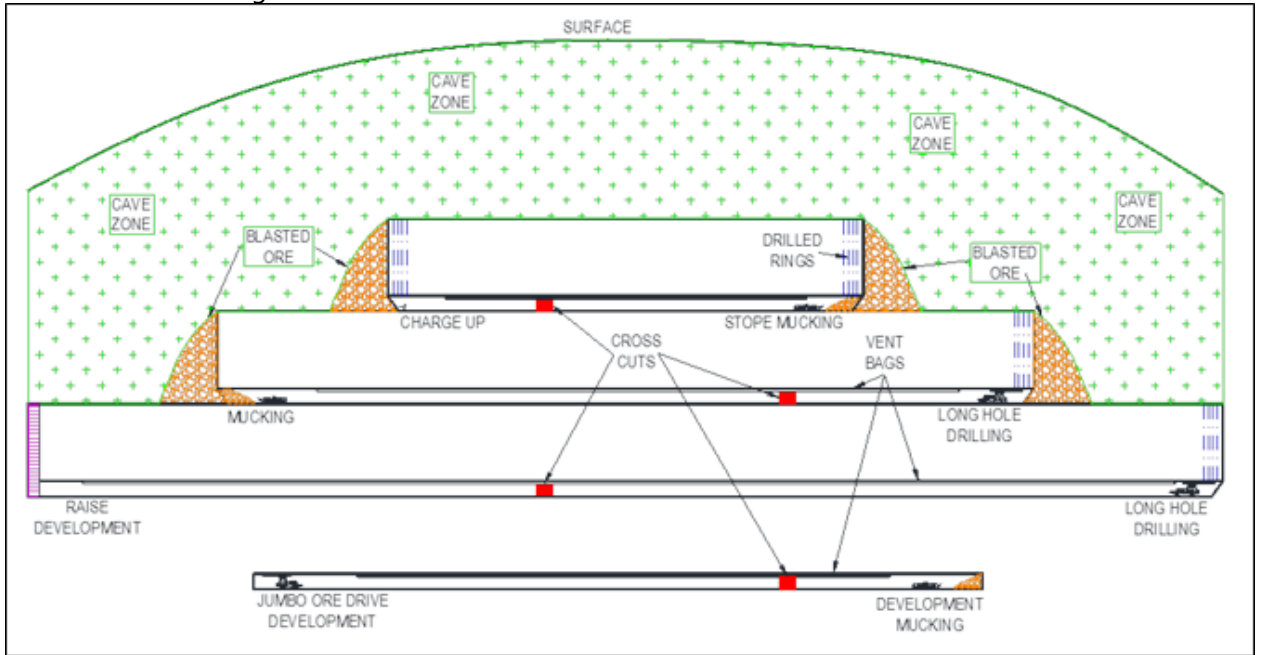
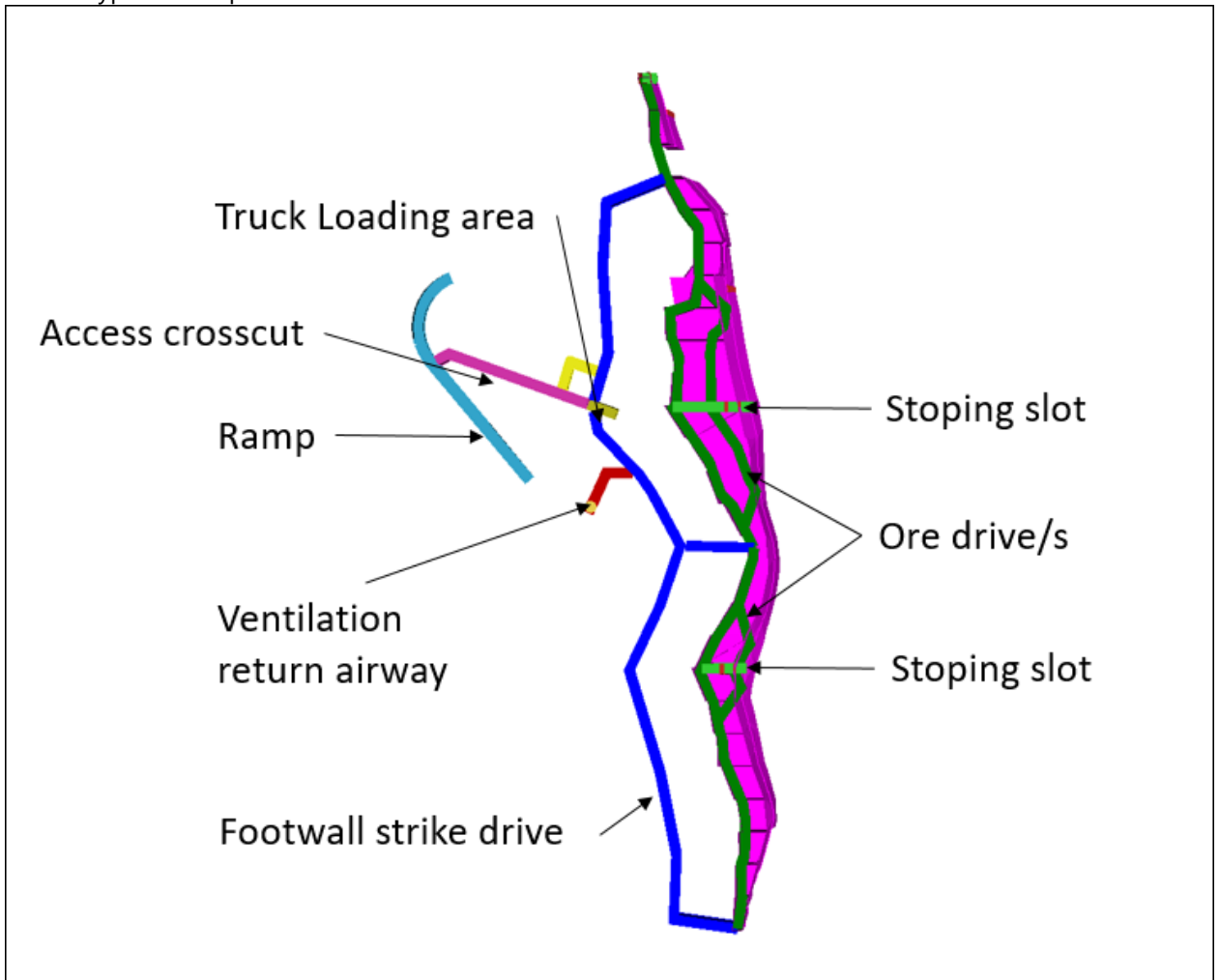

Figure 16.14: Typical level plan – SLC



The success of an SLC operation is dependent on the correct selection of the key design parameters which include:

- Sublevel spacing.
- Mining drive dimensions.
- Blast-hole ring burden.

A set of equations was developed by Janelid and Kapvil (1966) which can be used for the design of a sub level cave layout. The design parameters were calculated using this set of equations.

1.1.1.1 Sub level spacing

A sublevel spacing of 15m was calculated to be appropriate based on the orebody width, blast hole diameter and desired draw ellipsoid to maximise ore extraction while minimising dilution. This will result in blast holes which vary in length from 5 - 17 m.

1.1.1.2 Mining drive dimensions

In determining the dimensions of the mining drives (ore drives) the dimensions and dip of the orebody were considered together with the mining equipment which will operate in the drives. Based on 10 tonne class load haul dump unit and standard long hole drill rig, the minimum dimensions for the ore drive development is 4.0mW x 4.0mH.

The average width of the orebody is 9.0m so on average there will be minimal dilution resulting from mining drive development. Where the mining ore body is wider than 4.0m the mining drive width can be increased to a maximum of 5.5 m to optimise the ore recovery from the sublevel cave. There are areas of the orebody where the width is narrower than 4.5 m and in these areas dilution from mining drive development will occur.

1.1.1.3 Mining Drive spacing

To accommodate multiple, parallel mining drives the orebody must be wider than 20.0m. The recommended spacing (pillar) between the drives is 6-9m. This drive spacing will allow for geotechnical stability of the mining drive.

16.5.2 Primary access and development

Access to the underground workings will be established via a single trackless decline developed at 4.0m wide x 4.5m high. The portal of the Main Decline will be located centrally along strike of the orebody and at an elevation of 710m AMSL. The decline will advance in an easterly direction at an inclination of +2% for the first 50m to prevent the inflow of water into the underground working from intense rainfall events. The ramp will then become the main trucking decline at an inclination of -8%.

Levels are spaced 15m apart vertically and from the trucking decline an access cross-cut will be developed to the orebody. A footwall strike drive is planned 10m in the footwall of the orebody on every level and serves to provide advance geological information and access for equipment to the retreating stopes.

A return airway (RAW) will be established on 740 m RL. The RAW will link the top of the stoping horizon with surface and will be equipped with the main ventilation fan on surface. The RAW will provide an alternative means of egress from the mine in case of emergency and loss of access to the main decline.

The levels will all be connected by a service raise which also acts as a return air raise and emergency means of egress.

Figure 16.15: Isometric view of mine access

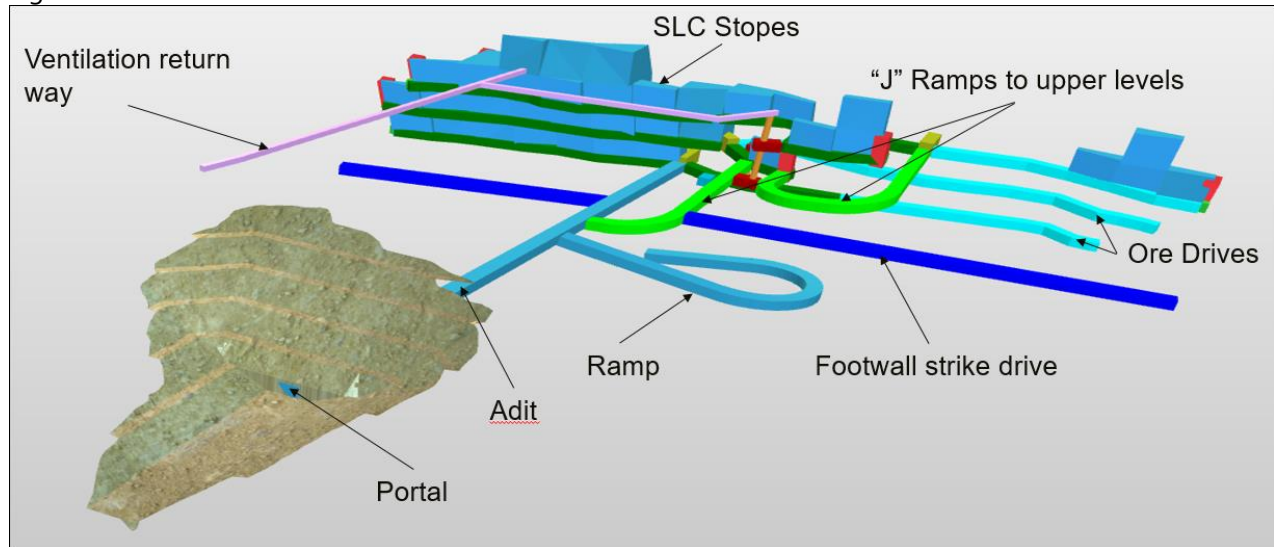

All development will be completed using mechanised drill, blast, support, load and haul methods. Waste rock will be hauled to a designated waste dump situated approximately 1 km from the portal position.

Over the life of mine, some 15 836m of waste development and 15 922m of ore drive development is planned.

Figure 16.16 Development required over the life of mine

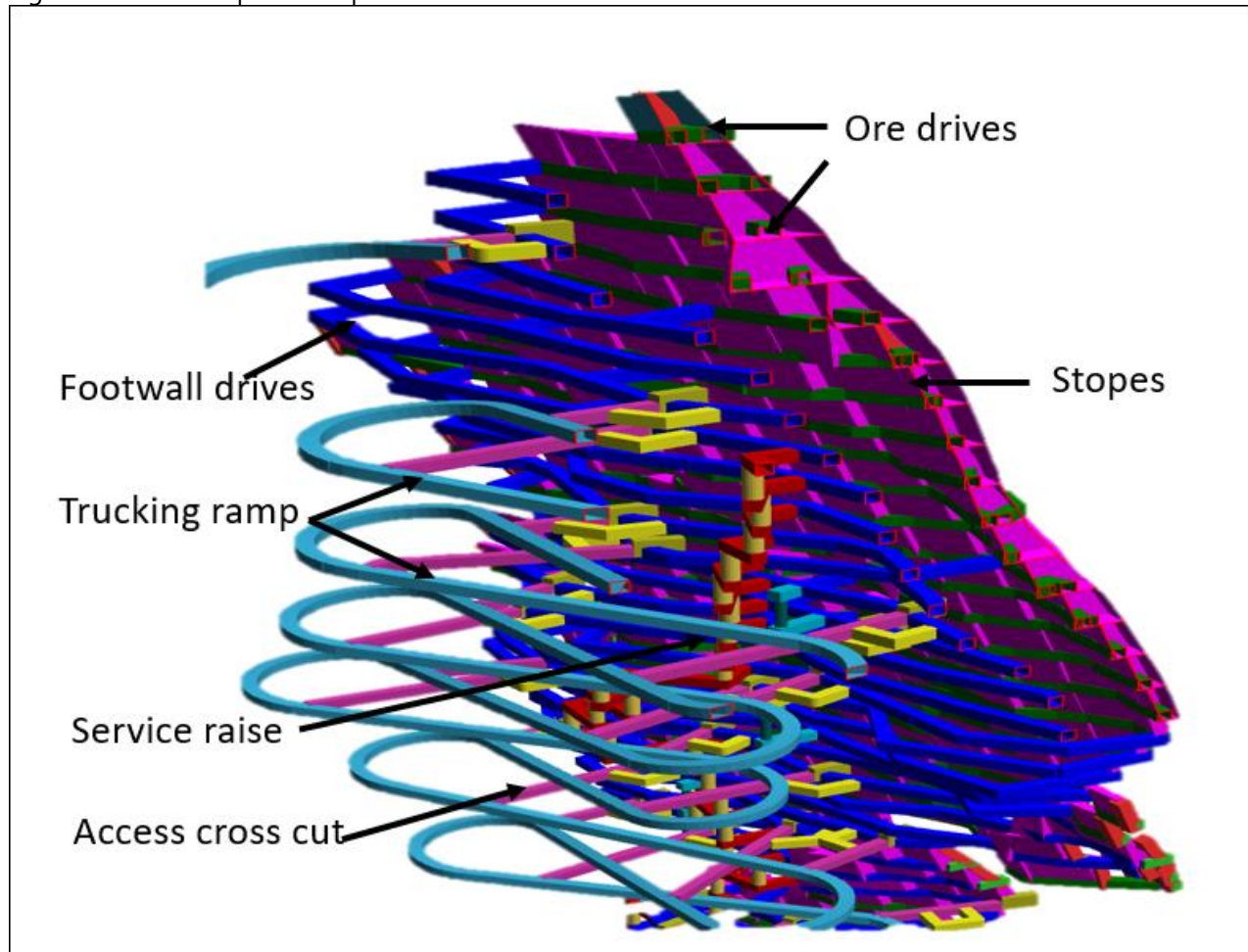

16.5.3 Stoping

Once the lateral footwall and ore drive development on a level is completed and the service raise linking to the level above has been developed and equipped the level is ready for stoping to commence.

Stope preparation starts with the development of a slot raise at the widest point of the block of ground to be mined. The slot raise will be mined at 3.0m x 3.0m and will hole between sublevels. Slot raises will be mined using longhole raising techniques. The drilling of the holes will be completed with the long-hole production rig. Multiple slot raises are planned per level as the stoping plans call for retreating the stoping face from the widest area of the orebody to the narrowest area.

Figure 16.17 Typical slot raise position relative to stoping direction



When the slot raise is completed the raise will be opened up to the full width of the orebody, to form an open face across the width extent of the stope. On completion of this slot the stope is ready for production stoping to commence.

During development of the sublevel information regarding the orebody geometry and grade is collected by two main methods:

- Development sampling. Ore development will be sampled with chip sampling at regular intervals of approximately 3.0m.
- In-fill diamond drilling. Short diamond drill holes will be drilled to intersect the orebody at 15m strike spacing.

Prior to the commencement of stoping on a level a 3-dimensional model of the stope will be developed by the technical services department using all data available to form the basis for stope grade estimation, stope design and blast hole ring design.

The preferred method of operation of the stope is for a number of rings to be pre-drilled and then blasted, one ring at a time. However if ground conditions do not allow for pre-drilling of holes, i.e. holes closure is excessive between the time of drilling and charging of the holes, then rings will be drilled one row at a time, immediately prior to blasting. Only one ring is blasted and loaded at a time as this has been found to produce the best ore recovery in sublevel caving. Blasting of excessive strike length in a single blast allows waste from above to enter the draw point before the ore from the back of the blast has been loaded, resulting in poor ore recoveries.

Figure 16.18 Typical section through SLC slot x/cut with slot raise and blast hole rings

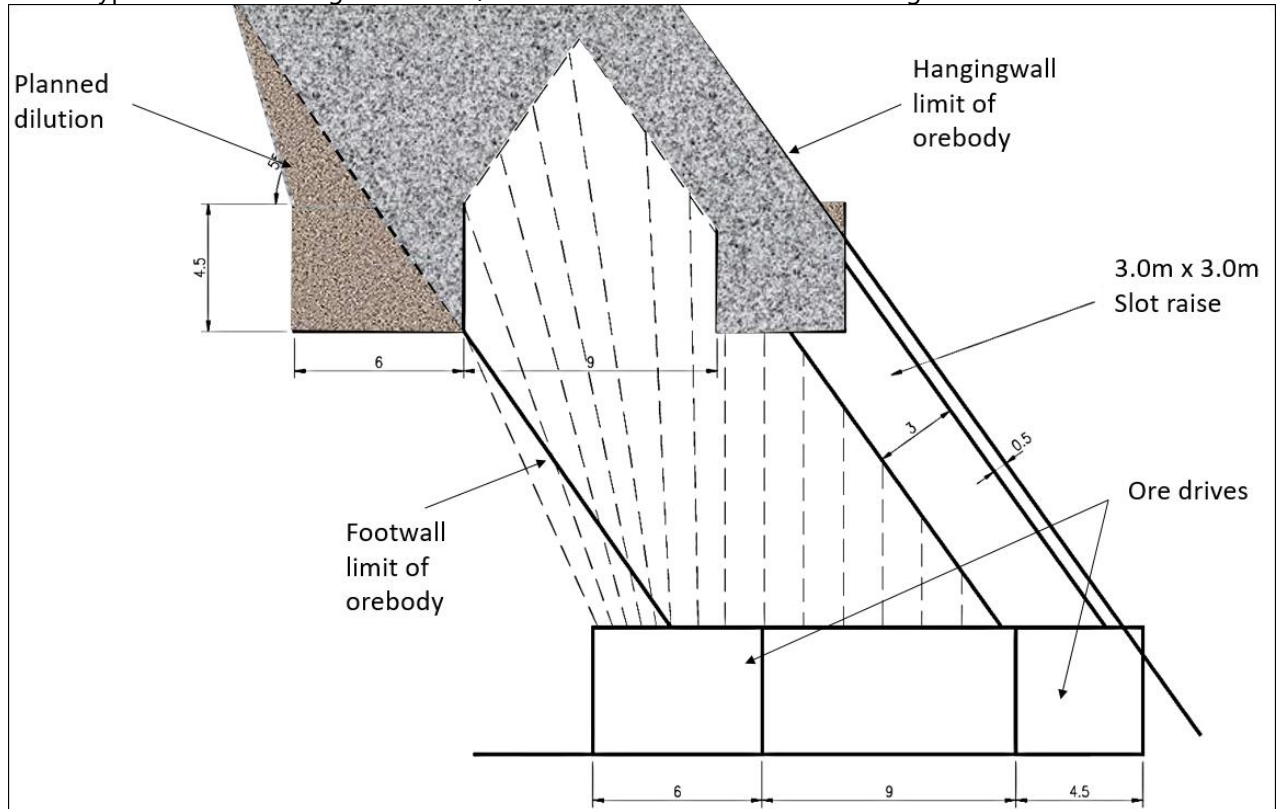

Table 16.11 Blast design parameters for SLC

Description	Value
Hole diameter (mm)	89
Ring burden (m)	2.3
Average toe spacing (m)	1.5
Tonnes per metre drilled	6.1
Explosive type	Bulk emulsion
Explosive density (t/m ³)	1.15
Powder factor (kg/m ³)	3.0
Initiation system	Shock tube short period detonators

The sequence of stoping in sublevel caving is top down. The stope faces will be managed so as to leave a safe lag distance of at least 20m between stopes, with the upper stope leading the stope below.

If this lag distance becomes too small the draw will be negatively affected and ore loss will be negatively impacted.

The Figure below shows an isometric view of the designed stopes and associated grades.

Figure 16.19 Stope design and grades looking north-west

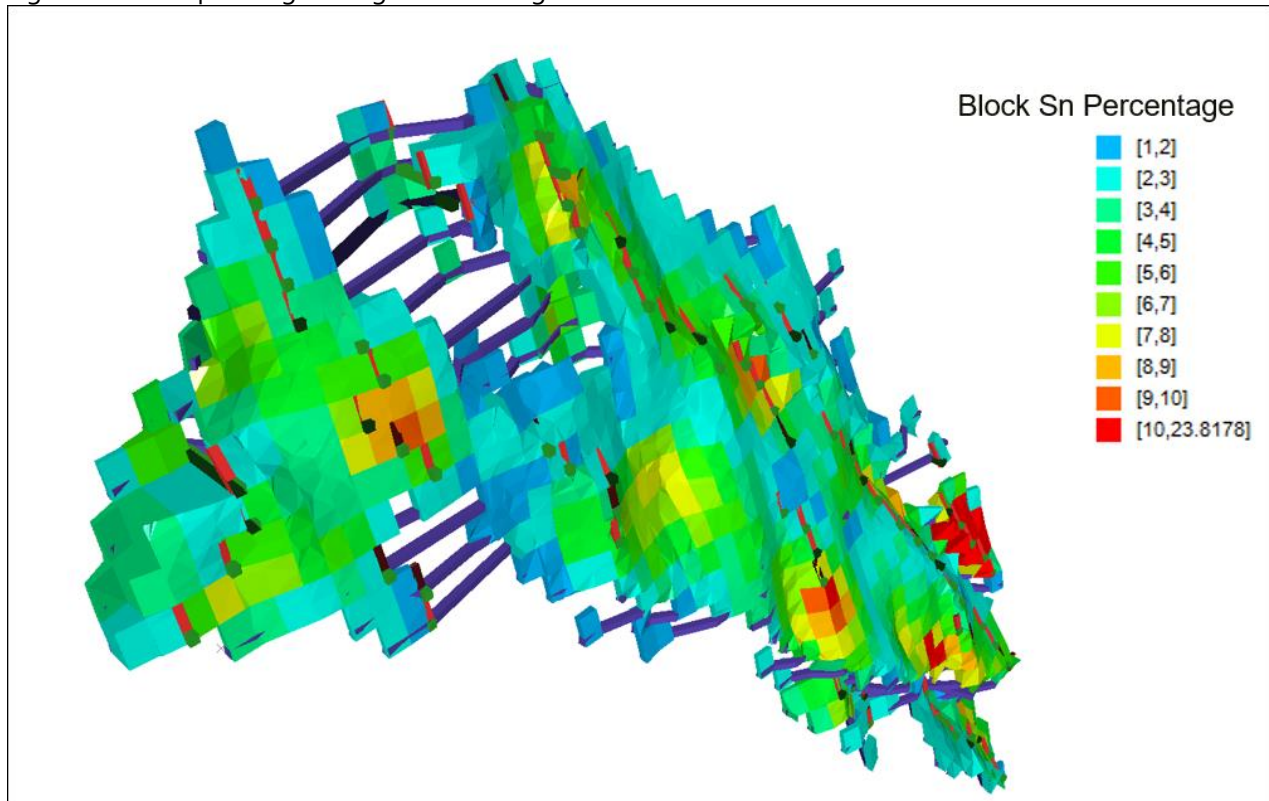

16.5.4 Load, haul and logistics

Blasted ore and waste will be loaded in the face by a 10 t load haul dump unit (LHD), transported to the level access drive and tipped directly into a truck for hauling to surface. The trucks will move ore to the RoM pad on surface and waste to the designated waste re-handling area. Dump trucks will only operate in the decline and level access drives. They will not enter the lateral footwall or ore drive development ends. The LHDs will move the ore and waste from the face, along the lateral development to the central level access position.

All material will be transported into the mine by light vehicle (LDV) or by utility vehicle. Underground workers will travel from surface to their working place by light vehicle.

16.5.5 Equipment selection and productivities

The mining equipment fleet at Bisie has been selected considering the orebody geometry, minimising dilution and maximising productivity. A trade-off was conducted to determine which would be the more efficient between a suite made up of 6 tonne loaders and 20 tonne trucks and one of 10 tonne loaders and 30 tonne trucks. The study showed that the larger fleet was more cost effective as less units were required. The expected benefit of smaller excavations when using the smaller fleet is not applicable as the size of the decline is determined by the intake ventilation requirement, which is in fact greater in the case of the smaller fleet due to increased diesel powered equipment in operation underground.

If the decline dimension is reduced an additional intake ventilation system would be required.

Table 16.12 Selected mining equipment

Equipment type	Model	Capacity	Quantity
Development jumbo	Atlas Copco S1D-DH	180 m /month (multiple heading) 60 m/month (single end)	1
Production drill	Atlas Copco Simba S7	13 m/hour	1
LHD	Atlas Copco ST-10	80 t/hour	1
Front end loader	Bell 1204E	66 t/hour	2
Truck	MAN CLA 25.220 6x4	18 t/hour	5

16.5.6 Cave Management

The sub level caving method is based on confining each blasted ring of ore against a cushion of caved waste in order to keep the ore column at the draw point for loading.

Given that the drilling drives are positioned optimally and the rings designed to ensure good fragmentation the onus then rests heavily on applying strict draw control procedures to achieve satisfactory ore extraction results. Recovery and dilution can vary considerably in sub level caving operations depending on the amount of control exercised over the mining operation. The important aspect of managing the cave have been identified as follows:

- The blasted ore column is constrained in its position against the cushion of waste lying in the previous ring position. The column is drawn using LHDs in accordance with a strict systematic grade control procedure.
- The blasted tonnes and the drawn tonnes from each ring needs to be carefully monitored to avoid overdraw and excessive dilution.
- Broken ground under pressure will tend to hang up resulting in voids being formed. The voids are subsequently filled by waste or ore flowing from the sides down to the angle of repose of about 50°. These voids continually occur during a draw and in most cases they occur out of site above the brow. This ingress of waste into the draw column causes the variable grade profile. If blasting problems occur above the brow the ingress of significant waste can occur soon after draw from the newly blasted ring commences. The capability to recognising this situation early is important.
- Failure of the draw point brow contributes to additional dilution during the loading process. The condition of the brow profile must be kept intact during the draw of a ring. Equal attention needs to be paid to the charging of the ring to ensure the brow is not over blasted.

A key requirement for sub level caving operations, where the ore column is normally drawn blind, is a systematic and well-disciplined draw and grade control procedure. The operations team must

introduce a monitoring system that will allow a full record to be made of the draw from each ring in order to develop the history that will allow a good reconciliation against the stope designs.

16.6 VENTILATION

Ventilation is the primary means of diluting and removing pollutants such as dust, gases, diesel exhaust emissions and heat. The definitive ventilation design for Bisie Mine gives the intended ventilation method, layout, air quantities and the dimensions of the primary and secondary excavations to cater for the air quantities required to achieve the above aims.

16.6.1 Design criteria and constraints

The ventilation design criteria used conform to established international best practices to provide a safe and healthy underground working environment. The Table below lists the principal criteria used in this study.

Table 16.13 Ventilation design parameters

Parameter	Value
Design intake air temperature (wet bulb/dry bulb)	22.0/28.0°C
Design reject air temperature (wet bulb/dry bulb)	30.0/35.0°C
Air to engine rated diesel power ratio at point of use	0.06 m ³ /s/kW
Overall air leakage factor for the mine	20 %
Declines and intake air tunnels air velocity	5 to 8 m/s
Return airways air velocity	Up to 14 m/s
Unequipped air raises and raise bored holes air velocity	Up to 22 m/s
Return air raises with emergency ladders, pipes & cables air velocity	Up to 20 m/s
Minimum design Specific Cooling Power (SCP)	300 W/m ²
Carbon monoxide – Occupational Exposure Level (OEL) - 8 hr shift	≤30 ppm
Carbon dioxide (CO ₂) OEL	≤5000 ppm
Nitrous oxide (diesel gases) OEL	≤25 ppm
Nitrogen dioxide (diesel gases) OEL	≤3 ppm
Respirable combustible dust (RCP) (exhaust soot particles) OEL	2 mg/m ³

16.6.2 Determination of air requirements

The air requirements are based upon the active mining fleet and the standard mine ventilation criteria including:

- Sufficient air to dilute and remove diesel exhaust gases from the active fleet.
- Sufficient air to dilute and remove heat to provide a safe and healthy working environment without requiring refrigeration.
- Sufficient air to ventilate all places where persons work or travel.

- Sufficient air to provide a robust ventilation system to cater for any possible flammable gas occurrences.
- Allowance for the inevitable leakages that occur in mines.

An air to diesel power ratio of 0.06 m³/s/kW at point of use has been used to determine ventilation requirements.

Table 16.14 Air requirements based on active diesel powered fleet

Total Requirement	Units	LHD	FEL	Truck	Rigs & Bolter	Service Vehicle	Total
Mining equipment required	ea	1	2	5	5	4	
Engine kW rating	kW	202	95	134	80	80	
Utilization		14%	57%	85%	80%	75%	
Total kW	kW	28	108	569	320	240	1 264
Air requirement (@0.06m ³ /s/kW)	m ³ /s						75.9
Leakage allowance 20%	m ³ /s						15.2
Total Airflow requirement	m ³ /s						91

The airflow velocity for the total airflow requirement in the 4.5m x 4.0m trucking ramp is 5.1m/s.

16.6.3 Air distribution

The mine, for ventilation purposes, will have 3 stages.

- Stage 1: Development of the initial intake decline and the return decline/emergency outlet.
- Stage 2: Developing in to the orebody and internal ventilation drop raises and continued development of the main access decline downwards.
- Stage 3: Steady state production.

The primary air distribution at steady state is shown in the figure below.

Figure 16.20: Schematic diagram of the mine ventilation layout

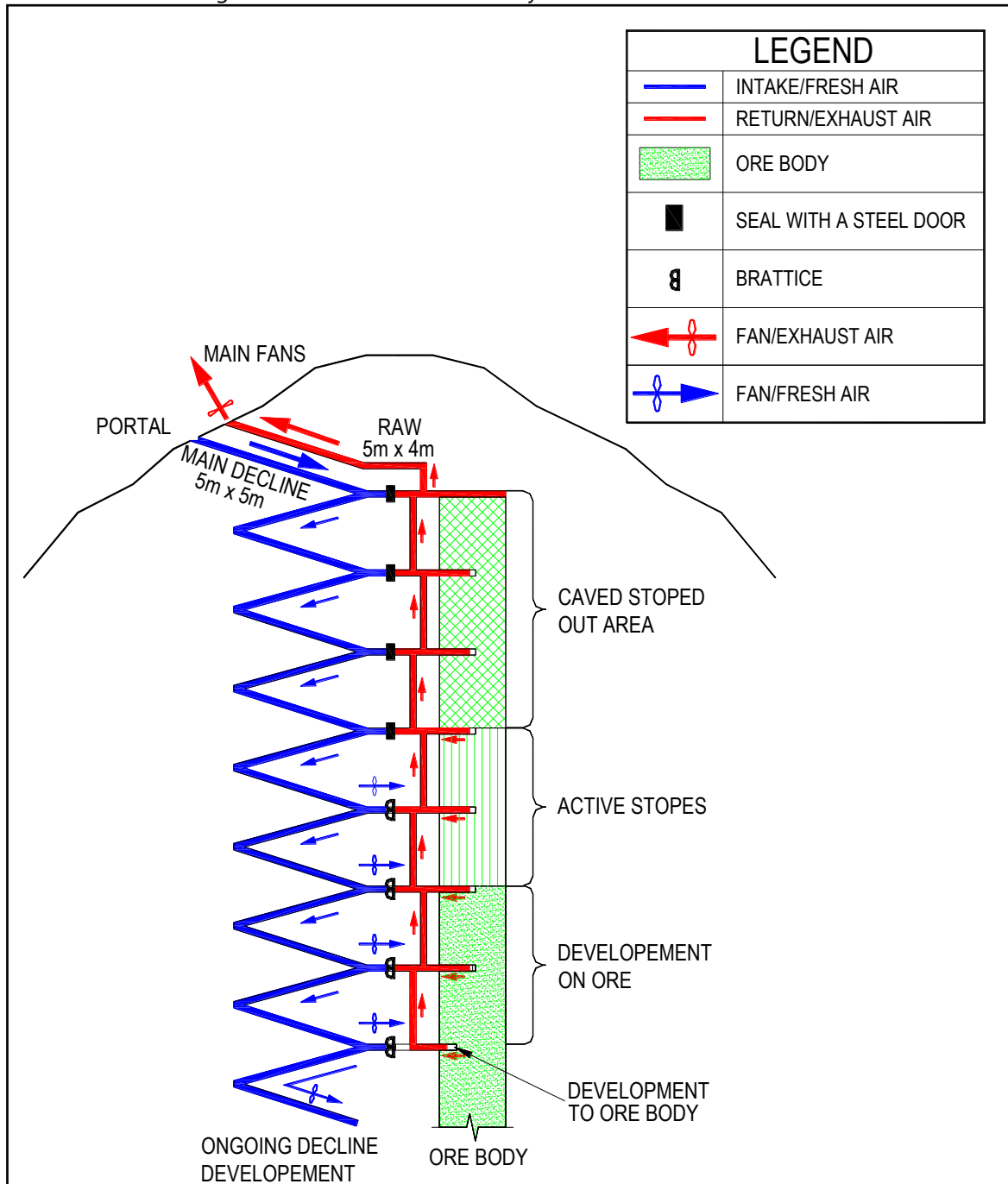

The intake ventilation system will consist of a single 4.5 m x 4.0 m (finished size) decline. This decline will extend from the surface portal into the first level position and thereafter be developed downwards in a spiral layout as discussed previously. Fresh air will be sourced from the decline and delivered to the working areas as required.

The return ventilation system will consist of a series of 3.5 m x 3.5 m drop raises going from level to level (nominal 15 m level spacing). These drop raises will be equipped with an emergency escape ladder as well as being used as a service raise. A certain amount of used air will also exhaust through the mined out area. The air from the upcast drop raises and the old workings will be exhausted via a RAW to surface where air will be extracted at the fan station.

16.6.4 Fans

The main fans will consist of 2 x 250 kW axial fan units installed in a duty/standby arrangement, situated at a single fan station at the upper terrace on surface at the return air decline. The nominal design operating point of each fan is 95 m³/s at 1.9 kPa at an air density of 1.05 kg/m³.

Figure 16.21: General arrangement of main fan

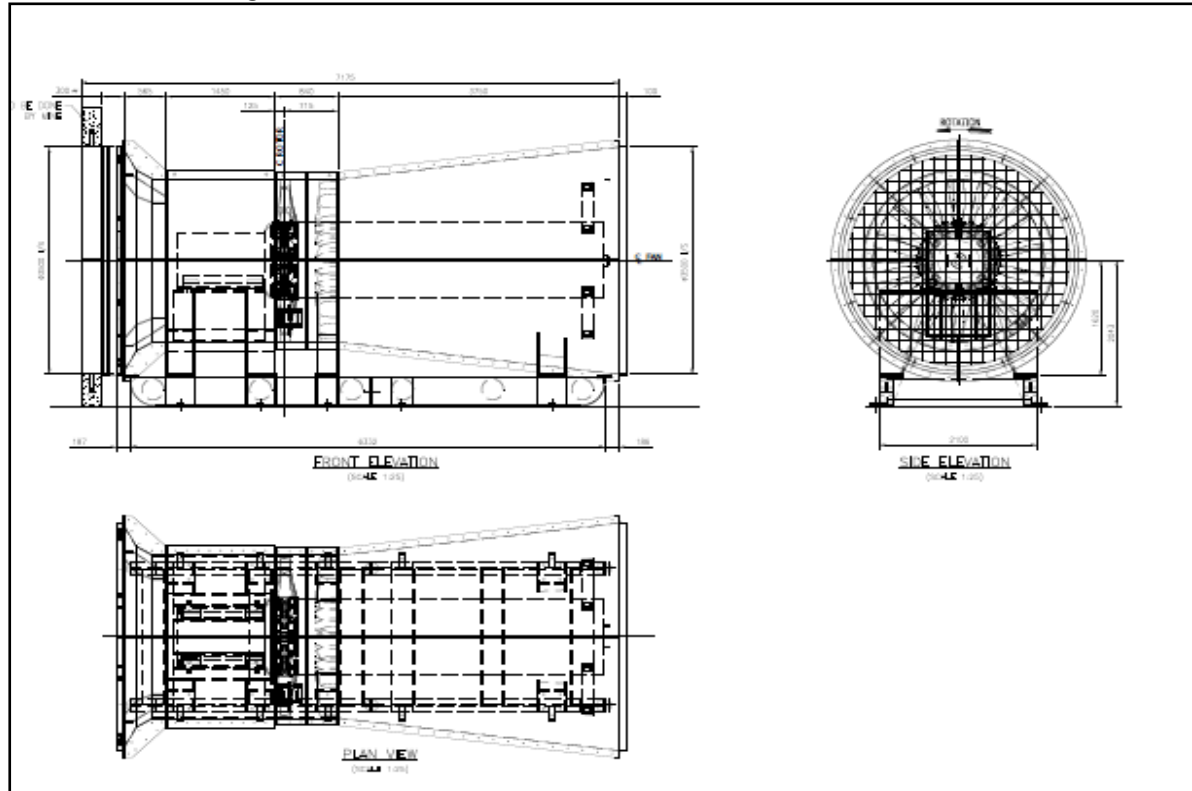

The secondary fans are used for development of the decline, level access drives, ore drives and stoping operations. These fans are conventional off the shelf 1,016 mm diameter development fans that are equipped with silencers. These fans are used in force configuration with the fans placed at the column intake. Decline development and longer ore drives use 75 kW fans with other development and stoping using 55 kW fans.

The power requirements for the fans are given in the table below.

Table 16.15 Fan and power requirements

Fans	No.	kW	Total kW
Main (surface)	1	250	250
Decline development	2	75	150
Tunnel development	6	55	330
Stopes (columns)	8	55	440

16.7 MINE SCHEDULING

Development rates were calculated based on equipment cycles, productivities and drilling rates for application in the mining schedule.

Initial development focuses on constructing the mine access through two adits and accessing the first level. The upper drive will connect to the primary ventilation fans with the lower drive connecting to the decline. Prior to any stoping occurring, these access drives and all level development on the upper level will be completed. Decline development will continue to provide access to the lower levels of the orebody. Slower development advance rates were applied in the initial months of project development to account for slow sinking from surface and the associated poorer ground conditions expected in the near surface weathered zone.

Table 16.16 Mine scheduling parameters applied

Description	Units	Rate applied
Development rate (0 - 10m in decline)	m/month	10
Development rate (10 – 25m in decline)	m/month	15
Development rate (25 - 50m in decline)	m/month	25
Development rate (50 – 80m in decline)	m/month	30
Development rate (80 - 130m in decline)	m/month	50
Development rate (130 – 1250m in decline)	m/month	60
Multiple end development rate	m/month	180
Maximum draw per stope	t/month	13 500
Stoping rate	t/month	27 000

Level development will take place on one to two levels in advance of stoping to ensure sustainable and continuous stoping operations.

Average development rates vary throughout the schedule depending on the number of available headings and whether priority headings are under development. The figure below shows the development profile for trucking ramp, footwall drives, access cross cuts and J-ramps over the project.

Figure 16.22 Development profile over the life of mine

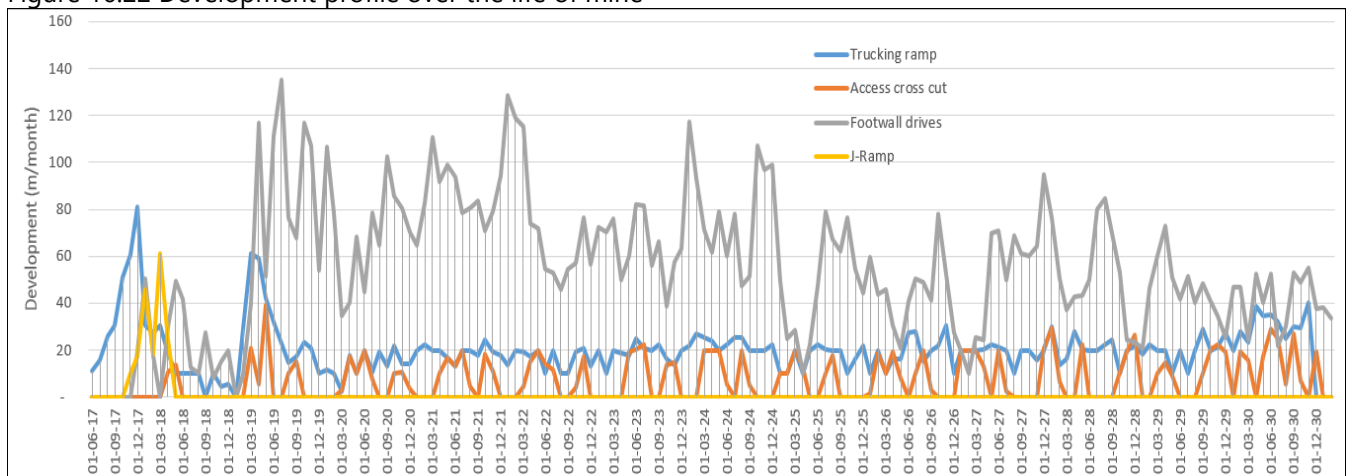

Following the development of a level, slot raises will be developed in the widest part of the orebody and the stope will be mined in retreat towards the nearest access point. Material will be loaded from the retreating face hauled through the ore drive by FEL for truck loading or stockpiling in the access cross cut for later loading onto trucks.

The ore production from development and stopping activities is presented below.

Figure 16.23: Ore production profile

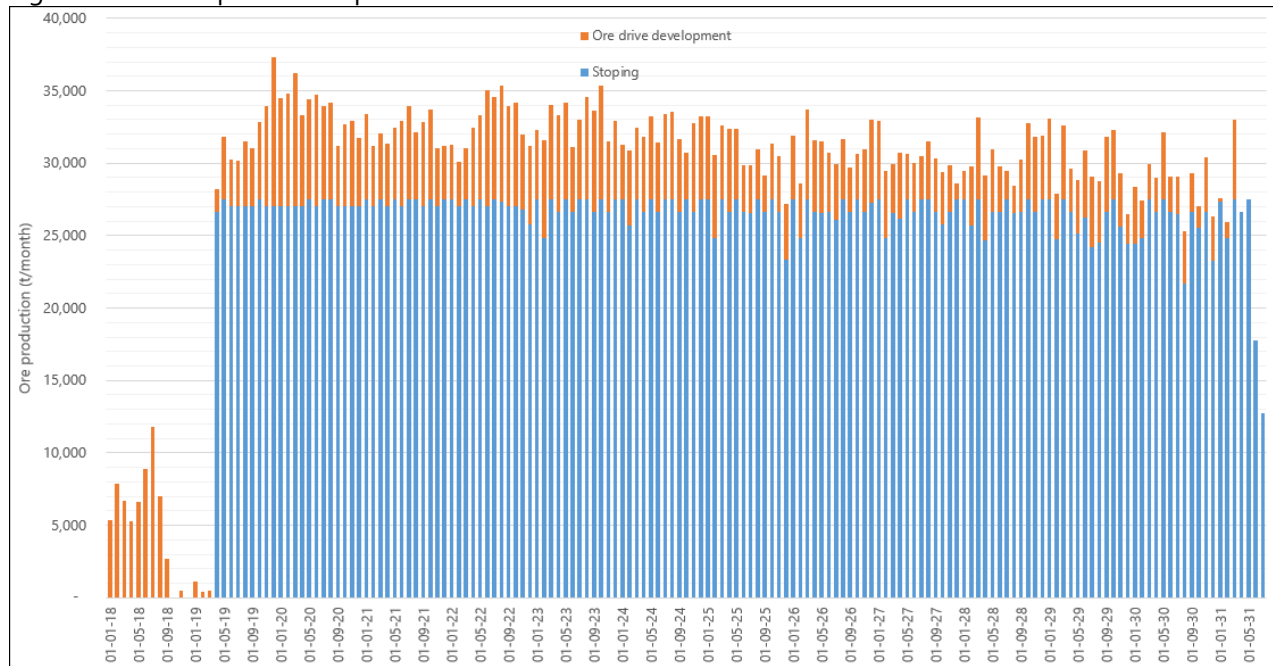

The annualised life of mine schedule is tabled below.

Table 16.17 Life of mine schedule

Bisie Production Schedule	Unit	Total	2017	2018	2019	2020	2021	2022	2023	2024	2025	2026	2027	2028	2029	2030	2031
Stoping Tonnes	t	3,933,644	-	-	243,603	325,490	327,475	324,868	323,749	324,636	318,650	321,116	320,640	320,942	310,619	307,652	164,204
Stoping Sn Tonnes	t (Sn)	145,854	-	-	11,432	12,231	10,906	9,456	9,245	13,051	10,035	8,922	10,832	13,770	18,378	11,422	6,174
Stoping Sn Grade	%	3.71%	-	-	4.69%	3.76%	3.33%	2.91%	2.86%	4.02%	3.15%	2.78%	3.38%	4.29%	5.92%	3.71%	3.76%
Ore Development Tonnes	t	738,905	-	62,616	45,450	79,226	60,693	69,543	73,662	61,690	51,411	52,762	43,219	45,973	50,057	35,720	6,884
Ore Development Sn Tonnes	t (Sn)	22,134	-	1,495	1,225	2,463	1,596	2,037	2,366	1,376	1,209	2,122	993	2,027	1,839	712	674
Ore Development Grade	%	3.00%	-	2.39	2.70%	3.11%	2.63%	2.93%	3.21%	2.23%	2.35%	4.02%	2.30%	4.41%	3.67%	1.99%	9.78%
Total Ore Tonnes	t	4,672,549	-	62,616	289,053	404,716	388,168	394,411	397,411	386,326	370,061	373,879	363,860	366,915	360,676	343,372	171,088
Total Sn Tonnes	t (Sn)	167,988	-	1,495	12,657	14,693	12,502	11,493	11,611	14,428	11,244	11,044	11,825	15,797	20,218	12,134	6,848
Average Grade	%	3.60%	-	2.39	4.38	3.63	3.22	2.91	2.92	3.73	3.04	2.95	3.25	4.31	5.61	3.53	4.00
Waste Development Metres	m	16,233	424	778	649	620	711	790	843	973	1,120	1,249	1,404	1,542	1,651	1,684	1,793
Ore Development Metres	m	12,575	-	1,418	1,330	1,170	1,037	930	877	762	604	508	525	621	747	957	1,091
Total Development Metres	m	28,808	424	2,197	1,979	1,790	1,748	1,720	1,720	1,735	1,725	1,758	1,929	2,163	2,397	2,641	2,884

16.8 UNDERGROUND MINE INFRASTRUCTURE

16.8.1 Service Water Handling

The mine service water requirements have been calculated using empirical usage ratios. The system has been designed to service production and development rates of 360ktpa ore and 60ktpa waste. Over a 23 day per month shift cycle and a usage ratio of 0.5 tonnes of water required per tonne of rock broken, a total of 0.76 ML/day of service water is required. With two drilling shifts at an effective 6 hours per shift, a peak system load of 17.6 l/s may be expected.

Table 16.18 Mine service water usage

Description	Value	Unit
Ore production	30,000	tonnes/month
Development	5,000	tonnes/month
Days per month	23	day/month
Drilling shifts per day	2	shift/day
Drilling hours per shift	6	hr
Service water production	0.5	tonne/tonne
Service water development	0.5	tonne/tonne
Service water requirements	17.50	ML/month
Peak service water requirement	17.61	l/s

Service water will be supplied to the underground mine by a service water header tank located on surface. The header tank will be located above the access portal and will be provided water from the surface mine water treatment facilities situated at the surface complex. The mine water header tank will be the primary collection and distribution point for all mine water.

From the service water header dam, service water will be reticulated through the access portal and service raises into the underground workings. The system pressure will be controlled through a series of cascade dam installed on every third level. Each cascade dam will provide service water to the levels situated 30, 45 and 60 metres below.

16.8.2 Dirty Water Handling

The dirty water handling system will serve to collect and transfer mine production and development water from the mining areas. The system has been designed to accommodate the service water load from the mining activities in addition to a constant ground water inflow rate of 5.0 ML/day.

Table 16.19 Mine dewatering pumping requirements

Description	Value	Units
Service Water per Day	0.76	ML/day
Fissure Water	5.00	ML/day
Total Pumping Requirement	5.64	ML/day
Pumping Duty (16 Hours)	100.02	l/s

Dirty water from the production areas will be transferred to dirty water pump stations by means of submersible pumps. The ore drives are developed at an inclination of 1 in 200, such that all water from the stopping areas report to the entrance to the ore drive. A submersible pump will transfer this water to the dirty water pump station through HDPE piping and, where appropriate, annex holes. Dirty water from the development ends will also be transferred to the dirty water pump stations by means of submersible pumps.

The first dirty water pump stations will be situated between level 3 and level 4, with subsequent pump stations positioned every 90m vertical. A modular system has been designed to allow for additional inflow of ground water below 610mL.

Figure 16.24: Dirty water handling schematic

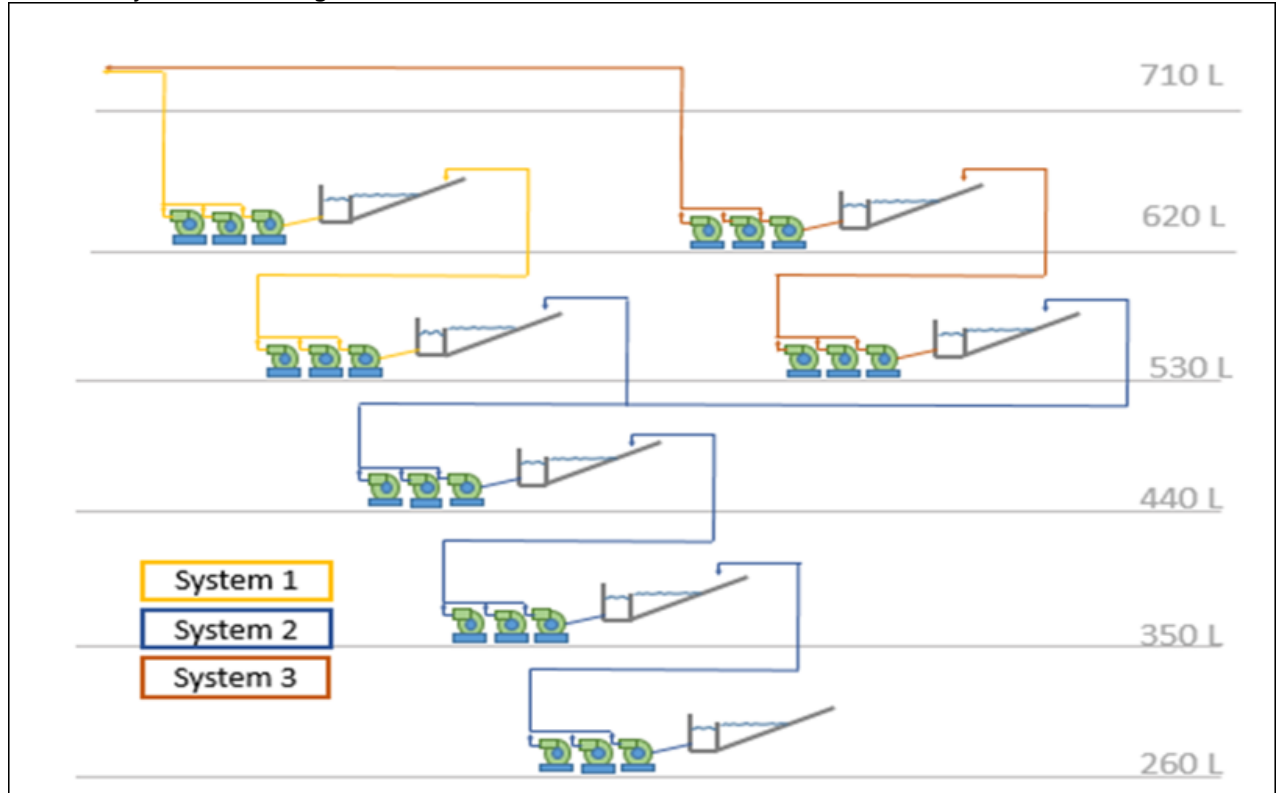

The dirty water pump stations will comprise two 75kW centrifugal pumps capable of pumping slurry at a rate of 100l/s. One of the pumps will be operational at any given time, with the other pump used as a standby for maintenance or breakdown periods. The pumps will be controlled through level control, switching on and off based on the level of the dirty water dam. The dirty water dam will be 15m in length, 5m in width, and have a live height of 2.7m.

16.8.3 Compressed Air

The underground compressed air system will be used solely for the ventilation of refuge bays. The system will be designed on an air usage factor of 85 l/minute per man. The factor allows for respiratory requirements in emergency situations and dilution of CO₂ build up in confined areas.

Table 16.20 Compressed air requirements

Description	Value	Unit
No. of people per shift	120	people
Usage ratio	85	l/min/man
Compressed air flow rate	10,200	l/min
Compressed air flow rate	0.170	m ³ /s
Compressed air flow rate	0.164	kg/s
Compressed air flow rate	360	CFM

The compressed air will be reticulated through the service raises. The refuge bays will be capable of housing 40 people and will be equipped with chemical toilets, first aid kits and telephone communication. The installation consists of a brick wall and ventilation door, built in a disused stockpile.

16.8.4 Electrical

The electrical design described here caters for the electrical reticulation and equipment required to supply the surface 400V and underground electrical loads.

The peak power requirement for the mining and portal surface 400V reticulation is calculated at 3.1 MVA, and occurs in year 12 of the mining operation. The table below provides the detail regarding the peak load calculation and the Figure below provides the annual load build-up for the life of mine.

Description	Connected Power (kW)	Running Load (kVA)
Portal surface infrastructure	884	880
Decline development	664	580
Stoping	676	747
Level 1 - 4 reticulation	393	236
Level 5 - 8 reticulation	393	236
Level 9 - 12 reticulation	393	236
Level 13 - 16 reticulation	393	236
Level 17 - 20 reticulation	393	236
Level 21 - 24 reticulation	393	236
Total	4 582	3 629
Diversity Factor		85%
Peak Load (kVA)		3 085

16.8.5 Communication

A telephone communication will be provided underground at the refuge bays and pump stations. The telephone system will connect into the office PABX system at the surface control room.

17 RECOVERY METHODS

17.1 OVERVIEW

The previous flow sheet for the Bisie tin plant was designed to treat 500 000 t/a of ore, however it would be operated for a reduced number of hours initially to bring down its throughput rate to 360 000 t/a. The revised flow sheet is designed to treat a maximum of 360 000 – 430 000 t/a of ore at an average grade of approximately 3.6% tin and produce approximately 15 500 t/a of tin concentrate. The other major difference is that the oxide flotation process has been replaced with a gravity circuit instead. The plant comprises of the following processes:

- Crushing of Run of Mine ("RoM") ore to -8mm.
- The -8mm material is fed into jig separators.
- Screening post the jigs separates the crushed ore into -8mm +1mm and -1 mm fractions.
- The -8mm +1mm HG jig concentrate is milled to 80% -425µm and processed using gravity spiral concentrators and shaking tables.
- The -8mm +1mm HG jig tailings is discarded to a tailings stockpile, part of the tailings storage facility (TSF).
- HG shaking table concentrate is bypassed directly to product recoveries.
- HG shaking table middlings is milled and directed to sulphide flotation circuit.
- HG spiral tailings is directed to the LG regrind circuit.
- The -1 mm screened from the jig floats and sinks is processed using gravity spiral concentrators and LG shaking tables. The concentrate from the circuit is combined with the HG shaking table middlings and ground ahead of sulphide flotation. The middlings from the LG circuit is combined with the HG spiral tails and reground to 80% -106µm. The combined stream is then directed over another stage of shaking tables whose concentrate is directed to sulphide flotation circuit.
- The -1 mm spiral tails, sulphide flotation and LG regrind shaking table rejects are thickened and discarded.
- Combined final gravity concentrates and sulphide float product is treated through a magnetic separator to remove iron, then filtered and bagged for sale.

The crushing circuit will have an utilisation of 5 200 hours annually and the remainder of the plant will have a utilisation of 7 000 hours annually.

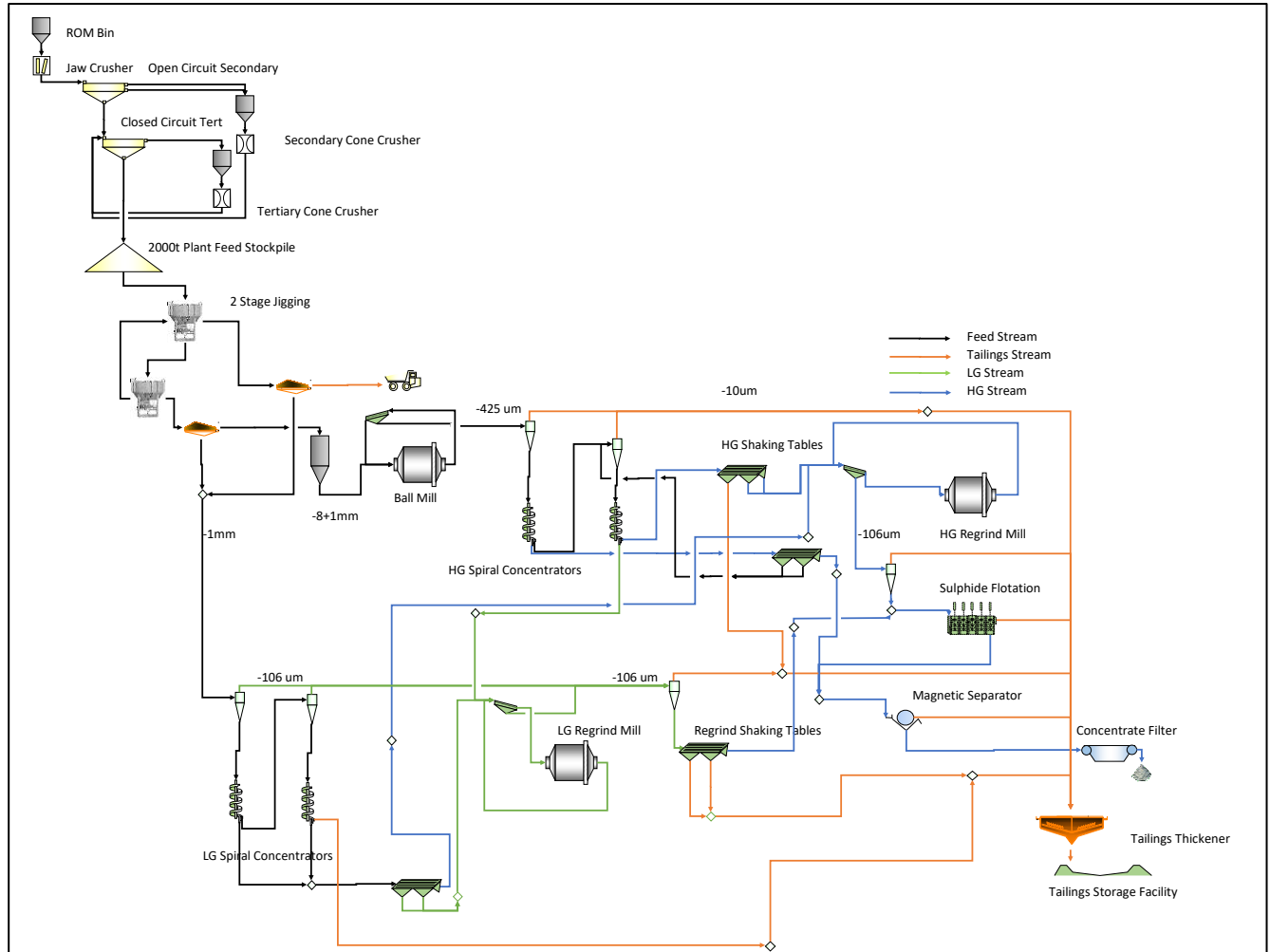

Figure 17.1: Process plant flow sheet

17.1.1 Ore Handling and Preparation

The plant will be fed with ore by a combination of truck and front-end-loader ("FEL") from a mine stockpile. A primary jaw crusher will reduce the ore from approximately -450mm to less than -150mm. The ore will then be screened and crushed in a secondary and a tertiary cone crusher. The tertiary crusher will be in a closed circuit with a screen. The final crusher product will be -8mm. Crushed ore will be stored on a stockpile and reclaimed by FEL via a small intermediary bin and belt feeder arrangement that will feed the rougher jig. The jig product and discard will be screened at 1mm, with the -1mm being pumped to the low grade circuit and the +1mm jig concentrate being conveyed to the high grade primary mill. Test work results indicated the split is expected to be 75% coarse, 25% fine.

17.1.2 Coarse Treatment (High Grade)

The -8mm plant feed from the bin will be jigged in two stages, roughing and cleaning. Jig floats will be discarded. Jig sinks will be milled to 80% -0.425mm to further liberate tin. A peripheral discharge ball mill in a closed circuit with a screen will be used. Milled material will be subjected to gravity concentration on a series of spiral concentrators and shaking tables. The spirals will be configured in a rougher and scavenger arrangement and the shaking tables will be used as cleaners. HG Concentrate will be bypassed directly to the magnetic separator feed, while the HG middlings will be reground in a

closed circuit ball mill to 80% -106 μ m to liberate fine tin. This stream will then feed a sulphide flotation circuit for sulphide removal. HG spiral tailings will be combined with the LG shaking table middlings and directed to a LG regrind ball mill.

The sulphide flotation circuit will consist of six rougher cells, with the flotation concentrate reporting to the tailings thickener and the flotation product reporting to the product magnetic separator. The magnetic separator removes any free iron or magnetite present in the stream, with the product reporting to the product filters.

17.1.3 Fines Treatment (Low Grade)

The -1mm crushed fines will be subjected to gravity concentration on a series of spiral concentrators and shaking tables. The spirals will be configured in a rougher and scavenger arrangement, with the shaking tables serving as a cleaner. Concentrate will be added to the HG spiral middlings stream for treatment. LG shaking table middlings and tailings will be combined with the HG spiral tailings and reground in a closed circuit ball mill to 80% -106 μ m to liberate fine tin. The LG mill product will be gravity concentrated over another set of shaking tables, rather than an oxide flotation circuit as previously designed, with the concentrate being directed to sulphide flotation and the tailings reporting to the tailings thickener.

17.1.4 Filtration

The process has been modified to only produce a single product. Additionally, the type of filter employed have had to be modified owing to a change in the particle size distribution feeding the filter. The vacuum belt filter will produce a cake for bagging and dispatch with a moisture content of approximately 10% to 15%

17.1.5 Tailings

The tailings philosophy remains unchanged. Tailings from the fines spiral circuits and recovered water from the jigs will be dewatered in a thickener. Recovered water will be re-used in the plant.

Thickened tailings will be pumped to the TSF.

17.1.6 Services

Services will include reagent storage, make-up and distribution facilities, water storage and distribution and air.

17.1.7 Operation

The plant has a nameplate capacity of 360 000 t/a and will operate the crushing circuit 16hrs/7days and the wet plant 24hrs/7days, inclusive of scheduled maintenance.

17.2 TEST WORK

The process described in this document is the result of laboratory test work undertaken at Mintek and is supplementary to the original test work program. The latest campaign utilised left over sample from the previous test campaign, and is completely detailed in a Mintek test work report.

The testwork indicates that a tin concentrate of >60% tin can be achieved with an overall recovery of >80%. DRA along with the ABM's representative, have been involved in the testwork monitoring and management during the campaign.

Owing to potential plant inefficiencies, a process recovery of 73% with a grade of 61% tin has been specified for the economic evaluations.

17.3 PROCESS DESCRIPTION

The complete process design criteria can be found in DRA-C0216-PROC-DC-028. From a macro view point, the process consists of the following, with appropriate dewatering stages in between:

- Front end crushing and screening
- Coarse pre-concentration with jigs
- Several stages of milling and gravity concentration using spirals and shaking tables
- Sulphide flotation and magnetic separation to remove impurities
- Concentrate dewatering
- Tailings handling
- Reagents and services

17.3.1 Front End Crushing and Screening

Ore from the mine will be trucked to the ROM pad and either direct tipped into the ROM feed bin or tipped onto a ROM stockpile for reload by FEL later. The ROM material will then be withdrawn from the bin by apron feeder and through a jaw crusher, which will reduce the material from nominally -450mm to nominally -150mm. The jaw crusher product will be conveyed to the secondary crusher sizing screen, whose oversize will be conveyed to the secondary crusher feed bin, while the screen undersize will feed the tertiary crusher screen. The tertiary crusher screen will also be fed by the products on the secondary and tertiary crushers in a closed circuit arrangement. The tertiary crusher screen oversize will be conveyed to the tertiary crusher bin while the screen undersize will be conveyed to the plant feed stockpile. Under nominal conditions, all of the screening will be conducted dry, with the provision for intermittent wet screening capabilities on the tertiary crusher screen.

Material will be withdrawn from the bottom of the secondary and tertiary crusher bins by vibrating feeder, and will be directed through the secondary and tertiary cone crushers respectively. The secondary crusher will produce a product of nominally -32mm while the tertiary crusher will produce a product of nominally -8mm, both of which will be collected on a common conveyor and conveyed back to the tertiary crusher screen.

The crushing and screening circuit will operate on 5 200 hours annually and has a design throughput of 100 t/hr. The 1 900 tonne plant feed stockpile will serve as the buffer between the crushing circuit and the remainder of the plant, which will operate on 7 000 hours annually.

17.3.2 Jigs

-8mm material is reclaimed from the plant feed stockpile via FEL, a small plant feed bin and a belt feeder at nominally 52 t/hr and is conveyed to the rougher jig. The jig effects a density separation, with
Bisie Tin Project NI 43-101 Technical Report – 23 March 2017

the less dense reject material gravitating to the tailings dewatering screen and the more dense concentrate material gravitating to the cleaner jig. The cleaner jig also effects a gravity separation and the tailings is pumped back to the rougher jig while the concentrate is gravitated to the concentrate dewatering screen.

Both the jig concentrate and tailings is dewatered on a screen with a cut size of 1mm, with the combined -1mm slurry being pumped to the low grade gravity concentration circuit. The -8mm+1mm jig tailings, at nominally 37 t/hr, are conveyed to a tailings stockpile for reload by FEL onto trucks for disposal at the TSF and the -8mm+1mm jig concentrate is conveyed to the HG mill feed bin.

17.3.3 High Grade Gravity Circuit

Jig concentrate is withdrawn from the bottom of the HG mill feed bin at a controlled rate, nominally 4 t/hr, by weigh feeder and fed into the primary peripheral discharge ball mill. The mill circuit includes a sizing screen and produces a product with a p80 of 425 μ m which is pumped to the HG gravity concentration circuit. The high grade (HG) circuit is arranged such that a rougher spiral produces a concentrate and tailings, with the concentrate feeding a shaking table and the tailings feeding a scavenger spiral. The rougher shaking table concentrate ("HG gravity concentrate") is pumped directly to the product magsep feed tank due to its low contaminants and high tin values, and the shaking table tails are combined with the rougher spiral tailings and pumped to the scavenger spiral.

The scavenger spiral produces a concentrate which is gravitated to another set of shaking tables, and a tail ("HG gravity tails") which is directed to the LG regrind circuit. The shaking table concentrate ("HG gravity middlings") is gravitated to the HG regrind mill and the tailings is recycled to the feed of the scavenger spiral.

17.3.4 LG Gravity Circuit

The -1mm stream from the jig product and discard dewatering screens, nominally 13 t/hr, is pumped to a rougher spiral which produces a concentrate that is gravitated to a bank of shaking tables and a tailings which is pumped to a scavenger spiral. The scavenger spiral produces a tailings stream ("LG gravity tails") which is pumped to the tailings thickener and a concentrate stream which gravitates to the shaking table bank mentioned previously.

The low grade (LG) shaking tables produce a concentrate ("LG gravity concentrate") which reports to the HG regrind circuit, and a tails ("LG gravity middlings") which reports to the LG regrind mill.

17.3.5 Low Grade Regrind Gravity Circuit

The HG gravity tails along with the LG gravity middlings report to a regrind ball mill and screen, which produces a product with a p80 of 106 μ m. The stream reports to a bank of shaking tables which produce a concentrate ("LG regrind concentrate") that reports to the sulphide float feed, and tailings ("LG regrind tailings") which is pumped to the tailings thickener.

17.3.6 High Grade Regrind Circuit

The feed to the HG regrind circuit consists of HG gravity middlings and LG gravity concentrate. The mill circuit consists of a ball mill in conjunction with a screen and produces a product with a p80 of 106 μ m. The ground stream is then combined with the LG regrind concentrate and pumped to sulphide flotation.

17.3.7 Sulphide Flotation, Magnetic Separation and Filtration

Product from the HG regrind mill along with the LG regrind concentrate reports, via a 2 hour buffer tank, to a bank of conventional sulphide rougher flotation cells. The sulphide minerals, which are a contaminant in the final concentrate, are floated off with the froth while the material which did not float is combined with the HG gravity concentrate and pumped to the product magnetic separator. The magnetic separator removes any free iron minerals which may still be present along with any iron added to the stream during the various grinding stages. The magnetic separator tails are combined with the flotation froth and pumped to the tailings thickener while the magnetic separator concentrate reports to the product filter via a 2 hour buffer tank. The single concentrate stream is dewatered with a vacuum belt filter before being bagged and set aside for storage.

17.3.8 Tailings Thickening and Pumping

The various tails streams produced throughout the process is thickened and the water recovered. The various streams will be pumped and gravitated to a thickener feed box. After flocculant addition, the slurry will be gravitated to the thickener. Thickener underflow will be controlled by pumps which will pump tailings to the tailings disposal section. Thickener overflow will gravitate to the process water tank.

Thickener underflow is collected in a surge tank from where it is pumped to the TSF using either of two sets of parallel pumps. Two tailings lines to the TSF are provided.

17.3.9 Water Services

In the early stages, raw water will be pumped from a river to the raw water tank and later on, the excess water produced by the mine will be gravitated to the raw water tank instead. The water will then be filtered and pumped to the plant area to serve as level make up water in the process water tank, gland service water for the tailings pumps and make up water for the reagents. The water quality will be assessed, and if necessary treated to provide potable water for general use.

Thickener overflow water will gravitate to the process water tank, from where it will be distributed to the required process areas.

17.3.10 Air Services

An operational and standby air compressor will be used with associated filters, dryers and receiver to provide instrument and plant air.

17.3.11 Reagents

17.3.11.1 Flocculant

The required quantity of flocculant pellets are emptied into a hopper. From the hopper the flocculant will be fed by screw feeder to a wetting head and then to a mixing tank. After a suitable hydration time, typically two hours, the flocculant is transferred to a dosing tank. The flocculant is then pumped to the thickener.

17.3.11.2 Frother

Frother from isotainers is pumped directly from the isotainer to the required addition points.

17.3.11.3 Sulphide Collector

Xanthate pellets are weighed in the store and added by hand to the storage tank and diluted. The xanthate is then pumped to the sulphide flotation circuit.

18 PROJECT INFRASTRUCTURE

18.1 INTRODUCTION

The project site is accessible from Kisangani in the north and Goma in the east. The main ports available to the project are Mombasa in Kenya and Dar es Salaam in Tanzania. Access to the project site during construction and operation phase is planned by road from the east African ports. Air freight options are available into Entebbe, Uganda, but have not been considered for capital or operating cost estimates.

An access road from the Bukavu-Kisangani national road (N3) has been constructed from the village of Logu to Bisie, making the mine site accessible by road. The national road infrastructure is poor and rehabilitation works of approximately 45km are required on the Goma road.

The project site is well-established with first aid clinics, offices, staff accommodation, messing facilities, core storage and power generating facilities. Cellular telephone and internet services provide the site with communications to the outside world.

The proposed infrastructure will support the mining, concentrator plant and construction operations and can be summarized as follows:

- Infrastructure for health, safety and security such as advanced life support facilities, fixed wing aircraft landing strip, security control room, digital radio communications and clinic for workers minor ailments;
- Infrastructure for underground mining operations such as workshops, explosives magazines, fuel storage, lamp room, mine rescue brigade, compressors, potable water, service water and offices have been allowed;
- Enabling infrastructure such as logistics depot, mine access, diesel storage, water treatment, power generation equipment, sewage treatment, and workers camp accommodation; and
- Infrastructure for dealing with waste streams such as tailings storage facility, waste rock dump and non-hazardous refuse disposal.

This section details the facilities that are envisaged for the project. The site layout below shows the position of the mine RoM pad, infrastructure and concentrator plant relative to each other and the surrounding topography.

Figure 18.1 3D site layout view

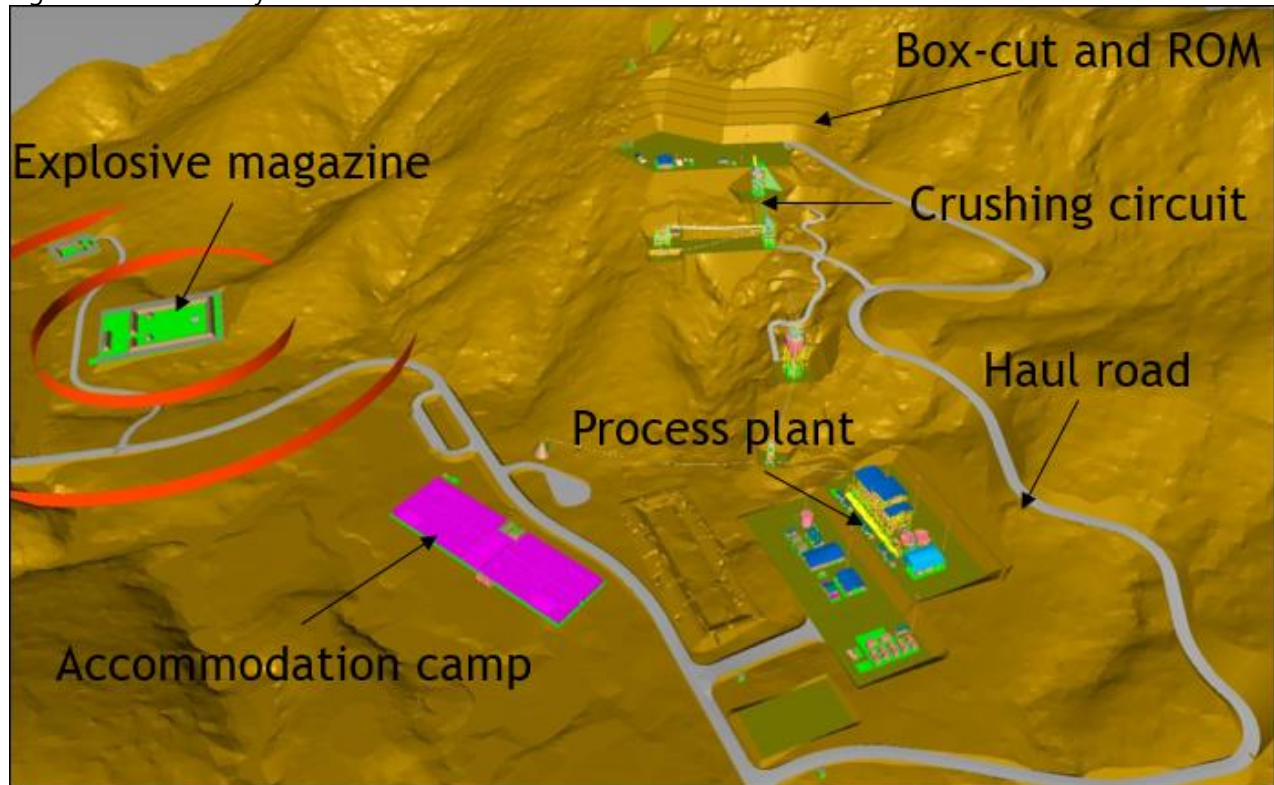

18.2 HEALTH, SAFETY AND SECURITY INFRASTRUCTURE

18.2.1 Occupational Health

A clinic will be constructed in the accommodation camp for the treatment of workers common ails and sicknesses. The clinic will be staffed with qualified medical personnel and be equipped to undertake annual medical examinations.

For more serious accidents or cases of medical emergency a containerised advanced life support facility has been planned. The facility will be manned on a 24-hour basis and will be able to stabilise employees prior to medical evacuation to Goma or other east African medical facility (by air);

18.2.2 Emergency Evacuation

A fixed wing airstrip is under construction approximately 8km from the mine site. This facility will primarily be used to transport staff from Goma to Bisie but has the secondary benefit of providing medical evacuation facilities in the event of a life threatening accident at the mine. Employees will be able to reach Goma within 30-minutes flying time. More serious cases can be transferred direct to Kenya within 5 hours.

18.2.3 Security

Alphamin has developed a detailed security management plan. This is set out in further detail in 24.2. Regarding the infrastructure required to execute the plan, allowance has been made for fencing, lighting, closed circuit television monitoring and state of the art digital radio networks to provide coverage across the project area and access road.

A centralised control room is planned at the main office buildings to coordinate the security management initiatives. Static guard posts have been located at strategic positions and will be supplemented by a mobile back-up force.

18.3 MINING INFRASTRUCTURE

The infrastructure at the portal is located over 3 terraces, to suit particular requirements and layouts.

Figure 18.2 Mining Infrastructure

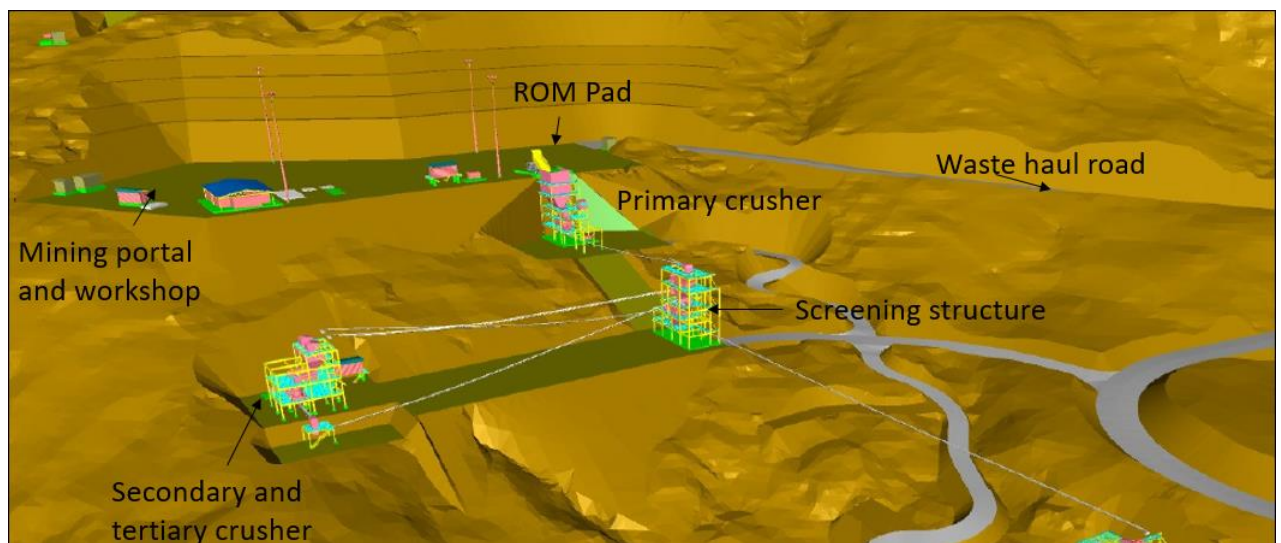

These terraced areas are:

- The portal terrace, where the primary mining surface infrastructure and access decline portal are located.
- The secondary and tertiary crushing and screening operations; and
- The mill feed silo.

18.3.1 Underground Access and Security

A security fence will be constructed around the perimeter of the terraced mining areas to secure the facilities. Access to the mining terraces will be via the haul road from the plant site and controlled by the security office at the main gates. Vehicles will be permitted access to the terraced areas through the gates, with personnel access being limited to a turnstile system.

The portal entrance will be secured to vehicle and personnel access to the underground workings. The access system operates in conjunction with the movement of personnel through the lamp room and is electronically controlled by means of unique identity recognition tags, which is monitored from the control room.

Parking for light vehicles will be located outside of the portal terrace fence, near the security office.

18.3.2 Mine Offices

Offices for the mining contractor personnel are located on the terrace portal area. These personnel will be responsible for day-to-day management of the underground mine.

18.3.3 Lamp Room and Crush

The containerised lamp room, control room and first aid building at the portal entrance comprise three essential facilities:

- The lamp room, holding racks of cap lamps and self-contained self-rescuers (SCSR), gas detection devices and a lamp repair bay;
- The portal control room, for the monitoring of underground vehicles and emergency situations;
- The first aid station, where basic medical care can be administered to personnel located at or near the terraces and underground.

The entry into and exit from the building is controlled using turnstiles and monitored specifically to account for personnel presence underground.

18.3.4 Daily Stores

A containerised daily stores facility will be provided at the portal terrace area, for holding and issuing consumable and routine spares items which are generally required on a daily basis to support the underground mining and equipment maintenance activities. This store will be supplied via the main stores.

18.3.5 Mining Equipment Workshop

The mining equipment workshop will be established on surface near the portal entrance. The workshop has been designed to accommodate the planned mobile underground fleet and includes provision for carrying out the following activities:

- Vehicle and equipment inspection, cleaning and servicing;
- Mechanical repairs;
- Boiler making and fitting;
- Electrical repairs;
- Hydraulic component repairs and replacement hydraulic hose assemblies; and
- Tyre changing and repairs.

18.3.6 Fuel Dispensing and Storage

The fuel storage and dispensing facility is located on surface at the portal terrace area. The facility comprises above surface storage tanks and dispensing. Diesel supply to the portal storage facility will be from the bulk fuel storage facility at the plant.

18.3.7 Oil Storage and Handling

Small quantities of new and used oil and old oil drums will be stored in the vicinity of the workshop. Old oil will be returned to the bulk storage facility for further handling and disposal.

18.3.8 Oil removal and separation

An oil separation and rope skimmer recovery system will be installed near the workshop to remove hydrocarbons from the run-off and wash water collected from the workshop, fuel dispensing and oil storage areas.

18.3.9 Services

- Potable Water will be stored and supplied from the main plant;
- Compressed air will be supplied to the underground refuge bays and the trackless workshop from compressors located on surface;
- Service water will be provided to the underground mining activities from a lined pond;
- Fire water will be supplied from a Braithwaite storage tank located above the mining portal;
- Dirty water from the mine will be pumped to lined settling ponds which will be cleaned out from time to time by manual labour.

18.4 ENABLING INFRASTRUCTURE

The enabling infrastructure will include the following:

- Logistics depot and diesel storage facilities
- Operations management facilities
- Electrical power generators
- Workers accommodation camp
- Communications
- Access road

18.4.1 Logistics Depot and Diesel Storage

A logistics depot has been established at the Logu office facility, located at the intersection of the Bisie access road with the Bukavu-Kisangani national route. The Logu logistics depot will allow ABM to receive deliveries in bulk (20-30t loads) from the east African ports to a position 35km from the mine. The bulk loads will be broken into smaller loads for the final transport leg on the Bisie access road. This break in bulk is required due to the steep gradient on the Bisie access road which requires four wheel and six wheel drive vehicles for traction.

Storage for 320,000 litres of diesel has been planned at Logu, with a further 320,000 litres planned storage at Bisie. Monthly forecast diesel consumption is 650,000 litres.

18.4.2 Operations management facilities

- Sewage and Water Treatment Plants - Sewage from the workers camp, plant and office ablutions will report to a sewage treatment plant for purification. Treated water will be re-used in the process plant and mining operations. Water abstracted from the local streams will be treated in a potable water treatment plant and piped to locations at the workers camp, offices, plant and mining operation for human consumption;
- Access control – 6m containers will be converted into security offices and equipped with turnstiles for access control and monitoring of time and attendance;
- Plant control room - a dedicated plant control room is to be located in a container arrangement. The control room will house the SCADA system and provide operators with a view of the plant;
- Plant Workshop - a suitable workshop with an area of 480 m² will be established adjacent to the process plant to enable repair of plant equipment. The workshop will be a steel frame building equipped with a 3 tonne overhead crane and will have bays for servicing light vehicles. The workshop will have separate areas for mechanical and electrical repairs. Provision has been made for oil separation of any water leaving the facility. Offices for supervisory, workshop store, maintenance and planning personnel will be provided in the form of a modular building situated adjacent to the workshop;
- Operations management buildings – this will be of a single-storey brick construction. The building will include general areas for the operations management team, mineral resource management team, process plant team and maintenance team. The non-production support functions of administration will be housed at the Logu facility;
- Laboratory - a laboratory capable of handling 50 underground mining samples and 100 process plant samples per day has been allowed. This laboratory will be capable of conduct all of the onsite analysis required for the processing plant operation and mine grade control activities;
- Medical facilities -
- Storm water dam - the design of this facility is based on handling a 1:20 year storm event;
- Fire system - The fire water system consists of a header tank with dedicated jockey pump. Fire water lines will be run to conveyor pulleys and areas of high fire risk identified in the plant. In addition, portable fire extinguishers will be housed within the process plant facilities and the mine accommodation camp.

18.4.3 Workers Accommodation Camp

The camp will provide accommodation suitable for housing 500 - 700 persons during both the construction and the production phases. This camp includes the following infrastructure:

- Kitchen and camp dining room.
- Entertainment area including a gym.
- Laundry.

- Sewerage disposal plant.
- Security building.

The mine accommodation camp is designed to house junior staff in 20 man dormitories and twin shared senior staffing accommodation. Materials of construction will include corrugated roofing and locally sourced timber. Flooring will compile of a locally mixed cement and soil combination.

18.4.4 Communications

Communications will be via a dedicated satellite link internet service. Cell phone masts have been established and communications with site via telephone is good.

18.4.5 Access Road to Site

The project site is accessible by road from Goma.

The road from Goma to Walikale is approximately 220km and is in poor condition due to poor maintenance of the drainage infrastructure and high annual rainfall. Alphamin has concluded an agreement with the Provincial authorities to assist in the upgrade of the Goma-Walikale road. This assistance is granted together with assistance from NGO's and MONUSCO who use the road for security patrols and food distribution efforts. Ongoing maintenance of the road once it has been rehabilitated will fall under the responsibility of FONER and will be funded through toll collections managed at Provincial administration level.

The road from Walikale to Logu is approximately 60km. The road is in reasonable condition and from Walikale, vehicles have the option in the dry season of travelling to Bukavu by road.

Alphamin has constructed an access road from Logu to Bisie. This 32km route has been constructed using available road building materials. Use of the road in wet conditions is difficult and Alphamin plans to upgrade this road with formal layer works once a crusher has been established on site. Further detail on site access is provide under 24.3.

18.4.6 Power Supply and Distribution

Power shall be supplied from a light fuel oil (LFO) diesel power station at 400V distribution voltage. Overhead cables shall link the diesel power station to the process plant and mining operations. The diesel power station has been designed on a modular basis, each module being made up of a 1.2MVA generator, with three generators in the initial capital footprint. The ultimate installed power will require 5 generators operational with allowance made for one standby unit.

18.5 MINE RESIDUE STORAGE

Three streams of mine residue (or waste) reporting from the Process Plant and the mine, require storage within the licence area. The residues requiring storage are:

- Waste rock from the underground mining works, trucked to site;
- Slurry Tailings (Spiral Tailings) (<1mm) hydraulically pumped from the Process Plant; and
- Coarse, Dry Tailings (Jig Tailings) (1-10mm) trucked from the Process Plant.

A full report on the mine residue storage facilities is detailed under Section 24.4.

18.6 WASTE CONTROLS

Industrial and domestic waste will be recycled where practical. A domestic refuse disposal facility has been laid out adjacent to the waste rock dump and will be managed on a day-to-day basis by Alphamin.

Used engine oil will be filtered and bled into the diesel used in the diesel power station at levels acceptable to the OEM specifications.

19 MARKET STUDIES AND CONTRACTS

19.1 TIN MARKET ANALYSIS

This report is based on the eleventh annual survey of tin users carried out by ITRI. 148 companies took part in the exercise, accounting for more than 46% of estimated total world refined tin use last year.

The evidence collected points to a contraction in demand during 2015 and it is estimated that global refined tin use will fall by a little over 3% in 2015 and is likely to remain at about the same level in 2016. This contraction in demand comes on the back of a 2.7% increase in demand in 2014, slightly above the long-term trend increase rate of 1.9% per year. The main applications contributing to growth were tin chemicals, lead-acid batteries (mainly in China) and copper alloys.

The dominant negative factor in 2015 is the slump in China’s solder industry. It is estimated that the aggregate refined tin use in solder in China declined by 10% this year. This estimated drop of more than 10,000 tonnes in volume terms accounts for almost 90% of the decline in world demand this year. Outside China, tin usage remained stable in 2015 and these companies are forecasting further growth in 2016, notably in solder and chemicals. A more detailed analysis of trends and expectations by application follows below.

19.1.1 Tin Use by Sector

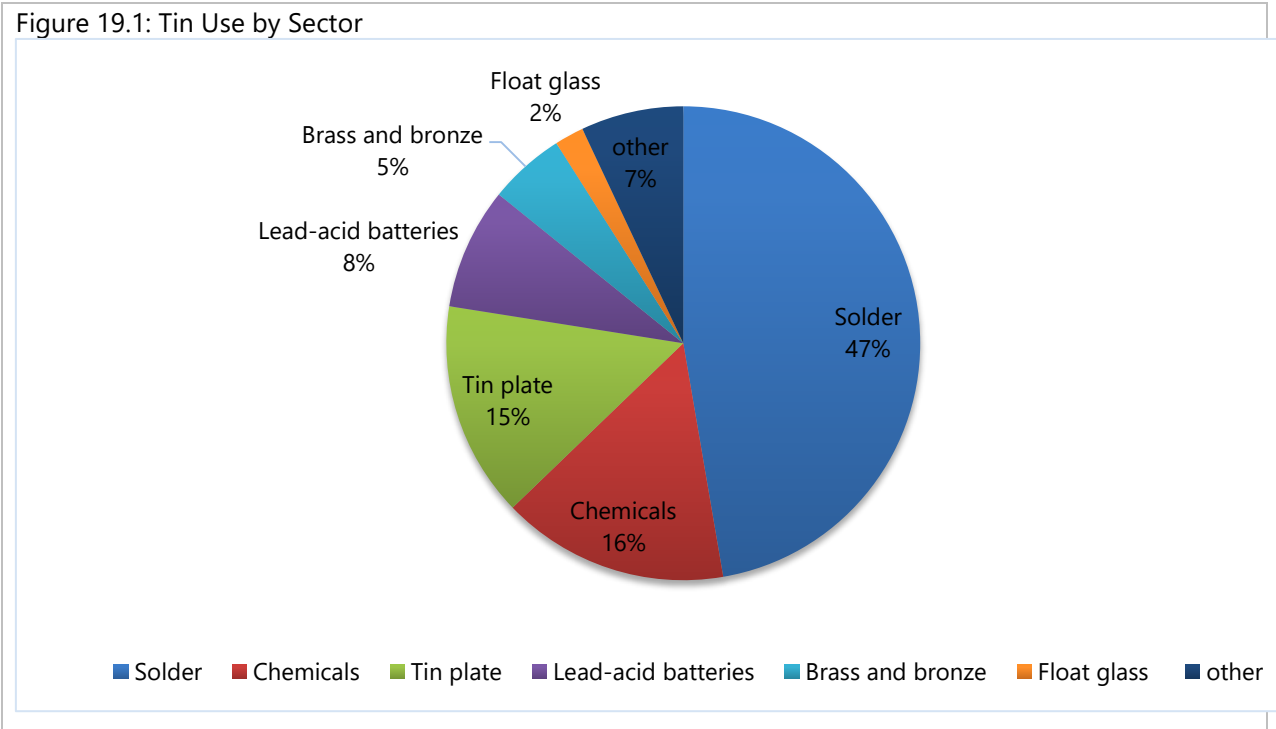

Source: ITRI 2015 Tin Use Snap Survey

19.1.1.1 Solder

Tin is the primary component of both leaded and lead free varieties of solder used in electronics and continues to be the top use for the metal, representing broadly half of global consumption.

The total tin usage in the sector in 2014 was 173,400 tonnes in 2014. For 2015, annual consumption is expected to fall 5.4% to an estimated 164,000 tonnes. Looking forward to 2016, global tin consumption in solders is forecast to fall a further 1.9% to 160,900 tonnes.

The long term outlook for solder usage remains balanced, with growth in electronics and further conversion to lead-free solders in high reliability applications, such as aerospace and military, offset by smaller unit volumes as a result of miniaturisation.

19.1.1.2 Chemicals

Tin use in chemicals overtook tinfoil as the second largest tin application in 2014 and looks likely to retain this position for the foreseeable future. Important tin chemical applications include PVC stabilisers, polyurethane foam manufacture and glass coatings.

The total tin usage of the sector in 2014 was 55,700 tonnes in 2014. For 2015, annual consumption is expected to fall 2.0% to an estimated 54,600 tonnes. However, in 2016, global consumption is forecast to more than recover this loss with expected annual growth of 2.6% to 56,000 tonnes.

Larger suppliers in China increased production of some specific tin chemicals in 2015, including plating chemicals and PVC stabilisers, but overall, sustainability issues and a poor national economy are severely constraining tin use there. Markets for plastics, the largest use of tin chemicals, are shifting outside China to South East Asia, and prices for tin PVC stabilisers in China have dropped sharply. Some Chinese producers are also setting up new production in South East Asia. Key traditional end-use markets such as plating and ceramics are in decline, with an expectation that this may worsen in 2016. Replacement of lead PVC stabilisers in China is a positive driver, but European markets for polyurethane catalysts and PVC stabilisers will continue to decline as some tin products are phased out over a perception of environmental concerns.

19.1.1.3 Tin Plate

Tinfoil, primarily used in food and beverage cans, is a very traditional market for tin, which functions as a corrosion protector in the material. Until recently, tin use in the sector has remained largely stable, with little change over the last decade.

Total tin use in this sector was 52,600 tonnes in 2014. For 2015, annual consumption is expected to contract 4.2% to an estimated 50,400 tonnes. Looking forward to 2016, global consumption is forecast to contract again, though by a far more modest 0.4%, to 50,200 tonnes.

The downturn in the national economy coupled with over-capacity domestically has strongly impacted the tinfoil market in China in particular. Tin waste minimisation in production has had a negative net effect on tin consumption. Continued competition from aluminium beverage cans and other alternative competitive packaging materials are also making inroads into this traditional market. In the United States, tin coating weights increased due to the introduction of BPA-free lacquers in food cans.

19.1.1.4 Copper Alloys

Tin and copper are traditionally combined to produce bronze, but tin is also added to other copper based alloys such as brass. Tin use declined in 2008 at the time of the economic crash but has generally been rising steadily since.

Total tin use in this sector was 18,700 tonnes in 2014. For 2015, tin use in copper alloys is expected to remain unchanged but is forecast to fall 1.1% in 2016 to 18,500 tonnes

The use of tin in bronze and brass (predominantly bronze strip/sheet) used in electronics applications is most susceptible to the fluctuating global economy and thus it is easy to speculate that current economic uncertainty surrounding weak growth in Europe and the Chinese slowdown will have an impact upon the sector.

19.1.1.5 Others

All uses of tin not part of the four aforementioned tin market sectors are included under this heading. Lead acid batteries are now by far the biggest component of the "Others" category. Other relatively minor applications covered include tin powders, wine capsules, tinned wire, pewter and bearing metals.

The manufacture of lead acid batteries accounted for 26,000 tonnes in 2014 with other applications accounting for 32,000 tonnes. For 2015, these applications are expected to increase by 1.72% to 59,200 tonnes and by a further 3.55% in 2016 to 61,300 tonnes of tin consumed.

The outlook for tin use in lead-acid batteries appears positive. Tin use in this application has been boosted by a regulated shift from antimony-cadmium alloys to calcium-tin products. There was also growth in stationary batteries for alternative energy and telecoms. Some short-term negative impact from lower automotive sales is expected to reverse in 2016, especially for new 'start-stop' vehicles. Substitution by lithium ion batteries is already underway, especially in e-bikes, and this will slow growth going forward. A 4% lead consumption tax from early 2016 will impact profitability.

Aside from lead-acid batteries, another positive feature in the smaller applications is the revival of the tin capsules business in the wine and spirits market. This is one of the most price-sensitive uses for tin and the peak in tin prices in 2011 resulted in a major loss of market share to cheaper competing materials such as aluminium and plastics. However, from a low point in 2012, tin usage has recovered by some 25% in 2015.

19.1.2 Tin Supply

China and Indonesia have long histories as major tin producers, but despite substantial reserves it may not be possible for them to sustain output at recent rates. This means that additional supplies to meet future growth in demand will come from other parts of the world. The very large shares of world production those two countries now account for have only been achieved since the 1990s.

Up to the mid-1980s Malaysia, Bolivia and Thailand were also major producers. For example, the cumulative production from Malaysia since 1950, at over 2.45 million tonnes, is only slightly less than that of China (2.7 Mt) and Indonesia (2.6 Mt). The other million tonne plus producer has been Bolivia, with 1.38 Mt since 1950. Bolivia remains a significant producer today, but in Malaysia and Thailand tin mining is now subservient to the needs of the manufacturing and leisure sectors. The two other countries that have figured at times as leading producers have been Brazil and Peru. Brazil briefly became the world's largest producer in the late 1980s, while Peru became a significant supplier in the 1990s.

In recent years artisanal and small-scale mining has accounted for as much as 60% of world production, although this share has now dropped to a little below 40%. The main centres of artisanal mining have been Indonesia, China, Bolivia and Central Africa. However depletion of ore deposits, especially

onshore, is expected to result in a continuing decline in Indonesian production, while Central African tin, principally from DR Congo, has experienced political controls on the trade in conflict minerals.

Taking into account the re-use of recovered tin alloys, notably solders, brass and bronzes and lead alloys, secondary materials contribute over 30% of total tin use in any typical year. These alloys can be re-used without the need for re-refining to pure tin. However there has also been recent growth in secondary re-refined tin production which has exceeded 50,000 tonnes in each of the last five years, equivalent to around 16-17% of total refined metal production and amounted to over 65,000 tonnes in 2014. Tin can be easily recycled with no loss of quality with secondary material refined to high purity grades. Currently 98% of global mine production occurs in developing countries, providing livelihoods, export earnings and opportunities for future infrastructural and other forms of development.

19.1.2.1 Production Trends 2015

The tin supply situation has been characterised by an overall decrease in supply. This has been led by significant decreases in output from traditional tin producers such as China, Indonesia and Peru. The decrease in production from these sources has been supplemented by a significant increase in production from Myanmar.

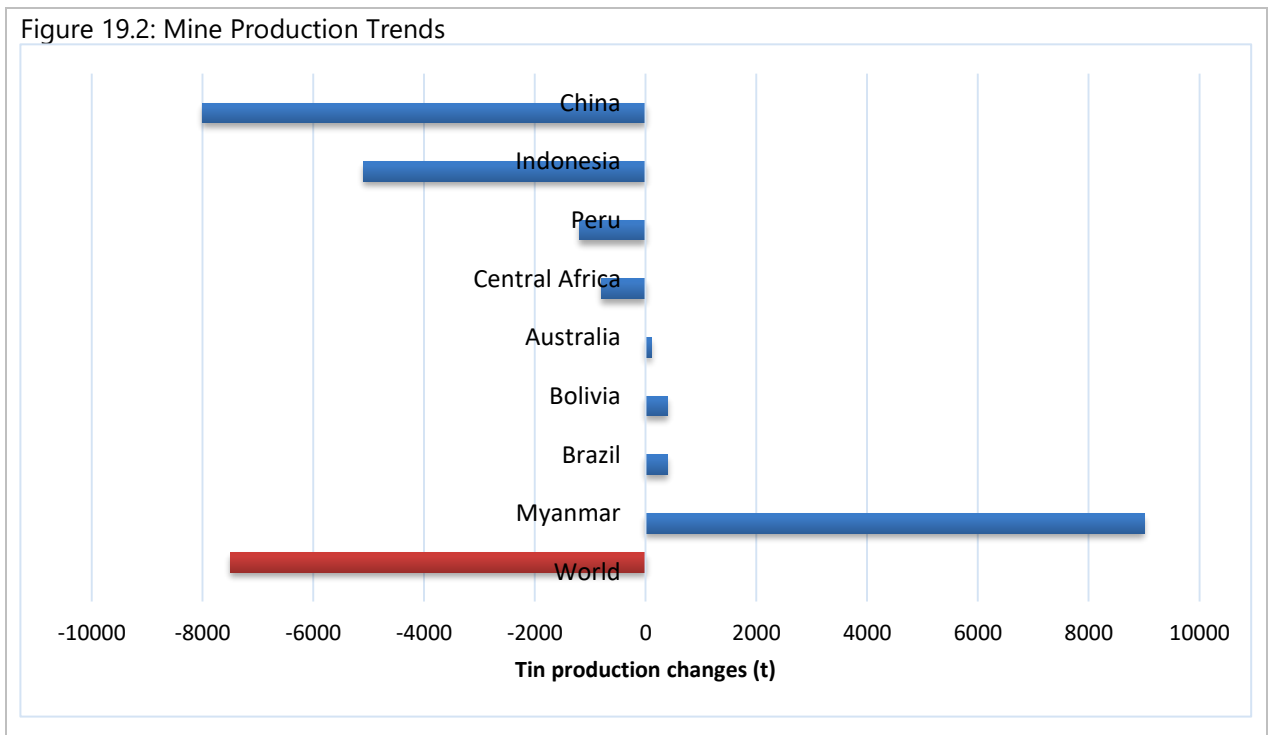

Source: ITRI 2015 Tin Use Snap Survey

19.2 SUPPLY AND DEMAND BALANCE

In November 2015, ITRI published the following supply and demand data.

Table 19.1: World Supply/Demand Balances in Refined Tin

	Units	2009	2010	2011	2012	2013	2014	2015	2016
World refined production	kt Sn	339.7	354.6	354.3	334.7	340.1	369.1	340.6	336.8
World refined use	kt Sn	323.3	362.2	359.4	339.4	349.1	358.5	346.9	346.9
Global market balance	kt Sn	17.4	-7.6	-5.1	-4.7	-9.0	10.6	-6.3	-10.1
Reported stocks	kt Sn	66.4	48.3	46.7	39.5	34.3	39.1	32.5	26.0
World stock ratio	Week	10.7	6.9	6.8	6.0	5.1	5.7	4.9	3.9

Looking further into the future, ITRI have forecast the gap between supply and demand to increase further due to a lack of incentive for producers to invest at current tin price levels.

Figure 19.3: Forecast Production/Consumption Estimates to 2020

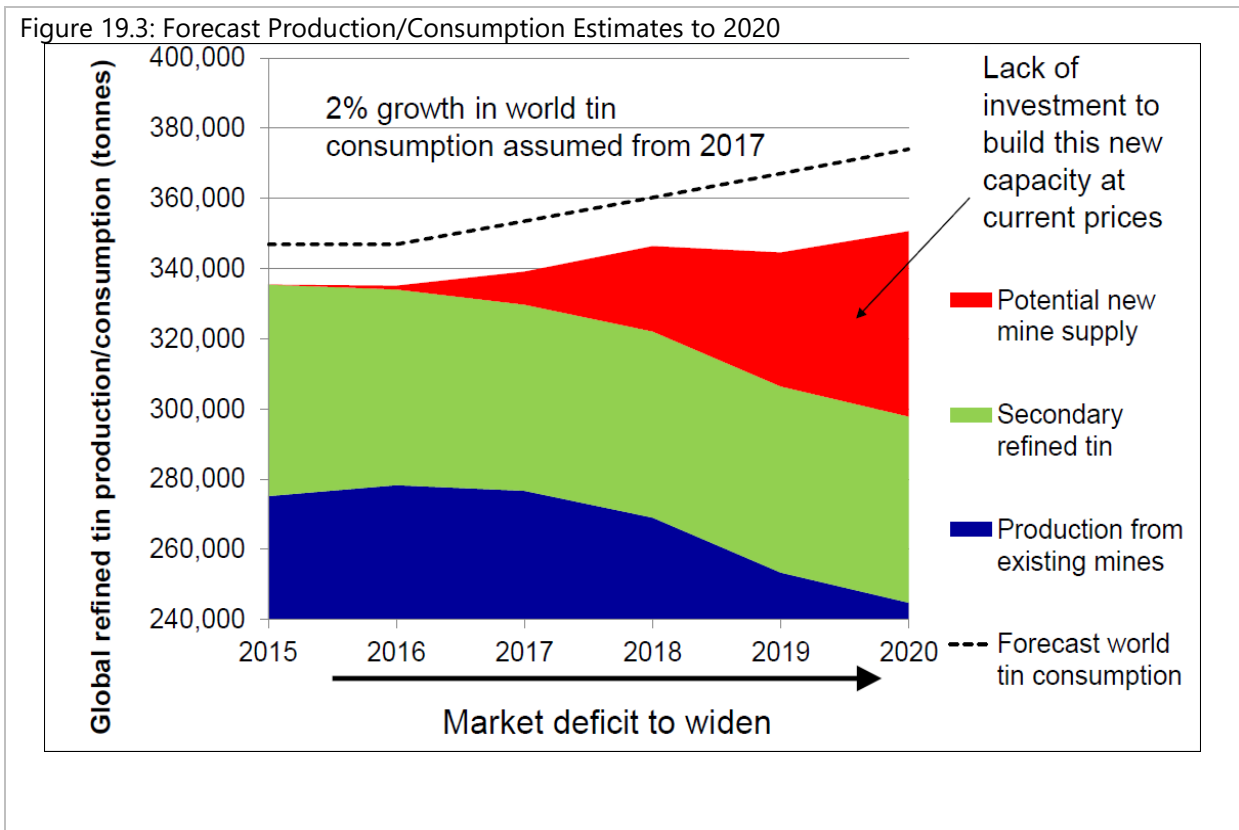

Source: ITRI 2015 Tin Use Snap Survey

19.3 FORECAST TIN PRICE

In determining the forecast tin price, data from the International Tin Research Institute (ITRI) was used as follows.

Figure 19.4: Cumulative Cost Curve for Worldwide Tin Production

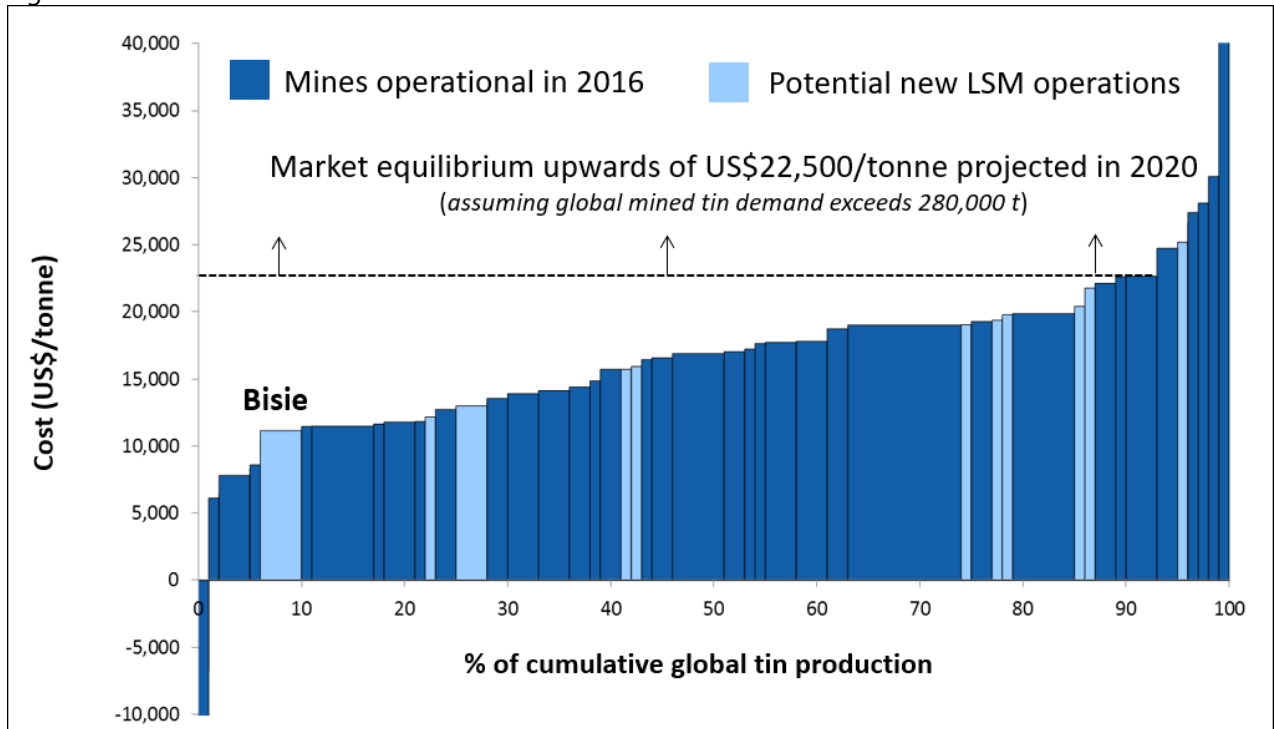

Source: ITRI Tin Market Briefing (Q2 2016)

This forecast tin price used by Alphamin is \$21,400/t Sn over the life of mine.

19.4 MARKETING CONTRACT

Over the past 18-months, Alphamin has issued a request for enquiry into offtake terms for its tin concentrates to established contract smelters and tin traders. The proposed terms offered have been adjudicated and discussions held with smelter operators on treatment charges, penalties associated with impurities and marketing costs.

Applying the terms offered by a well-established tin trader, treatment charges of US\$1,555 and marketing commissions of \$577 per ton Sn in concentrate will apply.

20 ENVIRONMENTAL STUDIES, PERMITTING AND SOCIAL IMPACT

20.1 ENVIRONMENTAL PERMITTING

As part of the process of converting the Permis de Reserches (exploration license) into Permis de Exploitation (mining license), Alphamin submitted its Environmental and Social Impact Assessments and Management plans to the Cadastre Minier for approval. The plans have been reviewed and approved by the relevant authority and as such, the Project has full environmental permitting for construction and operation.

In terms of the Mining Regulations, compliance with the Environmental and Social Management plans is scheduled every 2 years and the next audit will take place in February 2017.

20.2 BIOPHYSICAL ENVIRONMENT

20.2.1 Terrestrial Ecology Of The Study Area

The vegetation surrounding the project site is typical of the Guinea–Congo Forests biome vegetation and is covered by dense terra firma forests with varying composition and structure depending on altitude. The project site exhibits plain (lowland) forests, which extend up to an altitude of 1,000 m, with mixed vegetation of *Strombosia* and *Parinari* and a monodominance of *Gilbertiodendron dewevrei* and *Staudtia kamerunensis* which comprise the gallery forests in the area. Despite the years of ASM activity in the area, much of the vegetation close to the project site is still comprised of relatively undisturbed, primary forest. In addition there are areas of relatively intact forest but which now form isolated patches which are surrounded by areas which have been highly impacted by the previous mining activities. The site can be categorised as follows:

20.2.1.1 Primary Forest – High Sensitivity areas

Typical terra firma primary forest, which is well represented in the project site, can be divided into four recognised communities (Fischer 1993). However, only three of these are found on site as the fourth community is restricted to altitudes over 1200 mamsl; the highest point in project site being around 850 mamsl. These high sensitivity areas consist of the following -

- **Gilbertiodendron dewevrei Community:** This rainforest type is characterized by the dominant *Gilbertiodendron dewevrei* in tree and shrub layers. The tree layer may well reach 40 m. The herb layer consists of dominant Rubiaceae (*Stipularia*, *Geophila*), Acanthaceae and Marantaceae. Some remarkable species belong to the genus *Impatiens*, among them the epiphytic *Impatiens irangiensis* and *Impatiens paucidentata*. The *Gilbertiodendron*-community is frequent between 850 and 1100 m elevation.
- **Uapaca Community:** Mainly near rivers and streams. Water-tolerant forest communities are characterized by *Uapaca* species. The *Uapaca* community can be observed up to 1000 m elevation.

- Julbernardia-Cynometra Community:** This forest type is characterized by the dominating Julbernardia sereti and Cynometra alexandri. Gilbertiodendron shows only a scattered occurrence. Other typical species are Piptadeniastrum africanum and Anthonota acuminata.

20.2.1.2 Isolated Forest Areas – Medium sensitivity

A majority of the vegetation on the project site is either intact primary forest or has been cleared in recent years. There is however a small area of intact forest on the western slope of the exploration camp hill which is now isolated and cut off from the main forest areas and therefore its ability to act as prime habitat and its ecosystem function is slightly diminished. It has therefore been classed as being of medium sensitivity.

20.2.1.3 Impacted Areas – Low Sensitivity

Areas which have been cleared either during the previous mining activities or for cultivation purposes are easy to identify from ABM sourced LIDAR and satellite imagery. A majority of the cleared areas are towards the south of the project site and close to Manoire village (Figure 4.1). Some of the cleared areas were cut and cleared to make space for the cultivation of subsistence crops such as plantains/bananas, millet and pineapples. There is evidence that areas have been cleared within the past few months and after burning off most of the fallen leaf material, cassava is being plants between the dead tree trunks.

Since the cessation of artisanal mining activities some of the cleared areas have seen re-growth of forest vegetation. This is evident from the presence of the dominant pioneer species Uapaca quinensis.

Figure 20.1: Sensitivity analysis of the study area vegetation

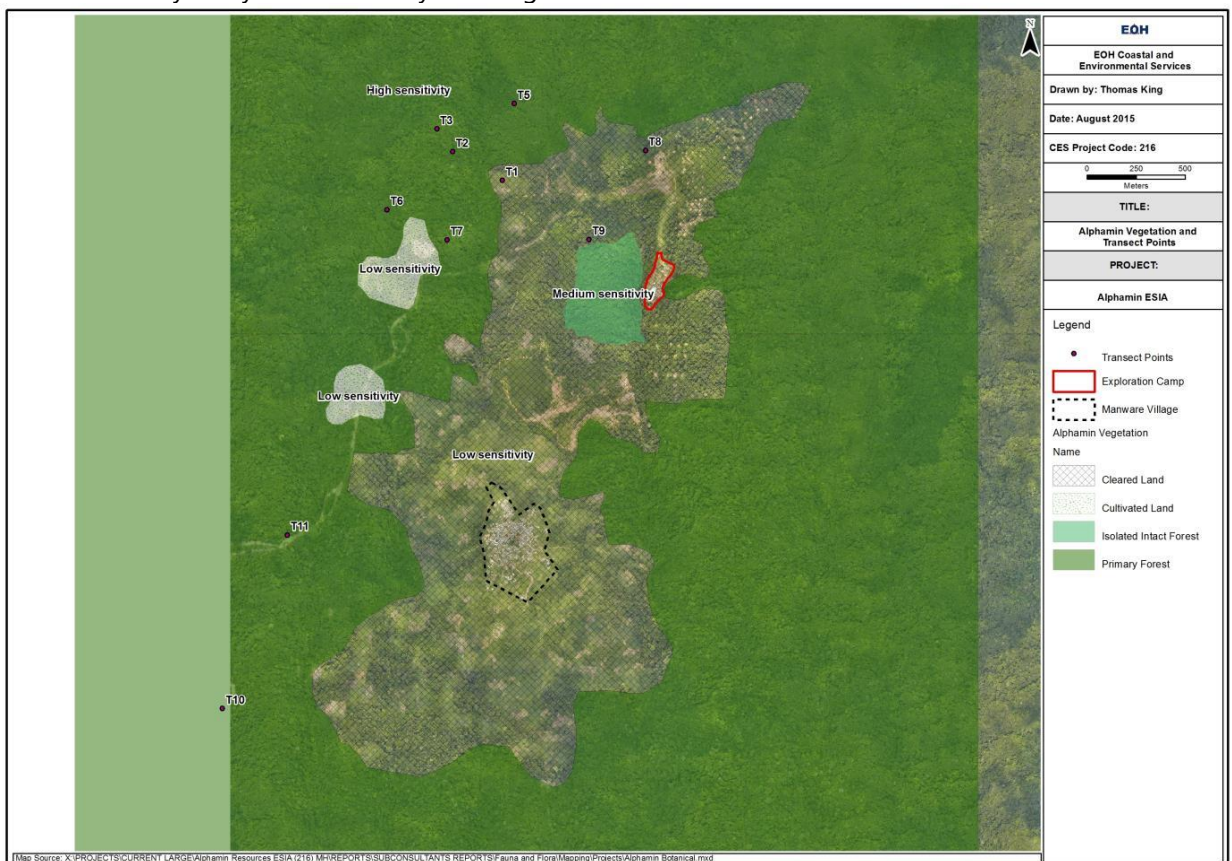

There are very few faunal species, especially mammal species, in the project area. The only mammal species observed were three Bush Squirrels, (*Paraxerus* sp) which were found in the cut vegetation along the path cleared for the access/haul road. In addition, the fresh footprints of a Genet of undetermined species were seen in the mud next to the Bisie River.

The study area is only 15km from Maiko National Park (NP) which is a known sanctuary for three of the country's endemic animals: the Grauer's gorilla (*Gorilla beringei graueri*), the okapi (*Okapia johnstoni*), and the Congo peafowl (*Afropavo congensis*). Maiko is also an important site for the conservation of the African forest elephant, eastern chimpanzee and the endemic aquatic genet.

Historically the project site would have been inhabited by a wide range of faunal groups and species. However, reports from the local communities indicate that most of the resident mammal species have been hunted out in recent years by rebel groups, poachers and local hunters. At the height of the ASM activity when 15-18,000 people lived in the project area, the demand for bushmeat would have been extremely high.

Recent reports from staff at the exploration camp say that there have been no sightings of any gorilla or chimpanzees in the area for the last 6 to 7 years although recently (2015) a small number of monkeys of unknown species have occasionally been seen in the Bisie River valley but they remain very wary of humans.

The only reptile observed during the survey period was the forest hinge-back tortoise - *Kinixys erosa* which was observed in the isolated forest area on the western slope of the exploration camp hill. Reports also indicate that tortoises are regularly eaten by the local communities and that finding live tortoises close to human inhabited areas is becoming a rare event. This tortoise species is not considered threatened by IUCN.

As bird populations tend to be less impacted by human activities the diversity of birds in and around the project site is high. 784 bird species have been recorded in the North Kivu province of which 23 are considered globally threatened and five are introduced species. 335 species have been recorded in the Kahuzi-Biega NP, which lies south of the project area but which is biophysically similar to the project area, of which 29 are endemic and 7 are listed as globally threatened. Although many of the forest birds inhabiting the forest around the project area tend to be secretive and are only identified by their calls, 43 species were identified from the project site.

While some of the birds observed were eastern Congo endemics, the only globally threatened species observed was the African Grey Parrot (*Psittacus erithacus*) which is listed as Vulnerable by the IUCN.

The aquatic fauna of this ecoregion is incompletely known; data is particularly scarce for fishes, reptiles, and aquatic invertebrates. Fish richness appears to be low, with only 16 described species (G. Teugels, personal communication). However, the waters of this ecoregion are poorly sampled and further investigation will probably reveal multiple new species.

20.3 SOCIO-ECONOMIC ENVIRONMENT

The term Project-Affected Community (PAC) is used to refer to a community which is affected by the project either from primary (i.e. direct) or secondary economic or social effects (i.e. further spin-off effects), but also from a livelihood perspective. The term PAC is further defined according to the type of impact (either direct or indirect) the project will have on the particular community. Directly affected

Bisie Tin Project NI 43-101 Technical Report – 23 March 2017

communities are generally located in close proximity to the project area, whereas indirectly affected communities are generally several kilometres (and further) away. In this context, a direct PAC would refer to those villages inside the corridor of impact, which could be affected by indirect impacts (e.g. trade and commerce and related demographic and livelihood changes) and, directly from the physical activities of the project itself. For example, they might be physically or economically displaced as a result of a projects 'land take' requirements, or might be close enough to the project activities to be affected by them. Being on the periphery of the current exploration area, Manoire village is considered to be the most directly affected PAC by virtue of being the only settlement close to the mine site.

The Figure below depicts the single direct (Manoire) and numerous indirect PACs (the remainder), and also illustrates the settlements canvassed during the socio-economic baseline survey. This is an ASM settlement that has been in existence since mining commenced on site in early 2004 and is not a historic settlement. Manoire residents rely heavily on natural resources within the project's study area, as well as the import of basic foodstuffs from towns like Walikale and Osakari.

Figure 20.2: Project-Affected Communities (PACs) in the Study Area

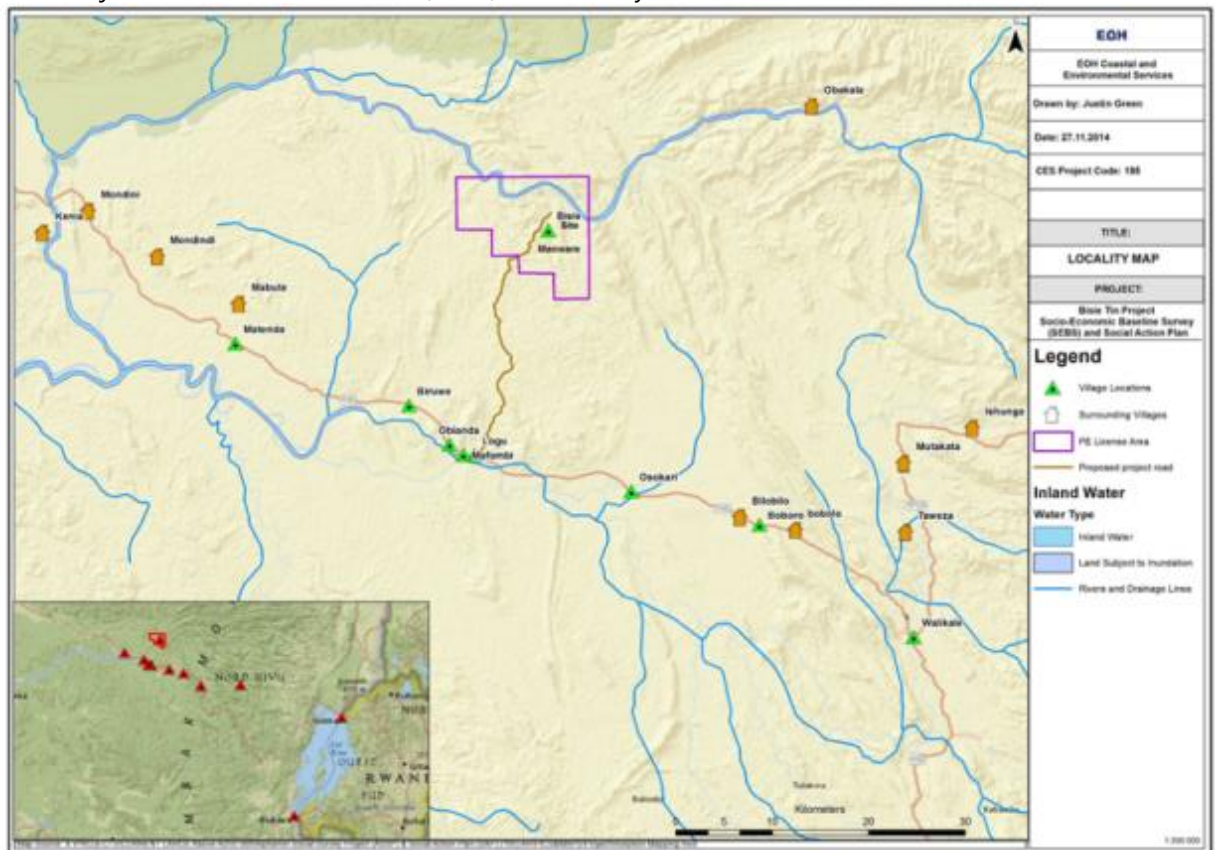

Indirect PACs include larger towns and villages especially along major road networks such as Logu, Walikale and Osakari. They are affected by secondary social or economic impacts, such as increased employment opportunities, increased trade and commerce, and/or negatively affected as a result of increased traffic and safety risks associated with the anticipated increase in heavy vehicle movements associated with the project. As is typical for many African rural areas, these settlements are dispersed and scattered along walking routes or road networks. For example, the village of Logu stretches for

over 4km along the N3 comprised mostly of small houses next to the road constructed with a combination of mud and poles (wattle and daub materials).

Walikale is the Territory's main economic and administrative centre, with Provincial Government line department presence, as well as some international aid organisations and NGOs. The town's main economic activity is informal local trading, in addition to motorbike taxi services, guesthouses and money generated by supplying and servicing ASM activities in the Territory.

The majority of PAC households are engaged in livelihood strategies that are almost fully subsistence in nature, and are notably either ASM or agriculturally dependent. People in the area are poorly educated, with few of the surveyed adults having completed senior secondary (high) school, and very few of these subsequently attaining a tertiary education or some form of vocational training. People also lack skills that might otherwise be able to set them up in the wider economic market. The study area also lacks public goods and service provision. Government capacity to deliver on these is highly restricted. As a result, the study area inhabitants have a low level of education, only access health services in times of emergency, and are mostly isolated from centres or towns where these limited services are available. Understandably access to land and its cultivation is crucial for household survival. The majority of the households obtained land tenure through their Traditional Authority with over a quarter of these inheriting these tenure rights. A minority of surveyed households indicated that they rent land parcels for agricultural production, paying this rent by means of reciprocal exchange of household labour, indicating the existence of an informal system of labour exchange between these lessor/lessee households.

Agricultural produce, whether from fields or gardens, is largely for household consumption, with a minority of households reported to be selling all their crops. Two thirds of households are engaged in food gardening, mostly on land parcels separate from the homestead. Field sizes range from a quarter acre to almost a full acre, with most households cropping one field only. Generally, no fertilisers are used, as many households rely on burning their fields after a harvest which is believed to restore the fertility of the land. Cassava and vegetables are the primary crops planted and harvested, with cassava flour and its leaves being an important staple in most households' diets. This is followed by cabbage and maize to make fougou. Rice is planted in wet areas along river basins during the rainy season. Many crops are also intercropped, especially beans and some vegetables. Natural resources are similarly harvested for own consumption, and generally not sold.

Food is most often shared between households, especially agricultural harvests, again a key livelihood coping response in times of stress. Over half (56.3%) of household respondents stated that they do not have sufficient food to eat, with the months June to October being the period of highest food insecurity. Animal husbandry and fishing are not large contributors to household food security or their overall livelihood strategy. Few households seem to raise livestock or hunt for commercial purposes.

Very few people are employed in the formal sector, with regular employment being limited to the mining and public sectors. As such, non-regular work and the informal sector play a substantial role in the respondent households' daily economies (trading, farm labour, tradesman/artisans etc.). Agricultural production and the related activity of selling labour provide income to 53.2% of households. Mining as a non-regular form of employment (informal employment), and accounts for around 18.0% of monthly income, followed by piece work (also non-regular work) at 10.2%. Income from monthly regular employment (mostly referring to formal employment with fixed salaries), was

recorded in only 7% of households. It would seem that income from regular employment, non-regular trading and non-regular mining activities are the most significant income sources (together accounting for 52.0% of the average monthly incomes).

The average monthly income per household seems to be FC66,828 (US\$72.10/month). The majority of households' (~52%) indicated that they earn no income or earn less than US\$1.25 per day. However, the study data indicates that households in the study area are relatively better-off than the majority of households in the DRC, largely due to a seemingly highly developed, but informal ASM industry that significantly elevates these artisanal mining households above the national household income average. Notable in terms of household expenditure is the fact that almost 40% of household income is spent on food, with education and health expenses constituting the bulk of the remaining expenditure. Clearly, these mostly informal and irregular incomes are crucial for ensuring household food security needs are met.

The study area PACs survive by pursuing a variety of livelihood strategies, mixing subsistence and cash-based pursuits - of which ASM activity and subsistence agriculture are the most crucial. In addition to agriculture and ASM activity, people rely heavily on their environment for the collection of a wide variety of natural resources, for a range of reasons, such as food, medicines, fuel, house building, etc. These resources are collected mainly, but not only, by women, and form a significant additional component to households' nutrition and general needs basket.

Eight main health issues were identified as relevant to the study area. Vector-related diseases (such as malaria), and also communicable diseases like TB were considered as being a high risk to the health of the communities. Malaria, for example, is considered to be one of the most significant causes of mortality in the study area. This is a serious disease, and the incidence thereof could potentially increase with an influx of people to the project site.

Soil, water and waste-related diseases, such as diarrhoea in particular, are possibly considered to be high risk issues if no mitigation measures are introduced. Diarrhoea, for example, is ranked as the second cause of premature deaths in the DRC, and the third largest disease group after malaria and lung infections in Manoire Village.

An increase in STI/D's (particularly HIV/AIDS cases) is raised as a concern given the potential influx of job-seekers and related socio-economic changes which could be expected with any development. Although reliable statistics on current infection rates in the study area could not be found, qualitative data does show that HIV/AIDS exist in the communities, although the significance of this is not well-known. There are signs of discrimination against those who carry this disease, although discrimination seems to be limited to financially poorer, more traditional villages where sexually promiscuous behaviour is not common practice.

Malnutrition, on the other hand, is a serious issue in the area. The project could potentially affect this through the in-migration of people into the project area placing additional strain on existing agricultural land availability. However, more importantly, food prices might escalate as a result of an influx of people and more employment opportunities. The relative isolation of these PACs is also reflected in the fact that for the great majority of people in the study area, they are a long way from crucial services such as hospitals, police stations, markets and other public goods and services, with many people having to go to the towns of Walikale and Osakari to secure these. This isolation serves to make everything more expensive, aggravating the poverty in which people already find themselves.

The demographic profile of the area is therefore not conducive to escaping poverty, with limited access to the formal employment market in the current economic context. As such, any proposed project activities that could impact on livelihoods strategies and income sources needs to be understood and assessed.

20.4 KEY PROJECT ASPECTS, ISSUES AND RISKS

20.4.1 Mine Dewatering

It is anticipated that pumping of groundwater from the underground workings will be required at a later stage in the operational phase of the project. The water that will be pumped to surface will ideally be utilised as process water for the processing plant. However, if these quantities exceed use requirements it is foreseen that excess water will need to be discharged into the surrounding environment. This will have to occur in a controlled manner, with the pumped water impounded in a suitable dam structure, analysed and then treated (if required) to meet the applicable water discharge standards, and finally discharged into the receiving environment for runoff into the general water catchment and river systems.

20.4.2 Acid Mine Drainage (AMD)

Acid Mine Drainage (AMD) refers to the outflow of acidic water from metal mines or coal mines. Acid rock drainage occurs naturally within some environments as part of the rock weathering process but is exacerbated by large-scale disturbances characteristic of mining and other large construction activities, usually within rocks containing an abundance of sulphide minerals. These rocks then become exposed to weathering (from water and oxygen) when brought to the surface, and sulphur is released. The ongoing leachate test work conducted by the project design team to date has indicated that tin bearing ore is not acid generating. However, the waste rock that will have to be mined to extract the ore has a greater potential to be acidic and generate AMD.

A conceptual groundwater model of the aquifer dynamics and characteristics was derived from observations on site, such as natural groundwater base-flow (including springs) conditions, inspection of exploration cores, conditions experienced by artisanal miners and borehole testing of five boreholes.

A detailed geochemical study has also been performed. A large number of core, pulp and tailings samples were geochemically studied to determine the anticipated water quality trends during the operational phase of the mine, and over the long-term after mine closure.

The main potential sources of impacts on the groundwater system were identified as the mine pit and the tailings storage facility (TSF). These, together with impacts associated with the processing plant, ROM pad and general site activities are assessed later on.

20.4.3 Tailings Storage Facility

As per the findings of the Site Selection Report for the Bisie Tin Project Tailings Storage Facility (Epoch, July 2015), the following are general hazards associated with a TSF:

- Catastrophic failure resulting in a flow slide from the residue disposal facility.
- Release of contaminated surface water/effluent from the top of the residue disposal facility basin as a result of direct spillage.

- Release of contaminated seepage water from the base of the dam into the groundwater and/or manifesting itself as a downstream surface seep.
- Release of contaminated residue (silt) from the residue disposal facility as a result of erosion due to rain runoff, spillage etc.
- Release of contaminated residue (dust) from the residue disposal facility as a result of surface drying and strong winds.
- Positioning of the residue disposal facility resulting in the loss of housing, agriculture, relocation and compensation to varying degrees.
- Positioning of the residue disposal facility resulting in visual intrusion.

The release of possible toxic/irritating gases emitted from the residue disposal facility has been ignored as this is considered to be of insignificant importance. According to the Epoch report (TSF design team), the various consequences associated with the hazards mentioned above that relate to the Bisie mine site and its surrounding area includes:

- Possible loss of life to people in the area surrounding the residue disposal facility sites in the event of a failure.
- Loss of property (houses, dwellings, infrastructure).
- Illness and sickness to people in the vicinity of the residue disposal facility sites.
- Environmental damage which includes damage to cultivated areas, natural flora and fauna and destruction of aquatic systems.
- Community concern giving rise to delays/objections to, or cessation of, the project arising from the relocation of people, houses, loss of cultivated land, compensation costs.
- Visual intrusion.
- Financial impacts.

Clearly the siting of the TSF is critical so that the risks associated with a partial or full failure event of the dam structure can be avoided. The location alternatives presented in this report are likely to hold more risk to the ecological or biophysical environment than being a risk to residents of Manoire village, or the eventual mine camp accommodation and work areas, which will be located uphill of the TSF. Thus, the TSF location has minimised social risks and impacts, at the expense of some ecological impacts.

20.4.4 Sewage and Wash Water

Domestic sewage is characterised by a high concentration of nutrients, organic matter and a variety of pathogens. As such, it must be properly treated prior to discharge to avoid negative impacts to human and environmental health. The presence of hazardous chemical contaminants is unlikely when the

domestic sewage is not combined with industrial effluents, machine wash water or with effluent from the laboratory, which should be prohibited.

The construction workforce of up to 685 individuals (at peak construction) will generate sewage and wash water that will need to be managed. Sewage and other effluent (grey water) from ablution facilities will be disposed of using a packaged sewage plant as was described. However, although the intention is to establish this facility early in the construction phase, until such time as it has been commissioned, alternative arrangements for disposal of sewage will need to be made. The most practical option in this context would be lined Ventilated Improved Pit Latrines that have been constructed to minimise contamination of nearby water resources.

Once the package sewage treatment plant is fully operational and able to consistently produce an effluent that meets the requisite discharge limits, the treated effluent can then be discharged directly to the environment or used as process water. If the treated sanitary effluent water is discharged into the environment, it must meet national discharge standards. There are a number of different package plant options on the market, each with their own advantages and disadvantages. Based on experience from other remote sites, it is recommended that the preferred options should incorporate the following characteristics:

- Proven ability to consistently produce treated effluent that meets the required discharge limits in a remote context with limited supervision is essential;
- No requirement for a fulltime skilled operator;
- Minimal input of chemical agents;
- Minimal monitoring and chemical analysis required for correct operation;
- Minimal and / or infrequent management of sludge;
- Rapid and reliable on-site technical assistance and availability of spare parts.

Occasionally, sludge from the sewage treatment package plant may have to be removed and this material, which should be regarded as hazardous due to the potential pathogen content, must be disposed of in accordance with the EHS Guidelines for Water and Sanitation (IFC, 2007). Within the urban context the sewage sludge could be transferred to a municipal treatment plant for final treatment to a permissible quality for disposal. However, in the current context, this is not practical. As such, the sludge would need to be stabilized by drying in purpose-built beds or composting. The latter requires mixing the sludge with additional sources of carbon such as sawdust, straw or wood chips in the presence of oxygen to enable the indigenous bacteria to digest both the sludge and the added carbon source. The stabilized sludge can then be dried and either disposed at the proposed landfill or alternatively, applied as a soil conditioner during rehabilitation of the mine, provided that levels of toxic constituents is sufficiently low. If soil application is adopted, soil contamination should be avoided and the soil standard prescribed by the African Development Bank (AfDB) should be adhered to.

The total quantity of effluent requiring disposal during the construction phase could be increased further by washing of equipment such as machinery and vehicles - although the exact quantities produced by these activities cannot be determined. Wash water from vehicles frequently contains at

least small quantities of hydrocarbons (oil, grease etc.) and, as such the washing of vehicles and machinery should be conducted only at permitted and well selected designated wash bays where wash water is collected and routed through a grease trap/oil-water separator prior to discharge.

20.4.5 Landfill Leachate

Leachate from landfill facilities, in particular those designed to accommodate hazardous waste, is likely to contain a variety of pollutants including heavy metals and complex organic compounds. If allowed to escape into the environment, the potential negative impacts on human and ecological health could be significant. Landfill leachate will be captured and brought back into the process water system via the TSF return water line. ABM will need to investigate options for on-site treatment of this leachate should it exceed any thresholds described in the ESMP, before being reused as process water. On decommissioning the landfill leachate management system will be monitored continually to determine that all discharges are within the required threshold limits.

20.4.6 Storm water and Other Runoff

It is important to consider the potential environmental impacts associated with storm water and other run-off. This will include run-off from the stockpiles, waste rock dump and mine pit. The primary threat posed by storm water is that as it has the ability to pick up contaminants, including hydrocarbons, heavy metals, pesticides and nutrients as it moves across a project area. If not managed correctly, these contaminants may then be transported, via the storm water, into areas where they could pose a threat to human and environmental health.

The exact quantity of contaminated water requiring careful management and treatment prior to release from the site is likely to be highly variable and largely dependent on seasonal rainfall. Storm water and machine wash water should be kept separate from sewage water. This would need to be addressed in the design of the storm water system for the site which should take into consideration the use of sealed manhole covers. Prior to discharge, storm water must meet the most stringent of national or IFC limits for effluent.

20.4.7 Explosives Storage

A dedicated explosives storage magazine is required. This requires an approximately 700m safety buffer between it and any other areas on the mine site that are inhabited or staffed by mine personnel during the course of the working day. This is necessary as an uncontrolled explosion or catastrophic event at the magazine – although rare - could lead to significant loss of life and damage to mine infrastructure.

20.4.8 Transport and Traffic

The development and upgrading of roads to service the mine, as well as a significant increase in heavy vehicle traffic, will increase risks to local residents' health and safety. Roads in the area are currently used by large numbers of pedestrians (and bicycles). There will be a significant increase in the amount of vehicle movements in proximity to the mining operation. Although local communities are not unfamiliar with vehicles, the risk of traffic accidents, particularly at night, is still very important. Villages situated along existing roads will be especially at risk. A significant increase in vehicular traffic has implication for not only study area residents in terms of road safety, but also along the entire logistics corridor under consideration.

Dust (PM10) generation by vehicle entrainments can also be a significant issue if not mitigated.

20.4.9 Terrestrial Ecology (Fauna and Flora)

Fragmentation of habitats can lead to the loss of viable populations, especially in animals requiring large home ranges. Mining operations may well have an impact of terrestrial flora and faunal habitats, as well as potentially impact on breeding or foraging habitats of numerous species (birds, amphibians, reptiles, juvenile fish nursery areas etc.). Much of the forests and vegetation found close to the project area has been impacted by humans living and mining in the area since the discovery of tin deposits. However, extensive areas of pristine primary forest still surround the project area. The impact on these areas is likely to increase in the near future as more land is cleared for subsistence agriculture, and with the introduction of tin mining on a commercial scale.

While small areas of forest will have to be cleared for some of the mining infrastructure (e.g. the tailings storage facility), the biggest impact to the local forests will come from the construction of the access/haul road leading approximately 32km from the N3 main road to the mine site. Many trees will be lost during the construction of the road. In addition this road will provide easy access to the area which will encourage local residents from further afield to come into the area looking to utilise the natural resources provided by the forests, and to settle and establish villages and agricultural fields. This will put added pressure on the ecosystem and the few remaining faunal populations.

As mentioned the area has seen a dramatic reduction in the numbers and diversity of resident faunal species, and this is not likely to improve with the introduction of the mining project. Although the number of people living in the area has reduced considerably (many of the artisanal miners have now left the area), the new mining project and its associated noise and transport impacts may prevent some wildlife from returning to the area.

20.4.10 Air Quality and Climate Change

Dust generation could potentially impact on community and worker health due to elevated concentrations of dust (PM10), especially along both roads and cleared areas. The impact of elevated levels of dust could result in an impact of moderate significance, especially when mining and roads are located in close proximity to villages. In addition, dust could be generated once the tailings have dried out, since they are susceptible to wind-blown dispersal. A reduction in the amount of dust generated through vehicles and during mining operation can be effectively mitigated by simply reducing the speed of vehicles, or by wetting road surfaces. Covering the dried tailings with topsoil and re-vegetating the area can successfully mitigate against wind-blown tailings mobilisation.

An analysis of the volume of Greenhouse Gas (GHG) emissions likely to be generated by the project has been undertaken as part of the Air Quality Impact Assessment specialist study in order to provide an indication as to how the project may contribute to climate change.

20.4.11 Aquatic Ecology, Hydrology and Geohydrology

Watercourses - Numerous watercourses, small streams and drainage lines will be impacted on by road construction activities, as well as the valley areas in which the TSF alternative sites are located. Depending on the preferred location of the TSF, there might be a need to divert stream flows that may feed into the TSF located at a valley bottom. This diversion is required to ensure that general runoff does not feed into the TSF dam so as to prevent this filling up with rainwater. The pre-existing

hydrological functions of watercourses impacted by mining operations are likely to be permanently and irreversibly affected. Although it is possible that final landform rehabilitation can replicate its basic function successfully, it will be difficult to do so.

Surface water and storm water contamination – as noted above, surface and storm water can become contaminated through contact with pollutants associated with mining activities such as oils and grease from workshops, hydrocarbons from leaking trucks and pumps, and runoff from refuelling areas. Surface water must be protected from coming into contact with any pollutants and any storm water runoff that passes through potentially contaminated areas must be captured and treated appropriately prior to release.

Groundwater quantity - Mine dewatering activities could affect local groundwater flow due to minor groundwater abstraction activities which could lower the water table, and make it more difficult for local communities to access drinking water from groundwater wells, particularly during the dry season. Careful monitoring of groundwater quantity levels will be required.

Groundwater quality - Mining activities may affect local groundwater quality due to contaminated effluent or contamination through contact with wastes. It is likely that the waste rock will generate AMD, and the subsequent contamination of groundwater is considered a potential risk.

20.4.12 Noise And Vibration

The mining operation will cause an increase in ambient noise levels in the surrounding areas. The residents living adjacent to the project area will be most affected by noise, both during the construction and operation phases. These are likely to be impacts of low significance for the Manoire community that can be mitigated by using standard industry practice to reduce noise and vibration levels. Of particular concern is the noise and vibrations generated from daily blasting in the mine shaft. The effect of this on adjacent communities and safety considerations for the workforce need to receive careful attention during the detailed design phase of the project.

20.4.13 Socio-Economic Benefits

Both indirect and direct economic opportunities will be created as a result of the project. Should the services from the surrounding area and villagers be used, the project should increase the amount of cash-flow into the affected villages and smaller settlements within the greater project area, and may further create opportunities for the sale of goods and services to the mine and mine employees. With the upgrading of services and additional road infrastructure, this might potentially improve access and basic service provision for residents in the project area. The following benefits can be realised:

1. Economic opportunities, both indirect and direct will be created (improved access and increase in amount of cash inflow to villages in the immediate vicinity of the mine; upgraded services and the expansion of road infrastructure; potential improvements in access and basic service provision for residents; and direct economic benefits from employment).
2. Employment benefits and an increase in the skills base in the area. However, the general lack of skills in the study area reduces the benefits to local residents of permanent employment.
3. Social development is likely to take the form of a dedicated Social Action Plan (SAP) to be developed by the proponent.

The project will result in direct economic benefits at both provincial and national levels and any income generated from the project will significantly increase the country's tax-base.

20.4.14 Public Health and Safety

General safety issues will be of importance owing to the proximity of the settlements to existing and potential future access routes for mining operations. The mining operation can pose severe safety risks to individuals who enter the site without authorisation and appropriate safety information and PPE, as well as adjacent communities living close to the site. Should the mine block important access routes and satisfactory alternative routes are not identified, community members might be tempted to cross the mine area, exposing themselves to safety risks or even (in the worst cases) harassment from security personnel.

Accidents involving local residents carry a high risk and can become a source of conflict.

Inward migration and increases in the labour force employed in the area may impact negatively on the health standards of people in villages in the mine expansion area. This, however, needs to be understood within the context of a number of issues. Malaria rates are high in the area and it is unlikely that inward migration will increase these levels. An increase in levels of HIV/AIDS and other STD's is also a concern. Current infection rates for the villages in the project area are not known, but inward migration may increase rates of infection.

20.4.15 Population In-Migration

There is a strong possibility that the prospective mining operation will draw migrant labour in search of employment opportunities. The study area residents are largely poor and uneducated, which means that more educated and skilled labour will certainly be needed from areas such as Walikale or Goma. Such an influx can either cause some of these villages (especially Manoire) to expand significantly, or cause a temporary oversupply of labour.

As with most social impacts, in-migration may also have a positive impact in terms of providing locals with small business opportunities due to an increased demand for local produce and other goods, as well as opportunities for cultural exchange. Although influx is considered outside the control of project developers, the IFC guidelines on project-induced in-migration suggest that influx can threaten 'project security' and that it should be managed as a project threat (cf. IFC, 2009). The direct and indirect impacts associated with an influx of labourers and expats are likely to have significant impacts on these villages, as it usually results in many social, cultural, economic and political changes.

20.4.16 General Access Routes and Access To Natural Resources

The mining operation might limit access to particular areas due to the presence of fences and infrastructure, as well as the mine infrastructure. This may affect existing access routes that local communities rely on, and could make access to natural resources and access between villages difficult or more time consuming. Given the number of access paths used by the local villagers and their location throughout the deposit areas, it may not be possible to design the mine to avoid all access routes completely. Where local access routes might be compromised, mitigation measures will involve the identification of appropriate alternative routes to important resources and between villages. Failure to do so could compromise the livelihood strategies of villagers.

The proposed access road will also allow for much easier access to the mine site, as well as the forest sections along the route. Increased access to what was previously a more remote area for larger settlements in the study area will now be possible. It is anticipated that this could lead to an increase in bush meat hunting, deforestation for charcoaling purposes and possibly commercial logging by external parties. Accordingly, while ABM needs to ensure ongoing access to natural resources for Manoire residents, it will also have to develop mechanisms to ensure that reckless overexploitation of the forest resources does not occur.

20.4.17 Changes to Social Systems and Structures

Social systems and structures have evolved in the study area over generations and are not static, but have responded dynamically to the changing social environment. Any development of the scale of the proposed project will result in significant social change; the influence of the project on the various village social systems and structures is likely to be experienced in a number of ways – both positive and negative. The mining activity, increase in vehicular traffic, intensification of economic activity and improved linkages are all likely to alter the prevailing rural nature of the settlements in their totality. Developments of this magnitude are frequently associated with changes to social structures and associated tensions and social pathologies.

These may be related to a variety of factors, including the influx of outsiders in search of employment, increased wealth, or reliance on cash income, the introduction or increase of communicable diseases, increased crime, disturbance of traditional hierarchies, etc.

20.4.18 Community Or Regional Conflict

Stemming from the above it has been raised by Goma based NGO's that it needs to be understood how the project may impact on the ongoing cycles of violence affecting the study area, and Kivu region in general. While it can be contended that ASM activity is more likely to be subject to manipulation or exploitation by third parties and associated taxation or acts of violence by rebel groups than a commercial mining operation, it is intimated that the project will still potentially contribute to the ongoing violence in the region. It is a pertinent, as well as emotional question for residents and observers in the area. The incidents of historic violence at the mine site, both by artisanal miners or rebel militias, have occurred on a few occasions, and are well documented.

In addition, conflict can and often does arise from economic or physical displacement of inhabitants in these commercial mining contexts. However, it is the stated intention of ABM that no one will be physically resettled. However, it may well be that once the remaining tin ore stockpiled by the artisanal miners still on site is transported out of Bisie and sold, there will be a large reduction in the numbers of residents in Manoire as they migrate to alternative ASM sites. Preliminary discussion with ASM cooperative representatives in Manoire have indicated that they would probably eventually leave for other sites designated for ASM. This in itself is a large disruption to miners and/or their families living there, and the voluntary relocation to other areas in itself often results in conflict with host communities receiving these persons that are essentially economic migrants.

It is anticipated that engagement on these issues with various interest groups and observers could identify what the potential, if any, driver/s of violence the project may introduce or perpetuate. It must be noted here that a dedicated study on this issue may well be necessary, but in itself is a major research undertaking that is beyond the remit of this ESHIA process. It is therefore recommended that

a Project-level Conflict and Risk Impact Assessment (P-CRIA) study is undertaken for the project in accordance with International Alert's methodology developed for these purposes (International Alert, 2005). This is necessary in order to address deficiencies in general ESIA processes that are often criticised as being incapable of "analysing and assessing the full range of issues that might cause, trigger or exacerbate tensions or violent conflict" (IA, 2005, S 3, p 4). Many of the issues are readily apparent to ABM, namely:

- Tensions between ASM cooperatives and the company, as well as associated unhappiness with the government regulators of ASM activity, as a result of the ban on artisanal activities at Bisie;
- Existing perceptions or fears amongst some sectors of local society and prominent family clans that access to project benefits will be highly deferential, and not predominantly spread around those communities most directly affected by the project, and therefore not in their best interests;
- A strongly voiced belief amongst stakeholders that the delay in the finalisation of the Memorandum of Understanding that will be the foundation (or point of departure) for the establishment of the social development foundation is being delayed unnecessarily;
- A strong (and unrealistic) perception amongst the majority of PACs that the provision of basic services (schools, hospital, sanitation etc.) should be ABM's responsibility and not that of local government. This can be problematic in that it raises community expectations from the project that will never realistically be met.

These, and other issues that are likely to be identified, must be subject to analysis and the development of appropriate mitigation and intervention measures by a suitably qualified service provider who will conduct the P-CRIA process. All effort will be made however to capture the various views and opinions on this critical aspect of daily life in the study area and region in general. In doing so it is hoped that at least these concerns and possible mitigation measures stemming from the ESHIA consultation process may serve to provide the platform for all actors to cooperate in resolving the causes and ongoing repetitions of these highly unfortunate events.

20.5 EFFECTS OF THE PROJECT ON GLOBAL CLIMATE CHANGE

Based on various studies on the likely climate change scenarios for DRC and the associated biophysical and socio-economic impacts, it is likely that the area will become hotter and that rainfall will become more variable. Although the direct contribution of the proposed mining operation to global climate change is expected to be limited, it will have the potential to exacerbate impacts of climate change. The impacts on local communities that rely on natural resources, particularly in times of drought, may be particularly vulnerable. ABM will implement various mitigation measures aimed at reducing this vulnerability, including provision of assistance to improve agricultural yields and the reliability of water supply.

20.6 SUMMARY OF IMPACT FINDINGS AND RECOMMENDATIONS

In summarising the findings and recommendations of the preceding chapters the following summary conclusions can be drawn.

20.6.1 Terrestrial Ecology Impacts

The proposed mining operation will contribute to local deforestation which may cause the loss of some species of conservation concern, sensitive habitats, such as the riparian habitats along the valley bottoms, and the displacement of some faunal species from the immediate area of the mining footprint. However if the mine development incorporates the mitigation measures described in this ESHIA, and considering that the mine footprint (i.e. the scale of the mining development in relation to the extent of the surrounding forests) is small, and that this area has already seen many years of mining activity, the overall ecological impact could be defined as moderate to low. Nevertheless, it is still important that the mining operation take the necessary management steps to help reduce the loss of (1) large areas of intact woodland, (2) loss of sensitive habitats such as riparian areas, (3) habitat fragmentation, and (4) unsustainable utilisation of faunal populations for food. If ABM can control the number of people living in and around the mine site, or set aside restricted access areas and poaching pressures are reduced, then there is the possibility that some large-to-medium faunal groups may return to the area.

Probably the most significant ecological impact will be the construction of the access road from the main N3 road. This will involve clearing an approximately 20m wide area of nearly 32km long of Primary and Secondary Forest. There are many tall and mature trees along the proposed path of the access road, and large tracts of sensitive habitat will be cut down and cleared to make space for the access road. This will provide easy access into the forest interior for many people from the Walikale area, and without any mitigation will probably lead to a rapid and un-sustainable exploitation of the natural resources provided by the forests. Commercial loggers and charcoaling groups will probably take advantage of the road to move quickly and easily in and out of the area, and it will probably be utilised by non-mining vehicles (e.g. public transport or motorbikes) to access Manoire village.

There is the potential for the number of people in Manoire village to expand rather than be reduced by ex-miners leaving (as suggested at the time of the survey) and this will inevitably put additional pressures on the forest ecosystems all along the access road as well as in the vicinity of the mine. Even after the mine is closed it is likely that the local communities will continue to use the access road which will provide easy access to Manoire village. The road will provide ongoing access to the natural resources provided by the forests along the 32km stretch of road on closure of the mine, which may lead to over-exploitation and result in permanent damage to the forest which may never recover. This secondary impact will be difficult to mitigate.

The removal of the forest habitats will have a negative impact on the few remaining mammal species, but once mine construction is complete, and if ABM develops and implements a Conservation Management Plan and educates its staff on the value of the fauna and flora, then an environment may be created into which some faunal species may return. For example, since the cessation of the artisanal mining and a reduction in human activity in the area, there have been sightings of monkeys in the Bisie River valley for the first time in many years. It is likely that other endemic, near-endemic and IUCN-listed species are to be found in the area, particularly small mammals (mice and shrews).

20.6.2 Aquatic Ecology Impacts

Project induced impacts on aquatic ecology are deemed to be of generally low significance as it relates to proposed project activities and infrastructure aspects. The risk of future acid mine drainage (AMD) arising from the waste rock dump or TSF appears to be relatively low, but remains the highest risk impact or concern for surrounding surface water quality at this time. However, should the recommended mitigation strategies listed in this report as well as the ESHIA be implemented correctly, it is anticipated that these potential risks and aquatic impacts will be reduced to low overall significance.

20.6.3 Ground And Surface Water Impacts

All surface and groundwater sources are used by the local population as sources of supply for domestic use, including drinking. The main rivers in the area, the Bisie and the Oso Rivers, are presently in an unmodified condition. Existing human impacts relate mainly to small-scale agriculture, clothes washing, clearing of the riparian areas in some places, and the construction of informal river crossings. Artisanal mining has resulted in deposition of sediment in the Bisie River. Surface water samples were taken from 15 points around the site, and analysis indicates that surface water is generally suitable for human consumption when compared with WHO guidelines (and South African standards where there is no WHO guideline level), except for the presence of E coli (source and strain unknown), and elevated chlorate / chlorite levels in the Oso River water upstream of the Oso / Bisie confluence. Slightly elevated levels of iron (Fe) were detected in one eastern and one western tributary of the Bisie, as well as elevated levels of manganese (Mn) in samples taken on the ridge, but both were within limits for the limited period (less than seven years) consumption.

Geochemical studies indicated that the hanging and foot wall rocks have variable sulphur contents, and that in most samples the sulphur content is sufficiently high to generate acidic drainage if exposed to oxygen and water. The mine water quality is expected to be of low pH (<4), possibly as low as 2; depending on the aspects which influence acid rock drainage. The neutralisation potential of the rock is very low. It is probable that the acid leachate will carry high concentrations of metals, including copper (Cu), cadmium (Cd), iron (Fe), nickel (Ni), lead (Pb), arsenic (As) and zinc (Zn). Cadmium is a very persistent contaminant (present in the rock because of its natural association with zinc mineralisation), and will leach from the rock even under pH neutral conditions. Both the acid generating and neutralising potentials were insignificant and any liberation of acid or transition metals as a result of sulphide oxidation would occur at a rate that would ensure the concentrations in the leachate remained negligible. Based on the data provided, all three samples can be classified as low risk in terms of acid generating potential and the potential to leach harmful elements into solution. However, ongoing monitoring and analysis programmes will be implemented for the life of mine (including mine closure and decommissioning) where the AMD potential will be assessed and managed by ABM.

There is potential for the surface and groundwater resources in the vicinity of the mine to be contaminated from a range of mining related sources, including hazardous materials such as chemicals and hydrocarbons, domestic sewage and landfill leachate, acid mine drainage and acid rock drainage. The latter are considered to be the most significant sources of potential contamination, and measures have been proposed to mitigate the impacts.

A total of 19 impacts were identified for the construction, operation and closure / post closure phases of the project, including one cumulative impact. Before mitigation the significance of 5 impacts were rated High negative, 10 were Moderate negative, and 3 were Low negative. After mitigation 1 impact was rated Moderate negative and the remaining 17 Low negative. One impact was rated Low beneficial both before and after mitigation.

20.6.4 Air Quality Impacts

Atmospheric dispersion modelling indicates that the project's operations are not likely to result in exceedances of the selected criteria for NO₂, SO₂, and VOCs at surrounding sensitive receptors. There are likely to be exceedances of the daily PM₁₀ and PM_{2.5} levels outside the project boundary as a result of dust generation. If hooding with fabric filters were fitted to the crushers; and, water sprays were installed at the crushed ore transfer points ambient particulate concentrations as a result of the project are likely to comply with recommended criteria. Simulated diesel particulate matter (DPM) concentrations as a result of vehicle and generator exhaust are likely to result in moderate to high increased life-time cancer risk at the plant boundary. Fitting diesel particulate filters (DPF) to the exhausts is likely to reduce the increased life-time cancer risk at the plant boundary to between moderate and low.

Project Greenhouse Gas (GHG) emissions are estimated to be between 23 524 to 25 124 tCO₂ per year. The largest source of GHG emissions at the project will be the diesel fuel usage (22 021 tCO₂ per year), due to the large volumes of fuel used for mining and for electricity generation on-site. The IFC Sustainability Framework (Version 2) requires reporting of GHG emissions above the threshold of 25 000 tCO₂ p/a. Reporting is therefore only likely if above-ground biomass is greater than 300 tonnes of dry matter per hectare and if more than 10 ha will be cleared – as noted above it is estimated that the access road and surface infrastructure components will require the clearance of up to 70ha of forest of varying sensitivity. This exceeds the IFC's threshold and would therefore be regarded as a significant contribution to CO₂ emissions. In addition to this, diesel required for refuelling of the plant both during construction and operation as well as the clearance of approximately 100 ha of vegetation (access road, TSF and other surface infrastructure) will also contribute to the production of carbon emissions. It is recommended that a carbon footprint be established for the facility within the first year of operation. This must take into consideration the loss of vegetation. Thereafter it will be necessary to develop a greenhouse gas management plan for the operation with the specific intention of reducing GHG emissions as far as practicable.

The environmental significance of the project operations is moderate without mitigation applied, and low with the recommended mitigation measures applied.

20.6.5 Waste Impacts

A review of relevant legislation and policy documents suggested that waste management in the DRC is still in its infancy, with limited legislative guidance and only a single engineered landfill site in the country. This may change over time as mining and other industry enhances the economic profile of the area but is unlikely to occur in the near future. Consequently, the developer should employ measures to effectively manage the waste generated from the project in order not to contribute further to poor waste management practices locally.

Based on the available project description and supplementary information sourced from a variety of sources, it was possible to make an assessment of the likely impacts associated with the management of waste streams from the proposed Bisie tin mining project. This will, however, need to be reviewed once further detailed information on, in particular, management of process waste streams becomes available.

It is recommended that all waste streams should be managed according to the waste management hierarchy and, as a minimum, according to DRC legislation. Wherever practical, production of wastes should be prevented or minimised at source. Where prevention or further minimization is not possible, wastes should be re-used, recycled and then disposed of responsibly so as to minimise impacts to the environment. Further guidance on the management of waste streams is provided in the IFC General EHS Guidelines (2007) and the IFC EHS Guidelines for Mining (2007). In the event that there are no national standards available, the proponent must comply with internationally recognised standards developed by international organisations such as the IFC. In the case where there are several standards available for use, the proponent must provide justification for the choice of use, other than the use of the most stringent.

Considering the context of this project, it is also concluded that inclusion of on-site landfill facilities for final disposal of non-hazardous and hazardous wastes is appropriate from an environmental risk perspective. However, the Closure Plan for the mine will need to include details of closure of these facilities as well as post-closure monitoring requirements.

20.6.6 Traffic and Transport Impacts

The supply of equipment and materials for the construction phase will require an approximate total of 168 deliveries by large multi-axle trucks (this figure excludes material coming from local sources: aggregate, sand, general civil and building material, fill material for TSF embankment). The logistics corridor is via the Port Of Mombasa, through Tanzania and Uganda, before entering the DRC and being routed to site via the city of Kisangani. Currently there is no direct access to site from Goma or Bukavu owing to poor road conditions and collapsed bridges. The construction period is scheduled to take 18 months, commencing in June 2016 with production of tin anticipated in the first half of 2018. The majority of material delivery is likely to be concentrated in the first 6 months of construction.

The remoteness of the site and the poor road conditions (especially in the DRC) poses a logistical challenge to the project. GIS data downloaded from the African Development Bank's GIS database indicates that 1,073 km of road in the DRC is described as being in "bad" or "very bad" condition. 252 km's of road is described as being in average or good condition. In Uganda, only 11 km's of the proposed route is described as being in "bad" condition. The remainder of the roads in Uganda (443 km) are described as being in "good", "fair", or "unknown" condition. In Kenya, only 201.5 km out of a total of 1,693.7 km is described as being in "poor condition". The remainder if the roads in Kenya are described as being in "fair" or "good" condition. In Kenya, all roads are paved. In Uganda, 52% (238 km) of the haul route is paved, and 48% (216 km) is unpaved. In the DRC, 31% (410 km) of the haul route is paved, and 69% (915 km) is unpaved. The condition of the unpaved routes may be worse than described in this report during the rainy season. None of the impacts identified are very serious, and with common-sense mitigation measures implemented can be mitigated to acceptable risk levels. This will ensure that communities and pedestrians are protected, other road users are not negatively affected, and the mine's operations run smoothly.

20.6.7 Socio-Economic Impacts

The proposed project has the potential to significantly enhance the standard of living of those directly affected (Manoire village) as well as the population in the Walikale Territory as a whole in terms of employment, agricultural capacity building, creation of small businesses and social development. These impacts are particularly important in an area where poverty is endemic and employment opportunities are absent. Expectations of job opportunities and development projects are high amongst local residents. It is very important therefore to instil realistic expectations with regards to benefits from the project, and to develop a strategy of equitable distribution of job opportunities and benefits amongst the affected parties.

The skills base in the area is poor. In order to optimise local employment opportunities, skills training will be necessary. Particular attention will need to be given to women and youth, as well as vulnerable households. The seemingly insecure economic situation of the Manoire population, largely as a result of legal cessation of ASM activity, will require appropriate consideration and prioritisation of these residents for employment (short and long term), as well as small business development opportunities that the project is likely to stimulate. It is foreseen that this dedicated Social Action Plan, and the already established Lowa Foundation (ABM foundation governing its activities, will focus primarily on these directly affected communities and vulnerable household's whose incomes and livelihood strategies have been impacted on since the cessation of artisanal mining on site.

The potential and substantial benefits arising from the project may also lead to conflicts in households and in their villages, as well as between villages. These impacts are difficult to manage and largely beyond the control of ABM, but it does emphasise the importance and need for long term capacity-building and local economic stimulation to ensure that the distribution of benefits are deemed to be equitable by PACs. As noted previously it is probably essential that a more detailed conflict analysis and management exercise is conducted by an external service provider familiar with the project context and conflict dynamics in the Kivu's, and in Walikale Territory itself.

Although ABM is committed to zero resettlement, agricultural land, which is the most important asset of local residents, is likely to be affected by project infrastructure. This potential loss of agricultural land needs to be managed appropriately and fair compensation for these losses paid. A detailed and transparent Compensation Plan, as well as a Stakeholder Engagement Plan will be critical to mitigate the loss of agricultural land and livelihoods.

An influx of migrants/job seekers into the study area potentially leading to prostitution and increased HIV/AIDS infections, an increase in crime or communal conflict, inflation and land speculation are impacts that are particularly difficult to manage. Because ABM does not have direct control over these aspects they will need to work in collaboration with other stakeholders to minimise these potentially harmful impacts, realising that full or entire mitigation is probably not possible, but that robust and transparent conflict analyses and resolution approaches - along with proactive management planning around these potential flashpoints - is essential to ensure the minimisation of these triggers of conflict. Although mitigation measures are available to deal with these potential conflicts, this issue remains of moderate to high overall significance.

20.6.8 Health Impacts

Of the eight main issues identified, vector-related diseases (such as malaria), but also communicable diseases like tuberculosis (TB), were considered as being a high risk to the health of the communities as a result of the project should no mitigation measures be implemented. Malaria, for example, is considered to be one of the most significant causes of mortality in the study area. This is a serious disease which could potentially increase with more breeding habitats for mosquitoes, which might be associated with an influx of people or the deterioration of current living conditions. The project could potentially affect the rate of malaria by creating new water bodies for the vectors to breed in, or an influx of people can also potentially change the environment and land-use practices in the area.

Particular soil, water and waste-related diseases, such as diarrhoea in particular, were considered as possible high impact issues if no mitigation measures are introduced. Diarrhoea, for example, is ranked as the second cause of premature deaths in the DRC, and the third largest disease group after malaria and lung infections in Manoire village. The project could potentially affect the occurrence of diseases such as diarrhoea as a result of poor water and waste-related standards and practices which could affect the underground water table and local rivers. However, these potential impacts will be of low significance provided they are appropriately managed through adherence to best practice principles.

An increase in incidences of Sexually Transmitted Infections (STI's) and HIV/AIDS are raised as a possible concern as a result of the anticipated influx of job-seekers to the mine site (Manoire village). This issue was extensively discussed in the report, although reliable statistics on local HIV infection rates could not be found. However, the qualitative data does show that HIV/AIDS exist in the communities, although the significance of this is not well-known. There are signs of possible severe discrimination against those who carry this disease, although such discrimination seems to be limited to financially poorer, more traditional villages where sexually promiscuous behaviour is not commonly practiced.

Malnutrition, on the other hand, is a serious issue in the area. The project could potentially affect this through an influx of people into the study area who could put additional strain on existing land usage and yields. However, more importantly, food prices might escalate as a result of an influx of people and more employment opportunities. With appropriate mitigation measures and project benefits, malnutrition, as with many other issues, can actually be reversed and become a project benefit. For example, as demonstrated in the specialist report, with appropriate measures, the project could improve food security significantly.

Lastly, it is believed that the project could have an effect on social determinants of life, especially issues such as substance abuse and domestic violence. Both these issues are significant in the study area; however the impact thereof can be minimised or even reversed with appropriate measures.

20.6.9 Ongoing Mitigation and Management

Environmental and social mitigation and management measures have been developed for these and other less significant impacts identified in the ESHIA process. These measures form part of the Environmental & Social Management Programme (ESMP) for the project. The ESMP describes the management structure responsible for environmental, health and safety aspects and the personnel required to ensure its success. The ESMP has been developed with reference to the legislation of the DRC, World Bank (WB) guidelines and the International Finance Corp. (IFC) Performance Standard

requirements and guidelines. The ESMPr similarly details the ongoing monitoring, auditing and reporting, as well as the decommissioning and closure criteria to be met by ABM throughout the projects lifespan.

21 CAPITAL AND OPERATING COSTS

21.1 CAPITAL EXPENDITURE

As part of the Updated Feasibility Study, Alphamin appointed DRA to develop the Control Budget Estimate (CBE) for the project capital cost.

The CBE has been compiled by DRA and Alphamin. The areas of key responsibilities are as follows:

DRA – Responsible for the mine design and schedule, processing plant design, site infrastructure design, project indirect costs and design development estimate.

Alphamin – Responsible for owners cost incurred prior to production of tin in concentrate.

21.1.1 Basis of Capital Estimate

21.1.1.1 Estimate Accuracy

For the scope of work covered and the estimating methodology applied, the CBE estimate is presented herein, has an accuracy provision of -10 to +10 %.

An allowance for design development and design changes has been incorporated in the CBE to account for omitted costs or unforeseen design changes.

21.1.1.2 Estimate Base Date

The estimate base date for the CBE is Q1 2017.

21.1.1.3 Taxes

All applicable duties and taxes have been included in the capital cost estimate with the exception of Value Added Tax (which has however been included in the Project peak funding requirement).

Alphamin has applied for exoneration of import duties as allowed under the Mining Code. This exoneration on import duties lowers the import tax from 20% to 3%, and is applicable to imported mining related equipment, reagents and consumables. An allowance of 5% of the mechanical equipment and mobile machinery value has been made in regards to import duties.

21.1.1.4 Scope of Work

The scope of the estimate covers:

- Project direct costs:
 - Mining portal surface infrastructure
 - Electrical infrastructure for mining operation
 - Underground and surface mobile equipment for mining operation
 - Water and air services for mining operation
 - Underground development associated with capital footprint

Bisie Tin Project**NI43-101**

- Crushing and screening equipment
- Jigging and coarse milling circuit
- Gravity separation
- Sulphide flotation
- Tailings thickening and pumping
- Process water and air systems
- Reagent preparation and distribution
- Concentrate filtration and bagging
- Tailings storage facility and return water dam
- Waste rock dump
- Access and haul roads
- Fixed wing landing strip
- Power generating plant
- Water and sewage treatment plants
- Communications, access and security
- Explosives storage
- Staff accommodations
- Transport and logistics of construction equipment
- Project indirect costs
 - Owner's team costs
 - First fill and project consumables
 - Commissioning and strategic spares
 - Temporary construction services
 - Project services
 - Design development allowance

21.1.1.4.1 Mining

The CBE estimate for the surface and underground mining is based on the capital footprint as outlined below.

Figure 21.1 Mining Capital Footprint

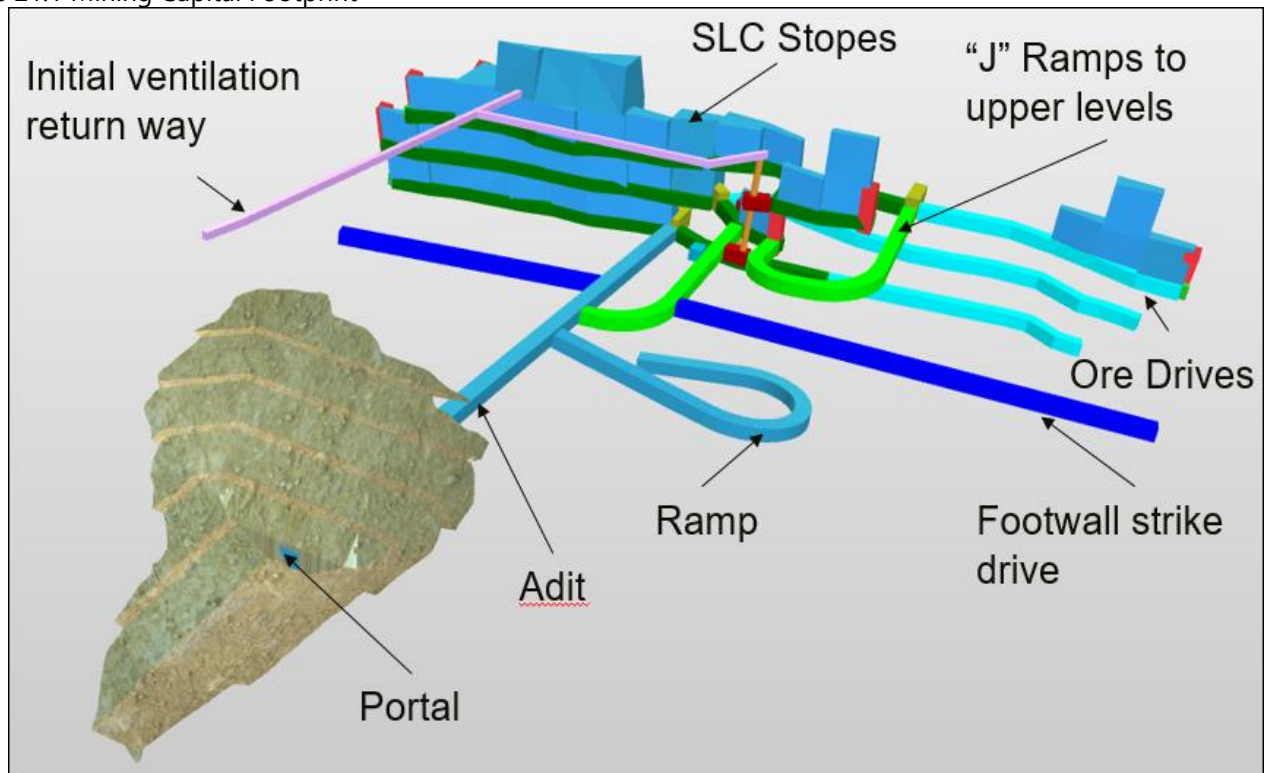

Infrastructure costs are based on the electrical, air and water services required for the capital footprint. The ore drives depicted in the capital footprint will generate approximately 65,000t of ROM material. This material will be used for plant commissioning and ramp-up to nameplate capacity.

21.1.1.4.2 Processing

The process plant capital cost estimate is based on the capital footprint as outlined below.

Figure 21.2 Process plant design

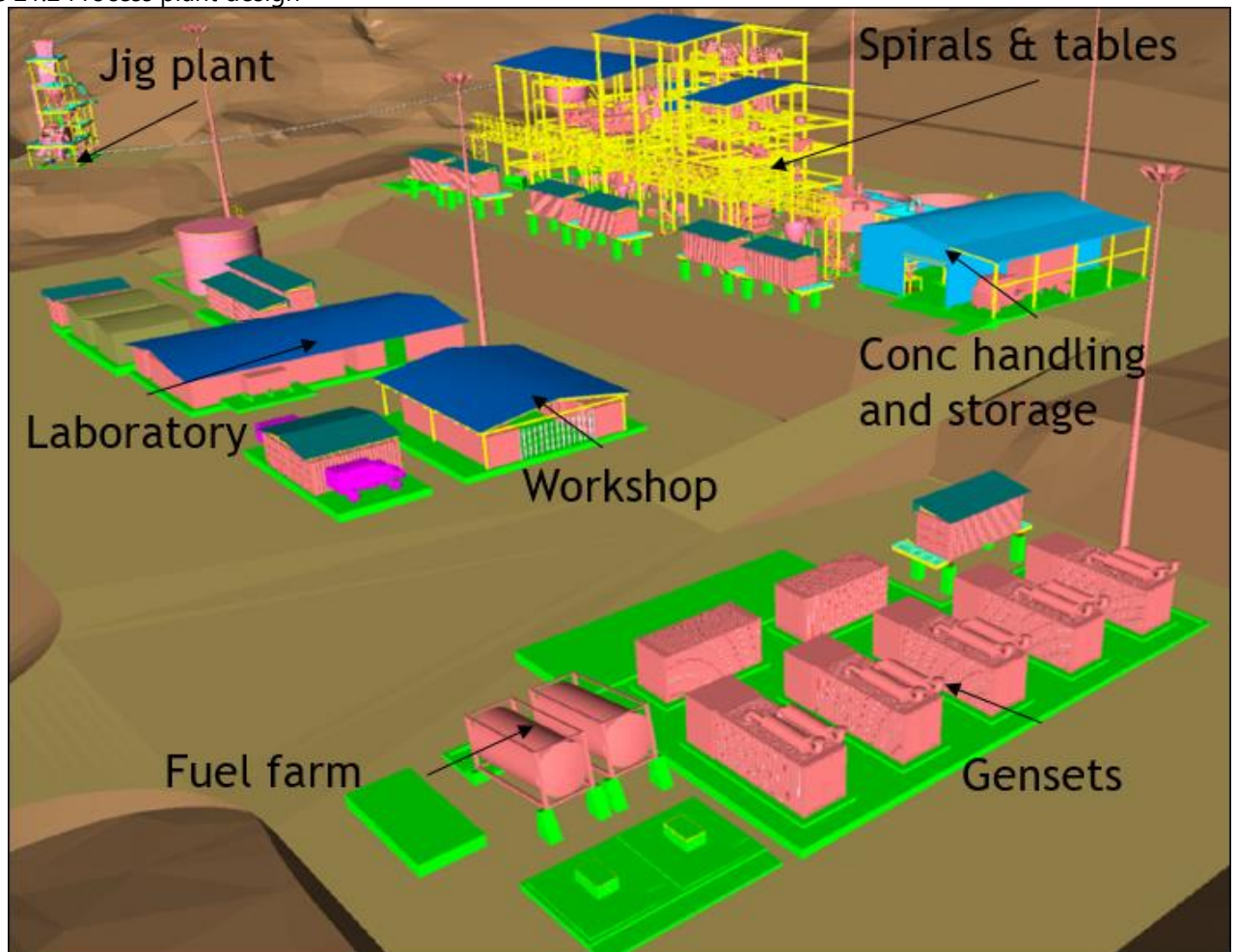

21.1.1.5 Exclusions

The following costs are not included in the capital cost estimate:

- Value added tax
- Schedule acceleration costs
- Schedule delays and associated costs, such as those caused by:
 - Unexpected site conditions
 - Unidentified ground conditions
 - Labour disputes
 - Force majeure
- Financing costs
- Foreign exchange fluctuations
- Cost associated with third party delays
- Development fees and approval costs of Statutory Authorities

- Change in law and regulations
- Escalation

21.1.2 Control Budget Estimate

The purpose of the CBE is to establish the project budget to sufficient accuracy to allow investment decisions. The estimate will provide the pertinent cost data to establish the control budget for moving forward into project execution (procurement and field construction).

The capital cost estimate was compiled based on the following parameters:

- Foreign currency elements of quoted prices were converted to United States dollars.
- Conducting a quantitative risk analysis to establish the required level of contingency.
- Firm bid prices for all mobile mining equipment were obtained
- Committed mining rates were obtained through a competitive mining tender process;
- Firm proposals were received for equipment packages.
- Material take-offs were developed from detailed engineering plans. Pricing for the associated concrete, structural steelwork, mechanical bins and chutes, process piping and valves, electrical, and instrumentation items was based on actual quotes received and checked against recent experience with similar projects within the DRC.
- Labour rates were based on similar mines within the Democratic Republic of Congo. Expatriate rates include all required in-country taxes.
- Implementation efficiency was calculated based on historical project experience and inclement weather factors were included within the execution program.
- Logistics costs were calculated from rates obtained through a competitive tender process. These include sea and road freight as well as rough terrain haulage costs to Bisie.

The table below details the project capital costs for the project:

Table 21.1 Project Capital Costs (cost in US\$ millions)

DESCRIPTION	Vendor packages	Earthworks	Mining	Civils	Buildings	Structural		Platework		Mechanicals		E&I		Piping and valves		Transport	Import duty	Pre-production	Project services,	Spares	Total
						Supply	Erect	Supply	Erect	Supply	Erect	Supply	Erect	Supply	Erect						
Surface mining	Nil	1.70	Nil	1.26	0.01	0.06	0.03	Nil	Nil	0.44	0.08	0.41	0.09	Nil	Nil	0.13	0.04	Nil	Nil	0.01	4.25
Underground mining	Nil	Nil	18.11	0.08	Nil	Nil	Nil	Nil	Nil	4.77	0.09	0.59	0.54	0.01	Nil	0.83	0.47	Nil	Nil	Nil	25.48
Plant	0.61	1.02	Nil	2.77	Nil	4.71	2.23	1.57	0.51	6.04	1.41	2.83	2.00	0.62	2.31	3.09	0.71	Nil	Nil	0.44	32.88
Infrastructure	1.68	17.46	Nil	2.41	0.49	0.38	0.18	Nil	Nil	2.29	0.29	1.94	0.21	Nil	Nil	0.79	0.31	Nil	Nil	0.11	28.54
Indirect costs	Nil	Nil	Nil	Nil	Nil	Nil	Nil	Nil	Nil	Nil	0.86	0.02	0.20	Nil	Nil	1.37	0.05	4.00	12.95	0.34	19.80
Design development	0.23	1.64	0.91	0.53	0.06	0.39	0.23	0.12	0.05	0.68	0.22	0.54	0.30	0.03	0.20	0.47	0.20	0.20	0.97	0.09	8.05
Total	2.51	21.81	19.01	7.05	0.55	5.54	2.68	1.69	0.56	14.21	2.95	6.34	3.35	0.66	2.52	6.68	1.77	4.20	13.92	0.99	118.98
% of total project costs	2.11%	18.33%	15.98%	5.92%	0.46%	4.65%	2.25%	1.42%	0.47%	11.94%	2.48%	5.33%	2.81%	0.56%	2.12%	5.61%	1.49%	3.53%	11.70%	0.83%	100.00%

ABM will continue to incur owners operating costs during the construction period up to and including the ramp-up to full production

Table 21.2 Control Budget Estimate

AREA	CAPITAL COSTS (US\$ MILLION)
Mining	29.7
Process plant	32.9
Infrastructure	28.5
Project indirect costs	19.8
Contingency	8.0
Owners costs	32.5
Total capital costs	151.4

21.1.3 Escalation

No provision for escalation has been included in the cash flow model.

21.1.4 Foreign Exchange

A forex schedule has been developed for the project based on the following exchange rates

- USD1 : ZAR14.29
- USD1 : AUD1.30
- USD1 : EUR0.90
- USD1 : CNY6.68
- USD1 : GBP0.82
- USD1 : CAD1.34
- USD1 : JPY104.17

Table 21.3 Foreign currency schedule

	Foreign Currency						
	ZAR	CNY	JPY	EUR	USD	AUD	GBP
Foreign value	340 799 704	246 369	1 973 045	2 142 004	80 276 170	965 102	415 121
USD value	25 014 698	36 909	18 941	2 365 201	80 276 170	739 007	507 402
%	23%	0%	0%	2%	74%	1%	0%

21.2 OPERATING COST ESTIMATE

21.2.1 Basis of Estimate

21.2.1.1 Estimate Accuracy

For the scope of work covered and the estimating methodology applied, the operating cost estimate as presented herein, has an accuracy provision of -10 to +10 %.

21.2.1.2 Estimate Base Date

The estimate base date for the Definitive Feasibility study is Q1 2017.

21.2.1.3 Exchange Rates

The project OPEX estimate is reported in United States Dollars (USD), with all other currencies converted to USD at the project rate of exchange. The project rate of exchange applied is as follows

- USD1 : ZAR14.29
- USD1 : AUD1.30
- USD1 : EUR0.90

21.2.2 Mining

The mining operating costs comprises:

- All waste development costs below the first 3 production levels.
- The cost of all service raises (Exhaust ventilation raises) below the 3rd production level including equipping of these raises.
- The cost of stoping, ore drive development and slot raising.
- All costs associated with the maintenance of infrastructure during steady state
- All bulk supply costs associated with mining at steady state
- All costs associated with the owners' labour team at steady state.

The mining costs are presented below.

Table 21.4 Mine operating costs

Area	Total (US\$)	Cost / tonne (US\$)
Development costs	181 416 839	38.82
Stoping costs	128 746 737	27.55
Contractor time related costs	23 794 890	5.09
Total	333 958 466	71.47

21.2.2.1 Stoping Cost

The stoping costs are broken down as follows.

Table 21.5 Stopping costs

Activity	Cost / tonne (US\$)
Drilling	4.8
Blasting	5.7
Load and haul	4.5
Maintenance	7.4
Overhead allocation	1.9
Contingency	3.3
Total	27.6

21.2.2.2 Development Costs

The development costs are broken down as follows.

Table 21.6 Unit development costs for a 4.0mW x 4.5mH end

Activity	Cost / m (US\$)
Drilling	570
Blasting	282
Load and haul	412
Ground support	755
Maintenance	1 654
Overhead allocation	933
Contingency	1 151
Total	5 757

21.2.3 Process Plant

21.2.3.1 Reagent consumption

The plant is designed for a throughput of 360 – 390 000 t/a. From the metallurgical test work campaign, reagent consumption rates have been forecast as follows.

Table 21.7 Reagent consumption costs

	Consumption rate (g/t feed)	Solid feed rate (t/hr)	Annual consumption (t reagent)	Unit costs (\$/t ent)	Cost (\$/annum)
Flocculant	20	16.3	2.28	1 592	3 633
Frother	41	2.4	0.60	3 623	2 496
Collector	80	2.4	1.34	3 174	4 266

21.2.3.2 Grinding Media

The grinding media costs have been forecast as follows.

Table 21.8 Grinding media costs

	Consumption rate (g/t feed)	Solid feed rate (t/hr)	Annual consumption (t)	Unit costs (\$/t ent)	Cost (\$/annum)
Primary mill balls	100	4.1	2.87	2 995	8 596
HG regrind mill balls	120	1.2	1.01	2 995	3 019
LG regrind mill balls	120	4.7	3.95	2 995	11 824

21.2.3.3 Other plant consumables

A variety of other plant consumables have been estimated as follows.

Table 21.9 Other plant consumables

	Replacement frequency/annum	Cost per annum (\$)
Jig media	1	4 101
Jaw crusher liners	5	23 405
Cone crusher liners	10	90 456
Screen panels	2	14 372
Conveyor belts	0.2	9 936
Lubes and oils	0.2	14 321
General liners	0.2	145 790

21.2.3.4 Laboratory and Assay

The assay cost has been treated as a fixed cost at \$336,000 per annum.

21.2.3.5 Maintenance Cost

The maintenance costs have been estimated from other similar operating plants as follows.

Table 21.10 Maintenance cost forecast

	Cost per annum (\$)
Electrical, control and instrumentation	65 562
Blowers, compressors and vacuum pumps	14 976
Crushers and mills	98 442
Pumps, piping and valves	120 459
Gravity separation	39 981
Flotation	25 679
Other	39 822

21.2.3.6 Tailings Storage Facility

The tailings dam operating costs comprise:

- Trucking the jig tailings from the process plant to TSF
 - Clearing, grubbing and rip-and-re-compacting the area under the waste rock;
 - Clearing and grubbing under the Jig Tailings;
 - Placing and spreading the Jig Tailings and waste rock;
 - Placing a 500 mm clay capping layer over the Jigs Tailings; and
- Constructing the TSF impoundment wall with Jig Tailings, which includes:
 - Placing and spreading the Jig Tailings,
 - Compaction with a roller, and
 - The construction vehicles required (roller, dozer, etc.);

The operator fixed costs for TSF operation are \$1.37/t milled and the variable costs are \$3.57 per ton milled.

21.2.4 Power

The power generation costs were calculated as follows

Table 21.11 Power generation costs.

Item	Units	Result
Average running load	kW	3 900
Power required per year	kWh	28,641,600
Fuel consumption rate	g/kWh	235
Volume fuel required	liters	8,109,369
Delivered price	\$/liter	1.51
Fuel consumption costs	\$/yr	12,226,433
Lube oil costs	\$/yr	126,985
Spare parts	\$/yr	41,391
Total operating costs	\$/yr	12,394,809
Energy production costs	\$/kwhr	0.433

21.2.5 General & Administrative

21.2.5.1 Occupational Health

Alphamin Bisie Mining SA (ABM) has 60 employees on its books. The historical healthcare costs for these 60 employees and their dependents is \$40 per employee per month.

Moving into the operational phase, ABM expects to employ approximately 410 persons (excluding the mining contractor and 3rd party security contractor employees) for which it will be responsible to provide healthcare.

On this basis, annual medical costs of \$196,800 have been allowed.

21.2.5.2 Security

ABM will increase the planned complement of PNC officers from 30 to 60 officers during 2017. Accordingly the budget for PNC officers (including taxes) will increase to \$518,000 per annum.

A 3rd party will be contracted to supply security services to ABM during project execution and operation phases. This amount is estimated at \$1,514,000 per annum.

21.2.5.3 Information Technology

Due to their remote location, all information communications with the Bisie and Logu sites are transmitted via V-SAT. The data and IT costs allowed are \$148,000 per annum.

21.2.5.4 Community Development

ABM has committed to the establishment of the Lowa Foundation for its Community Development responsibilities. ABM has committed to funding the Lowa Foundation with 4% of its total in-country expenditure. With an estimated annual operating costs of ca. \$100 million, and assuming 60% of these costs will be incurred in-country, the ABM contribution to the Lowa Foundation will amount to \$2,400,000 per annum.

21.2.5.5 Environmental Management Assessments

In terms of ABM's Environmental Management Program (EMP), the company is committed to monitoring the impact of its operations on air quality, groundwater, noise and faunal species. ABM will employ environmental officers to collect data and ensure management adherence to the EMP, however ABM will contract out the quarterly assessments of these impacts to professional external parties. The budgeted environmental management costs are \$164,000 per annum.

21.2.5.6 Environmental Management

The EMP developed for Bisie calls upon ABM to develop and implement plans which mitigate the impact of mining operations on air quality, groundwater quality, noise and faunal species. This will typically be achieved by clean-up and rehabilitation of impacted areas (such as tailings dams and waste disposal facilities) on an ongoing basis. This strategy ensures lower end-of-life environmental rehabilitation costs and ensures that the mine will mitigate its impact on the communities and environment surrounding the mine. An allowance of \$120,000 per annum has been allowed.

21.2.6 Corporate Function, Administration and Supply Chain

21.2.6.1 Corporate Function

The Alphamin Resources Corp. costs are passed on to ABM and include the withholding taxes payable. The function performed by the corporate office ensure compliance with listing and statutory requirements, as well as providing day-to-day management at project and operational level. The budgeted cost for this is \$1,680,000 per annum.

21.2.6.2 Administration

Included under this description are office rental, staff accommodation, DRC licensing fees, audit fees, directors' fees, legal fees and corporate travel. The budgeted allowance for this is \$1,591,000 per annum.

21.2.6.3 Conflict Free Tin Certification

The tin industry in collaboration with EU and American legislators has launched a programme aimed at eradicating links between conflict and minerals in the supply chain to end users. In this regard, ABM will be required to develop protocols to ensure the tin in concentrate is classified as "conflict free" and have these protocols audited by iTSCi on an annual basis. An amount of \$120,000 per annum has been allowed for this audit.

21.2.6.4 Aircraft

The remote nature of the project requires that ABM has access to fixed wing aircraft for the transport of personnel to and from the mine site and also for emergency medical evacuations. In discussions with Busy Bee aircraft operating company, a rate of \$3,000 per flight has been agreed. Assuming ABM charters the aircraft 3 times per week, an annual budget of \$468,000 has been allowed.

21.2.7 Salaries and Wages

The salaries and wages for operational staff is estimated as follows.

Table 21.12 Salaries and wages operating cost

Area	Complement	Total Annual Cost (\$)
Process plant	121	\$898,715
HR	22	\$608,721
DRC Country	14	\$1,142,485
Logistics	29	\$155,110
Finance	31	\$520,092
Services	104	\$892,440
MRM	38	\$1,124,452
Engineering	67	\$578,652
TOTAL	424	\$5,920,667

21.2.8 Haulage and Export Costs

The marketing plan assumes the concentrate will be exported to a smelter for treatment and refining. The off-mine costs have been based on firm tenders from logistics service providers familiar with operating conditions in eastern DRC.

21.2.9 Concentrate Haulage and Shipping

21.2.9.1 Bisie to Logu

The Logu facility will serve as a logistics hub for all incoming and outgoing cargoes and will be managed by ABM. The Logu facility will serve as an interface between the larger capacity 8 wheel drive vehicles used on the Goma-Walikale route and the smaller 6 wheel drive vehicles which ABM will operate between Logu and Bisie. It is envisaged that ABM will have a fleet of three 6-wheel drive vehicles.

The smaller vehicles are proposed for the Bisie-Logu road due to capacity limitations on the timber bridges and steepness of gradient in the design of the Logu-Bisie access road.

The Logu hub will be used to off-load diesel into 80,000 litre bowsers and tranship concentrate into the combined concentrate-diesel containers.

21.2.9.2 Logu to Goma

Using half-height dual purpose containers, 13,000 litres of diesel will be transported on the inbound leg from Goma to Logu and 13.5t of tin concentrate will be transported on the outbound leg from Logu to Goma. These containers will be transported on 8 x 8 rough terrain vehicles and operated by TMK (though other transport contractors may be considered). It is envisaged that TMK will have a fleet of 8-10 of these vehicles which will move into and out of the mine in convoys of 3-4 vehicles so as to reduce security related costs of escorting the product from Bisie to Goma. Over the life of the mine, it is possible that the Goma-Walikale route will be able to accommodate rigid body trucks with 20t payloads. Once this becomes a reality, the container fleet will need to be upgraded to accommodate the larger diesel and concentrate payloads. For the purpose of estimating operating costs, 8 wheel drive vehicles with loads of 13.5t have been assumed.

21.2.9.3 Goma Tin Terminal

A tin terminal, similar in concept to the Richards Bay Coal Terminal, has been conceptualised for Goma. In concept, the tin terminal allows the users of the terminal to access the facilities and obliges them to share in the operating costs. Broadly speaking, the main users of the terminal would be the tin off-take partners (probably 2-off), diesel suppliers and ABM.

The tin off-take partners would each have secure areas in the terminal to consolidate their tin concentrate prior to export. Ownership of the concentrate would pass from ABM to off-taker on delivery of the load to the secure facility. It is envisaged that the tin terminal will be equipped with weighbridge, crane and laboratory for analysis of tin content and deleterious minerals in the concentrate. The tin terminal will be equipped with equipment to tranship the bulk bags into seaworthy 6 or 12m containers which will be loaded onto conventional road going triaxle trucks.

The fuel supplier will be required to fill the combined concentrate-diesel container in the terminal prior to its departure back to Logu.

21.2.9.4 Export

Whilst ownership of the concentrate will pass on delivery to the off-taker at the tin terminal, the DRC exportation requires that ABM clears the concentrate for export. Export documentation clerks will be based at the tin terminal for this task.

The concentrate from Bisie will clear customs through the Bunagana border post, travel through Uganda to Kampala where it can be transhipped onto rail wagon for transport to Mombasa.

The costs associated with haulage are tabled below.

Table 21.13 Haulage costs

Haulage Leg	\$/wmt Concentrate
Rough terrain shunt from Bisie to Goma	333
Logistics hub management fee	4
Haulage from Goma to Mombasa	230
Total	567

21.2.9.5 Shipping

The sealed containers will be loaded onto a conventional container ship in Mombasa. An allowance for the final mile of road transport has been made.

Table 21.14 Shipping Costs

	\$/wmt Concentrate
Shipping charges	22
Final mile haulage	5
Total	27

21.2.10 Export Documentation Costs, Royalties and Taxes

The export of concentrate from the DRC requires authorisation from a number of agencies and the payment of specified local and national taxes. The complexity of the system and volume of paperwork involved result in the appointment of clearing agents.

The following taxes and clearing agent fees are applied to the export of concentrate.

Table 21.15 Export taxes and fees

Department	Description of Tax or Fee	\$ per truck	\$/wmt Conc
Centre d'expérience, dévaluation et de certification (CEEC)	Analytical fees (1% of value)	2,965	110
	Service fees (1% of value)	2,965	110
	Mining royalty (2% of value)	5,929	220
	Certificate of origin	350	13
Office Congolaise Certification (OCC)	Analytical fees	300	11
	Exterior trade office fees	70	3
Division de Mine	Export authorisation fee	150	6
North Kivu Tax	Road tax	100	7
TOTAL		12,829	480

The clearing agent fees are tabled below.

Table 21.16 Clearing agent fees

	\$ per truck	\$/t Concentrate
Clearing costs	450	17
Sundry costs	200	7
Agent fees	450	17
Total	1,100	41

21.2.11 Third Party Contracted services

21.2.11.1 Diamond Drilling

The mine development schedule calls for approximately 660m of footwall drive development per annum. Stope definition drilling cubbies have been planned every 15m and 3 holes will be drilled from each cubby. The average length of each hole drilled is 40m, resulting in 5,280m of underground diamond drilling per annum. A benchmark drilling cost of \$220/m has been allowed which translates into an annual cost of \$1,161,600 for diamond drilling services.

21.2.11.2 Laboratory Services and Assaying

ABM intend outsourcing the management of the laboratory services at Bisie (not the tin terminal laboratory) to a recognised laboratory services contractor with proven track record of operating mining laboratories. Based on benchmark costs from Katanga, an allowance of \$336,000 per annum has been allowed.

21.2.11.3 Feeding Costs and Management of Camp Facility

The operating costs for the accommodation camp have been estimated based on a tendered price submitted by an experienced remote services group, responsible for management of numerous mining camps across the DRC.

Based on a camp population of 420 ABM employees, 200 security contractor employees and 140 mining contractor employees, feeding and management costs have been budgeted at \$2,737,500 per annum.

21.2.12 Sustaining Capital Expenditure

The allowances for sustaining capital expenditure have been made as follows.

21.2.12.1 Mining

The sustaining capital allowance required for the mining operations relates to:

- Replacement of mining fleet;
- Advancing electrical installations as the mining front moves deeper and deeper;
- Installing additional pumping capacity as the mining area increases and forecast in-flow rates of groundwater increase; and
- Efficiency enhancers such as moving workshops or upgrading roadways.

An allowance of approximately \$1.3 million per annum has been made for mining related sustaining capital expenditure.

21.2.12.2 Process Plant

Repairs and replacement of plant mechanical items. These include items such as:

- Front end loaders;
- Crushing, milling and screening equipment;
- Conveyors and pumps;
- Jigs and shaking tables; and
- Thickeners and belt filters.

An allowance of \$1.1 million per annum has been made on the assumption that every 3-5 years the equipment mentioned above will require major repairs, refurbishment or replacement.

21.2.12.3 Infrastructure

An annual allowance for repairs and replacements to

- Goma-Logu road;
- Logu-Bisie road;
- Tailings storage facility; and
- Power generating equipment every 7-10 years.

An allowance of \$0.5 million per annum has been allowed for these items.

21.2.13 Operating Cost Summary

The average annual operating cost estimate for Bisie is summarised below.

Table 21.17 Operating Cost Estimate

Activity	Unit Cost (US\$/t Sn)
Mining	2 909
Processing	348
Site infrastructure	1 394
Power	961
Other	433
Sustaining capital cost	297
Administration and general	1 253
Community development	245
Health, Security & IT	243
Other	765
Logistics cost	1 081
Treatment charges	1 555
Cash cost of tin produced	8 837
Export duties & fees	529
DRC Government royalty	416
Marketing commissions	577
Cash cost of tin sold	10 359

21.3 CLOSURE PROVISION

The closure of the mine will involve dismantling of the process plant, demolition of structures, sealing of the mine shafts, removal of rubble to the waste rock dump, rehabilitation of areas impacted by the operations, rehabilitation of the tailings storage facility, and laying off of the workforce.

Congolese labour law allows for 3-6 months' severance pay for workers made redundant due to operational reasons. Assuming a total workforce of 500 people, the allowance for redundancy pay has been calculated at \$3,300,000.

The rehabilitation costs have been estimated at \$9.50/m². This allows for the demolition of structures, placing 500mm of topsoil over the impacted areas and planting of vegetation. The total allowance for rehabilitation is then \$3,310,000.

Bisie Tin Project

NI43-101



Post closure, an allowance of \$65,000 has been made for active management of the closure process in year 1 and \$33,000 per year for passive management in years 2-5.

The total closure and rehabilitation costs estimated amounts to \$6.81 million.

22 ECONOMIC ANALYSIS

22.1 INTRODUCTION

All figures quoted in this section of the report are based on 100% of the Bisie Project, of which Alphamin Resources Corp. owns an effective 80.75%. The discounted cash flow analysis assumes funding on a 100% equity basis and excludes any financial leveraging effects, as well as any interest expense items that could impact taxable income and/or provide interest deduction tax shields.

22.2 ASSUMPTION AND EVALUATION METHODOLOGY

22.2.1 Evaluation Methodology

The financial evaluation has been performed using real cash flows. No escalation of cash inflows or outflows has been applied in determining the project NPV and IRR.

The evaluation is based on after-tax unleveraged, real internal rate of return (IRR) using end-of-year convention for cash flows in United States Dollars.

22.2.2 Base Date

The base date for the financial model is Q1 2017.

22.3 REVENUE

On-mine revenue is derived from the sale of tin concentrates into the international market place. Revenues are calculated by the tin content of the concentrate less unit deductions, smelting and refining, impurity penalty charges and marketing fees.

22.3.1 Tin Price Forecast

The tin price forecast over the life of mine is \$21,400/t Sn.

22.3.2 Marketing and Treatment Charges

The marketing and treatment charges have been outlined in Section 19.4. Treatment charges of US\$1,555 and marketing commissions of \$577 per ton Sn in concentrate have been applied in the model.

22.3.3 Production and Revenue Summary

Following commissioning of the plant in Q4 2018, production ramp-up is scheduled over Q1 and Q2 2019 with full nameplate capacity being achieved in H2 2019.

Bisie Tin Project

NI43-101



Table 22.1 Annual revenue and cost statistics

Year ending	2017	2018	2019	2020	2021	2022	2023	2024	2025	2026	2027	2028	2029	2030	2031
Sales															
-Tin concentrate sales at CIF selling prices	-	-	222.44	244.75	220.97	200.57	207.60	262.47	213.50	205.63	234.68	309.67	407.25	253.69	142.70
-Treatment charges	-	-	(16.16)	(17.79)	(16.06)	(14.58)	(15.09)	(19.07)	(15.52)	(14.95)	(17.06)	(22.50)	(29.58)	(18.44)	(10.38)
-Logistics costs from Goma export warehouse to CIF	-	-	(4.79)	(5.27)	(4.76)	(4.32)	(4.47)	(5.65)	(4.60)	(4.43)	(5.06)	(6.67)	(8.77)	(5.46)	(3.07)
-Clearing agent fees	-	-	(0.76)	(0.84)	(0.75)	(0.68)	(0.71)	(0.90)	(0.73)	(0.70)	(0.80)	(1.06)	(1.39)	(0.87)	(0.49)
-Export taxes & fees (cost per truck)	-	-	(0.74)	(0.81)	(0.73)	(0.67)	(0.69)	(0.87)	(0.71)	(0.68)	(0.78)	(1.03)	(1.35)	(0.84)	(0.47)
Export taxes & fees (% of net sales value)	-	-	(4.00)	(4.40)	(3.97)	(3.61)	(3.73)	(4.72)	(3.84)	(3.70)	(4.22)	(5.57)	(7.32)	(4.56)	(2.57)
Marketing commission	-	-	(6.00)	(6.60)	(5.96)	(5.41)	(5.60)	(7.08)	(5.76)	(5.55)	(6.33)	(8.35)	(10.98)	(6.84)	(3.85)
Net sales	-	-	189.99	209.04	188.73	171.30	177.30	224.18	182.35	175.62	200.43	264.50	347.85	216.67	121.88
Cost of sales	-	-	(60.99)	(73.14)	(78.23)	(75.49)	(77.98)	(80.96)	(78.23)	(76.65)	(84.10)	(83.21)	(87.31)	(87.65)	(48.03)
-Opening stock	-	-	-	(4.55)	(6.67)	(3.67)	(4.38)	(4.71)	(5.43)	(3.37)	(6.20)	(3.60)	(5.84)	(7.31)	(6.22)
-Mining	-	-	(28.75)	(34.50)	(34.74)	(35.37)	(36.11)	(36.95)	(32.20)	(33.09)	(33.71)	(34.45)	(34.17)	(34.94)	(11.77)
-Processing	-	-	(3.30)	(3.73)	(3.77)	(3.86)	(3.95)	(4.00)	(4.05)	(4.14)	(4.21)	(4.30)	(4.38)	(4.43)	(2.55)
-Site infrastructure	-	-	(12.18)	(13.56)	(13.84)	(14.13)	(14.85)	(15.40)	(15.72)	(17.67)	(18.04)	(18.42)	(18.81)	(19.84)	(11.76)
-Sustaining capital expenditure	-	-	(2.80)	(3.12)	(3.19)	(3.25)	(3.32)	(3.39)	(3.46)	(3.54)	(3.61)	(3.69)	(3.76)	(3.84)	(2.28)
-General & Administration	-	-	(11.84)	(13.17)	(13.45)	(13.73)	(14.02)	(14.32)	(14.62)	(14.92)	(15.24)	(15.56)	(15.88)	(16.22)	(9.62)
-Logistics to Goma export warehouse	-	-	(6.67)	(7.18)	(6.23)	(5.85)	(6.06)	(7.61)	(6.12)	(6.12)	(6.70)	(9.04)	(11.79)	(7.30)	(3.83)
-Closing stock	-	-	4.55	6.67	3.67	4.38	4.71	5.43	3.37	6.20	3.60	5.84	7.31	6.22	-
EBITDA	-	-	129.00	135.90	110.50	95.81	99.33	143.21	104.12	98.97	116.33	181.29	260.54	129.03	73.85

22.3.4 Revenue Inputs and Assumptions

Revenues are calculated in United States Dollars based on a long term metal price of \$21,400/t. Penalties, unit deduction charges, and marketing charges are deducted in calculating the on-mine revenue.

The financial model assumes that 90% of the revenues are received in the month following production, with the balance received 3-months later.

22.4 TOTAL CONSTRUCTION CAPITAL ESTIMATE

22.4.1 Sunk Costs

The total actual historic costs recorded in Alphamin Bisie Mining SA (ABM) financial statements at 31 December 2016 is approximately US\$44 million. This figure has been used in establishing the tax shield applicable to the project. In terms of the DRC tax legislation, 60% of the investment cost can be claimed in the first year following the investment, with the balance being claimed at a rate of 15% per annum.

22.4.2 Owners Capital Costs

From Q1 2016 to Q3 2018, Alphamin will continue to incur costs at an operational and corporate level. These costs have been classified as "Owners Costs" in the Control Budget Estimate. Alphamin has estimated these costs at US\$32.5 million.

22.4.3 Project Execution Capital Costs

The project execution capital costs from Q2 2017 to Q4 2019 have been estimated as US\$118.98 million.

22.4.4 Working Capital

An allowance for US\$0.8 million in working capital and US\$7.1 million in outstanding VAT returns has been incorporated into the peak funding requirements.

22.4.5 Total Construction Capital Costs

Peak funding for the Project, as determined from the period 1 January 2017 to the date upon which the Project starts generating positive operational cash flows on a sustainable basis, is estimated to be US\$152.0 million in nominal terms:

Table 22.2 Project Peak Funding Requirements (Nominal Terms)

PEAK FUNDING REQUIREMENT	US\$M
--------------------------	-------

Project capital expenditure (incl. owners team costs)	155.6
VAT	7.1
Working capital	0.8
Cash generated by operations	(1.5)
Project peak funding	162.0
Less cash on hand	(8.0)
Less funds due from minority shareholders	(2.0)
Peak funding requirement	152.0

22.5 OPERATING COSTS

The total operating costs are tabled below.

Table 22.3 Operating Cost Estimate

Activity	Unit Cost (US\$/t Sn)
Mining	2 909
Processing	348
Site infrastructure	1 394
Power	961
Other	433
Sustaining capital cost	297
Administration and general	1 253
Community development	245
Health, Security & IT	243
Other	765
Logistics cost	1 081
Treatment charges	1 555
Cash cost of tin produced	8 837
Export duties & fees	529
DRC Government royalty	416
Marketing commissions	577
Cash cost of tin sold	10 359

22.6 TAXES AND ROYALTIES

Under the special dispensation of the Code Minier, corporation taxes of 30% apply to mining companies. These taxes are levied post amortisation of the pre-production capital expenditure.

A minimum tax of 1% of turnover applies to mining companies during the amortisation period.

A National 2% royalty on gross revenues applies to the sale of tin in concentrate.

22.7 NET PRESENT VALUE SUMMARY

The results of the evaluation are presented below.

Table 22.4 Net Present Value Summary

Discount Rate	Net Present Value (US\$ millions) at Sn Price		
	US\$ 19,000/t	US\$ 20,000/t	US\$ 21,400/t
8%	301.0	343.2	402.2
10%	250.7	287.7	339.5
12%	209.2	241.8	287.4
15%	159.5	186.8	225.0

The project IRR is 49.1%.

22.7.1 NPV Sensitivity

The sensitivity chart below shows the NPV (at 8% discount factor) variation due to changes in revenue, capital and operating costs, holding all other inputs constant.

Figure 22.1: Project NPV sensitivity

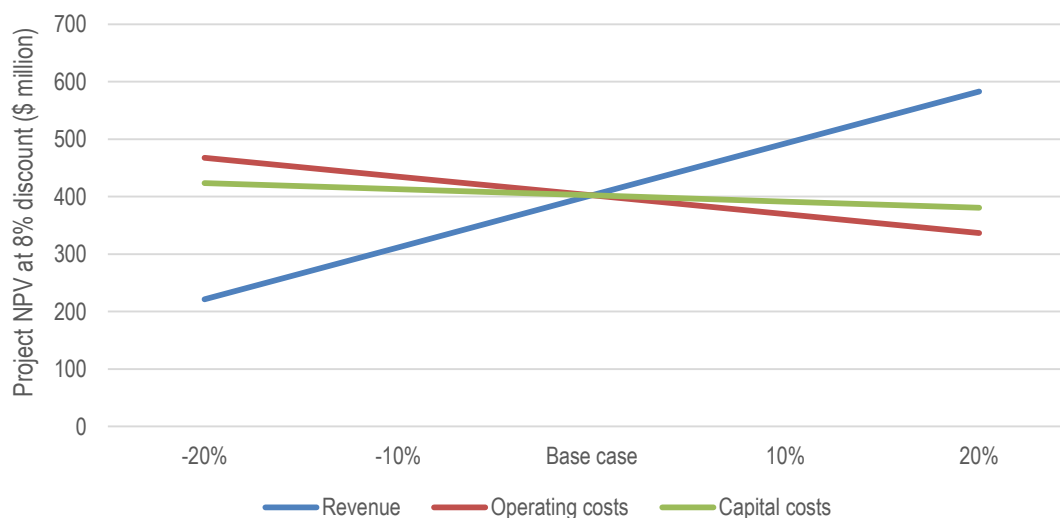

22.8 PAY BACK PERIOD

The payback period following construction is forecast at 17 months.

22.9 MINE LIFE

The operating mine life of the Bisie Project, based on the Mineral Reserves as declared in this report is 12 years. This includes the initial production ramp-up but excludes project construction, pre-production and mine closure activities.

Extending the life of the mine would rely on the conversion of inferred resources to reserves and the discovery of additional resources within the current mining permit area.

23 ADJACENT PROPERTIES

There are no adjacent properties of relevance.

24 OTHER RELEVANT DATA AND INFORMATION

24.1 PROJECT EXECUTION PLAN

24.1.1 Programme Planning and Scheduling

The proposed Project development schedule allows 21 months for the mine construction programme. A high level project execution schedule is illustrated below.

Figure 24.1 Project Execution Schedule

Activity	F2017				F2018				F2019			
	Q1	Q2	Q3	Q4	Q1	Q2	Q3	Q4	Q1	Q2	Q3	Q4
Construct access road	█											
Mine construction			█		█				█			
Plant construction					█							
Commissioning								█	█			
Ramp-up to full production									█			
Steady state production											█	

24.1.2 Commissioning and Handover

Commissioning for the project is expected to take three (3) months as outlined in the high level execution schedule. A key aspect of the project commissioning is the alignment with the ramp-up of mining production and the availability of sufficient feed material on the RoM stockpile. This will be managed through interaction with the mining contractor during the execution phase.

Commissioning of the plant has been planned in phases as follows:

- C1 - Mechanical completion, Electrical completion, Civil works completed;
- C2 - Mechanical cold commissioning and electrical direction testing;
- C3- Wet commissioning (water flow through plant);
- C4 - Slurry commissioning;
- C5 – Performance testing; and
- C6 - Contract closure.

24.1.3 First Fills

First fills provide for start-up consumable inventories which are required for the plant to operate. Due to the small amounts of reagents consumed within the plant, the first fill reagents will be enough to operate the plant for 4 to 5 months. The first fill of reagents required when commissioning the plant have been allowed for in the capital cost estimate.

24.1.4 Commissioning spares

Due to the remote location and road access issues during the rainy season an allowance for commissioning, critical spares and 2 year operational spares were included within the capital cost estimate.

24.1.5 Project Completion and Transfer

On successful completion of the hand over certificates for each section of the plant, operational and maintenance responsibility will revert to plant operations. Any particular warranty periods will then commence.

24.2 SECURITY

24.2.1 Overview

During the Congo wars from 1996 to 1997 and 1998 to 2003, the conflict involved nine countries and more than 40 armed groups. Two main categories of armed groups operated in eastern Congo: the Rwandan Hutu FDLR and the Rwanda and Uganda-backed M23. The M23 was defeated by the FARDC in conjunction with MONUSCO's Force Intervention Brigade in November 2013. Elements of FDLR are still operational in the far east of the DRC. After the Congo wars a number of self-defence arrangements and opportunist armed groupings remained. These groups typically operate in logistically challenging areas, where the National Security Forces are constrained in acting against them.

Armed groups are defined as having the potential to employ arms in the use of force to achieve political, ideological or economic objectives. They are not within the formal military structures of States, State-alliances or intergovernmental organizations. Armed groups are not under the control of the State(s) in which they operate and can include: rebel movements, ethnic militias, and economic and military entrepreneurs. It is the latter two that are predominantly operational in the areas of Alphamin's activities.

Specific to the eastern DRC are groups known as Mai Mai. The Mai Mai is a loosely grouped collection of Congolese militia operating in eastern Congo

24.2.2 Armed Groups Operational in the Area

Information contained in this report has been obtained from the Group of Experts report on the Democratic Republic of the Congo established pursuant to United Nations resolution 1533 (2004). The following figure will provide the reader with reference for the geographic locations of the armed groups relative to the Bisie mine site.

Figure 24.2: Rebel groups active in the greater Walikale area

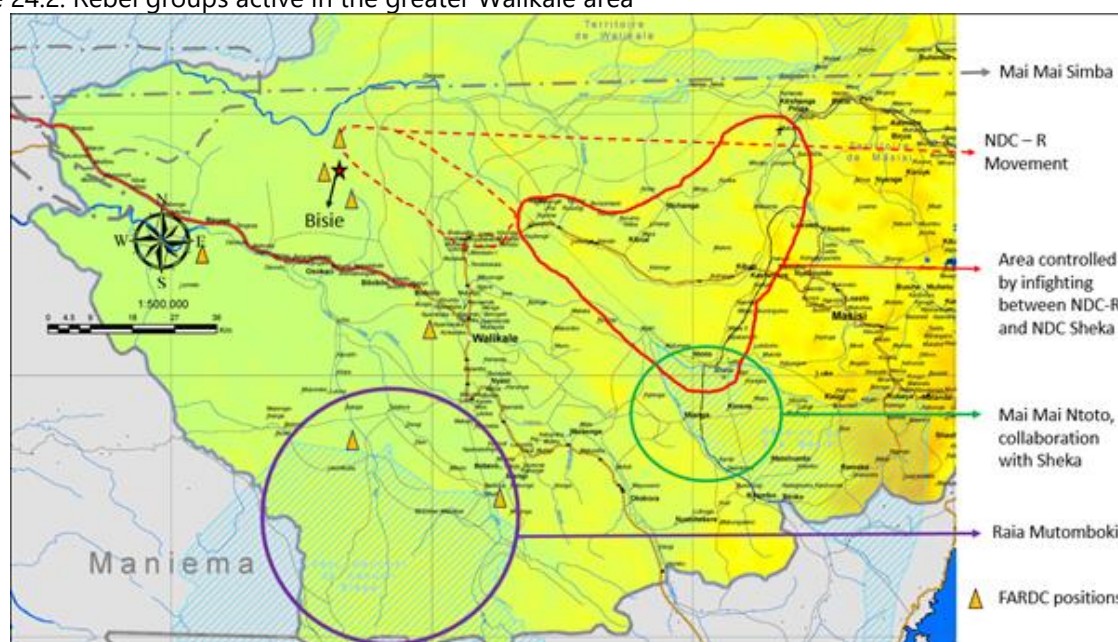

Source Alphamin

24.2.3 NDC Sheka

Nduma Defence for Congo (NDC Sheka), otherwise known as Mai Mai Sheka, is a majority ethnic Nyanga Congolese armed group founded in 2009 by a former civilian mineral trader, Sheka Ntabo Ntaberi.

According to NDC documents obtained by the United Nations, NDC has 32 officers and a total of around 100 combatants.

In 2011, Sheka entertained Government requests for negotiating his integration into FARDC. General Amisi Kumba, known as "Tango 4" met with a delegation of NDC Sheka officers and its spokesperson, Sheka's uncle, Bosco Katende. The delegates' approval of the Government offer was overridden by Sheka's insistence on specific modalities, owing in part to Sheka's fears over the judicial consequences of his command responsibility for the Kibua-Luvungi rapes of July to August 2010, leading him to seek an amnesty as a top priority.

During the United Nations current mandate, Sheka has not been the object of any FARDC military operation, nor has it conducted any large-scale pillaging attacks on civilian villages or mining towns as it routinely did in Bisie, Mubi, Njingala, Kilambo and Omate in 2009 and 2010.

NDC Sheka controls more than 30 remote gold mines throughout Ihana and Utunda groupements north of the Goma-Walikale axis where diggers work and produce gold directly for the groups. NDC Sheka also imposes an additional production tax of either 10 per cent of output or a fixed amount of gold per an allotted period of time. In addition, NDC Sheka ensures the payment of customary taxes to traditional leaders who support it.

Socagrimines, a mining company operating in the large gold mine of Omate, has reached an agreement with Sheka in exchange for security guarantees. According to the local population, "Colonels" Alba and Guidon have asked miners at Omate to pay weekly quotas of gold.

Socagrimines is also present at the Mungwe mine east of Omate, where NDC has an established presence.

While most of the financial profits of NDC are drawn from the gold trade and the extortion of tin ore traders, the United Nations has found that Sheka also controls a number of diamond-mining locations north of the Oso River. While diamond production can be sporadic, profit margins are high.

NDC Sheka position of influence and power within in these areas, has over the period of 2015, greatly diminished, with Sheka himself being wounded in clashes on several occasions.

Much of the demise of NDC Sheka can be attributed to the ongoing internal conflict he has had with his once Second-in-command (2 IC), namely Muisa Shimiray Guidon (Guidon/Gedeon/NDC–R).

NDC Sheka has attempted to forge alliances with other smaller Mai Mai groups, but to a larger extent this has failed and he is caught in a battle between keeping his own force mobile against the likes of Guidon, but also fighting the forces loyal to the FDLR (Forces démocratiques de libération du Rwanda)

24.2.4 Mai Mai Simba (Mai Mai Simba Kachimuka)

Mai Mai Simba is the oldest Congolese armed group active in the Democratic Republic of the Congo today, with its origins dating back to the Mulele revolution in 1964. Ex-combatants claim that the official name of their movement is Armée populaire de libération nationale congolaise-Lumumba. With strong local roots in Lubutu territory in Petro William, maintains contacts with former Lumumbist revolutionaries in Kinshasa. Mai Mai Simba is based in the mineral-rich forests of the Maiko Park, with positions extending across North Kivu, Maniema and Orientale Provinces. Led by “General” Mando Mazero, the group numbers between 200 and 300 combatants. They have been avid poachers of elephants, having supplied Kisangani with large quantities of ivory for decades. The illegal exploitation of tin ore, gold and diamond deposits within Maiko National Park is another main focus of Mai Mai Simba.

Mai Mai Simba also collaborates with the Mai Mai group of “Colonel” Luc near the important mining zone of Oninga, in northern Walikale. According to United Nations observers, the group has disputed control over certain Walikale mines outside Maiko National Park with Sheka’s NDC, notably at Sous-Sol.

All of Mai Mai Simba’s gold is also taxed by FARDC criminal networks operating under the direction of Beni sector Commander Colonel Eric Ruhorimbere who has deployed small units tasked with erecting roadblocks along the road from Butembo to Manguredjipa. Mineral traders concur that after reaching Butembo, all the gold purchased from areas under the control of Mai Mai Simba is eventually sold to buyers in Kampala.

References to the Mai Mai Simba are sometimes reported as being that of the Mai Mai Morgan group (whose leader Paul Sadala was killed in 2015) and vice versa, due to previous convergence of common interests,

24.2.5 Raia Mutomboki

Traditionally an armed group that dominated the Shabunda territory of the South Kivu province, the RM (Raia Mutomboki) have branched out into areas of the North Kivu province as well.

Currently the most common groups are RM Mirage, RM Akilo and to the south near Shabunda, RM Takulengwe.

Their style to fragment and proliferate has been likened to a “franchise business” with the local RM group taking on a leader’s or areas name. The movement has been bolstered (like many armed groups) by the arrival of a number of demobilized soldiers and deserters.

The true intentions and objectives or political ideals of the RM have seen to have been lost over the years, with the RM becoming more notable as traffickers and generally involved in banditry and harassment.

There has been no clear move to disarm and dissolve the RM factions that can be compared with the DRC government’s recent attempts to dissolve the last pockets of FDLR in the Kivu’s. However, during 2015, FARDC forces did concentrate on dislodging RM elements from the southern part of Walikale that borders Shabunda territory.

24.2.6 Mai Mai Groups of Ntoto

The general area of Ntoto is populated by a cluster of Mai Mai groups, varying in size and activity. For the most part inactive and localised, the clashes between FDLR/FARDC, NDC-R/NDC Sheka and these groups against the FDLR, has drawn these smaller “auto defence” groups in to these larger clashes.

This cluster is made up of the Mai Mai Kifuafua, MAC, Mai Mai Ntoto and FDC – Guides.

The Mai Mai Kifuafua being possibly the more dominant of the groups, under the leadership of a certain Delphin Mbaenda.

These groups shift in and out of alliances with each other and the government forces.

24.2.7 NDC Guidon (NDC-R/NDC Gedeon)

Nduma Defence for Congo – Guidon is a splinter group from the NDC – Sheka Mai Mai group.

The group is led by Mwissha Shimirya Guidon, the once second in command of operations and intelligence for the NDC Sheka group. He was also the second in command directly to Sheka.

Guidon deserted from the FARDC when Sheka founded the NDC, and had been his military commander ever since.

However in early 2015, internal disputes came to ahead and the two split, confronting each other in violent clashes.

Guidon quickly established himself and has taken over swathes of areas once dominated by Sheka.

Guidon has indicated that he wishes to be integrated back into the FARDC and demobilise his people. The group is currently aligned with government forces in operations against the FDLR.

24.2.8 Conflict Free Tin Initiatives Reduces Value Of Stolen Tin

The tin industry has actively developed initiatives to prevent conflict minerals entering the supply chain. These initiatives have been developed in tandem with:

- United States of America legislation under the Dodd-Frank Act;
- OECD Due Diligence Guidance for Responsible Supply Chains of Minerals from Conflict-Affected and High-Risk Areas; and
- The International Conference for the Great Lakes Region.

Through the initiatives, the industry has recognised the issue of illegal mining and the ability of armed groups to source financing from the production and trade of minerals in the Great Lakes Region. Within the industry, burden of proof falls primarily on supply chain operators to prove the direct source of the cassiterite produced for smelting. That material which is not traceable to its direct source becomes unsellable in the open market.

The complexities of certifying stolen cassiterite make the product less appealing to armed groups and so reduce the risk of an attack on the mine with the intention to steal final product.

24.2.9 Alphamin Bisie Mining Security Plan

STRATEGIC SECURITY PLANNING

The objective of the Alphamin Bisie Mining SA (ABM) strategic security plan is to effectively manage the security risks in a collective and proportionate manner to achieve a secure and confident working environment. The mandate of the security department is as follows:

- Protecting ABM employees and assets;
- Continuously reducing the number and severity of security incidents;
- Continuously reducing adverse incidents of all types involving people and property;
- Preventing injuries to its employees and contractors;
- Protecting ABM's information;
- Protecting ABM and Alphamin Resources reputation and that of their investors; and
- Safeguarding the future of ABM.

24.2.10 Guiding Principles

In completing its mandate, the security department follows two main internal standards and guidelines, namely;

- ABM Corporate Security Framework; and
- ABM Mine Site Security Procedures.

These guidelines and operational procedures are supplemented with external and internationally qualified standards and guidelines, namely;

- Voluntary Principles on Security and Human Rights;
- ASIS International Standards and Guidelines;
- UN Standards and Guidelines on the use of force, firearms; and
- UN Standards and Guidelines for law enforcement officers and security practitioners

24.2.11 Partnerships

To achieve and execute its security strategy, the security department will work closely with the following partners:

- PNC
- FARDC
- UN (MONUSCO)

Complementing the DRC State security structures and the United Nations will be the collaboration with security departments of other mining companies and major NGO role-players in the area.

24.3 LOGISTICS

24.3.1 Road Infrastructure

Alphamin has constructed a 32km access route from the village of Logu to Bisie. The project is accessible by rough terrain vehicles from Goma and regular trips are made several times per week to supply the necessary food, fuel and other supplies required at Bisie.

The road is being upgraded to allow underground mining equipment to access the project site.

Figure 13.1 Upgrading of Logu-Bisie Access Route



Source: Alphamin

The access road will link Bisie to National Route 3 (N3) that runs between Kisangani and Bukavu with additional linkages from the N3 to Goma. The potential access routes to Bisie are illustrated below.

Figure 24.3 Project Access Route Options

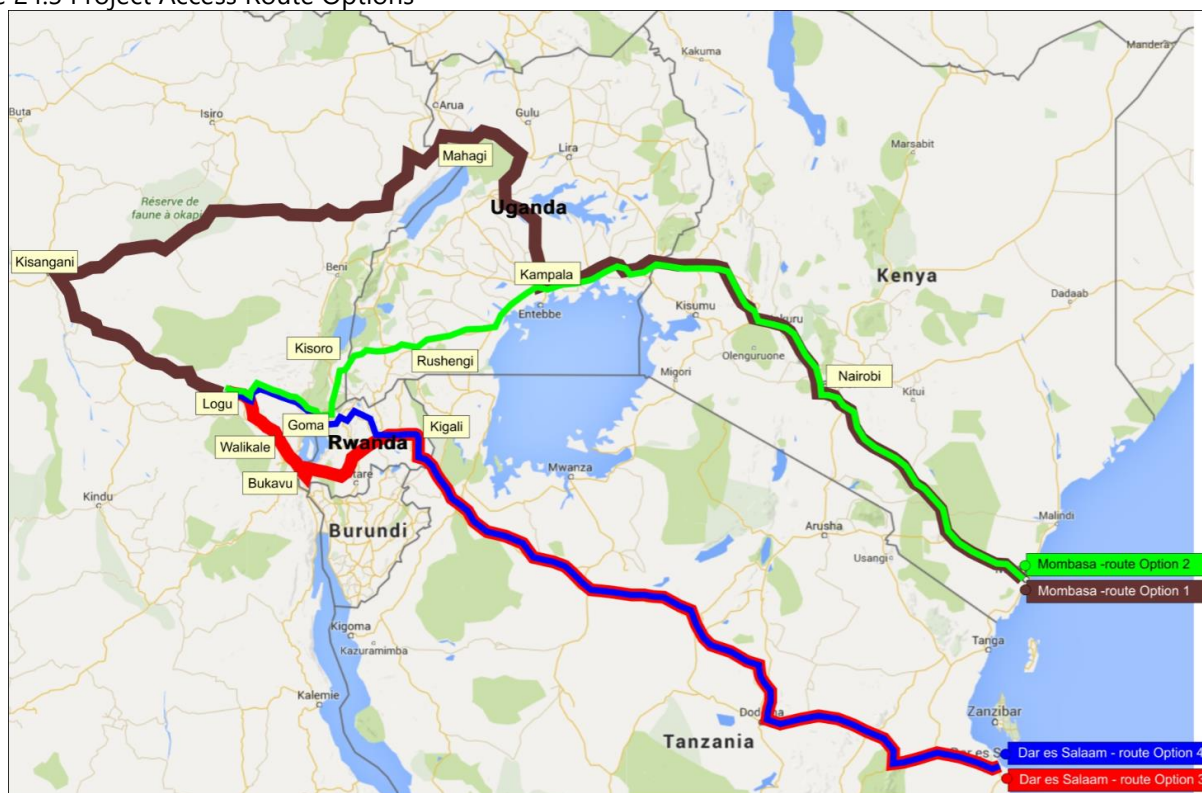

Source Alphamin

The distances associated with each access route are tabled below.

Table 24.1 Access Route Road Freight Distances

Route	Way-Points	Distance
Option 1	Mombasa-Nairobi-Kampala-Mahagi-Kisangani-Logu-Bisie	2 295km
Option 2	Mombasa-Nairobi-Kampala-Rushengi-Kisoro-Goma-Logu-Bisie	1 925km
Option 3	Dar es Salaam-Nyerabanda-Bujumbura-Bukavu-Walikale-Logu-Bisie	1 765km
Option 4	Dar es Salaam-Kigali-Goma-Walikale-Logu-Bisie	1 800km

24.3.2 Project Construction Phase Volume Estimate

From the engineering designs, Material Take-Off (MTO) lists have been prepared and the estimated mass/volumes for steel, piping, electrical, mechanical, civil and other items have been calculated. In establishing the construction phase transport volume, a 50% load factor has been applied to the total mass of material required for plant erection (to account for the “air” that is transported due to packing inefficiencies). In this way it is estimated that 555 containers (6m length) will be required to deliver the materials essential for plant erection.

24.3.3 Origin of Goods

The main source of material, equipment and consumables will be South Africa. With Alphamin’s EPCM contractor being based in Johannesburg, Johannesburg will be the main consolidation point for packing of containers prior to delivery to Bisie.

Due to the condition of the roads in the DRC and the requirement to use all-terrain vehicles for final delivery, only 6m containers will be used for delivery of project equipment and materials.

24.3.4 Project Phase Transport Strategy

The packed 6m containers from Johannesburg will be transported to Durban and exported through the Durban Port Terminal. Both Dar es Salaam and Mombasa can be used as landing ports. Both ports offer reasonable charges, storage facilities and volume handling capabilities.

The 6m containers will be transported from port to Goma via standard tri-axle truck. In Goma, the containers will be offloaded from the tri-axle trucks and loaded onto an 8x8 rough terrain vehicle for the final leg of the journey to Bisie.

Figure 24.4: Typical rough terrain vehicle used for final leg transport



Source TMK

24.3.5 Operations Phase Transport Strategy

24.3.5.1 Goma-Bisie Leg

The in-bound consumable requirements for Bisie have been estimated as follows

- Diesel fuel - 650,000 litres of fuel per month for the power generation and mobile equipment fleet at the mine. At a density of 0.83kg per litre, this equates to 540 tons of fuel per month;
- Reagents and grinding media- estimated at 3-4t per month;
- Explosives –estimated at 21t per month;
- Mine support –estimated installation of 20t roofbolts and associated steel products as roof support per month; and
- Other – Miscellaneous items such as food, stationary, cement, lubricants and spare parts.
- At full production, the inbound logistics requirements will be approximately 600t per month.

Assuming an average weight of 11t per container, the mine will require 55 in-bound container loads per month.

The outbound requirements are driven by the volume of concentrate produced and its moisture content. Assuming a 61%Sn contained in concentrate and 10% moisture content, the outbound logistics requirement is 1,500t per month. Loading 14t of concentrate per container will require 107 out-bound container loads per month.

24.3.5.2 Goma-Port Leg

In Goma the concentrate will be transferred to a standard tri-axle truck and transported to either Mombasa or Dar es Salam.

24.4 TAILINGS STORAGE FACILITY AND MINE RESIDUE

Three streams of mine residue (or waste) reporting from the Process Plant and the mine, require storage within the licence area. The residues requiring storage are:

- Waste rock from the underground mining works, trucked to site;
- Slurry Tailings (Spiral Tailings) (<1mm) hydraulically pumped from the Process Plant; and
- Coarse, Dry Tailings (Jig Tailings) (1-10mm) trucked from the Process Plant.

A site selection study was undertaken on the 2 residues reporting from the Process Plant. Once this was completed the third stream (waste rock) was included in the scope. However, it was determined that the selected site could accommodate all three residues.

A Residue Disposal Facility (RDF) was designed to accommodate all 3 residues for the design life of the mine. The RDF includes:

- A Tailings Storage Facility (TSF) for the Spiral Tailings,
- Waste rock and Jig Tailings Storage Facility or Dry Waste Dump (DWD), and
- Associated Infrastructure (Sumps, access roads, etc.)

24.4.1 Design Criteria

The design criteria for the RDF are summarised below.

Geotechnical laboratory tests were carried out on a single sample of Jigs and Spiral Tailings by Geostrada (Pty) Ltd (*Geostrada*). Paterson & Cooke (Pty) (*P&C*) Ltd carried out settlement tests to determine the Spiral Tailings placed densities.

Table 24.2 Residue Disposal Facility Design Criteria

Item	Criteria	Value
1	Ore type	Tin
2	Design Life of Facility	10.5 years
3	Average Residue Deposition Rates:	
	Jigs (Coarse) Tailings	243 000 tpa
	Spiral (Slurry) Tailings	73 800 tpa
	Waste Rock	93 500 tpa
4	Solids Specific Gravity:	
	Jigs (Coarse) Tailings	3.196
	Spiral (Slurry) Tailings	3.14
	Waste Rock	2.8 – 3.0
5	Particle Size Distribution:	
	Jigs (Coarse) Tailings	1 - 10 mm
	Spiral (Slurry) Tailings	< 1 mm
	Waste Rock	< 400 mm
6	% solids to water ratio (by mass):	
	Jigs (Coarse) Tailings	90%
	Spiral (Slurry) Tailings	50%
7	Delivery Method:	
	Jigs (Coarse) Tailings	Trucked
	Spiral (Slurry) Tailings	Pumped
	Waste Rock	Trucked

24.4.2 Characterization of Tailings and Waste Rock

Particle Size Distribution

The particle size distribution of the Jig and Spiral Tailings, determined by Geostrada, is depicted in Figure 24.5 below.

The grading of the Jig Tailings can be described as follows:

- Maximum particle size 10mm;
- 59% passing 4.75 mm sieve;
- 6% passing 0.075 mm sieve.

The grading of the Spiral Tailings can be described as follows:

- Maximum particle size 0.6mm;
- 40% passing 0.075 mm sieve;
- 26% passing 0.038 mm sieve.

The waste rock from the underground mine will have a maximum size of 400mm, according to the mining consultant, Bara Consulting (Pty) Ltd (*Bara*).

Figure 24.5: Particle size distribution curve of expected tailings products

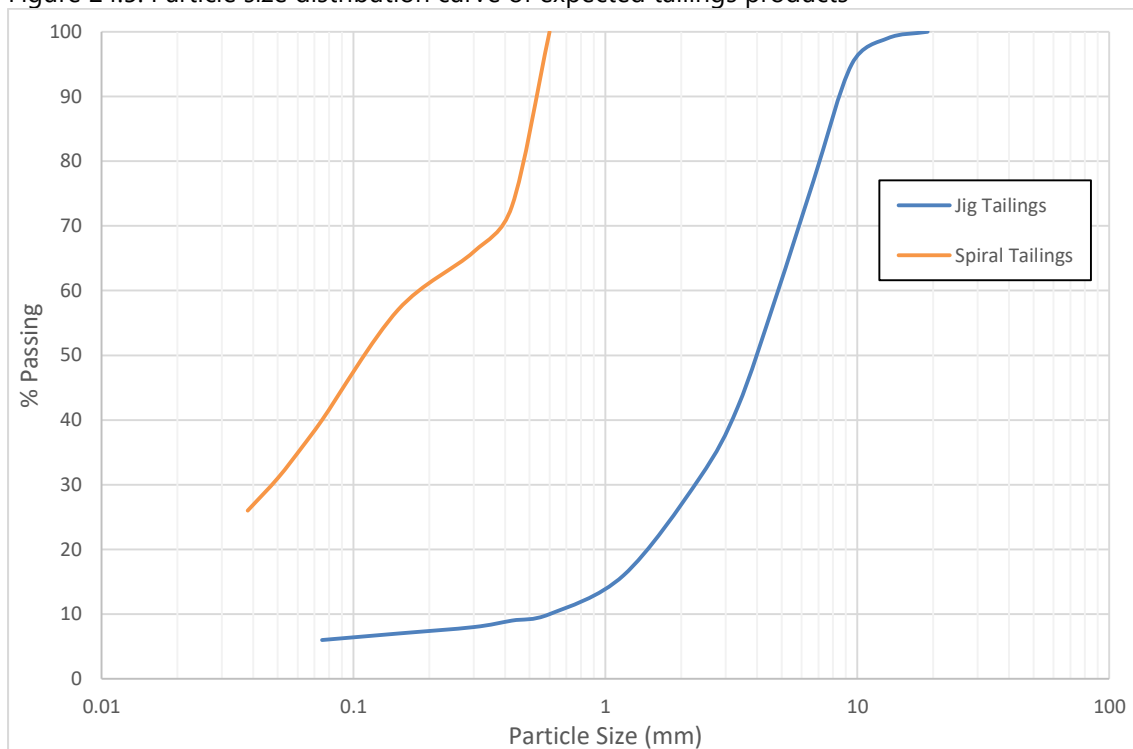

24.4.3 Estimated Placed Tailings and Waste Rock Density

24.4.3.1 *Spiral Tailings*

The estimated placed dry density of the Spiral Tailings was determined using the particle Specific Gravity (SG) of the tailings and laboratory test results. Four tests were carried out on the tailings sample. Each test simulates the different conditions associated with the deposition of tailings from the perimeter of the TSF in order to ascertain the tailings placed dry density under each condition.

- The undrained settling test simulates conditions below the pool at the centre of the TSF. A dry density of 1.3 t/m³ was achieved.
- The drained settling test simulates the conditions near the pool, where tailings are constantly wet. A dry density of 1.3 t/m³ was achieved.
- The undrained evaporation test simulates beach conditions with evaporation. A dry density of 1.5 t/m³ was achieved.
- The drained evaporation test simulates the outer beach conditions with evaporation. A dry density of 1.6 t/m³ was achieved.

The average dry density is thus 1.425 t/m³. However it is Epoch's experience that the average in situ void ratio of tailings is usually approximately 1, which results in a dry density of 1.57 t/m³. Therefore a density of 1.5 t/m³ was used in the design.

24.4.3.2 Jig Tailings

The placed density of the Jig Tailings was determined by Geostrada, who performed a lightly compacted dry density test. This resulted in a dry density of 1.993 t/m³. In order to ensure a conservative design as only one sample of Jig Tailings was tested, a placed density of 1.8 t/m³ was used.

24.4.3.3 Waste Rock

The Specific Gravity (SG) of the waste rock from the mine varies between 2.8 and 3.0. According to literature, the void ratio of waste rock is between 0.3 and 0.6. Epoch has used 0.6, therefore a placed density of 1.9 t/m³ was used in the design.

24.4.4 Site Selection Study

A site selection study was undertaken to locate an appropriate site for the TSF. The study is documented in Epoch's report. The requirements of the TSF at the time of the site selection study were as follows:

- Spiral Tailings comprising a total of 590 kt and pumped to the TSF; and
- Jig Tailings comprising a total of 1944 kt and trucked to the site.

Three sites were identified for the Spiral Tailings and two sites were identified for additional Jig Tailings storage. The following describes the sites identified:

- **TSF 1:** This site was a valley impoundment dam South-West of the proposed portal and could contain the entire capacity of Spiral Tailings and had sufficient area for expansion downstream of the containment wall for Jig Tailings storage;
- **TSF 2:** This site was situated West of the portal and provided containment for the Spiral Tailings and the Jig Tailings downstream of the containment wall;

- **TSF 3:** This site was situated North-West of the portal and provided containment for the Spiral Tailings and partial containment of the Jig Tailings;
- **TSF 4:** This site was the southernmost site relative to the portal and provided a partial containment option for the Jig Tailings; and
- **TSF 5:** This site was situated directly north of TSF 3 and may be used in conjunction with TSF 3 to provide a full containment option for the Jig Tailings.

Figure 24.6: Site Selection TSF options

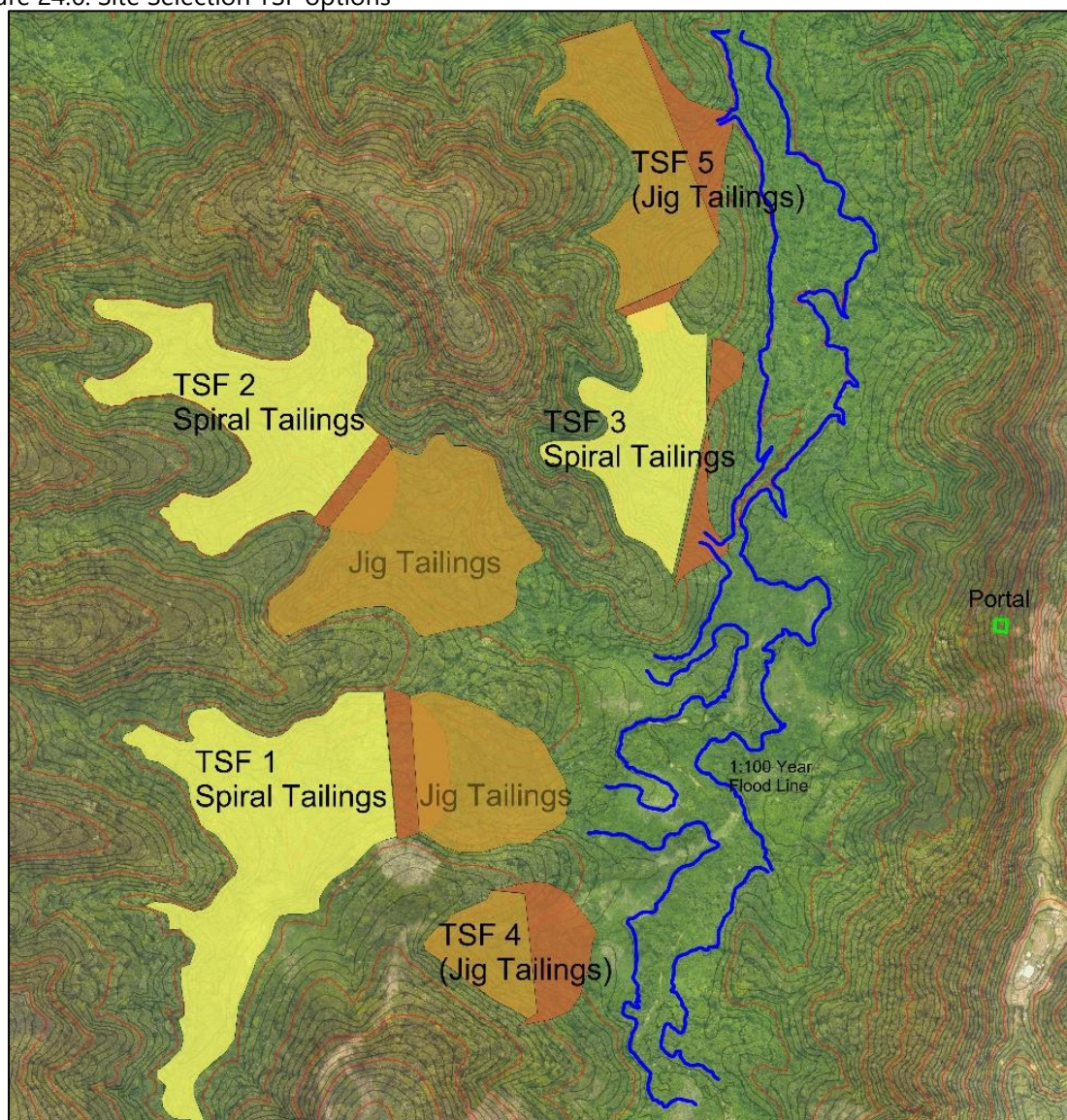

Source Epoch

Each site was analysed according to the following criteria:

- Storage capacity of each site based on the topography;
- Rainfall catchment area;

- Footprint area, in terms of the area required to be cleared and number of trees to be felled;
- Distance to Process Plant, in terms of the distance required to truck Jig Tailings to the site and/or pump Spiral Tailings; and
- Potential risks associated with each site in terms of:
 - Safety;
 - Public Health;
 - Environmental Impact; and
 - Other Issues (Social, further capacity, etc.).

Each site was assigned a risk rating based on the above potential risks.

The results of the study were as follows:

- All sites were capable of providing the required storage for the Spiral Tailings and where necessary TSF 4 and TSF 5 could be used to contain the balance of the Jig Tailings;
- TSF 1 and TSF 2 were found to have very large catchments and it would be expensive to provide the required storm water diversion. TSF 3 had the smallest catchment;
- TSF 3 had the smallest footprint areas, however it would require TSF 4 or TSF 5 to contain the Jig Tailings. TSF 1 and TSF 2 had the largest footprint areas and would be capable of providing storage for the Jig Tailings as well;
- TSF 3 was the closest to the Process Plant and therefore the cheapest option in terms of haulage and pumping costs; and
- TSF 3 was found to have the lowest risk due to the site being downstream of the Process Plant and would not affect the Process Plant in the case of a failure.

To conclude it was found that TSF 3, in combination with TSF 5 would be selected for the RDF site. The waste rock was included in the scope subsequent to the site selection study, however it was determined that there would be sufficient capacity to include the waste rock at TSF 5.

24.4.5 Seepage and Slope Stability

Slope stability of the side slopes of the TSF and the DWD were evaluated by means of a limit equilibrium method software package known as Slope/W, which forms part of the GeoStudio suite. In the case of the TSF, which contains a hydraulically delivered tailings stream, a seepage analysis was conducted with Seep/W in order to determine the location of the phreatic surface and its impact on the Factor of Safety of the TSF impoundment wall. This chapter aims to establish the principles which were complied with during the necessary analyses.

Critical sections were selected based on the configuration of the facilities and based on the results of the geotechnical investigations. The seepage and slope stability analyses made it possible to

evaluate and assess the geometry and configuration of the facilities and their associated Factors of Safety against the acceptable standards and criteria for long-term stability in the DRC.

Figure 24.7: Position of critical sections through the TSF and DWD

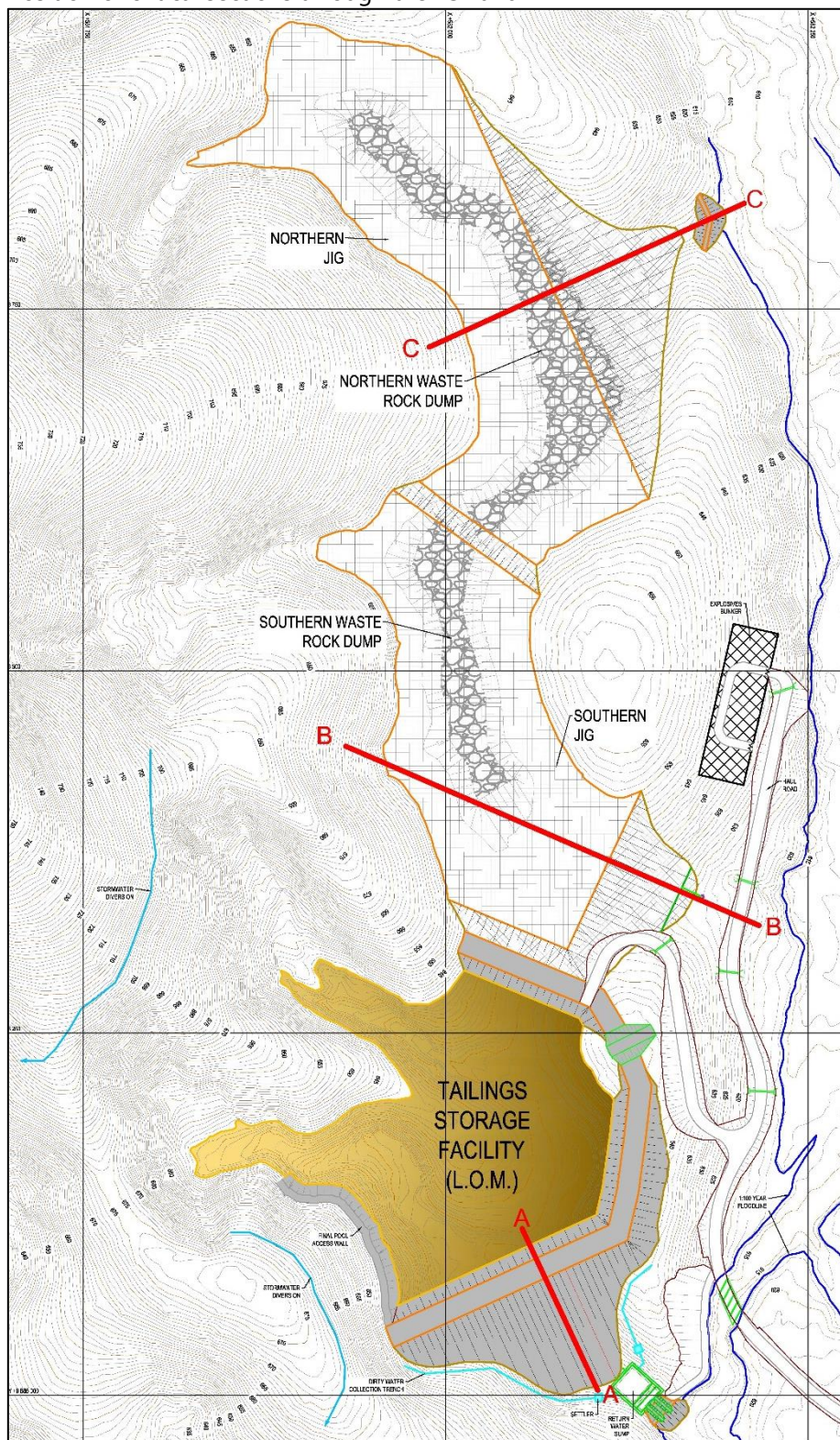

Source Epoch

The slope stability analyses have been undertaken to consider both static and pseudo-static conditions. Static conditions determine the Factor of Safety (*FoS*) without considering any seismicity, while pseudo-static assesses the *FoS* in the event of a simulated design Peak Ground Acceleration (PGA). A PGA of 0.11 g (10% probability of being exceeded in a 50 year period, or an annual probability of exceedance of 1 in 475) was used based on the location of the site relative to recorded seismicity in the DRC (Tuluka, 2012).

24.4.6 Seepage Analyses of the TSF

Section A-A as indicated in Figure 24.6 as selected as the critical section with which to analyse the slope stability and seepage regimes of the TSF. The configuration of the seepage model through Section A-A is provided below.

Figure 24.8: Physical configuration of the TSF seepage model through Section A-A

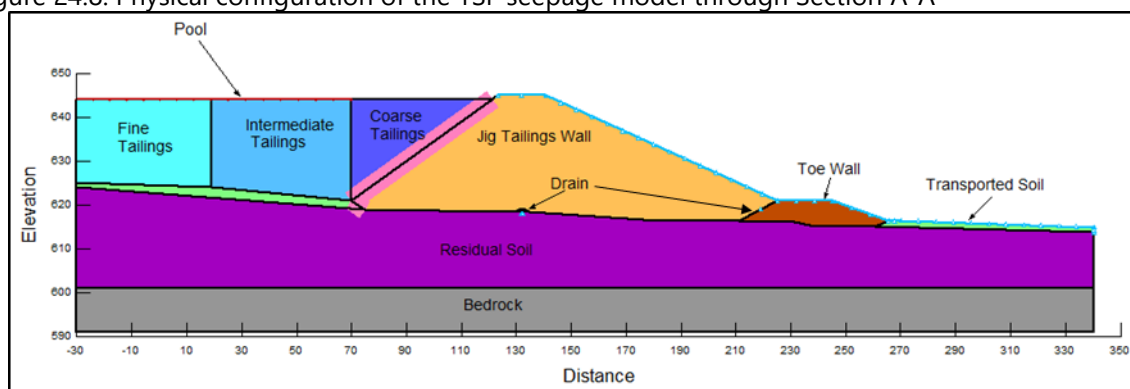

Source Epoch

The Table below lists the hydraulic conductivities and the material type for each of the regions indicated in Section A-A.

Table 24.3 Residue Disposal Facility Seep Input Parameters

Region	Material	Hydraulic Conductivity (m/s)
Fine Tailings	Spiral Tailings	3.0×10^{-8}
Intermediate Tailings	Spiral Tailings	5.8×10^{-8}
Coarse Tailings	Spiral Tailings	1.4×10^{-7}
Wall	Jig Tailings	1.1×10^{-7}
Toe Wall	In-Situ Soils	1.3×10^{-6}
Drain	Coarse Jig Tailings	1.3×10^{-7}
Transported Soil	Silty Clay	1.7×10^{-6}
Residual Soil	Weathered Granite	3.6×10^{-8}
Bedrock	Granite	Impermeable

Four possible scenarios were considered for the analysis based on various operating conditions:

- Extended pool with functional drains;

- Extended pool with non-functional drains;
- Normal operating pool with functional drains (expected normal operational scenario); and
- Normal operating pool with non-functional drains.

The models indicate that the functional drains are effective at drawing down the phreatic surface through the TSF wall in both the extended and normal operating pool sizes. Without the functionality of the drains, the models indicate that a higher phreatic surface will exist in the TSF wall and more seepage will occur through the downstream toe of the wall.

The seepage models were used as the parent models on which the slope stability was analysed.

24.4.7 Slope Stability analyses of the TSF and DWD

Slope stability analyses of the TSF and the DWD were carried out using Slope/W to determine the FoS of the critical slip surface based on the search parameters in the software, the material properties and the phreatic surface. Once the critical slip surface has been established, it is possible to conduct a probabilistic analysis which takes into consideration the possibility of varying material properties to determine the Reliability Index and Probability of Failure.

24.4.8 Acceptable Factor of Safety

The following DRC legislative requirements in terms of the static stability of TSF and DWD side slopes were taken into account: Stability calculations shall take into consideration long-term conditions that might affect the structures, by taking into account the static and pseudo-static loads. The Table below summarises the DRC legislative requirements in terms of the required minimum FoS of the slopes.

Table 24.4 Factor of Safety Requirements – Side Slopes

Failure Mode	Loading Scenario	Required Minimum FoS
Downstream	Static loading and steady state phreatic surface (peak shear strength)	1.3 to 1.5
Downstream	Pseudo-static loading with steady state phreatic surface	1.1 to 1.3

24.4.9 Water Management Design

Water management requires careful consideration for any TSF, due to the non-cohesive nature of tailings and its propensity to flow freely when over saturated. For TSFs, water management implies the removal of supernatant water from the TSF, preventing large quantities of rain water from reaching and being stored on the TSF and reducing the seepage through the downstream toe.

The Bisie TSF and DWD require the following water management systems:

- A decant system for removing supernatant water from the TSF;
- An emergency spillway for storm events exceeding the 1:100 year storm event;

- Sub-soil drainage system for reducing the phreatic surface through the impoundment wall;
- A storm water diversion trench & berm to the volume of reduce run-off reaching the TSF;
- A dirty water collection trench; and
- Return Water Sump (RWS) for the collection of water reporting from the subsoil drains and run-off water from the TSF side slopes.

24.4.9.1 Decant System

The TSF has been designed as a full impoundment valley dam, which provides certain advantages with regard to the storage of water on the TSF. The impoundment wall is constructed from competent material providing increased strength, thus increasing the stability of the facility, even in the event of a raised phreatic surface. This means that some water can be stored on the TSF, therefore allowing a floating barge system and pump to be utilised, as opposed to a conventional penstock decant system.

A penstock was considered due to its reliability however a barge was selected over the penstock for the following reasons:

- A penstock would be more expensive than a barge due to the expected difficulty in transporting concrete pipes to the mine and the need to concrete encase the pipeline beneath the impoundment wall;
- A penstock would be difficult to construct due to the undulating topography; and
- Due to the Process Plant only operating 4 days a week, there will not be a large volume of slurry water reporting to the TSF, thus using a penstock (which is required for TSFs requiring constant decant) will not be necessary.

A barge comprises a floating platform with a pump mounted on top. The water is pumped directly from the TSF to the Process Plant.

A barge requires a minimum of 1m of supernatant water in order to operate without pumping excessive amounts of fine tailings, which an impoundment TSF can accommodate.

There are certain risks usually involved with operating a barge that must be mitigated, such as:

- The pump relies on electricity to function, therefore during power failures the water cannot be decanted and could result in overtopping of the TSF, which could cause failure of the impoundment wall;
- The pump is design to operate at a specific pumping rate according to the volume of slurry water reporting to the TSF, if a large storm event occurs the pump may not be able to decant water quickly enough, resulting in overtopping;

- During high winds the barge could capsize and get stuck in the soft tailings. In which case a new pump will be required;
- Other mechanical issues causing pump shutdown; etc.

These issues can be mitigated by proper maintenance, backup generators, robust design and backup pumps, however this is not always possible and therefore an emergency spillway has also been provided in the design.

24.4.9.2 Emergency Spillway and Freeboard

An emergency spillway has been included in the design to provide a measure for storm events greater than the 1:100 year storm event near the end of the life of the facility or for other emergency situations such as power failures or pump breakdowns, for water to be discharged off the TSF to prevent overtopping.

Freeboard is defined as the height below the impoundment wall to the maximum water storage level (or flood buffer zone). The DRC regulations require a 1m freeboard, therefore the spillway must be 1m below the final impoundment wall level which will be above the flood buffer zone. The TSF impoundment wall will be completed after 2.25 years, when there will be a 10 m freeboard and reduce to a minimum of 1 m, as the level of the Spiral Tailings increases.

Figure 24.9: Definition of freeboard

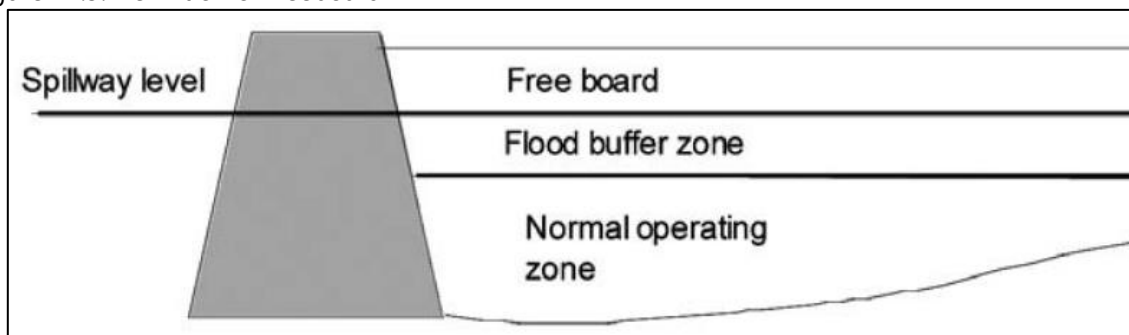

Source Epoch

The spillway has been design for a flow rate of 0.675 m³/s, based on a catchment area of 9 Ha. The spillway will be constructed from concrete and 10 m wide, by the operator, once the impoundment wall has been completed.

Figure 24.10: Catchment Area of TSF

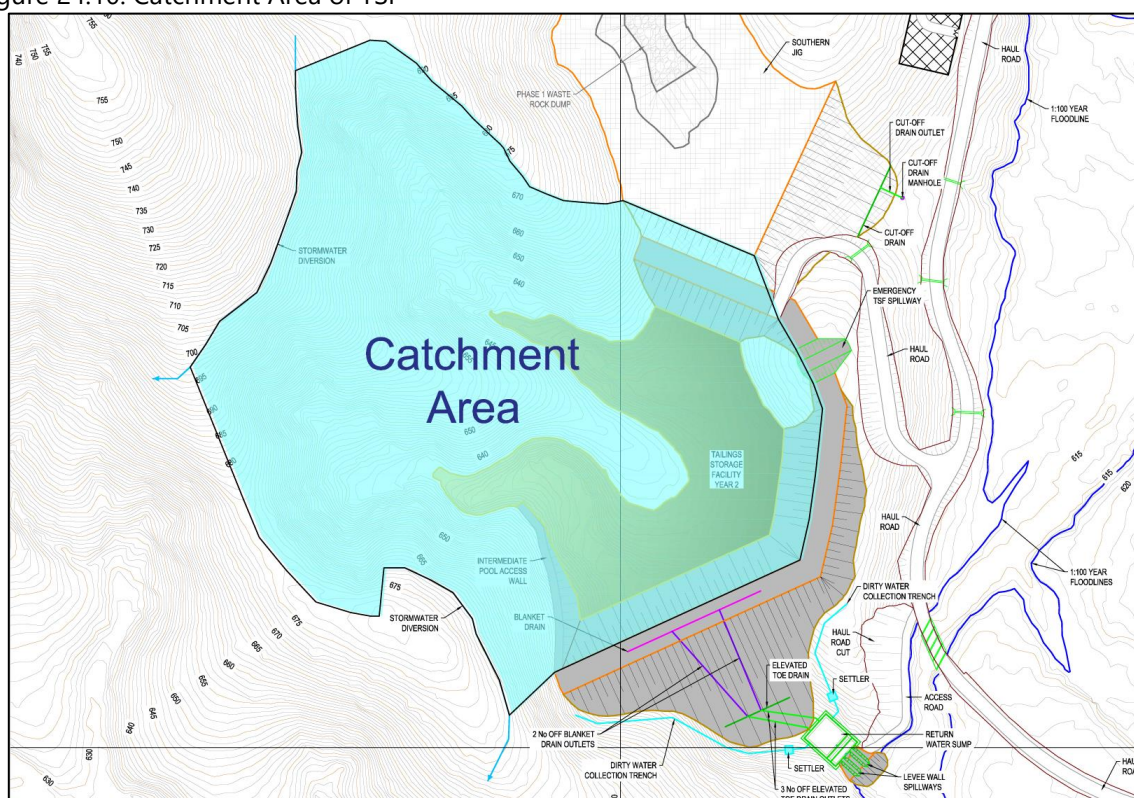

Source Epoch

24.4.9.3 Storm Water Diversion

The storm water catchment area of a valley impoundment TSF includes the area of the valley above the TSF footprint and would cause additional run-off to enter the TSF. Therefore a storm water diversion trench and berm is provided in order to reduce the size of the upstream catchment and the run-off onto the TSF. Run-off water is considered clean and should not be contaminated with process water where possible. Therefore run-off caught in the trench is diverted around the TSF where it can flow into the Bisie River downstream of the TSF.

Due to the steepness of the slopes and the difficulty involved in cutting into such steep slopes, it was chosen not to divert all the run-off and only focus on areas where the slopes are flatter. The result is that the catchment includes some of the valley above it, however the amount of run-off is greatly reduced and more manageable.

24.4.9.4 Subsoil Drainage System

A subsoil drainage system, comprised of slotted pipes and filter material must be provided in order to reduce the phreatic surface through the impoundment wall. This was designed to collect water and convey it to the RWS. Seepage and Slope Stability modelling has shown the effectiveness of a subsoil drainage system in improving the stability of the TSF.

24.4.9.5 Return Water Sump

The TSF subsoil drains collect and convey seepage water from the TSF to a Return Water Sump (RWS). Additionally the RWS will collect run-off water from the side slopes of the TSF. This water

is temporarily stored in the RWS and then pumped back onto the TSF, where it can be pumped, via the pumping barge, back to the Process Plant.

24.4.9.6 Dirty Water Collection Trench

Run-off from the TSF impoundment wall will be contaminated with silt from the Jig Tailings, this must be directed to the RWS where it will be pumped onto the TSF. A dirty water collection has been included in the design to convey the contaminated run-off to the RWS. Two silt traps/energy dissipators have been included to settle out the silts before entering the RWS, as well as reduce the kinetic energy of the water flow so as to prevent damage to the RWS.

24.4.10 Conclusions

The following conclusions were deduced from the studies documented in this report:

- The geochemical testing determined whether the residues would produce any form of contamination to surface or groundwater:
 - Jig and Spiral Tailings were found to leach negligible contaminant concentrations; and
 - The Waste Rock was found to produce a sulphate and acid leach which, according to DRC regulations require that the underlying soils have a permeability of less than 1×10^{-8} m/s. Geotechnical test work showed that this is the case.
- The placed densities of the mine residues were determined as:
 - Spiral Tailings: 1.5 m³/t;
 - Jig Tailings: 1.8 m³/t; and
 - Waste Rock: 1.9 m³/t.
- A suitable site was identified in the site selection study, which may accommodate the required tonnes of waste;
- A geotechnical investigation determined that the site is mainly underlain by a silty clay material and with low permeabilities. Most samples exhibited high strength in terms of the friction angles (greater than 25°);
- From the seepage and slope stability analysis for the RDF, it was found that:
 - Inclusion of subsoil drains in the impoundment wall of the TSF lowers the phreatic surface through the wall. The effect of the drains becomes more apparent the closer the pool is situated to the edge of the wall;
 - Removing clays below the impoundment wall improved the stability of the wall;
 - High factors of safety were found for the facility due to the high strength of the Jig Tailings.
- The RDF has been designed to store a total of 590 400 dry tonnes of Spiral Tailings, 2.184 million dry tonnes of Jigs Tailings and 748 000 dry tonnes of Waste Rock and comprise the following:

- A full impoundment valley TSF, with a footprint area of 6.3 Ha and a maximum height of 24 m from the lowest contour;
 - A Jig Tailings and Waste Rock facility (DWD) with a footprint area of 9.5 Ha and a maximum height of 30m from the lowest contour; and
 - A 740 m³ Return Water Sump.
- The water balance model indicated that high return water volumes can be expected, particularly in the wetter months once the whole TSF basin is utilised (due to the larger catchment area);

24.5 MINE CLOSURE

24.5.1 Decommissioning and Closure

At a conceptual level, decommissioning can be considered a reverse of the construction phase with the demolition and removal of the majority of infrastructure and activities very similar to those described with respect to the construction phase.

The closure phase occurs after the cessation of all decommissioning activities. Relevant closure activities are those related to the after care and maintenance of remaining structures.

24.5.2 Closure outcomes, objectives and targets

The planning stage for decommissioning and closure has commenced and in broad terms the main objective will be to remove as much infrastructure as possible and rehabilitate what remains to resemble the pre project land state as closely as possible. At this stage, the proposed post closure land use will be a combination of agriculture and wilderness. Closure objectives have been developed against the background of the project location in the rural parts of the North Kivu Province located at the end of a dead end road. The following objectives have been set:

- disturbed areas other than those comprising the subsided area and the mineralised waste facilities will be returned to as close to their original state as practicable;
- permanent visible features such as the mineralised waste facilities and related environmental bunds as well as safety bunds around the subsided area will be left in a form that blends with the surrounds;
- contamination beyond the mine site by wind, surface runoff or groundwater movement will be prevented through appropriate erosion resistant covers, containment bunds and drainage to the subsided area;
- linear infrastructure comprising roads, pipelines, power lines, conveyors and related components will be removed and the disturbed land rehabilitated to blend with the surrounding natural environment; and

- socio-economic impacts (including the loss of employment) will be minimised through careful planning and preparation for closure beginning three to five years before closure takes place.

The above principles and concepts will be refined as part of on-going detailed closure planning and costing during the life of mine.

The target closure outcomes for the mine and its associated infrastructure are assumed to be as follows:

- to achieve chemical and physical stability for an indefinite, extended time period over all disturbed landscapes and residual mining infrastructure;
- to protect surrounding surface, groundwater, soils and other natural resources from loss of utility value or environmental functioning;
- to limit the rate of emissions to the atmosphere of particulate matter and salts to the extent that degradation of the surrounding properties' land value and land capability does not occur;
- to achieve visual 'harmony' with the surrounding landscape, and
- to create a final land use that has economic, environmental and social benefits for future generations that outweigh the long term aftercare costs associated with the facility.

The target closure outcomes and goals are expressed in terms of several key performance areas. These are summarised in the Table below.

Key Performance Area	Key Performance Indicator	Standard Adopted / Target Value
TSF and WRD geochemistry	Levels of toxicity and AMD potential of the tailings and waste rock	Any runoff discharged into the environment should meet IFC effluent standards
Dust fallout rates	To achieve compliance with the IFC standards in terms of dust emissions considering nuisance dust, ingestible and inhalable size fractions (PM10's), toxicity or radiological dose measured anywhere around the mineralised waste facilities where 3rd party land use does or might occur in future.	IFC Dust and PM 10 standards IFC Environmental, Health and Safety Guidelines Mining – radiological exposure – occupational health
The quality of runoff from the TSF and WRD facilities	Post decommissioning, the closure solution requires that runoff and seepage is environmentally neutral, with concentrations of contaminants that do not exceed average environmental backgrounds in order to avoid detrimental impacts	IFC Environmental, Health and Safety Guidelines Mining
The quality of groundwater in the vicinity of the plant, WRD and TSF	The magnitude and extent of contaminant plumes should indicate a temporal trend of improvement with time. Beyond the limits of an agreed buffer zone, the concentration of contaminants in the groundwater should not pose a further risk to existing or future potential groundwater resource users in terms of toxicological or radiological limits.	WHO drinking water standards will be met on the perimeter of the waste rock dumps, TSF and plant with respect to TDS (<1000mg/l), SO4<250mg/l, Cu (<1.0 mg/l, Co<0.5mg/l, Cl<250mg/l).
Sediment loads	Sediment loads should be at levels that do not impact on aquatic and terrestrial ecosystems and downstream users	IFC guideline specifies TSS <50mg/l which would apply to the point of discharge of surface water to the natural streams
Long term aftercares costs	To design the TSF as close to a self-sustaining structure as practically possible	No standard applicable
Erosion	The soil formation rate should be greater than or equal to the rate of soil erosion	Since soil formation is a long-term process, it is necessary to assume that the erosion rate on sustainable natural slopes is less than or equal to the accretion rate on these slopes.

Relinquishment of ownership

The TSF and WRD complex should be capable of being responsibly relinquished without the expectation that the state or third party has sophisticated or specialist knowledge or understanding of the risks and hazards associated with the dam during the aftercare phase.

No standard applicable

24.5.3 Decommissioning and Rehabilitation Activities

At a conceptual level this is a reverse of the construction phase. The conceptual decommissioning plan is as follows:

- surface infrastructure will be demolished and removed, with the exception of the mineralised waste facilities that will remain in perpetuity. The subsided area will also remain in perpetuity;
- areas where infrastructure has been removed will be levelled and restored in terms of soils horizons, vegetation and drainage;
- subsided area decommissioning;
- an exclusion bund will be constructed around the subsided area;
- seepage water and all other contaminated water that can drain naturally to the subsided area will be allowed to evaporate; and
- side slopes will be assessed and stabilised for long-term stability performance.

Additional activities associated with aspects of the mine that require decommissioning and rehabilitation include:

24.5.3.1 *Underground Mine*

The sealing of shafts, adits and all other man accessible excavations to the underground workings. The seal to the underground workings will be constructed from materials which will require sophisticated demolition equipment to breakthrough.

Of significant importance is to limit the opportunity for inflow of surface water into the subsided mine area. To control this, bunds will be built on the upslope portion of the subsided area to direct surface run-off water away from the subsided area.

24.5.3.2 *Tailings Storage and Waste Rock Dump Facilities*

The facilities (WRD and TSF) will be shaped to a landform that blends with the surroundings as part of concurrent rehabilitation and in accordance with visual impact mitigation measures;

The top of the TSF facility will be allowed to dry out for approximately 2 years before the final cap is put in place and sealed for rehabilitated. During this time, the dust pollution will be controlled through vegetation growth;

Runoff and eroded material from the dump surface will be captured behind a perimeter bund and allowed to evaporate. Along the eastern perimeter, the runoff and eroded material will be directed to the pollution control trench;

Seepage will be directed to a cut off drain;

Aftercare and maintenance will be designed and implemented for the post closure phase; and

Surface and groundwater quality will be monitored regularly for a period to be agreed upon with the relevant authorities.

24.5.3.3 Processing Plant

All brick and concrete buildings associated with the processing plant will be demolished and the rubble buried either on site to a minimum depth of 1.0m or used as cover material for the TSF cover construction.

The processing plant, primary crusher and conveyors will all be dismantled, and salvageable elements will be de-contaminated and sold. Conveyor belts and concrete footings as well as non-salvageable steel will be disposed of within the tailings facility.

The residual excavations after removal of the processing plant and primary crusher will be backfilled and levelled with selected non-AMD generating material from the underground mining operations and covered with 500 mm of stockpiled topsoil. The plant area will be landscaped and shaped to ensure that it is contiguous with, and blends into, the surrounds. The soil and vegetation function of the land will be restored.

24.5.3.4 Other buildings and infrastructure

All brick and concrete buildings associated with the infrastructure will be demolished and the rubble buried either on site to a minimum depth of 1.0m or used as cover material for the TSF cover construction. This includes:

- roads, pipelines and other linear infrastructure;
- housing;
- medical facility;
- laboratory;
- workshops;
- waste water treatment;
- explosive magazine;
- admin buildings and offices;
- security buildings;
- stores;
- salvage yard and laydown areas;
- parking area; and
- fencing.

24.5.4 Calculation of Future Financial Closure Liability

The calculation of the financial closure liability associated with ABM's underground tin mining operation at Bisie has been undertaken by following best international practice methodology (Australia, USA, Canada and South Africa) as detailed in the Guideline Document for the Evaluation of

the Quantum of Closure - Related Financial Provision Provided by a Mine as published by the South African Department of Mineral Resources, dated January 2005.

24.5.4.1 Input to the Financial Closure Liability Calculation

The best practice procedure for calculating financial closure liability is summarised as follows:

- Step 1: Determine the primary mineral and saleable mineral by-products.
- Step 2: Determine the risk class of the mine.
- Step 3: Determine the area sensitivity in which the mine is located.
- Step 4.1: Determine the level of information available for calculating the financial liability.
- Step 4.2: Determine the closure components associated with the mine.
- Step 4.3: Determine the unit rates for the associated closure components.
- Step 4.4: Determine and apply various weighting factors (site specific).
- Step 4.5: Identify the areas of disturbance.
- Step 4.6: Identify any specialist studies required.
- Step 4.7: Calculate the closure liability using the guideline template provided.

24.5.4.2 Calculated Closure Liability

The financial closure liability associated with the Bisie Project is US\$ 1,876,198 for the future areas of disturbance (at end of Life of Mine, LOM).

Table 24.5 Closure Liability Calculation

Description	Unit	Rate (US\$)	Qty	W1	W2	Cost (US\$)
Dismantling of processing plant & related structures	t	300	1,194	1.2	1.2	515,808
Demolition of steel buildings and structures	t	300	65	1.2	1.2	28,080
Demolition of reinforced concrete structures	m ²	48.5	2,440	1.2	1.2	170,410
Demolition of housing &/or administration facilities	m ²	15.0	680	1.2	1.2	14,688
Sealing of shafts, adits & inclines	m ³	1,200	100	1.2	1.2	172,800
Rehabilitation of overburden & spoils	m ²	2.5	10,000	1.2	1.2	36,000

Rehabilitation of processing waste deposits	m ²	2.5	157,670	1.2	1.2	567,612
Rehabilitation of subsided areas	m ²	2.5	30,000	1.2	1.2	108,000
General surface rehabilitation	m ²	2.5	40,000	1.2	1.2	144,000
Fencing	m	1.5	7,000	1.2	1.2	15,120
2 to 3 years of maintenance & aftercare	yr.	24,000	3	1.2	1.2	103,680
Total						1,876,198

24.6 OPERATIONAL READINESS

24.6.1 Management Philosophy

Alphamin intends to manage and operate the Bisie operation in a manner that is consistent with the Alphamin Policies and Procedures. These Policies include:

- Risk Management Framework.
- Approvals Framework.
- Human Rights and Code of Ethics policy.
- Information technology and communications policy.
- Travel policy.
- Mineral Resources and Mineral Reserves Reporting policy.
- SHEC policy.
- Recruitment and selection policy.
- Leave policy.
- Acting Policy.
- Fly In Fly Out Policy.
- Poor work performance policy.
- Sick leave policy.
- HR Information system policy.
- Employee relations policy.
- Medical aid policy.

- Accounting and audit policy.
- Reward and recognition policy.
- Company vehicle policy.
- Public relations and interaction with stakeholders policy.
- Occupational health and safety policy.
- Environmental policy.
- Communities policy;

Alphamin is committed to the employment and training of DRC nationals, yet it recognises the need for expatriate employees in certain key positions for the medium term (3 to 5 years).

24.6.2 Historical Labour Force

Alphamin inherited a workforce of approximately 60 employees when it purchased the MPC assets from the previous owners. The labour force inherited will be re-employed in the Bisie operations provided they have the necessary skills as required.

24.6.3 Employment Action Plan

As part of the feasibility study for the Bisie Project, Alphamin has undertaken a Social Impact Assessment (SIA). The findings of the SIA recommend the establishment of an Employment Action Plan (EAP) to manage the recruitment process of new employees.

The goals of the Employment Action Plan are to maximise local participation in the direct and indirect employment opportunities provided by the Project during construction, operation, closure, and post-closure. In doing so, Alphamin will optimise the benefits of the Project for the local economy and reduce in-migration and the associated impacts on communities in the Project area. The desired outcomes of the EAP are:

- Involve key stakeholders in defining and implementing the Plan;
- Identify the number of qualified local workers;
- Maximise direct employment of local and national workers;
- Facilitate upward mobility of local and national staff within Alphamin;
- Identify the number of qualified local and national contractors/vendors;
- Maximise procurement from qualified local and national contractors/vendors;
- Maximise indirect employment of local and national workers.

Alphamin will appoint where appropriate independent consultant to develop and implement the EAP.

24.6.4 Operating Schedules

The operating schedules for the various functional areas of the operation will be adjusted to ensure compliance with the DRC labour laws. The 2 key elements of the DRC labour laws that impact on the operating schedule are:

- Employees to work a 45 hour work week; and
- Employers must allow an employee 48 hours rest between work weeks.

24.6.5 Mining Function Working Schedule

The mining department will operate over 2 shifts, the day shift and the afternoon shift. The duration of each shift will be 9 hours, 8 of which will be spent working. Workers will be required to break for 1 hour during the shift to take in a meal and reduce the risk of fatigue associated with operating heavy equipment continuously over an extended period. The mining day shift will run from 06h00 to 15h00 and the afternoon shift from 17h00 to 02h00, the break allowing for blasting fumes to be removed from the mine before the new shift enters the workings.

The shift roster will rotate forwards on a weekly basis to ensure the requirements for a 48 hour break are respected. The crew working night shift will finish their week at 02h00 on a Saturday morning and start their day shift roster at 06h00 on Monday. The crew working day shift will finish their week at 15h00 on Saturday and start their afternoon shift roster at 17h00 on Monday.

The workers will be required to work an eleven shift fortnight, resulting in 88 hours being worked per 2-week cycle. The shift arrangements for the mining staff are depicted below.

Figure 24.11 Mining Shift Roster Arrangements

Mo		Tue		Wed		Thur		Fri		Sa		Sun		Mo		Tue		Wed		Thur		Fri		Sat		Sun			
D/S	A/S	D/S	A/S	D/S	A/S	D/S	A/S	D/S	A/S	D/S	A/S	D/S	A/S	D/S	A/S	D/S	A/S	D/S	A/S	D/S	A/S	D/S	A/S	D/S	A/S	D/S	A/S	D/S	A/S
Shift 1										Rest		Rest		Rest										Rest		Rest		Rest	
Shift 2																													

24.6.6 Process Plant Function Working Schedule

The process plant will operate for 7 days per week, 24 hours per operating day. This will require manning for 3 shifts, with one team on day shift, one on night shift and one recovering. Process plant workers will operate in 6-day cycles consisting of 2-days day shift, 2-days night shift and 2-days rest.

The plant engineering labour will be required to work the same shift system as the process plant personnel.

24.6.7 Administration, Mineral Resource Management and Services Departments

The support service departments will operate 5 days per week, working 9 hours per day.

24.6.8 Staff Requirements

The summary staffing requirements are presented below.

Table 24.6 Proposed Staffing Levels

Department	At work requirement	Leave/Absentee	Total
Executive Group	6	0	6
Process plant	69	9	78
Engineering	57	9	66
MRM	15	2	17
Services	86	13	99
Finance	32	5	37
Strategic growth	67	10	77
DRC Country management	12	2	14
Human Resources	19	3	22
TOTAL	363	53	416

24.7 RISK

24.7.1 Risk Review Summary

In order to increase the likelihood that the project reaches its objectives, project risk and risk workshops were held. Risk assessment was performed by combining the threats identified through project risk reviews, safety, health and environment (SHE) reviews and hazard & operability (HAZOP1 & 2) reviews.

The most significant risks (threats) to the project objectives are reported in a top 20 Risk Register which will be discussed later on. The top 3 risks are however as follows:

- Logistics - access from an East African port to the project site;
- Security – threat of armed groups and artisanal miners;
- Geotechnical conditions – impact on mine development rates and build-up to full production capacity.

24.7.2 Risk Reporting Template

The risk reporting template includes the following aspects:

- Risk category/cluster
- Description of the risk
- Discussion on the context of the risk
- Discussion on the business implications of the risk
- Review of the current controls
- Evaluation of the efficiency of the controls

Evaluation of impact and likelihood

- Overall rating
- Risk Mitigation measures
- Action plan and risk mitigation strategies with specific responsibility.

The risk matrix used is depicted below:

Table 24.7: Risk Matrix

RISK MATRIX	Hazard Effect Consequence <i>(Where an event has more than one 'Loss Type', chose the 'Consequence' with the highest rating)</i>				
	1. INSIGNIFICANT	2. MINOR	3. MODERATE	4. MAJOR	5. CATASTROPHIC
Loss Type <i>(Additional 'Loss Types' may exist for an event, identify and rate accordingly)</i>					
(S/H) Harm to People (Safety/Health)	<i>First aid case/Exposure to minor health risk</i>	<i>Medical Treatment cast/ Exposure to major health</i>	<i>Lost time injury/ Reversible impact on health</i>	<i>Single fatality or loss of quality of life/ Irreversible impact on health</i>	<i>Multiple fatalities/impact on health ultimately fatal</i>
(EI) Environmental Impact <i>(Includes spatial scale (SS), duration (D) and severity (S)*)</i>	<i>Minimal environmental harm SS, D and S are all L Level 1 incident</i>	<i>Material environmental 1 of SS, D and S is M, other 2 are L Level 2 incident</i>	<i>Serious environmental harm – SS, D and S combination not defined in other categories Level 3 incident</i>	<i>Major environmental harm – 2 of SS, D and S are H and 1 is L, or 3 of SS, D and S are M Level 4 incident</i>	<i>Extreme environmental harm – SS, D and S are all H, or 2 of SS, D and S are high and one is M Level 5 incident</i>
(BI/MD) Business Interruption/Material Damage and Other Consequential Losses	<i>No disruption to operation/US\$20k to US\$100k</i>	<i>Brief disruption to operation /US\$100k to US\$1.0M</i>	<i>Partial shutdown/ US\$1.0M to US\$10.0M</i>	<i>Partial loss of operation/ US\$10.0M to US\$75.0M</i>	<i>Substantial or total loss of operation/>US\$75.0M</i>
(L&R) Legal & Regulatory	<i>Low level legal issue</i>	<i>Minor legal issue; noncompliance and breaches of the law</i>	<i>Serious breach of law; investigation/report to authority, prosecution and/or moderate penalty possible</i>	<i>Major breach of the law; considerable prosecution and penalties</i>	<i>Very considerable penalties and prosecutions. Multiple law suits and jail terms</i>
(R/S/C) Impact on Reputation/Social/Community	<i>Slight impact – public awareness may exist but no public concern</i>	<i>Limited impact - local public concern</i>	<i>Considerable impact – regional public concern</i>	<i>National impact – national public concern</i>	<i>International impact – international public attention</i>

Bisie Tin Project
NI43-101

Likelihood	Examples (consider near hits as well as actual events)	RISK RATING				
		5 (Almost Certain)	The unwanted event has occurred frequently; Occurs in order of one or more times per year and is likely to re-occur within 1 year	11 (M)	16 (H)	20 (H)
4 (Likely)	The unwanted event has occurred infrequently; occurs in order of less than once per year and is likely to re-occur within 5 years	7 (M)	12 (M)	17 (H)	21 (EX)	24 (EX)
3 (Possible)	The unwanted event has happened in the business at some time, or could happened within 10 years	4 (L)	8 (M)	13 (H)	18 (H)	22 (EX)
2 (Unlikely)	The unwanted event has happened in the business at some time, or could happened within 20 years	2 (L)	5 (L)	9 (M)	14 (H)	19 (H)
1 (Rare)	The unwanted event has never been known to occur in the business; or it is highly unlikely it will occur within 20 years	1 (L)	3 (L)	6 (M)	10 (M)	15 (H)

RISK RATING	RISK LEVEL	GUIDELINES FOR RISK MATRIX
21 to 25	(Ex) = Extreme	<i>Eliminate, avoid, implement specific actions, plans/procedures to manage and monitor</i>
13 to 20	(H) = High	<i>Proactively manage</i>
6 to 12	(M) = Medium	<i>Actively manage</i>
1 to 5	(L) = Low	<i>Monitor and manage as appropriate</i>
*ENVIRONMENTAL RISK RATING	DEFINITION	
SEVERITY		
<i>H</i>	<i>Substantial deterioration (death, illness or injury). Violation of standards (legal and other), vigorous community action</i>	
<i>M</i>	<i>Moderate / measurable deterioration (discomfort). Standards will occasionally be violated. Widespread complaints.</i>	
<i>L</i>	<i>Minor deterioration (nuisance). Change is not measurable, or will remain in the current range. Standards not violated. Sporadic complaints.</i>	
SPATIAL SCALE		
<i>H</i>	<i>Widespread – far beyond the site boundary. Regional / national. International consequence</i>	
<i>M</i>	<i>Fairly widespread – beyond the site boundary. Local.</i>	
<i>L</i>	<i>Localised – within the boundary of the site</i>	
DURATION		
<i>H</i>	<i>Long-term. Permanent. Beyond closure.</i>	
<i>M</i>	<i>Medium term. Reversible over time. Life of the project.</i>	
<i>L</i>	<i>Short-term. Quickly reversible. Less than the project life.</i>	

The risk matrix takes into account the following aspects:

- Hazard effect consequence
- Loss type
- Likelihood
- Environmental severity, spatial scale and duration

The risk matrix also gives a guideline for risk tolerance in that the risk rating is defined in broad categories linked to a risk level which in turn is linked to a guideline on the required action stemming from the risk identification process.

24.7.3 Control Effectiveness

The effectiveness on the controls in place to reduce the risks is determined by applying the following standard:

CONTROL EFFECTIVENESS	%	DEFINITION OF CONTROL EFFECTIVENESS RATING
<i>Very good</i>	90	<i>Effective management of risk and control</i>
<i>Good</i>	80	<i>Major part of exposure effectively controlled.</i>
<i>Satisfactory</i>	65	<i>Improvement to the control required</i>
<i>Weak</i>	45	<i>Some risk controlled but exposure still possible</i>
<i>Unsatisfactory</i>	25	<i>Control measures are insufficient</i>

24.7.4 Risk Register

The most significant business risks carried forward from the review sessions are summarised below:

Table 24.8: Bisie Business Risk Register

Risk Category	Risk	Context	Potential Impact (Business Implications)	Existing Controls	Control Effectiveness	Desired control Effectiveness	Risk Owner	Risk Mitigation Strategies	Inherent Risk Ranking	Residual Risk Ranking
Business Risk - Commercial	Uncertainties around the development of a mining operation in a remote, post conflict location	Timing and costs	Failure to build on the forecast schedule	DFS to include detailed project execution plan	50%	95%	Trevor Faber	Robust contractual penalties and incentives for EPCM contractor	21	20
		Non availability of skilled labour in the area	Reduced ability to execute according to quality control plan	Recruit in labour from external areas	40%	80%	Trevor Faber	Establish training centres for development of key skills	17	17
		Limited road infrastructure for project construction and operational phases	Delays and additional project costs. Increased off-mine costs associated with transport of concentrate	Helicopter, diesel generators and bush track to site	40%	80%	Trevor Faber	Establish permanent road from Bisie to Logu, rehabilitate national roads, and install industrial scale electrical power generators	19	19
		Lack of suppliers of mining consumables and support services	High operating costs	Community development initiatives	25%	80%	Richard Robinson	Assist local entrepreneurs with development training	20	20

Bisie Tin Project

NI43-101



Business Risk - Mineral Resources and Reserves	Inaccurate Mineral Resource and Reserve estimates	The value driver for the Bisie project is the high grade feed to the process plant. Any reduction in the feed grade (dilution or inaccurate model) will reduce profitability	Failure to achieve project returns	Exploration protocols with third party sign off on QA/QC. Geotechnical logging of boreholes. Independent mine design consultants. Peer review.	75%	90%	Trevor Faber	Ongoing drilling programmes with robust QA/QC program. Structural mapping of the project area, and modelling of geology and structures.	23	19
		The controls on mineralisation are not well understood at Bisie.	Overestimation of grade or tonnage	Newer drilling programs have been planned on 25m borehole spacing	85%	90%	Trevor Faber	Ongoing drilling with structural interpretation and modelling of faults, shear zones and lithology	21	17
		Some of the Mineral Resources at Mpama North are classified as Inferred Mineral Resources which by their definition are high risk estimates that could change significantly with additional data	Company reputation could be put at risk if downgrade in Mineral Resources is announced	3rd party sign-off on Mineral Resources	85%	90%	Trevor Faber	Independent peer review	21	15
Business Risk - Political	Operating in post conflict environment	Subject to greater legal, regulatory economic and political influence	Change in regulations affecting tenure and earnings	Relationships with embassies of South Africa and USA	65%	75%	Richard Robinson	Increase dialog with Partners and State officials	18	15

Bisie Tin Project

NI43-101



		Alphamin is dependent on favourable socio-economic and political conditions prevailing in North Kivu	Shareholder uncertainty on managements's ability to operate in a fragile environment subject to fluctuations in political leadership	Regular meetings with shareholders	65%	75%	Boris Kamstra	Develop communication strategy and communicate social programs to stakeholders	21	19
	DRC laws susceptible to change, revision or cancellation	Political influence on tenure and the running of mining operations	Loss of mining title	Liaison with Provincial and National Governments	65%	75%	Richard Robinson	Regular liaison with Provincial and National Governments	22	20
		Changes to the mining codes, tax laws, safety, health and environmental legislation	Opportunity cost of new projects	Contact with other mining companies	65%	75%	Richard Robinson	Join DRC chamber of mines, maintain credibility and apply international best practice	17	15
		Elections and changes in government	Loss of mining title	Participation in business forums. Relationships with embassies of South Africa and USA	55%	75%	Richard Robinson	Monitor development of political alliances and communicate frequently with State officials	22	18
	Withdrawal or termination of operating and exploration licenses	Exploration, mining and processing requires licences from DRC authorities	Company could lose its operating license and exploration projects	Complying with the legal, safety, health and environmental regulations	65%	80%	Richard Robinson	Review regulations and statutes for compliance	22	20
		DRC operations are dependent upon import and export licences	Reinstatement of licenses takes time, effort and money	Maintaining cordial relationships with business partners	50%	80%	Richard Robinson	Continued interaction with Provincial and National Government	18	15

Bisie Tin Project

NI43-101

		Potential prohibition on export of concentrate	Inability to export concentrate has major financial implications	Open dialog with political decision makers	65%	80%	Richard Robinson	Investigate feasibility of establishing tin smelter in country	22	20
	Regional instability and political developments in neighbouring countries	Political and social unrest in the DRC or Burundu could impact on North Kivu	Business interruptions	Securing of mining sites	80%	80%	Trevor Faber	Install perimeter fencing	17	15
			Damage to equipment	Visible security presence	80%	80%	Trevor Faber	Maintain PNC and mine security presence	17	14
			Damage to structures and business premises	Cordial relationships with local communities	75%	80%	Trevor Faber	Regular patrols	17	15
			Social uprising and destruction of exploration camp and bore core	Stakeholder engagement programmes	55%	80%	Richard Robinson	Voluntary Principles on Security and Human Rights (VPSHR) programme	19	17
Business Risk - Infrastructure			Inability to efficiently import consumables required for production and the export of tin concentrate to market	Access to Bisie from the existing N3 road is through 31km of dense jungle and mountainous terrain	Project delays and cost overruns in establishing the access road	Project management practices	60%	90%	Trevor Faber	Construct access road from Logu to Bisie in phased approach
		The main access route to Walikale from Goma is impassable. All supplies will need to be routed via Kenya and Uganda	Increased operating costs due to "third country rule" applied to fuel imports or tin exports	Purchase goods in-country	40%	90%	Eoin O'Driscoll	Appoint freight clearing agents to manage third party logistic providers	22	20
		Congested port facilities at Mombasa and Dar es Salam	Increased working capital requirements due to longer supply chain (creditors) and extended debtors receivable	Nil	60%	80%	Trevor Faber	Complete logistics study as part of DFS	22	20

Mitigation strategies (preventive in many of the Top 20 cases) have been identified to address threats that allowed reducing their Residual Risk rating. For some threats, the cost estimate has been revised or the scheduled has been adjusted to minimize the likelihood of unwanted events or to reduce their impact.

24.7.5 HAZOP Assessments

The risk management process included completion of HAZOP 1, 2 and 3.

24.7.6 Risk Management Plan

A Risk Management Plan has been developed by Alphamin and responsibilities were allocated accordingly.

24.7.7 Hazardous Area Classification

The hazardous area classification for the existing plant has been reviewed. There are no changes envisaged taking the project to execution phase.

25 INTERPRETATION AND CONCLUSIONS

The Qualified Persons, as Authors of their corresponding Sections of this Report, have reviewed the data for the Project and are of the opinion that:

- Mining tenure held by ABM SA is in place and must take appropriate steps to ensure renewal of the leases as effected timeously.
- At this time, all permits required for ongoing exploration and the pioneering phase of the project are in force. Permits required for full construction and operation is in place according to: Official Document of the Democratic Republic of Congo LAW No. 007/2002 of JULY 11, 2002
- Metallurgical testwork is appropriate and adequate to support Mineral Reserve estimation, project feasibility, and economic analysis.
- Estimates of Mineral Reserves conform to industry-standard practices. Mine plans, dilution and economic parameters applied to resource estimates have been prepared to industry standard practices.
- Mineral reserves support a 360-390 thousand tonne per year operation with a mine life of 12 years.
- The process plant design makes use of proven processing equipment.
- Process plant design has been adequately defined for accurate cost estimating purposes.
- Mine infrastructure has been adequately designed and estimated using industry standard practices.
- A host country compliant Environmental, Social and Health Impact Assessment (ESHIA) was completed.
- A host country Environmental & Social Management Programme (ESMP) was completed.
- Mine closure plans have been developed.
- The project is sufficiently robust for proceeding to project financing to support the development program.

25.1 CAUTIONS REGARDING FORWARD LOOKING INFORMATION

This report contains forward-looking information regarding projected mine production rates and forecasts of resulting cash flows as part of the feasibility study. These estimates are based on assumptions regarding input costs that include but are not limited to labour wages, steel, diesel fuel, operational contracts, and mining and processing equipment, that may be significantly different if a mine were to be built and operated. Other factors such as: to obtain major equipment and/or skilled

labour on a timely basis; to achieve the assumed mine production rates at the stated tin rates, may cause actual results to differ from those presented here.

Words such as "anticipate", "believe", "plan", "expect", "estimate", "intend", "budget", "scheduled", "forecast", "project" and similar expressions are often (but not necessarily always) used to identify forward-looking information.

25.2 CONCLUSIONS

- The Project is economically viable based on the LoM schedule, forecast operating costs and assumed tin price.
- The Project is technically credible, utilising designs and practices that are proven in the tin mining industry.
- The Mineral Resource is classified into Measured, Indicated and Inferred categories.
- The Mineral Reserves are classified into Proven and Probable categories
- The project is environmentally sound, utilising simple and proven management plans.
- The project provides socioeconomic benefits and has established hiring, training, employment and business procurement objectives

Risks for the project have been identified and include the following

- The logistical challenges of providing access to the project from an East African port
- Security, including local artisanal miners and rebel groups that may cause conflict.
- Ground conditions and mining, specifically rock competency in the weathered zone and the role it may play in causing project execution delays.

26 RECOMMENDATIONS

The Bisie Project provides robust economic returns based on the conclusions of this report and it is recommended that the project be funded for development.

27 DATE AND SIGNATURE PAGE

This report titled "Alphamin Resources Corporation, Bisie Tin Project, North Kivu Province, Democratic Republic of the Congo – NI 43-101 Technical Report – 23 March 2017 Front End Engineering Design and Control Budget Estimate Report" with an effective date of 06 February 2017, dated 23 March 2017, was prepared and signed by the following authors:

Dated at Johannesburg, South Africa
23 March 2017

"signed and stamped"
Jeremy Charles Witley
Pr.Sci.Nat., BSc (Hons), MSc (Eng.), FGSSA
Principal Resource Consultant
The MSA Group (Pty) Ltd

and

Dated at Johannesburg, South Africa
23 March 2017

"signed and stamped"
Mark Creswell
MSc, FSAIMM, MIMMM, Pr Eng
Consulting Process Engineer

and

DRA Projects (Pty) Ltd.

Dated at Johannesburg, South Africa
23 March 2017
Engineering,

"signed and stamped"
John Anthony Cox
BSC. Eng.(Mining)Honours Degree, Mining
F.S.A.I.M.M, ECSA Pr Eng
Principal Engineer
Royal HaskoningDHV

**APPENDIX 1:
Glossary of Technical Terms**

Glossary of Technical Terms

<i>artisanal miner</i>	A small-scale or subsistence miner, generally working independently, mining or panning for minerals.
<i>assay</i>	A qualitative or quantitative analysis of a metal or ore to determine its components; a substance to be so analysed; the result of such an analysis.
<i>basement</i>	The igneous and metamorphic crust of the earth, underlying sedimentary deposits.
<i>blank sample</i>	A quality assurance sample lacking the parameters of interest. A blank sample result is used to detect contamination during sample handling, preparation, and/or analysis. Examples of a blank sample include deionized water or a blank certified standard reference material.
<i>botryoidal</i>	A globular external form resembling a bunch of grapes.
<i>brecciated</i>	Condition applied to an intensely fractured body of rock.
<i>bulk modal analysis</i>	Performed by QEMSCAN using a linear intercept method – it is used to provide statistically abundant data for mineral identification, speciation, distribution and quantification.
<i>Carrière</i>	From French - Mine or quarry.
<i>cassiterite</i>	A red-brown or black tin oxide mineral (SnO ₂)
<i>Chantier(s)</i>	Illegal artisanal mining sites
<i>chloritisation</i>	The replacement by alteration into or introduction of chlorite
<i>CNDP</i>	<i>Congrès National pour la Défense du Peuple.</i>
<i>coltan</i>	Short for columbite-tantalite; a dull black metallic ore from which the elements niobium and tantalum are extracted.
<i>conglomerate</i>	A rock type composed predominantly of rounded pebbles, cobbles or boulders deposited by the action of water.
<i>craton</i>	Large, and usually ancient, stable mass of the earth's crust comprised of various crustal blocks amalgamated by tectonic processes. A cratonic nucleus is an older, core region embedded within a larger craton.
<i>CRM</i>	Certified reference material - a standard material that has been certified for certain elements with a given range of uncertainty.
<i>CV</i>	Coefficient of Variation - A statistical measure of the dispersion of data points in a data series around the mean.
<i>diamond drilling</i>	Method of obtaining cylindrical core of rock by drilling with a diamond set or diamond impregnated bit.
<i>dolomite</i>	A mineral composed of calcium and magnesium carbonate; a rock predominantly comprised of this mineral is also referred to as dolomite or dolostone.

<i>DMS</i>	Dense Media Separation. The use of fluids of different, known, densities to separate minerals.
<i>duplicate sampling</i>	Sampling program initiated to validate previous sampling results.
<i>FARDC</i>	<i>Forces Armées de la République Démocratique du Congo</i>
<i>fault</i>	A fracture or fracture zone, along which displacement of opposing sides has occurred.
<i>flotation</i>	A process for separating minerals from gangue by taking advantage of differences in their hydrophobicity.
<i>fold</i>	A planar sequence of rocks or a feature bent about an axis.
<i>Force Majeure</i>	A French term literally translated as "greater force", this clause is included in contracts to remove liability for natural and unavoidable catastrophes that interrupt the expected course of events and restrict participants from fulfilling obligations.
<i>gneiss</i>	A coarse-grained, banded, high grade metamorphic rock.
<i>gossan</i>	An iron-containing secondary deposit, largely consisting of oxides and typically yellowish or reddish, occurring above a deposit of a metallic mineral concentration.
<i>granite</i>	A leucocratic medium- to coarse-grained plutonic igneous rock composed principally of quartz and feldspar, with biotite and/or hornblende as the most common mafic minerals. Quartz forms between 20 % and 60 % of the felsic components and alkali feldspar forms 35 % to 90 % of the total feldspar.
<i>imaging</i>	Computer processing of data to enhance particular features.
<i>jig</i>	A machine which separates minerals of different densities using the settling characteristics in a pulsated fluid bed.
<i>Kriging</i>	Mathematical method used to predict the value of a given point by using a model of the spatial characteristics of the data.
<i>Landsat imagery</i>	Photographs of the earth's surface, collected by satellite, and taken at different wave-lengths of light, processed to enhance particular features.
<i>lithology</i>	A description of a rocks' physical characteristics visible at outcrop, in hand or core samples or with low magnification microscopy, such as colour, texture, grain size, or composition.
<i>mineralization</i>	A natural concentration of a mineral of interest.
<i>Mesoproterozoic</i>	Middle Proterozoic era of geological time, 1,600 to 1,000 million years ago.
<i>metamorphism</i>	Alteration of rock and changes in mineral composition, most generally due to increase in pressure and/or temperature.
<i>metasediments</i>	A sediment or sedimentary rock that appears to have been altered by metamorphism.
<i>Neoproterozoic</i>	Late Proterozoic era of geological time, 1,000 to 545 million years ago.

<i>Niton</i>	A Thermo Scientific portable XRF analyser.
<i>orogeny</i>	A deformation and/or magmatic event in the earth's crust, usually caused by collision between tectonic plates.
<i>Paleoproterozoic</i>	Lower / Early Proterozoic era of geological time, 2,500 to 1,600 million years ago.
<i>Proterozoic</i>	An era of geological time spanning the period from 2,500 to 545 million years before present.
<i>QEMSCAN</i>	Quantitative Evaluation of Materials by Scanning Electron Microscopy, a system that differs from image analysis systems in that it is configured to measure mineralogical variability based on chemistry at the micrometre-scale.
<i>REE</i>	A rare earth element or rare earth metal is one of a set of seventeen chemical elements in the periodic table, specifically the fifteen lanthanides plus scandium and yttrium.
<i>satellite positioning system (global positioning system GPS)</i>	An instrument used to locate or navigate, which relies on three or more satellites of known position to identify the operators location.
<i>scattergram</i>	A useful summary of a set of bivariate data (two variables), usually drawn before working out a linear correlation coefficient or fitting a regression line. It gives a good visual picture of the relationship between the two variables, and aids the interpretation of the correlation coefficient or regression model.
<i>schist</i>	A crystalline metamorphic rock having a foliated or parallel structure due to the recrystallisation of the constituent minerals.
<i>Screening</i>	The physical separation of material into size classes
<i>Semi-variogram</i>	Measure of spatial variability
<i>smectite</i>	A clay mineral (e.g. bentonite) which undergoes reversible expansion on absorbing water; any of a group of clay minerals of which montmorillonite and saponite are members.
<i>Specific Gravity (SG)</i>	A mineral's specific gravity is the ratio of its mass to the mass of an equal volume of water. Specific gravity measures the density of a material.
<i>spirals</i>	Gravity concentration devices for fine minerals.
<i>strike</i>	Horizontal direction or trend of a geological structure.
<i>tectonic</i>	Pertaining to the forces involved in, or the resulting structures of, movement in the earth's crust.
<i>XRD</i>	X-ray diffraction - The scattering of x-rays by crystal atoms, producing a diffraction pattern that yields information about the structure of the crystal.

XRF

X-ray fluorescence - is the emission of characteristic "secondary" (or fluorescent) X-rays from a material that has been excited by bombarding with high-energy X-rays or gamma rays. The phenomenon is widely used for elemental analysis and chemical analysis, particularly in the investigation of metals, glass, ceramics and building materials, and for research in geochemistry, forensic science and archaeology.