

# TECHMIRE

*die casting solutions*

LATEST MULTIPLE-SLIDE TECHNOLOGY



## 46NTX

Building on its expertise as the world's leading producer of high speed, multiple-slide die casting machines, TECHMIRE has introduced the 46 NTX model, featuring a larger four-slide crosshead assembly capable of accepting 101,6 mm x 152,4 mm (4" x 6") die segments. This significantly increases the clamping area to offer higher productivity with the proven benefits of a four-slide locking system with parting-line injection technology.

The machine features a die size ideal for producing zinc components weighing up to 11.5 oz (327 grams) with tight tolerances at fast cycle speeds.

# 46NTX

		STANDARD		OPTIONAL	
SLIDES	Number of Die Motions	4	8	8	8
	Die Size	4.00 in x 6.00 in	101.6 x 152.4 mm		
	Stroke of Each Die Section	0 ↗ 2.00 in	0 ↗ 50.8 mm	0 ↗ 3.00 in	0 ↗ 76.20 mm
	Ejector Stroke	1.00 in	25.4 mm	1.97 in (max)	50.04 mm (max)
	Maximum Total Die Opening	4.00 in	101.6 mm	6.00 in	152.4 mm
INJECTION	Injection Plunger Diameter	1.625 in	41.27 mm	1.00 / 1.25 / 1.875 in	25.4 / 31.75 / 47.625 mm
	Injection Cylinder Diameter	3.25 in	82.55 mm	2.00 in / 2.50 in	50.80 / 63.50 mm
	Injection Plunger Stroke	2.36 in	60.00 mm		
	Maximum Dry Shot Speed at 1,000 psi/70 bars*	55 in/sec	1.40 m/sec	85 / 150 in/sec	2.16 / 3.81 m/sec
	Injection Capacity (max.theoretical)*	17.3 oz	490 g	6.6 / 10.3 / 23.1 oz	187 / 292 / 655 g
	Shot Weight (max.recommended)*	8.65 oz	245 g	3.3 / 5.1 / 11.5 oz	93 / 146 / 327 g
	Metal Pressure (max.recommended)*	4000 psi	275.8 bars		
	Nozzle Heater	3.2 kW	3.2 kW		
HYDRAULICS*	Hydraulic Line Pressure (max)	1867 psi	128.6 bars		
	Hydraulic Tank Capacity	30 gallons	113.5 liters		
	Clamping Force	25 tons	22.67 tonnes		
	Dry Cycle Speed / Hour	3600	3600		
	Motor Power	20 HP	14.9 kW		
MELT POT (ELECTRIC)	Heaters	25.2 kW	25.2 kW		
	Capacity of Melt Pot	400 lbs	181 kg		
	Melt Rate / Hour	218 lbs	99 kg	258 lbs	117 kg
MELT POT (GAS)	Burner	110,000 Btu/hr	32.2 kW		
	Capacity of Gas Heated Melt Pot	400 lbs	181 kg		
	Melt Rate / Hour	232 lbs	105 kg		

\* Dependent upon machine configuration

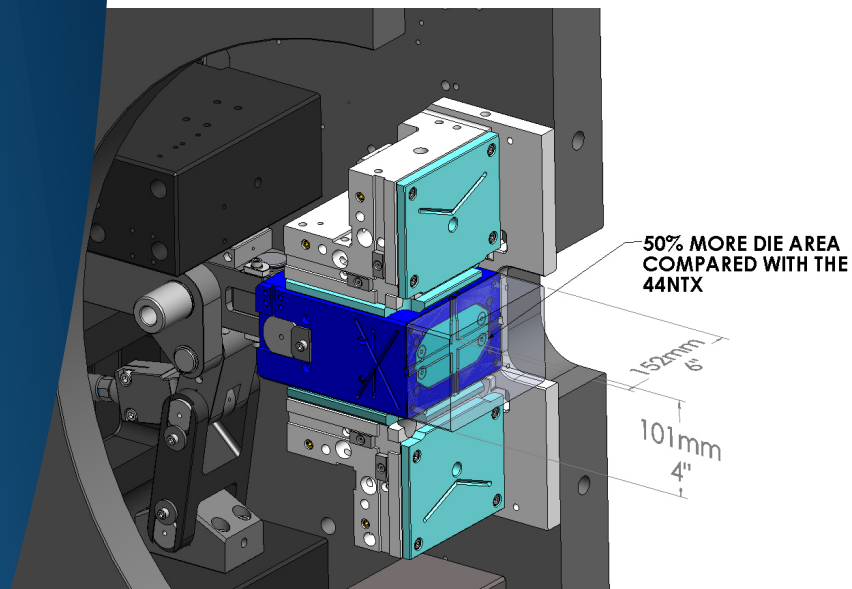

## TECHMIRE

die casting solutions

185, rue Voyageur  
Pointe-Claire, Québec  
Canada H9R 6B2

Tel.: (514) 694-4110  
Fax: (514) 694-2634  
www.techmire.com