

## EXECUTIVE PRO EM 120-HR

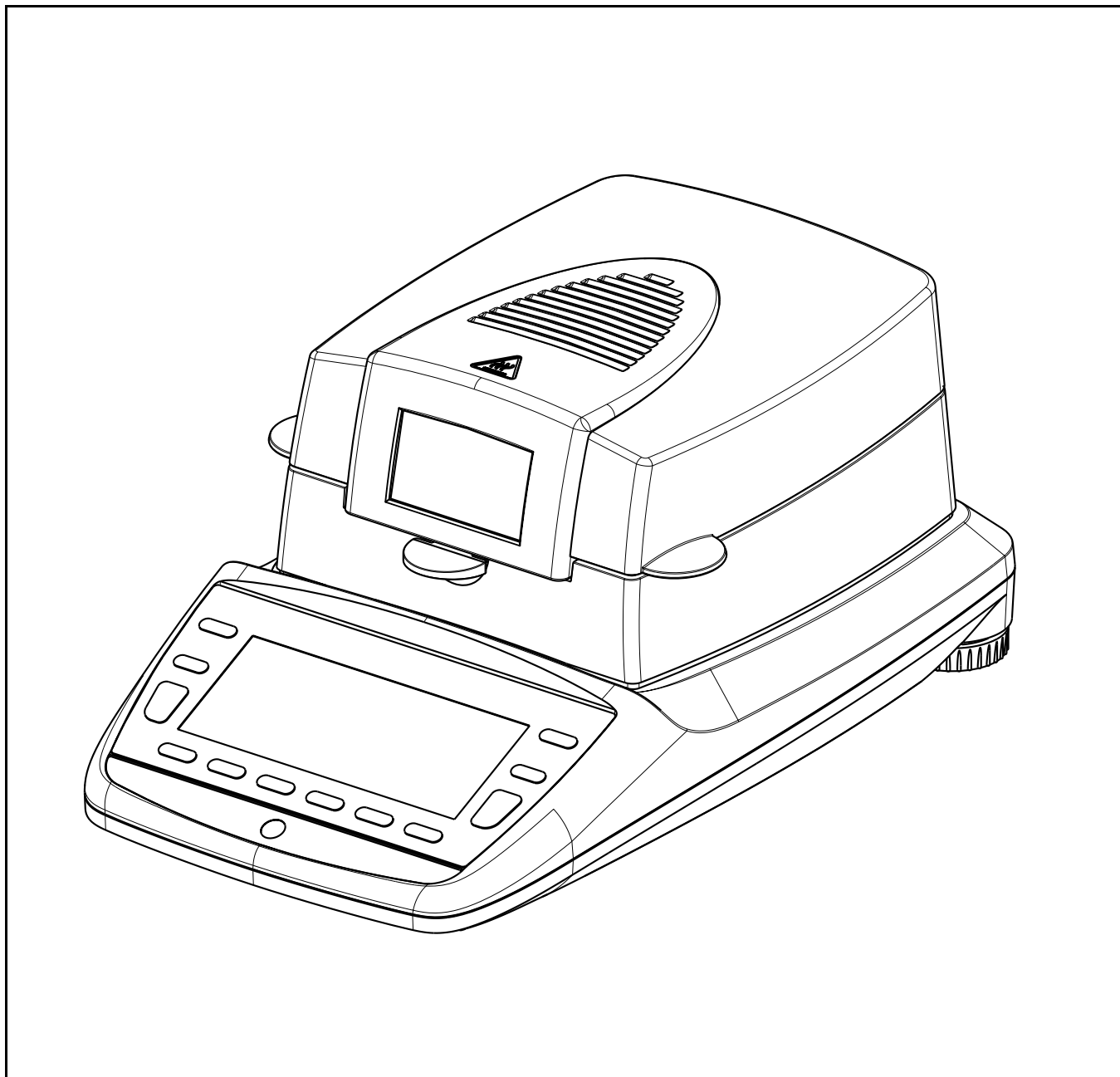

Operating Instructions

# Identification

## Customer service

Precisa Gravimetrics AG  
Moosmattstrasse 32  
CH-8953 Dietikon  
Tel. +41-44-744 28 28  
Fax. +41-44-744 28 38  
email [service@precisa.ch](mailto:service@precisa.ch)

<http://www.precisa.com>

Refer to our website for information about local customer service centers and details of their addresses.

## Copyright

These operating instructions are protected by copyright. All rights reserved. No part of the operating instructions may be reproduced, processed, duplicated or published in any form by photocopying, microfilming, reprinting or other process, in particular electronic means, without the written agreement of Precisa Gravimetrics AG.

© Precisa Gravimetrics AG, 8953 Dietikon, Switzerland, 2011

# 1 Overview

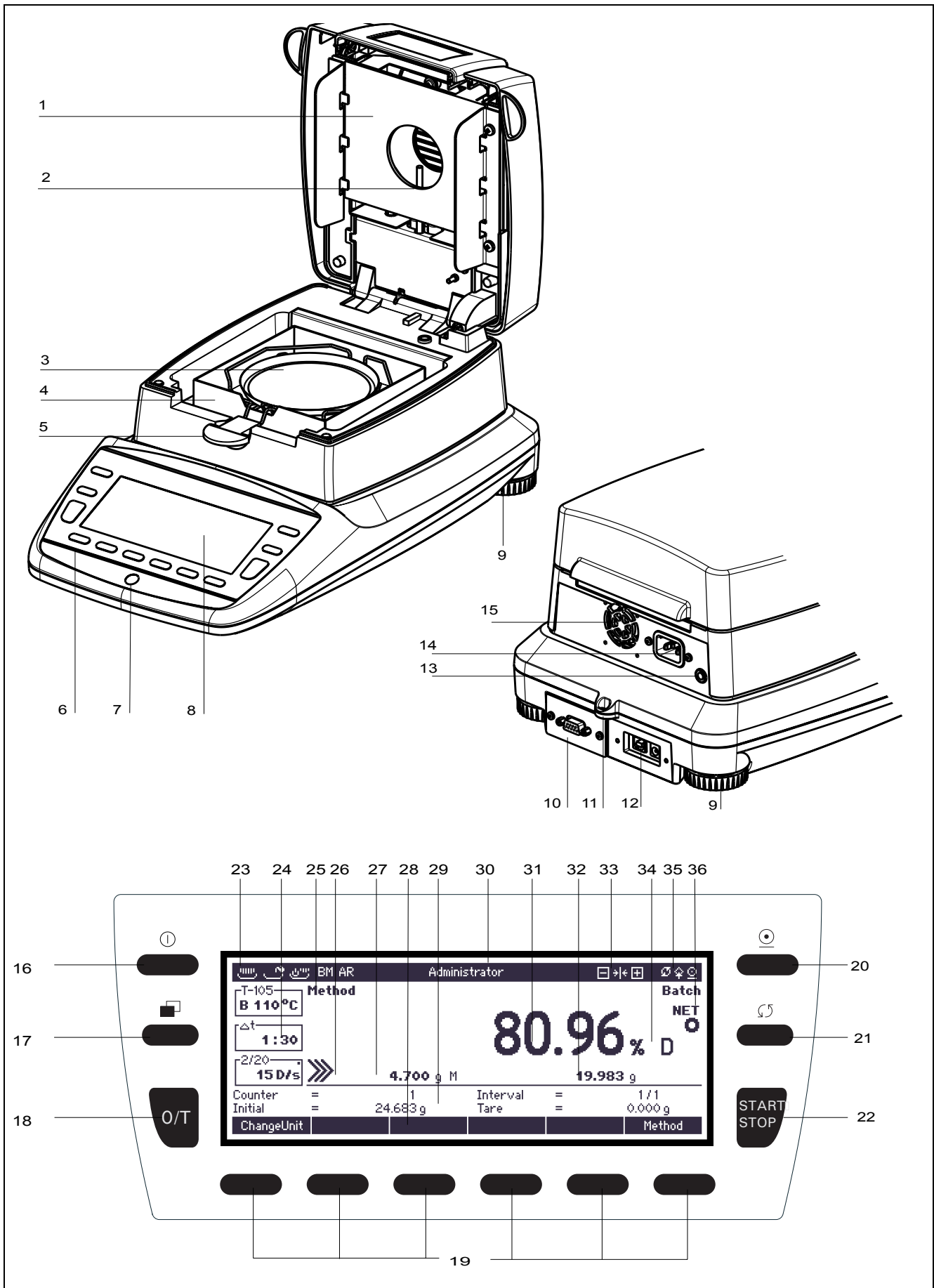

No.	Description	No.	Description
1	Heater	19	Soft keys
2	PT100 temperature sensor	20	Print key
3	Sample pan	21	Rotate key
4	Draftshield	22	Start / Stop key
5	Sample pan holder	23	Dryer mode and status
6	12-key control panel	24	Drying parameters
7	Levelling bubble	25	Method name
8	Display	26	Dryer status
9	Adjustable feet	27	Secondary display
10	Serial interface, DB9 Female socket	28	Function bar
11	Mechanical anti-theft protection	29	Info Page area
12	USB device connector for connection to PC	30	Headline
13	Mains fuse	31	Primary display
14	Mains connection socket	32	Third display
15	Fan	33	Check weigher
16	On/Off key	34	Unit
17	Menu key	35	Activity area
18	Tare / Zero key	36	Common status indicators

## ■ 2 Inspection and assembly

# 2 Inspection and assembly

Inspect delivery for complete supply immediately on unpacking all components.

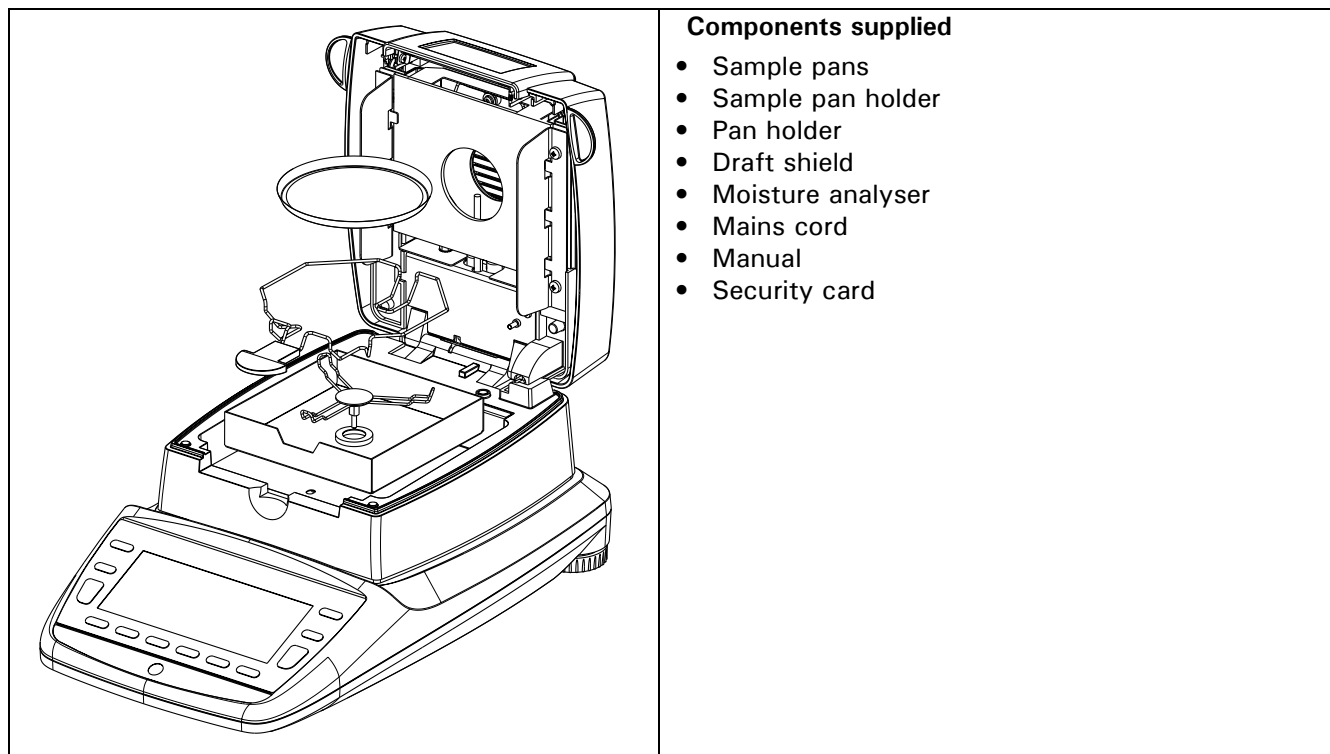

The moisture analyser is delivered in partly dismantled condition. Assemble the individual components in the following sequence:

- Install the draft shield
- Insert the pan holder and verify the position is locked
- Place the sample pan holder according to the drawing
- Place the sample pan in position
- Insert the mains cord into the mains connection socket at the rear

### ! NOTE

New screwdriver is required for assembly.

All parts must fit together easily. Do not apply force. Customer Service will be pleased to help you with any problems.

## 3 Accessories

Accessorie	Article number
Aluminium pans (box of 80)	350-2032
Stainless steel dish, reusable (1 pcs.)	330-2018
Fiber glass filters (box of 80)	350-4130
Printer 230V - with cable and paper roll	350-8379
Printer 115V - with cable and paper roll	350-8380
Roll of paper	350-8366
Ribbon	350-8367
Data cable DB9 Male / DB9 Female (PC), 1.5m	350-8672

<b>Accessorie</b>	<b>Article number</b>
Data cable DB9 Male / DB25 Male (Printer), 1.5m	350-8673
Temperature sensor plate (Sensor - type K)	350-8580
Temperature calibration set (Senosr - type K) with certificate	350-8585
Temperature calibration set (Senosr - type K) without certificate	350-8584
50 g adjustment weight	350-8241

## ■ Contents

<b>1</b>	<b>Overview .....</b>	<b>2</b>	<b>Application .....</b>	<b>31</b>
<b>2</b>	<b>Inspection and assembly .....</b>	<b>4</b>	<b>10.2 Functions of the Keys if Operated in a Menu</b>	<b>32</b>
<b>3</b>	<b>Accessories .....</b>	<b>4</b>	10.2.1 Soft Key Functions for Navigation and Data Entry.....	32
<b>4</b>	<b>Safety Instructions and Conformity</b>	<b>8</b>	10.2.2 Soft Keys and Soft Key Assignments .	32
4.1	Conformity .....	8	<b>10.3 The Display (as it appears during a running measurement) .....</b>	<b>33</b>
4.2	Safety Instructions .....	8	10.3.1 Info Pages and Info Fields.....	34
<b>5</b>	<b>Setup .....</b>	<b>10</b>	<b>10.4 The Info window .....</b>	<b>34</b>
5.1	Unpacking .....	10	<b>11 The Home Screen .....</b>	<b>35</b>
5.2	Transport and Shipping .....	10	11.1 The User Menu.....	35
5.3	Storage .....	10	11.2 The Settings Menu .....	35
5.4	Choosing a Suitable Location .....	11	<b>12 Context Menu .....</b>	<b>37</b>
5.5	Connecting the Moisture Analyser to the Mains.....	11	12.1 Method management .....	38
5.6	Safety measures.....	11	12.1.1 Quick Access 1-4 .....	38
5.7	Levelling.....	12	12.2 Batch/Measurement .....	38
5.8	Weight Calibration .....	12	12.3 Protocol .....	39
5.9	Switching on the Moisture Analyser... ..	12	12.3.1 Protocol - Header/Footer.....	39
5.10	Auto-Standby Mode.....	12	12.3.2 Proctocol - Method .....	42
<b>6</b>	<b>First Measurement .....</b>	<b>13</b>	12.3.3 Protocol - Measurement.....	44
<b>7</b>	<b>Determining moisture levels ....</b>	<b>16</b>	12.3.4 Protocol - Result.....	46
7.1	Fundamental principles .....	16	12.4 Screen settings .....	47
7.1.1	Adjusting to the existing measuring process	16	12.5 Identification.....	47
	16		12.6 Soft key .....	48
7.2	Sample preparation .....	16	12.7 Info Fields.....	49
7.2.1	Preventing samples being encrusted... ..	17	<b>13 The Configuration .....</b>	<b>51</b>
<b>8</b>	<b>Create a new Method .....</b>	<b>18</b>	13.1 Setup Configuration Menu .....	51
8.1	Create the First Method with NEW.....	18	13.1.1 The Setup Configuration Menu .....	51
8.1.1	Interval:.....	20	13.2 Configuration - Weighing parameters..	52
8.1.2	Checkweigher .....	22	13.3 Configuration - Calibration .....	52
8.2	Edit an Existing Method/ Create a new Method by Editing an Existing one .....	22	13.4 Configuration - Protocol.....	53
8.3	Edit an Existing Method with Fast Access	23	13.4.1 Configuration - Protocol - Autostart ...	54
<b>9</b>	<b>Measurement .....</b>	<b>24</b>	13.4.2 Configuration - Protocol - Mode.....	54
9.1	Open an existing method from the method list.....	24	13.4.3 Configuration - Protocol - Value format	54
9.2	Open method with Quick Access.....	25	13.4.4 Configuration - Protocol - Header/Footer (common items) .....	57
9.3	Start the measurement.....	25	13.5 Configuration - Interface .....	60
9.4	During the Analysis.....	25	13.6 Configuration - Device settings.....	60
9.5	Results, Data Handling and Statistik... ..	27	13.7 Configuration - Date/Time .....	61
9.6	Measurement with calculation of ash residue. ....	29	13.8 Configuration - Properties .....	61
<b>10</b>	<b>Operation.....</b>	<b>31</b>	<b>14 The Administrator and the User Profiles.....</b>	<b>62</b>
10.1	Functions of the Keys if Operated in an		14.1 The Administrator Menu .....	62
			14.1.1 Administrator - Define user .....	62
			14.1.2 Administrator - Define administrator...	64
			14.1.3 Administrator - Theft protection .....	64
			14.2 Resetting to the Factory Configuration	65
			<b>15 Data Transfer .....</b>	<b>66</b>

**15.1 Connection scheme ..... 66**  
**15.2 Remote control-commands ..... 67**  
 15.2.1 Examples for the remote control..... 67

**16 Maintenance and Servicing ..... 68**  
**16.1 Utility program ..... 68**  
**16.2 Calibration ..... 68**  
 16.2.1 External Calibration..... 68  
 16.2.2 External Calibration with Freely Selectable  
 Weight..... 69  
 16.2.3 Internal calibration ..... 69  
 16.2.4 Automatic Calibration ..... 69  
**16.3 Temperature calibration ..... 70**  
**16.4 Test measurement ..... 71**  
**16.5 Software Update ..... 71**  
**16.6 Cleaning ..... 72**  
**16.7 Replacing the mains fuse ..... 72**  
**16.8 Error Messages ..... 73**  
 16.8.1 Notes on Correcting Faults ..... 73

**17 Additional Information ..... 74**  
**17.1 Technical data ..... 74**



## 4 Safety Instructions and Conformity

### 4.1 Conformity

The moisture analyser has been manufactured and tested in accordance with the standards and directives set out in the enclosed certificate of conformity.

### 4.2 Safety Instructions

- When using the moisture analyser in surroundings with increased safety requirements, the corresponding regulations must be observed.
- Only use an extension cord with a protective earth conductor.
- Be sure to hold the plug, not the cable, when disconnecting the moisture analyser from an electrical outlet.
- If the power cable is damaged unplug the moisture analyser immediately from the electrical outlet and keep it from inadvertent operation.
- If there is any reason to believe that it is no longer possible to operate the moisture analyser without danger, it must be immediately unplugged from the electrical outlet and kept from inadvertent operation.
- In carrying out maintenance work, it is essential to heed the instructions in the chapter "Maintenance and servicing" of the operating instructions.
- Do not operate the moisture analyser in an area subject to explosion risks or caustic atmospheres.
- Do not exceed the maximum permissible load of the dryer.
- When using the moisture analyser in combination with other appliances made by Precisa as well as with appliances produced by other manufacturers, the current regulations for the safe use of the relevant attachments and their application in accordance with instructions must always be observed
- The Operating Instructions must be read by everyone who has to operate the instrument and must be kept handy on-site at all times.



#### **DANGER**

**Before connecting the moisture analyser to the mains, be sure that the operating voltage stated on the moisture analyser power cable agrees with the local mains voltage. If it doesn't, the equipment must not be connected to the mains at all! In this case contact the Precisa Customer Service.**



#### **DANGER**

**Do not place any flammable materials on, under or beside the instrument.**

**Leave enough clear space around the instrument to prevent a build-up of heat.**

**The moisture analyser may not be used to analyze explosive, highly flammable samples.**

**Do not operate the moisture analyser in areas where there is any risk of explosion.**

**Sample materials which release toxic substances must be dried in a fume hood. Take care not to inhale any harmful vapors.**

**Ensure that no liquid seeps inside the instrument or into the connection ports on the back of the instrument.**

**If you spill any liquid onto the instrument, unplug it from the electrical supply immediately.**

**Do not operate the moisture analyser again until you have had it checked by a Precisa service engineer.**

**⚠ CAUTION**

Some of the parts, like the heating element and the viewing window, may become considerably hotter while it is in operation. Only touch the instrument using the handles provided.

Take care when you remove the sample. The actual sample, the heating unit and sample pans used may still be very hot.

The moisture analyser should generally be used for drying substances containing water. Sample materials which give off aggressive vapors (like acids) may cause corrosion problems to develop on parts of the instrument.

If any damage or injury occurs, liability and responsibility rest with the user.

**ⓘ NOTE**

If any damage or injury occurs, liability and responsibility rest with the user.

## ■ 5 Setup

# 5 Setup

## 5.1 Unpacking

The moisture analyser is delivered in an environmentally-friendly package, specifically developed for this precision instrument, which provides optimum protection for the instrument during transportation.

### NOTE

Retain the original packaging in order to avoid transportation damages when shipping or transporting the dryer and to allow the dryer to be stored in the best conditions if it is out of operation for an extended period.

In order to avoid damage, attention must be given to the following points when unpacking the moisture analyser:

- Unpack the moisture analyser carefully. It is a precision instrument.
- When outside temperatures are very low, the dryer should first be stored for some hours in the unopened transport package in a dry room at normal temperature, so that no condensation settles on the dryer when unpacking.
- Check the moisture analyser immediately after unpacking for externally visible damage. If you should find transport damage, please inform your Services representative immediately.
- If the moisture analyser is not to be used immediately after purchase but only at a later time, it should be stored in a dry place where fluctuations in temperature are as low as possible ( 5.3 "Storage").
- Read through these operating instructions, even if you already have experience with Precisa equipment, before you work with the moisture analyser and pay attention to the safety recommendations ( 4 "Safety Instructions and Conformity").

## 5.2 Transport and Shipping

Your moisture analyser is a precision instrument. Treat it with care.

Avoid shaking, severe impacts and vibration during the transportation.

Take care that there are no significant temperature fluctuations during the transportation and that the dryer does not become damp (condensation).

### NOTE

The moisture analyser should preferably be dispatched and transported in the original packaging to avoid transportation damage.

## 5.3 Storage

If you would like to take the instrument out of service for an extended period, disconnect it from the electricity supply, clean it thoroughly ( 16.6 "Cleaning") and store it in a place which meets the following conditions:

- No violent shaking, no vibrations
- No significant temperature fluctuations
- No direct solar radiation
- No moisture

### NOTE

The moisture analyser should preferably be stored in the original packaging, since this provides optimum protection for the dryer.

## 5.4 Choosing a Suitable Location

The dryer location must be chosen in such a way as to guarantee perfect operation of your instrument, so that the allowable ambient conditions and prerequisites are met and maintained:

- Put the moisture analyser on a solid, firm and preferably vibration-proof, horizontal base
- Make sure that the dryer cannot be shaken or knocked over
- Protect from direct solar radiation
- Avoid drafts and excessive temperature fluctuations
- Leave enough clear space around the instrument to prevent a build-up of heat.

### ! NOTE

With difficult conditions (where the dryer may be easily shaken or subject to vibration) the dryer can nevertheless provide accurate results through suitable adjustment of the stability control (see chapter 13.2 "Configuration - Weighing parameters").

## 5.5 Connecting the Moisture Analyser to the Mains

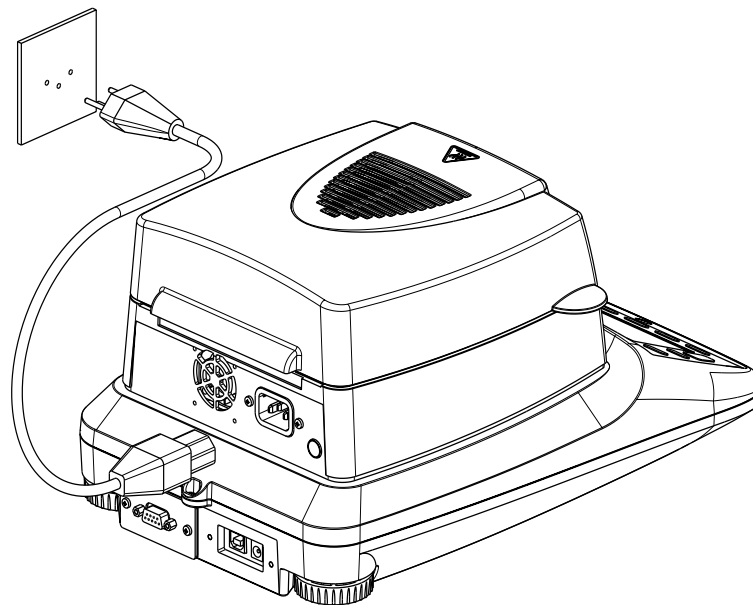

The following safety recommendations must be observed when connecting the instrument to the mains:

### ! DANGER

**The instrument may only be operated using the original mains cord supplied.**

**If the mains cord supplied is not long enough, only use an extension cord fitted with a protective earth conductor.**

**Plug the mains cord into a socket which has been installed in accordance with regulations and is fitted with a PE terminal..**

For technical reasons, the heating unit is designed in the factory to accommodate a voltage of 230 V or 115 V and in accordance with your order. Check that the setting matches the local setting? **If not the instrument must be connected to the mains supply. Contact the Customer Service.**

## 5.6 Safety measures

The moisture analyser may only be plugged into a grounded wall outlet. The safety effect may not be undone by using an extension lead without a ground wire. If the voltage is from a power source without a protective earth terminal, arrange for an electrician to create a comparable level of protection in accordance with local installation regulations.

## ■ 5 Setup

### 5.7 Levelling

To function properly, the moisture analyser must be precisely horizontal.

The instrument is fitted with one spirit level and two adjustable feet for level-control, with the aid of which it is possible to compensate for small height differences and/or unevennesses in the surface on which the moisture analyser is standing.

The two screw feet must be adjusted so that the air bubble is precisely in the centre of the sight glass of the bubble level.

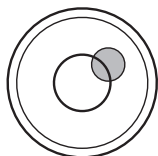

Incorrect

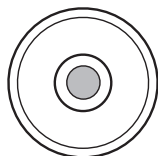

Correct

#### ! NOTE

In order to get exact measurements, the moisture analyser must again be carefully levelled after each relocation.

### 5.8 Weight Calibration

Since the Earth's gravity is not the same everywhere, each balance must – in accordance with the underlying physical weighing principle – be adjusted to compensate for the gravity at each location. This adjustment process, known as “calibration”, must be carried out on initial installation and after each subsequent relocation. In order to get exact measurements, it is recommended moreover, that the balance should also be calibrated periodically.

#### ! NOTE

The moisture analyser must be calibrated on initial installation and after every relocation. If you work in accordance with “Good Laboratory Practice GLP” observe the prescribed intervals between calibrations (adjustments).

Calibration is effected in the configuration menu. This may be done externally, internally or automatically (see chapters 13.3 “Configuration - Calibration” and 16.2 “Calibration”).

With the aid of the “Intelligent Calibration Mode” the balance can itself determine the size of the calibration weight, which enables an exact calibration with different size weights (in 10 g).

### 5.9 Switching on the Moisture Analyser

- Press «ON/OFF» to switch on the instrument

During the start-up sequence the moisture analyser executes a self check routine and stays, after about five seconds, ready in the same method before its last switching-off.

### 5.10 Auto-Standby Mode

The moisture analyser is equipped with an Auto-Standby mode, which can be activated or deactivated in the configuration menu.

If the Auto-Standby mode is activated, the moisture analyser automatically switches to Standby some time after the last weighing or key operation (current-saving function).

The delay before switching to Standby is defined in the configuration menu ( 13.2 “Configuration - Weighing parameters”).

- Press any button or put on a weight in order to switch the moisture analyser from the Standby mode back to the normal operation mode again.

## 6 First Measurement

Once the moisture analyser is successfully up and running, you can perform an initial measurement to familiarize yourself with the new instrument and to test it for any malfunctions.

Switch the instrument on using the «ON/OFF» key. The instrument performs a self-diagnostics test to check the main functions. After completion of the start-up process (which takes about ten seconds), "Zero" appears in the display; this means that the instrument is now ready for operation.

During the first measurement, the instrument uses the drying parameters set at the factory.

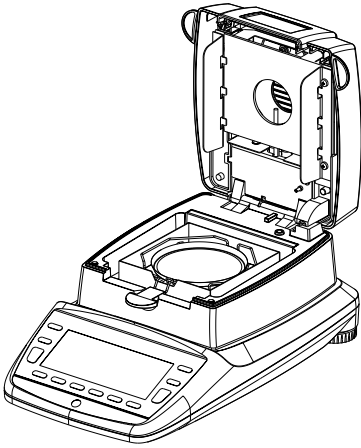

- Open the hood of the instrument
- Place the sample holder with an empty weighing pan onto the weighing pan holder.

Note: The weighing pan must sit flat on the weighing pan holder. Always work with the sample holder; it allows you to work safely and prevents possible burning ones self.



- Press the «TARE» key.

The instrument is ready to weigh the sample.

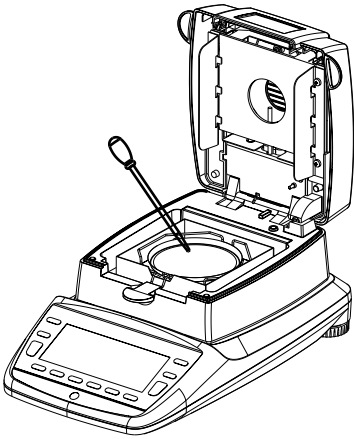

- Pour approx. 1.0 g of water into the weighing pan.

- Close the hood

The instrument is prepared for the first measurement.

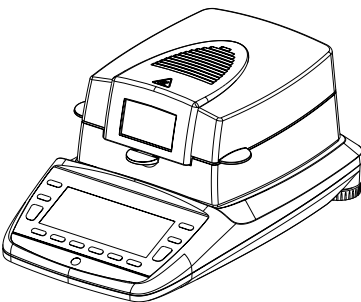

■ 6 First Measurement

- Start the measurement by pressing the «START/STOP» key.

The heating element heats up the chamber to 105°C, and the fan starts to cool.

- The standard screen is displayed

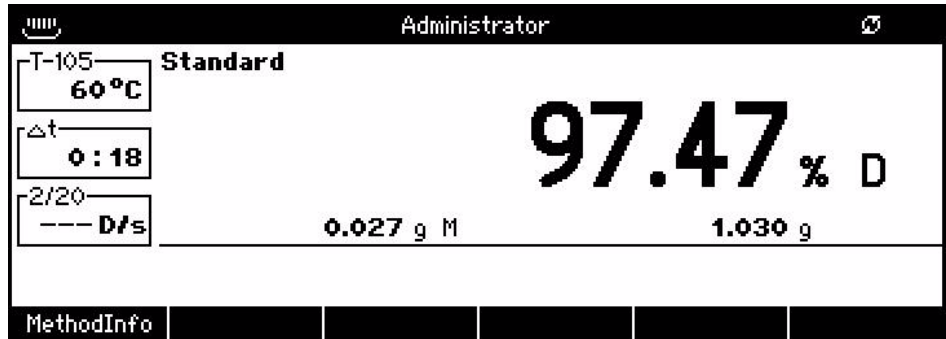

- Press «ROTATE» to call up the measurement screen (You can press «PRINT» at any time to have a printout of this information)

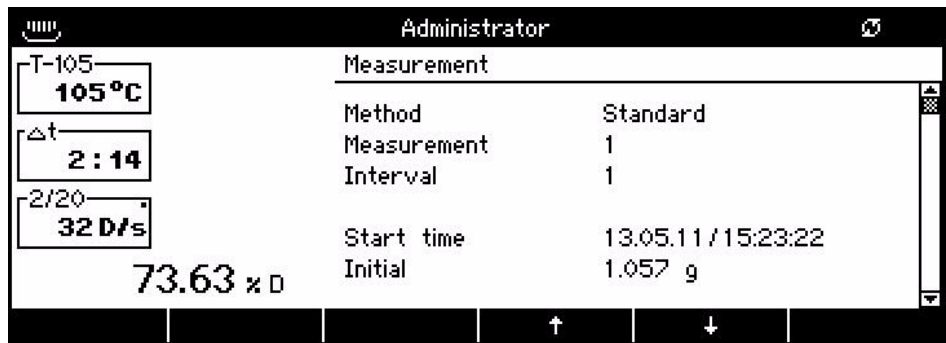

- Press «ROTATE» to call up the graph screen

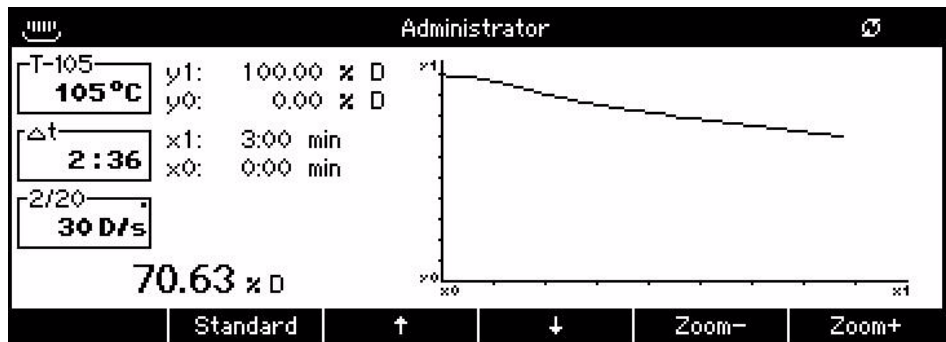

- Stop the measurement by pressing the «START/STOP» key.



The measurement would take some minutes until the instrument will stop with the current set auto stop criteria. For very wet samples like this a glass fibre filter is recommend to shorten the measuring time.

- The drying has ended, an audio signal sounds, and the heating is switched off. The fan keeps running until the temperature in the sample chamber drops below 40°C.

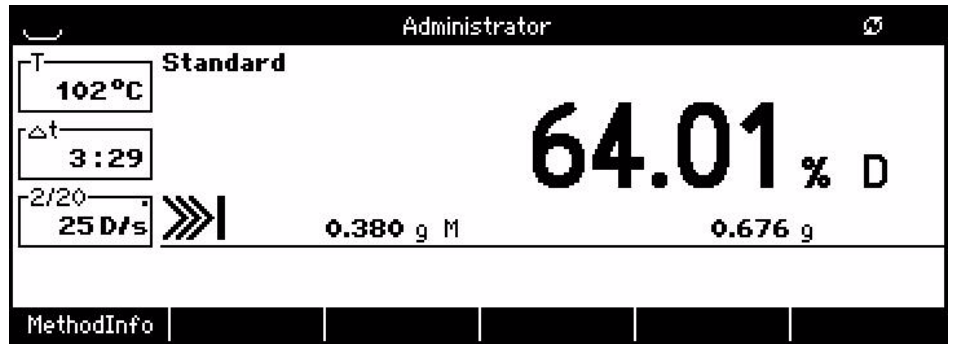

- Open the hood
- Carefully remove the weighing pan, only gripping the sample holder by the handle.

Caution! All the parts of the sample chamber are hot.

Allow the weighing pan and holder to cool down before doing anything else with them.

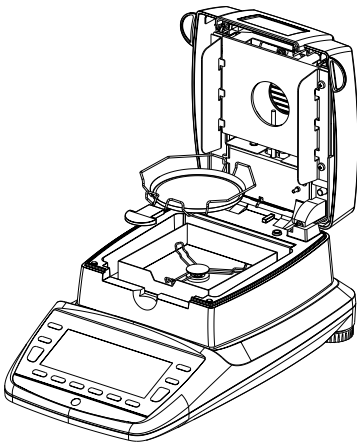

- Insert a new weighing pan into the instrument.
- Press the «TARE» Key; the instrument is ready for you to perform a new measurement.

**⚠ CAUTION**

The weighing pan and holder are hot!



## 7 Determining moisture levels

The moisture analyser is used as a quick and reliable means of determining the moisture content in powders and liquids by the thermogravimetric process.

### 7.1 Fundamental principles

The term moisture does not just relate to water, it also encompasses all substances which evaporate when they are heated. Alongside water, they also include

- fats
- oils
- alcohol
- solvents
- etc...

There are different techniques for determining the moisture of a material.

Thermogravimetry is the technique used in the moisture analyser. In this technique, the sample is weighed before and after heating so as to determine the moisture content from the difference.

The conventional drying oven technique works on the same principle except that, the measurement takes much longer. In the drying oven technique, the sample is heated from the outside inwards by a stream of hot air so as to draw out the moisture.

In the case of the halogen radiation used in the moisture analyser, the radiation mainly penetrates into the sample where it is converted into heat energy, heating the sample from the inside out. A small portion of the halogen radiation is reflected by the sample; this reflection is lower in dark samples than in light samples. The penetration depth of the halogen radiation depends on the permeability of the sample. In the case of low-permeability samples, the halogen radiation only penetrates into the upper layers of the sample, which may lead to incomplete drying, charring or combustion. Consequently, the sample preparation is extremely important.

#### 7.1.1 Adjusting to the existing measuring process

The moisture analyser is frequently used in place of other drying techniques (like the drying oven) because it is easier to operate and offers shorter measuring times. Consequently, the conventional measuring process has to be adapted to the moisture analyser so that comparable results can be achieved.

- Performing a parallel measurement
  - Lower temperature setting in the moisture analyser than in the drying oven technique
- The result achieved with the moisture analyser does not match the reference
  - Repeat the measurement with a changed temperature setting
  - Vary the switch-off criterion
- Adapting with the calibration curve or factor

### 7.2 Sample preparation

Prepare one sample at a time for measurement. This prevents the sample exchanging moisture with the ambient surroundings. If a number of samples have to be taken simultaneously, they should be packed in air-tight containers so as to ensure that they do not change while they are in storage.

Distribute the sample **evenly** and **thinly** on the weighing pan in order to achieve reproducible results.

If it is applied unevenly, this causes an inhomogeneous distribution of heat in the sample being dried, resulting in incomplete drying or an extension to the measuring time. If the sample is piled up, it heats up with greater intensity in the upper layers, causing combustion or encrustation to occur. The high layer thickness or possible formation of a crust prevents the moisture from escaping from the sample. This residual moisture means that measurement results achieved this way are not verifiable and reproducible.

**Solids:**

- Distribute powder samples evenly on the weighing pan.
- Make coarse samples smaller using a mortar or grinder. Do not expose the sample to any heat while you are grinding it as this will lead to a loss of moisture.

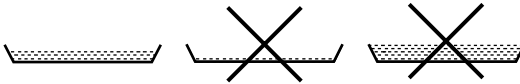
**Liquids:**

- You are advised to use a fiber glass filter for liquids, pastes or slurry samples. The fiber glass filter offers the following advantages:
  - even distribution on account of the capillary effect
  - no formation of drops
  - quick evaporation due to the larger surface

**7.2.1 Preventing samples being encrusted**

In order to avoid the sample becoming encrusted, solvent can also be added to the sample after the measurement has started. The solvent added has no bearing on the final result of the measurement.

- Set in the Method\Dryer Control „Refill“ to „On“.
- The moisture analyser hood can be opened during the analysis
- After opening the sample chamber, you can add additional solvent at any time until the hood is closed. Once the moisture analyser hood is closed, the measurement is continued. .

<b>! NOTE</b>
---------------

<p>The additional solvent is taken into account in the measurement printout because all the interim values are calculated on the basis of the current weight value.</p>
---

<p>However, it has no bearing on the drying result because the solvent has completely dried off.</p>
--

■ 8 Create a new Method

## 8 Create a new Method

Methods are arranged in groups to facilitate the organisation. Methods and groups can be identified by name and number.

Create a method with NEW method or by editing an existing method.

### 8.1 Create the First Method with NEW

Switch-on the moisture analyser:

Press «ON/OFF»

Create a new method:

- Press the soft key „Method

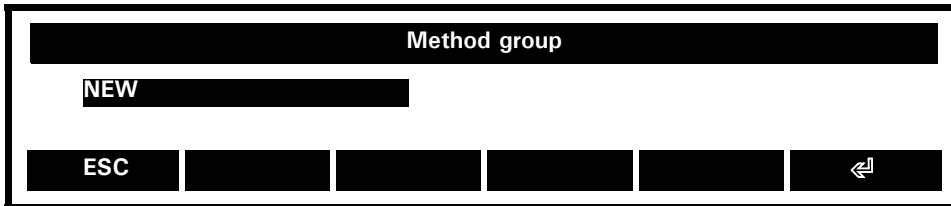

- Keep pressing {↓} until the menu item „NEW“ Method group is selected. (If no method group has been defined only „NEW“ is available.)
- Press {↵} to confirm your selection

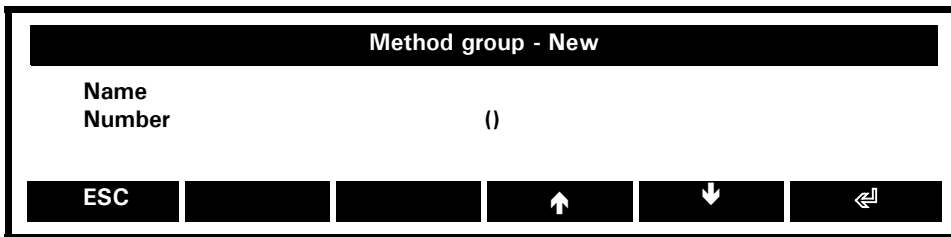

- Press {↵} to open the text entries window, Enter the Method Group Name, e.g. „DAIRY“:

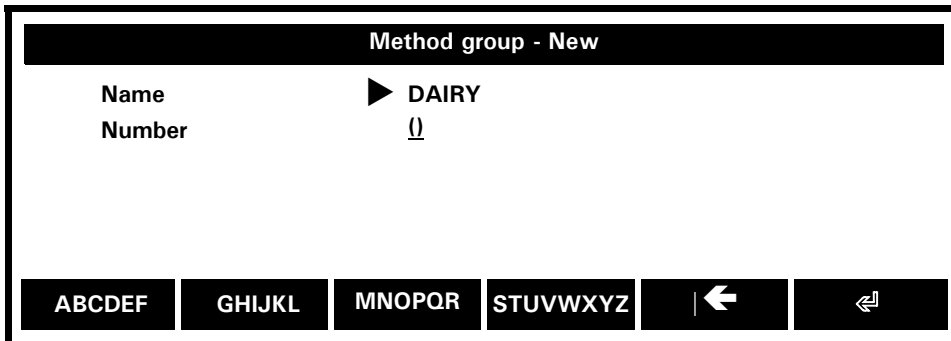

Doing text data entries, a wider range of additional soft key functions is available (observe the rotate symbol  in the activity area and call them up by pressing «ROTATE»):

abcdef	ghijkl	mnpq	stuvwxyz	←	E
ESC	V	,;?!@	_(){}[]	←	E
ESC	12345	67890	+ - * / = & %	←	E
ESC	.	,	DEL	←	↵

**! NOTE**

Executing text data entries, numbers put in with the soft key functions {12345} and {67890} act as characters, not as numeric values.

Is the text data entry completed

- Press {↵} to finish and save your input
- Press {↓} to select „Number“
- Press {↵} to confirm your selection
- Enter the group number, e.g. „1“
- Press {↵} to finish and save your input
- Press «ESC»
- Press {↵}
- Keep pressing {↓} until the menu item „NEW“ Method is selected. (If no method has been defined only „NEW“ is available.)
- Press {↵} to confirm your selection
- Define your method going through all parameters:

Method group - DAIRY - New method		1/2
Properties	▶ Show	
Name		
Number	()	
* Interval 1	Define	
Interval 2	Define	
Interval 3	Define	
ESC	←	→
	↑	↓
		↵

- Turn the page with {→}/ {←} respectively

Method group - DAIRY - New method		2/2
Resolution	Standard	
Standby temperature	Define	
Dryer Control	▶ Define	
CheckWeigher	Define	
Ash Residue	Define	
ESC	←	→
	↑	↓
		↵

**Properties: Show**

*Shows all settings of the method*

**Name:**

*Enter the name of the method*

**Number: ()**

*Enter the number of the method*

**Intervall 1-3:**

*A method consists of 1 to 3 intervals with individual temperature, heating mode, unit...  
The activated intervals are marked with an asterix. (See below)*

**Resolution: standard/heigh**

*Standard (d = 1 mg)*

*heigh (d = 0.1 mg)*

**Standby temperature:**

*Standby temperature (50 - 100 °C) which is holed inbetween two measurements*



Explanation of the variables used:

- DW: Dry weight (weight value at the end of the interval or measurement)
- MW: Moist weight (weight value at the start of the measurement)

Unit	Calculation
Loss % (moisture):	$\frac{MW - DW}{MW} \cdot 100\%$
Residual % (dry mass):	$\frac{DW}{MW} \cdot 100\%$
ATRO moisture:	$\frac{MW - DW}{DW} \cdot 100\%$
ATRO dry mass:	$\frac{MW}{DW} \cdot 100\%$
Loss g / kg [%]:	$\frac{MW - DW}{MW} \cdot 1000$
Residual g / kg [%]:	$\frac{DW}{MW} \cdot 1000$
Moisture in g:	MW - DW
Residual in g:	DW

- **Unit:** Choose the calculation and unit.
- **Result Base:** Select the value used as moist weight MW (is only available in Interval 2 and Interval 3)
- **Result correction factor:** Off, Weight unit, Percent unit  
Choose to correct the weighing result or the calculated value.  
Enter the correction factor

Calculations for Loss % and Loss g/kg using Sutrahend and Quotient which is only available in Interval 2 and Interval 3:

Explanation of the variables used

- DW: Dry weight (weight value at the end of the interval or measurement)
- SW: Weight used as subtrahend in calculation
- QW: Weight used as quotient in calculation

Unit	Calculation
Loss % (moisture):	$\frac{DW - SW}{QW} \cdot 100\%$
Loss g / kg [%]:	$\frac{DW - SW}{QW} \cdot 1000$

- **Subtrahend:** Select the value to use as subtrahend SW
- **Quotient:** Select the value to use as quotient QW
- **Result correction factor:** Off/Weight unit/Percent unit  
Choose to correct the weighing result or the calculated value.  
Enter the correction factor



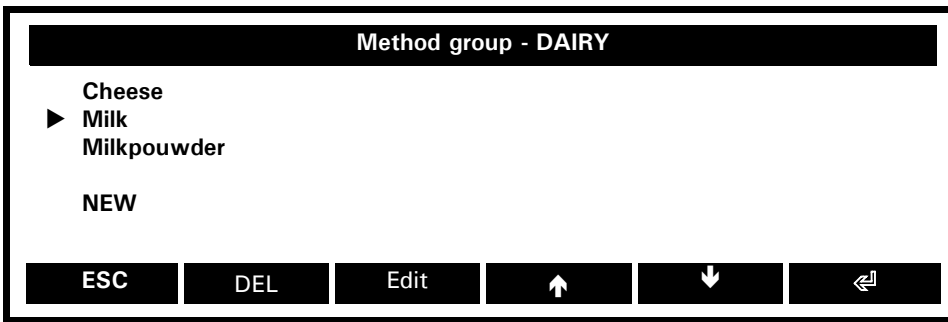

- Keep pressing {↓} until the method of your choice is selected
- Press {Edit}
- Define your method going through all parameters
- Change the name (and number) to store as new method. If the name of the method is not changed the old one is overwritten and all collected data are deleted.

### 8.3 Edit an Existing Method with Fast Access

- Set the soft key „Method fast edit“ see 12.6 "Soft key". You will now find the new key „MethodEdit“ in the function bar.



#### ! NOTE

With fast access editing no „save as“ is possible. Even if you rename the method the old method will be deleted. Work with 8.2 "Edit an Existing Method/ Create a new Method by Editing an Existing one" if you would like to keep both the old and new method.

- The method to be edited has to be open
- Press soft key {Method edit}
- Define your method going through all parameters
- With esc the new parameters are stored. The old method is overwritten



## 9 Measurement

### 9.1 Open an existing method from the method list

Switch-on the moisture analyser:

Press «ON/OFF»

Select the method:

- Press the soft key «Method»

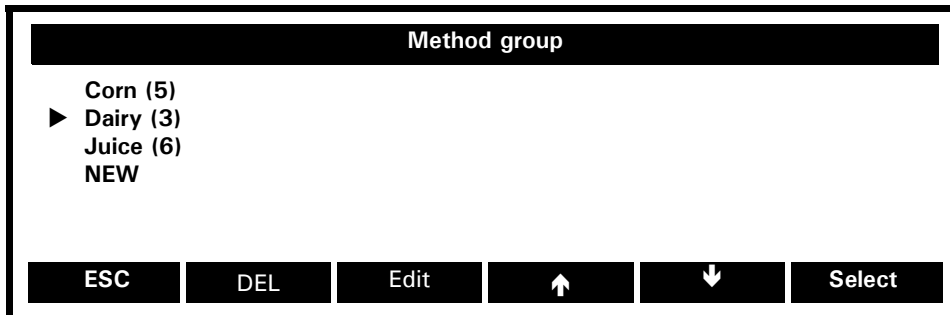

- Keep pressing {↓} until the method group of your choice is selected
- Press {↵} to confirm your selection

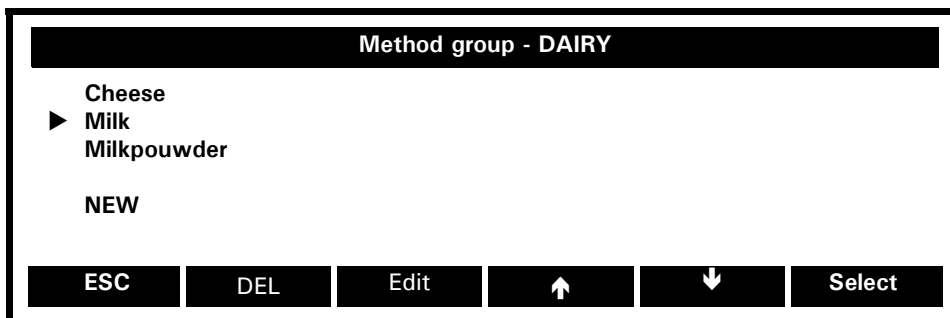

- Keep pressing {↓} until the method of your choice is selected
- Press {Select} to open the method

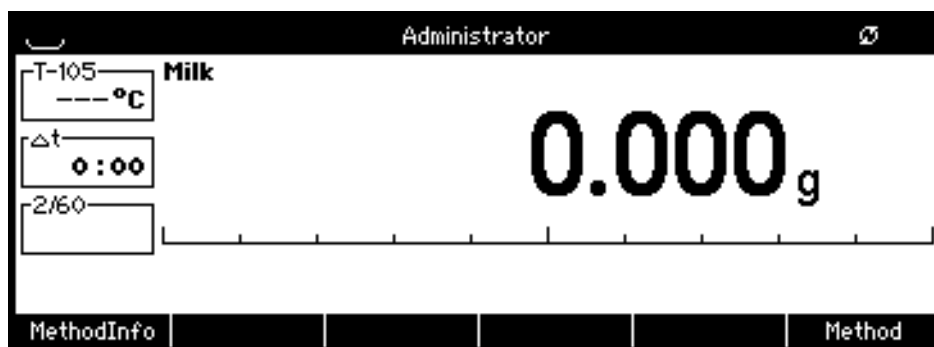

- (Press **{MethodInfo}** to see all settings of the chosen method, scroll down within the window)

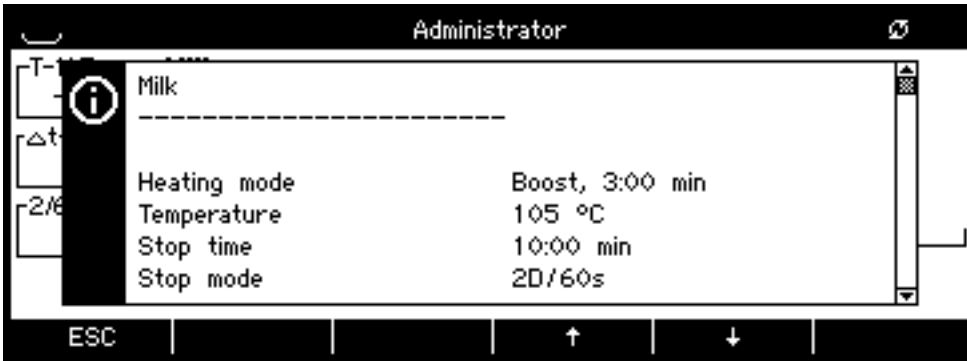

## 9.2 Open method with Quick Access

A quick access with soft keys for the four most frequently used methods is possible.

- Choose the methods for quick access in 12.1 "Method management".
- Set for each chosen method a soft key ( 12.6 "Soft key")
- You will find now the method soft keys in the function bar.



- Open the method by pressing the corresponding soft key.

## 9.3 Start the measurement

- Put the aluminium pan on the weighing pan
- Tare the balance **{0/T}**

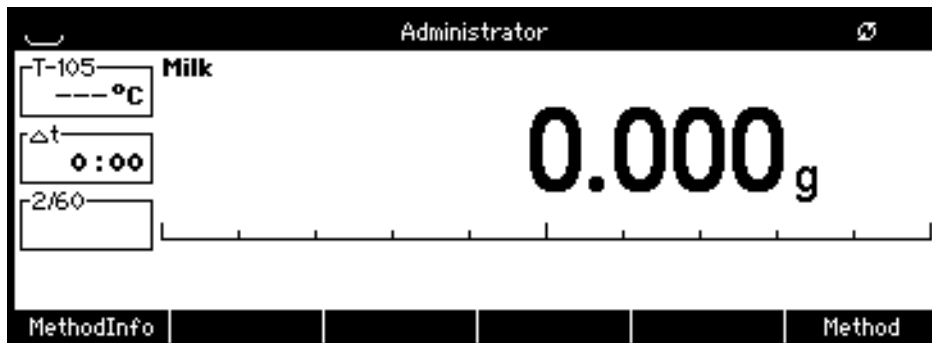

- Put the sample evenly on the aluminium pan
- Close the lid and start the measurement with **{START}**
- The measurement is stopped when the stop criteria is reached, the **{START/STOP}** key is pressed or the lid is opened (if „refill is activated lid opening doesn't stop the analysis)

## 9.4 During the Analysis

If activated in the context menu ( 12.4 "Screen settings") pressing **«ROTATE»** calls up further screens:

## ■ 9 Measurement

- Standard screen:

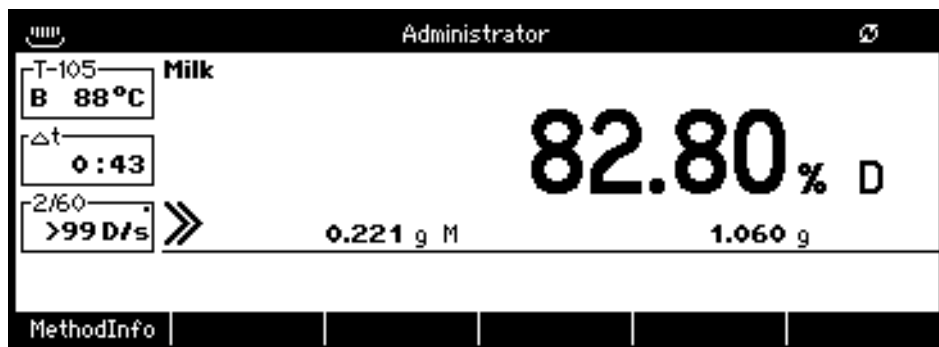

- Measurement screen: scroll down within the windows:  
(You can press «PRINT» at any time to have a printout of this information)

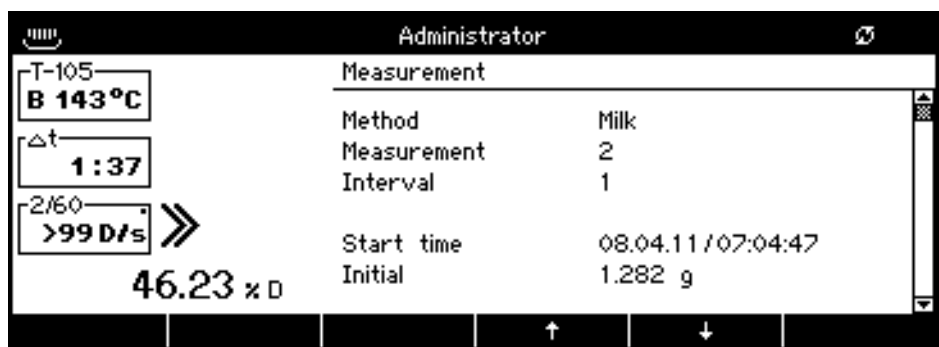

- Graphic screen:

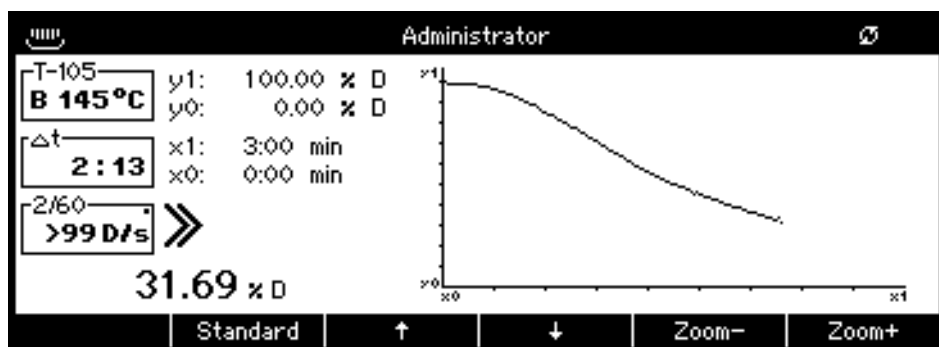

Information on the screen:

ICON	Designation	Function in a Menu
	no heating	• No heating: No analysis running or analysis has been interrupted for „refill“
	heating	• analysis is running or standby heating
	refill	• method allows solvent addition during analysis
	standby temperature	• method with standby temperature
	Checkweigher	• weighing in within tolerances

ICON	Designation	Function in a Menu
	Temperature	<ul style="list-style-type: none"> <li>• Temperature set and actual temperature</li> <li>• (temperature below 40 °C are displayed as --- °C)</li> </ul>
	Duration	<ul style="list-style-type: none"> <li>• actual time of analysis</li> </ul>
	Slope	<ul style="list-style-type: none"> <li>• stop mode set and actual slop</li> </ul>
	running	<ul style="list-style-type: none"> <li>• indicates the running analysis</li> </ul>
	finish	<ul style="list-style-type: none"> <li>• indicates the analysis has been finished</li> </ul>
Results		<ul style="list-style-type: none"> <li>• Main result in the calculation chosen in the method</li> <li>• value 2 and 3 as defined in the screen settings</li> </ul>

## 9.5 Results, Data Handling and Statistik

The userdefined report is automatically transferred to the connected printer/PC

If activated in the context menu ( 12.4 "Screen settings") pressing «**ROTATE**» calls up further screens:

- Standard screen:

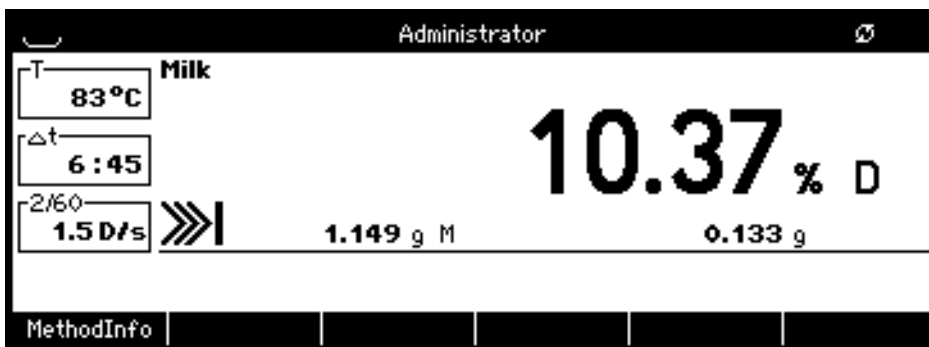

- Measurement information. Scroll down within the windows.

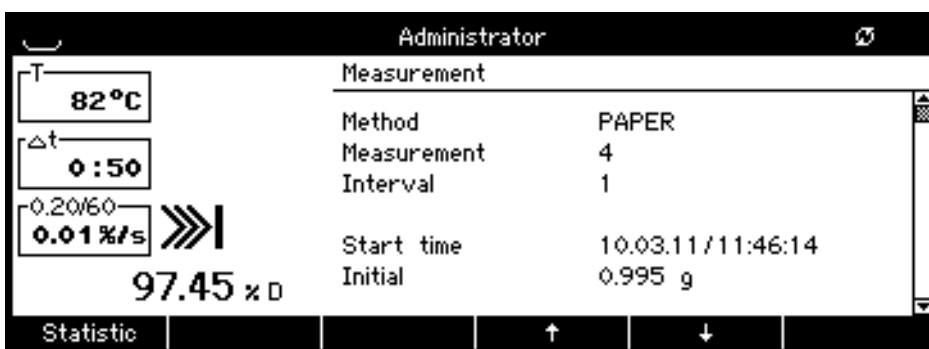

## ■ 9 Measurement

Graphic screen

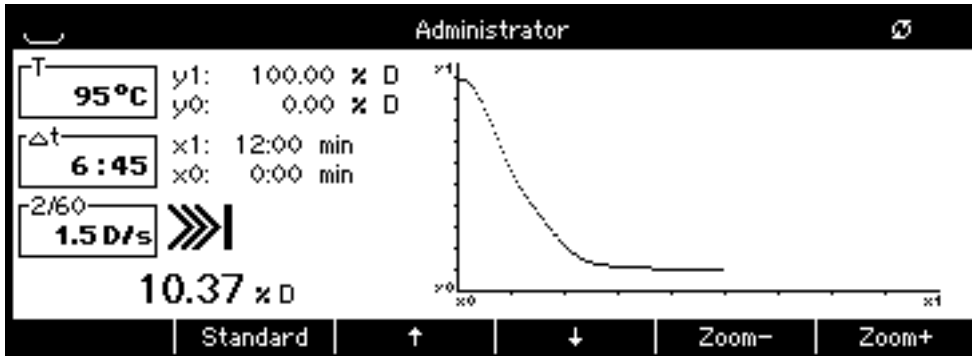

Zoom with „Zoom-“ and „Zoom +“ in steps of 10 %

### ! NOTE

Press «0/T» to close the measurement.

Press «ROTATE» to get to the measurement information screen. You do have access to the statistic and the last measurement information.

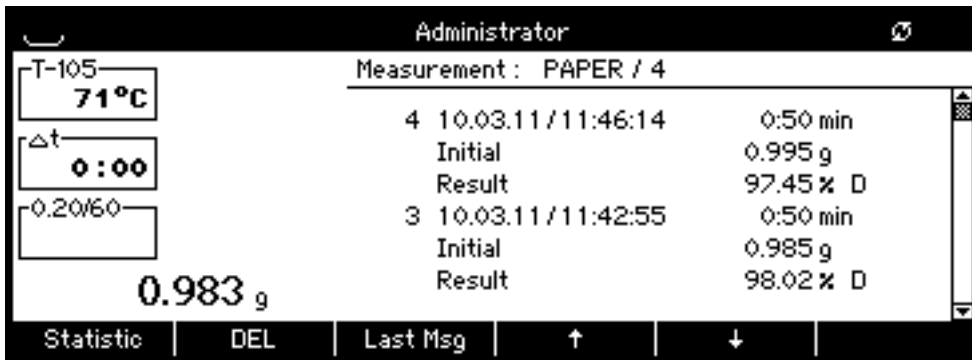

### Statistic

You have access to the following statistical information:

Statistik		Brief Information
Method	Paper	<b>Name</b> <i>Names the method name</i>
Measurement	3	<b>Measurement</b> <i>Number of measurements</i>
Mean	90.7 % D	<b>Mean</b> <i>Mean value in the chosen calculation</i>
Max.	91.89% D	<b>Maximum value</b>
Min.	89.42% D	<b>Minimal value</b>
StdDev.	1.244% D	<b>Standard deviation</b>
Std.Dev	1.37 %	<b>Relativ standard deviation</b> <i>(StdDev/Mean*100%)</i>

**DEL**

Delete single measurements or all measurements

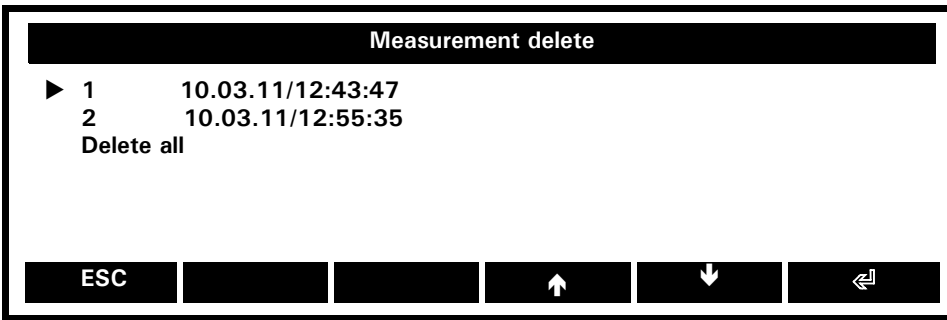

**LastMsg**

Information on the last measurement

**9.6 Measurement with calculation of ash residue.**

- Open the drying method ( Ash residue has to be set ON in this method)

Display	(Soft )key	Step
		<b>Start</b>
Press, <O/T>	O/T	Zero the balance with out tara vessel
Place pan, <assume>	Assume	Place the empty vessel on the balance . With <Assume> the tara weight is stored and the display is set to zero
Initial, <close the cover>		sample weighing in, the measurement is started automaticaly with closing the cover
Repeat step 1 to 4 for all samples Ash the samples with an adequate device		
↻		
		<b>AshResidue</b>
		<b>Residual 1</b>
Press, <O/T>	O/T	Zero the balance without the vessel

English

## ■ 9 Measurement

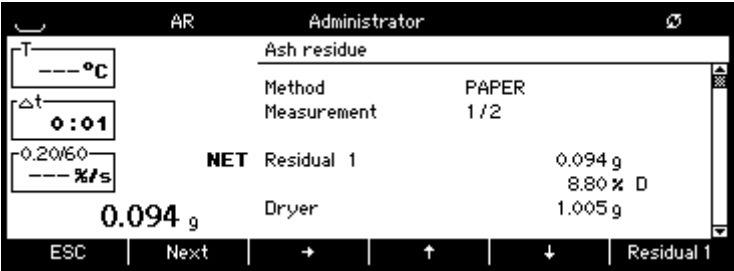
Display	(Soft )key	Step
Pan-Residual, < Assume >		Place the vessel with the ash residue on the balance. With < assume > the value is stored and the result calculated
	<p>Next</p> <p>resp.</p> <p>{→}</p>	<p>Change to the next sample to read the first residual</p> <p>If needed change to the second and third residual</p>

## 10 Operation

Even though your new dryer allows you a very easy and highly intuitive working, you should read through the following operating instructions at full length to tap the full potential of the wide variety of features the moisture analyser disposes to facilitate your daily work.

### The Keypad

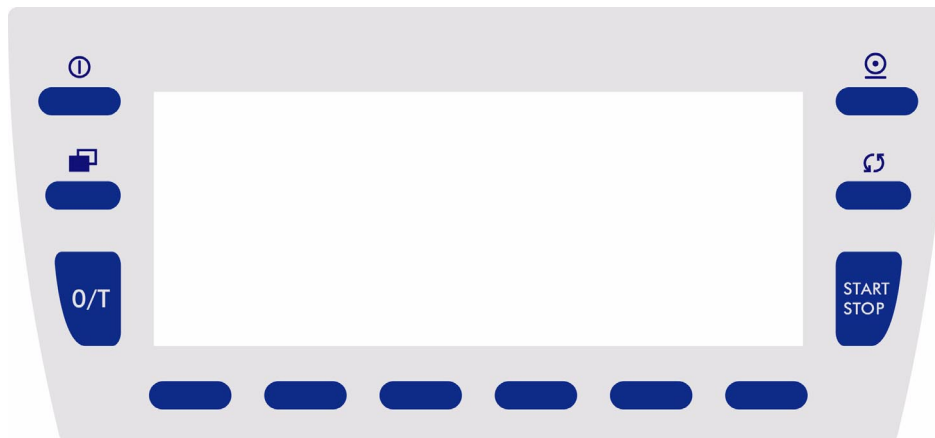









### 10.1 Functions of the Keys if Operated in an Application

Key	Designation	Function in an Application
	«ON/OFF»	<ul style="list-style-type: none"> <li>• Turns the moisture analyser on and off.</li> </ul>
	«PRINT»	<ul style="list-style-type: none"> <li>• Transmits the current measuring result or the content of an info window via interface to the peripherals.</li> </ul>
	«MENU»	<ul style="list-style-type: none"> <li>• Pressing leads to the context menu of the currently executed application.</li> <li>• Holding leads to the home screen from any point.</li> </ul>
	«ROTATE»	<ul style="list-style-type: none"> <li>• Pressing (only if adverted by the rotate symbol  in the activity area) exchanges the measuring results of the primary and the secondary display.</li> <li>• Holding calls up the next info page, continuously holding scrolls cyclically all info pages.</li> </ul>
	«O/T»	<ul style="list-style-type: none"> <li>• Pressing Close the measurement</li> <li>• Pressing re-zeroes, respectively tares the balance.</li> <li>• Holding leads to the utility program/calibration menu.</li> </ul>
	«START/STOP»	<ul style="list-style-type: none"> <li>• Starts/Stops the measurement</li> </ul>
	{SOFT KEY}	<ul style="list-style-type: none"> <li>• Each of the six soft keys executes its assigned function, displayed in the function bar, straight above the key itself. If displayed, pressing {→} or {←} calls up further soft key functions.</li> </ul>



## 10.2 Functions of the Keys if Operated in a Menu

Key	Designation	Function in a Menu
	«ON/OFF»	<ul style="list-style-type: none"> <li>• Turns the moisture moisture analyser on and off.</li> </ul>
	«PRINT»	<ul style="list-style-type: none"> <li>• Not functional.</li> </ul>
	«MENU»	<ul style="list-style-type: none"> <li>• Pressing leaves a menu.</li> <li>• Holding leads to the home screen from any point.</li> </ul>
	«ROTATE»	<ul style="list-style-type: none"> <li>• Pressing (only if adverted by the rotate symbol  in the activity area) calls up further soft key functions.</li> </ul>
	«O/T»	<ul style="list-style-type: none"> <li>• Not functional.</li> </ul>
	{SOFT KEY}	<ul style="list-style-type: none"> <li>• Each of the six soft keys executes its assigned function, displayed in the function bar, straight above the key itself. If available (displayed rotate symbol  in the activity area), pressing «ROTATE» calls up further soft key functions.</li> </ul>

### 10.2.1 Soft Key Functions for Navigation and Data Entry

{←}	{left}	Moves the cursor left / scrolls pages
{→}	{right}	Moves the cursor right / scrolls pages
{↑}	{up}	Moves the cursor up / scrolls up lines
{↓}	{down}	Moves the cursor down / scrolls down lines
{▲}	{switch}	Switches the icon-figured function above
{↵}	{Enter}	Selects a menu item / finishes and saves an input
{ESC}	{Escape}	Quits an input without saving the changes
{ ←}	{Backspace}	Deletes the character located on the left side of the cursor („_“)
{DEL}	{Delete}	Deletes the character located above the cursor („_“)
{ABCDEFG}	{Symbol entry}	Keep pressing until the desired symbol appears, e.g. twice for „B“. The same procedure is valid for all symbol entry functions, e.g. {+ -* / = & %} or {67890}
{_}	{Space}	Interword separation

### 10.2.2 Soft Keys and Soft Key Assignments

A soft key is a soft-coded key, a button, located alongside the display, which performs a function displayed near or right above it in the function bar at that moment. (In opposition to that, a hard key is a hard-coded key, which performs just its firmly assigned function, e.g. «ON/OFF».)

Depending on your needs you may assign a choice of various functions to the soft keys. If you assign more than 6 functions, a function {←} or {→} is displayed to switch from the current selection to the next.

### 10.3 The Display (as it appears during a running measurement)

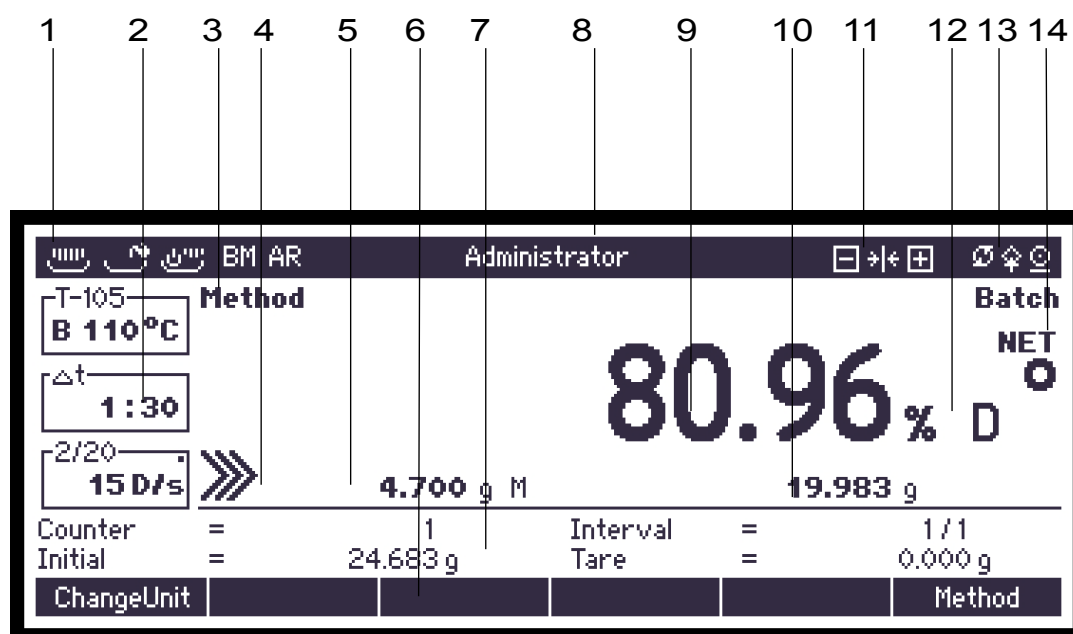













No.	Name of Display Section	Description
1	Status of dryer	• Icons shows if the moisture analyser is heating, if standby temperature or refill is activated in the actual method is activated.
2	Parameter	• Shows set and actual interval parameters
3	Method	• Shows the actual method
4	Analysis	• Displays if the analysis is still running or that it has already been finished
5	Secondary display	• Displays the weight lost of the current measurement
6	Function Bar	• Displays straight above every single soft key its, at the moment assigned, function.
7	Info Page Area	• Displays the selected info page, consisting of up to four assigned info fields available in the menu of the running application. This is to show information like tolerance limits when you are weighing in or various statistical data.
8	User	• Displays the current user
9	Primary display	• Displays the measuring result in the chosen calculated unit.
10	Third display	• Displays the remaining weight of the current measurement
11	CheckWeigher	• This smart aid supports you graphically, and by wish also acoustically, while weighing in.
12	Unit	• Shows the actual unit
13	Activity Area	<ul style="list-style-type: none"> <li>• A displayed rotate symbol  adverts that by pressing «ROTATE» further measurement displays are available.</li> <li>• A displayed print symbol adverts that the moisture analyser is busy transmitting the current measuring result or the content of an info window via interface to the peripherals.</li> <li>• A displayed data entry symbol adverts that the moisture analyser is ready to receive data, either via interface (e.g. from a barcode reader) or manually.</li> </ul>
14	Common status	<ul style="list-style-type: none"> <li>• Displays common status information of the dryer</li> <li>• Shows the actual batch</li> </ul>

## ■ 10 Operation

### 10.3.1 Info Pages and Info Fields

There is a screen section called „Info Page Area“ to display application specific information. Each info page has 4 info fields: top left, bottom left, top right and bottom right. In an application, holding the «**ROTATE**» key calls up the next info page and continuously holding it scrolls cyclically all info pages.

**Available info fields (quadrants) for displaying information on the info pages:**

 Page 1 / Top left	 Page 1 / Top right
 Page 1 / Bottom left	 Page 1 / Bottom right
 Page 2 / Top left	 Page 2 / Top right
 Page 2 / Bottom left	 Page 2 / Bottom right
 Page 3 / Top left	 Page 3 / Top right
 Page 3 / Bottom left	 Page 3 / Bottom right
...	

You may reconfigure the info pages at any time. Therefore switch the menu item Info fields in the context menu and assign the info fields individually.

### 10.4 The Info window

The Info Window is used to display large text information on the screen. You can press «**PRINT**» at any time to have a printout of the text in the info window.

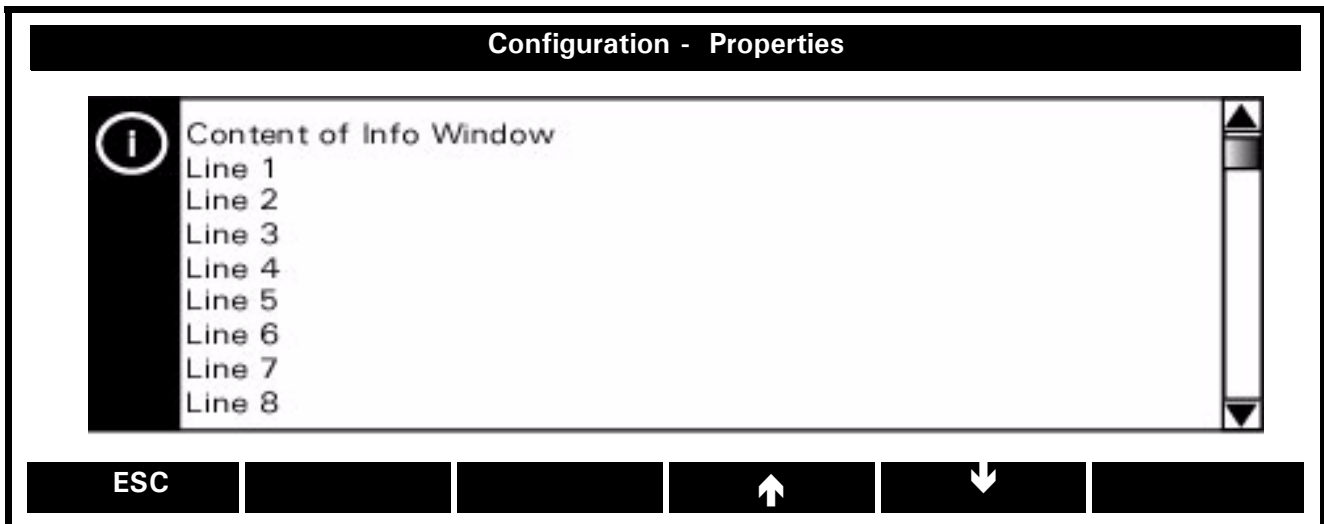

Pressing {↑} and {↓} scrolls the lines up and down, holding scrolls to the top and the bottom of the text. To exit the info window, press {ESC}.

# 11 The Home Screen

The home screen provides access to the various menus of the moisture analyser, which are listed in the white headline, just the part which displays the currently selected position is black (either User or Settings).

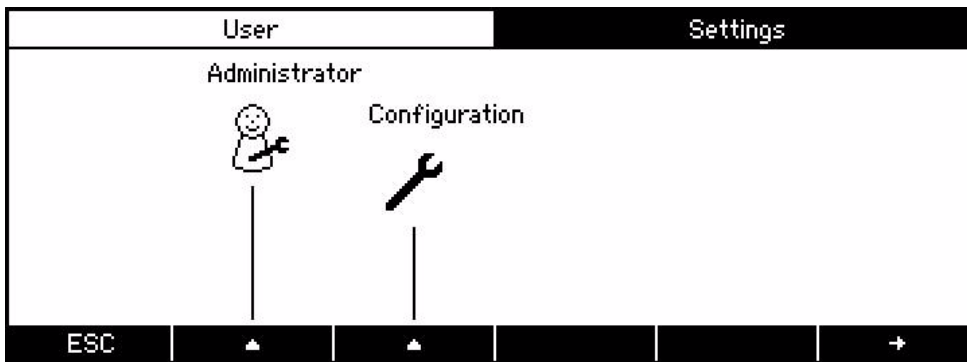

## 11.1 The User Menu

The user menu provides access to up to 8 different password protected user profile settings. Observe, that the user menu cannot be switched if no user profile is enabled. Learn more about defining user profiles in chapter 14.1.1 "Administrator - Define user"

- Hold «**MENU**» to switch the home screen
- Keep pressing {→} until the user menu is selected

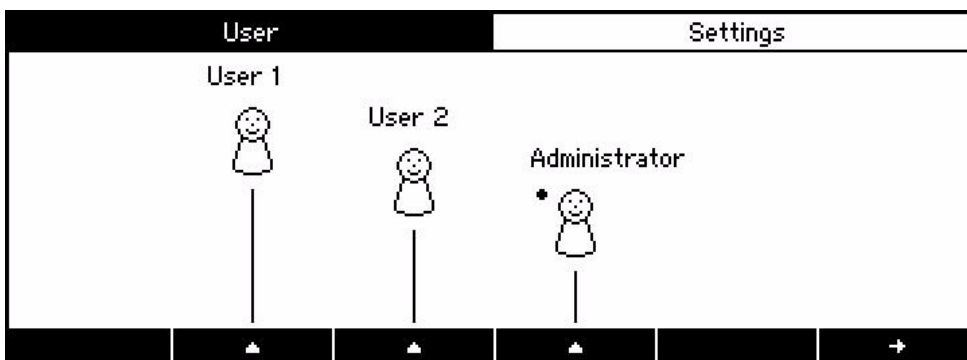

In case of more than four defined user profiles vertical scroll bars on the sides indicate that there are more user profiles from which to choose. As in the application menu, you may press {↓} to switch the second page and activate the particular user profile by pressing the correspondent {▲}.

## 11.2 The Settings Menu

The settings menu is where all moisture analyser settings can be done, such as defining the basic parameters, the administrator and user profiles, customizing applications or resetting to the factory configuration.

- Hold «**MENU**» to switch the home screen.
- Keep pressing {→} until the settings menu is selected

## ■ 11 The Home Screen

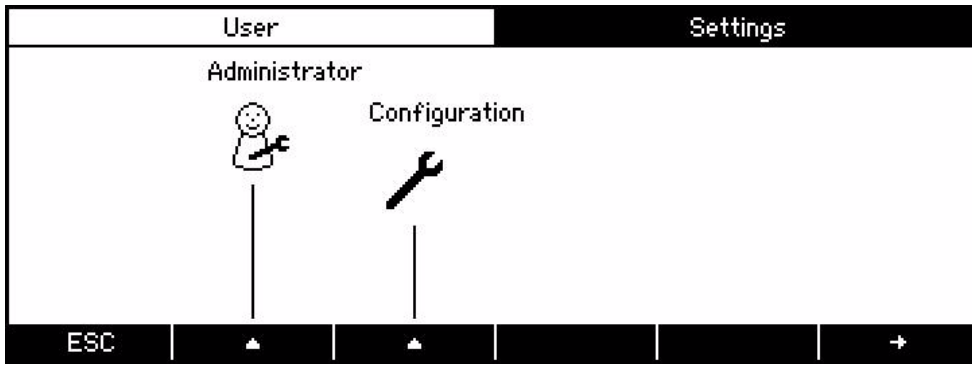

For particular information about all setting options, see the correspondent chapters 13 "The Configuration" and 14 "The Administrator and the User Profiles".

## 12 Context Menu

Navigating in the context menu:

- Press **{MENU}** to open the context menu  
(The headline names the menu and the function bar provides us with the needed navigation functions.)
- Keep pressing **{↓}** until the menu item of your choice is selected  
the left column names the single items, while the right one allows us to select and define them one by one.
- **{←}** **{→}** scrolls pages  
(The actual page and the number of pages are displayed at the right end of the headline, in our example „1/2“, i.e. page 1 of 2)
- Press **{↵}** to confirm your selection
- Press **{ESC}** to go back a level, changes are saved automatically

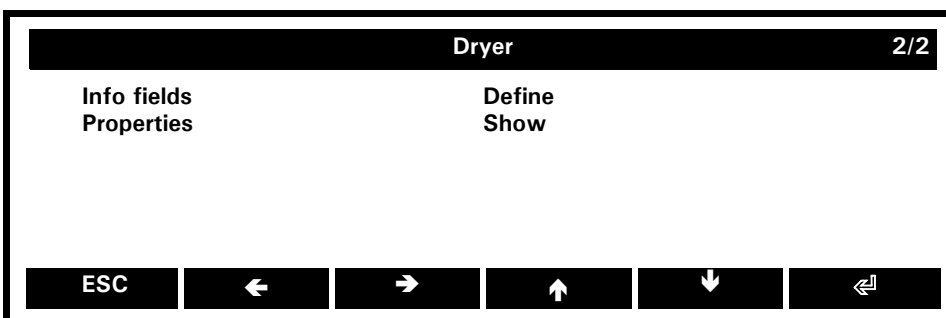
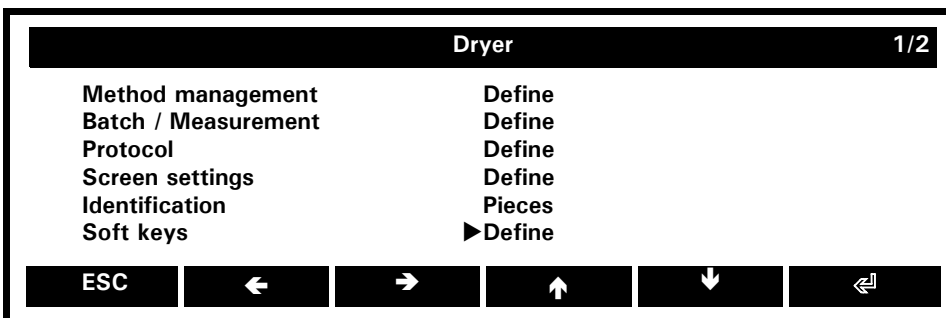

### Method management:

*Define Methods for quick access. Del. all methods*

### Batch / Measurement:

*Switch batch mode on and off, delet measurements*

### Protocol:

*General settings for the protocol/printout*

### Screen settings:

*Define Value/Measurement display*

### Identification:

*Defines the ID 1/2/3/4/5/6, see below*

### Soft keys:

*Define soft keys*

### Info field:

*Define info fields*

### Properties:

*Shows hardware and software information, all settings in protocol, screen settings, identification and soft keys*



**Properties: Show**

Shows the measurement memory with number of batches, number of defined/free measurements (up to 1000)

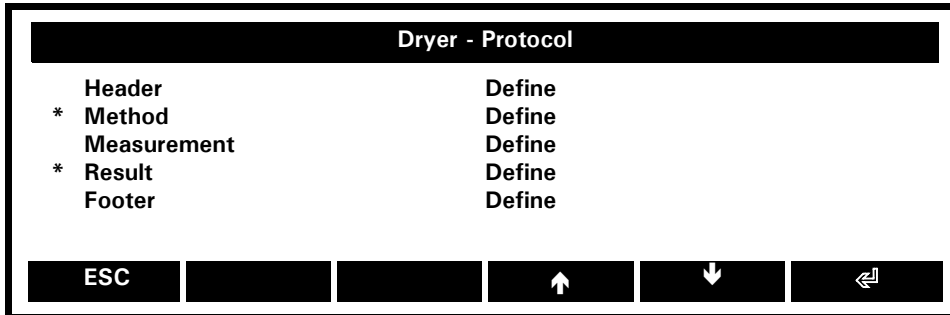
**12.3 Protocol**

On set menu items are marked with an asterisk and have to be defined (see below)

**12.3.1 Protocol - Header/Footer**

As the menu header and the footer menus differ just in the item „Position“, both are treated in this chapter.

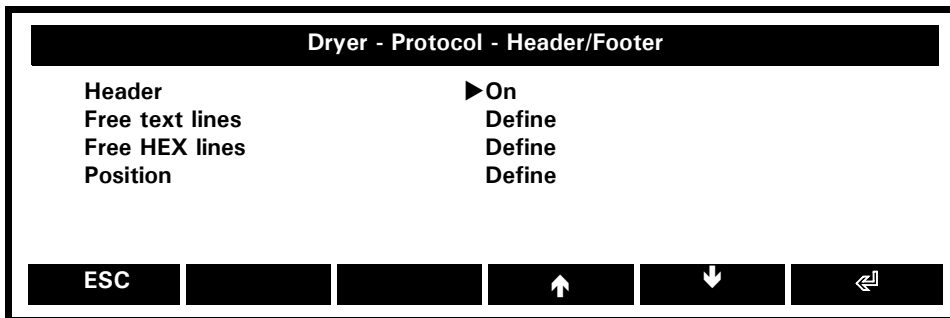
**Header/Footer: On, Off**

Header/Footer is enabled in printout

**Free text lines: Define**

Defines text lines for header/footer

**Free Hex lines: Define**

Defines hexadecimal output for header/footer

**Position: Define**

Defines positions in header/footer

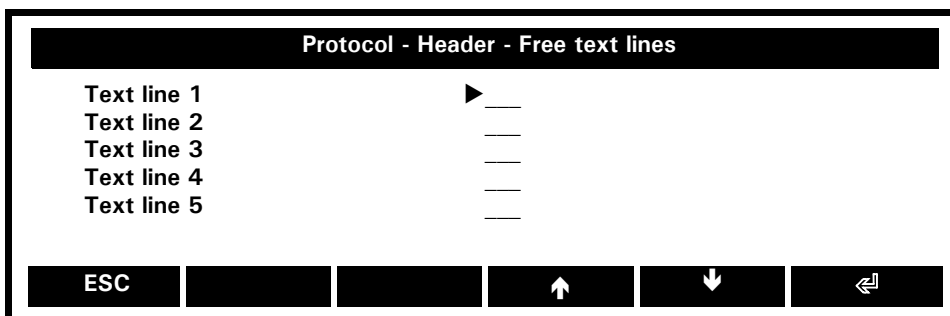
**12.3.1.1 Protocol - Header - Free text lines**

The free text of the header may act as heading or a title:

**Text line 1: \_\_\_\_\_**

Defines free text line 1, e.g.: „Precisa Gravimetrics AG“

**Text line 2: \_\_\_\_\_**

Defines free text line 2, e.g.: „Moosmattstrasse 32“





### 12.3.1.3 Protocol - Header/Footer - Position

At last there are a lot of ready-to-pick items which can be printed out in the protocol. Each position, if called up, offers its possibilities in a list box. Observe that the same item can be assigned to various positions at the same time, for example „Underline“ to the positions 2, 4 and 7. You have the possibility to set all position „off“ and to set the „default settings“.

Protocol - Header/Footer - Position		1/5
Position 1	▶ Device type	
Position 2	Device number	
Position 3	Device software	
Position 4	Off	
Position 5	Off	
Position 6	Off	
ESC   ←   →   ↑   ↓   ↵		

Protocol - Header/Footer - Position		5/5
All position OFF	▶ Set	
Set default settings	Set	
ESC   ←   →   ↑   ↓   ↵		

Some items can only be assigned either to the header or to the footer, others are assignable to both zones. The following table gives an overview of all items and their assign options:

How it Looks in the Printout (example)	Where Assignable	Name and Brief Information
***** Dryer *****	Header	<b>Application</b> <i>Shows the application „Dryer“</i>
Device           EM 120-HR	Header	<b>Device type</b> <i>Names the device type</i>
Device ID       AA1	Header	<b>Device ID</b> <i>Names the device identification, e.g. „AA1“, see chapter 13.6 "Configuration - Device settings"</i>
Device Number   4600031	Header	<b>Device number</b> <i>Names the number of the device</i>
Software         A40-0000 P03	Header	<b>Device software</b> <i>Names the software the device operates with</i>
Dryer top        Heating Unit	Header	<b>Dryer top type</b> <i>Names the type of the dryer top</i>
Dryer top no.   5483	Header	<b>Dryer top number</b> <i>Names the number of the dryer top</i>
Dryer top SW    C10-0000 P01	Header	<b>Dryer top software</b> <i>Names the software the dryer top</i>

## ■ 12 Context Menu

Date/Time 18.01.11 19:15:02	Header & Footer	<b>Date/Time</b> <i>Prints out the actual Date and Time, see chapter 13.7 "Configuration - Date/Time"</i>
User Administrator	Header & Footer	<b>User</b> <i>Names the user, learn more in chapter 14.1 "The Administrator Menu"</i>
Signature _____	Footer	<b>Signature</b> <i>Prints out a space holder for a handwritten signature</i>
„Free text“	Header & Footer	<b>Text line 1 ... 5</b> <i>Prints out the defined text of the corresponding chosen free text line (1 ... 5), see chapter 13.4.4.1 "Configuration - Protocol - Header - Free text lines"</i>
„Free HEX Line“	Header & Footer	<b>HEX Line 1 ... 4</b> <i>Prints out the content of the corresponding chosen free Hex line (1 ... 4), see chapter 13.4.4.2 "Configuration - Protocol - Header/Footer - Free HEX lines"</i>
-----	Header & Footer	<b>Underline</b> <i>Prints out an underline</i>
„Empty line“	Header & Footer	<b>Linefeed</b> <i>Prints an empty line</i>
„Form feed“	Footer	<b>Formfeed</b> <i>Executes a form feed command</i>

### 12.3.2 Proctocol - Method

Define the method information on the protocol

**Dryer - Protocol - Method**

<b>Method</b>	<b>► On</b>
<b>Position</b>	<b>Define</b>

ESC
↑
↓
↩

**Protocol - Method -Position** 1/8

<b>Position 1</b>	<b>► Name</b>
<b>Position 2</b>	<b>Number</b>
<b>Position 3</b>	<b>Heating mode I1</b>
<b>Position 4</b>	<b>Set Temperature I1</b>
<b>Position 5</b>	<b>Stop time I1</b>
<b>Position 6</b>	<b>Stop mode I1</b>

ESC
←
→
↑
↓
↩

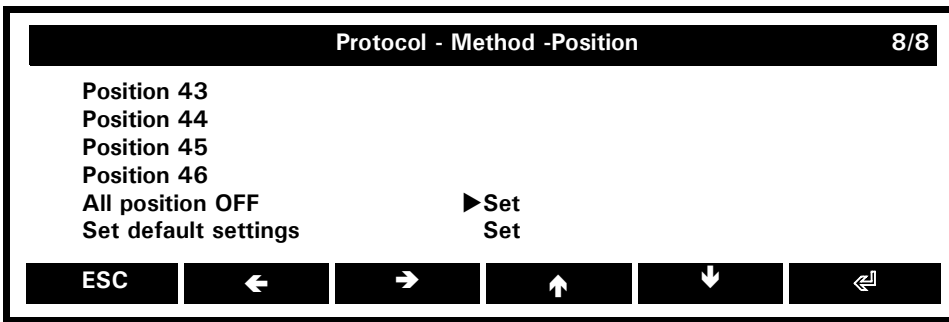

How it Looks in the Printout (example)	Name and Brief Information
Milk	<b>Name</b> <i>Names the method name</i>
Number            1	<b>Number</b> <i>Names the method number</i>
Interval           1	<b>Interval quantity</b> <i>Number of intervals</i>
Device Number   4600031	<b>Device Number</b>
Refill             on	<b>Refill</b>
Autostart         off	<b>Autostart</b>
Quickstart       off	<b>Quickstart</b>
Last change      18.01.11  19:15:02	<b>Last change</b> <i>Date and time of last method change</i>
Interval 1/2/3	<b>Interval no. 1/2/3</b> <i>Names the interval number</i>
Heating mode     Standard	<b>Heating mode I1,I2,I3</b> <i>Heating mode of interval</i>
Temperature      105 C	<b>Set Temperature I1/I2/I3</b> <i>Drying temperatur of interval</i>
Stop mode         2D/60s	<b>Stop mode I1/I2/I3</b> <i>stop mode of interval</i>
Standby temp     50 °C	<b>Standby temperature</b>
Delay time        1:00 min	<b>Delay time I1/I2/I3</b> <i>delay time of interval</i>
Stop time         10:00 min	<b>Stop time I1/I2/I3</b> <i>Prints out an underline</i>
Unit               Residual %	<b>Unit I1/I2/I3</b> <i>Prints the unit of interval</i>
Corr factor       1.100	<b>Correction fact. I1/I2/I3</b> <i>Corrcetion factor of result in interval</i>
-----	<b>Underline</b> <i>Prints out an underline</i>
„Empty line“	<b>Linefeed</b> <i>Prints an empty line</i>

■ 12 Context Menu

12.3.3 Protocol - Measurement

Define the measurement information on the protocol

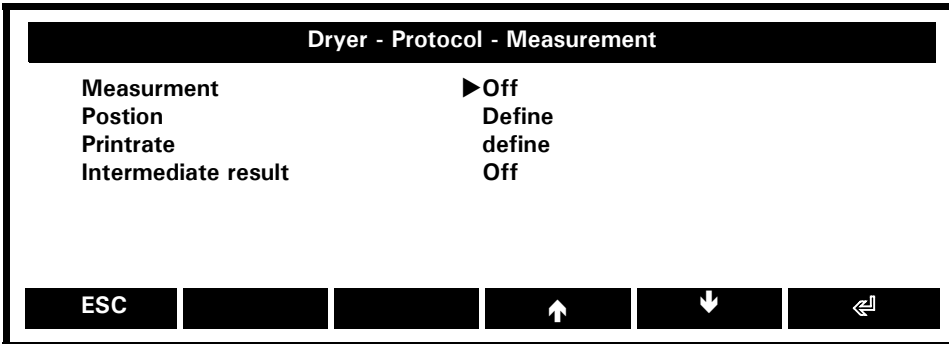

**Measurement: On, Off**

*Prints results during analysis (-> Printrate)*

**Position: define**

*Prints results during analysis (-> Printrate)*

**Printrate: define**

*Defines the printrate*

**Intermediate result: On, Off**

*Prints results for all defined heating interval*

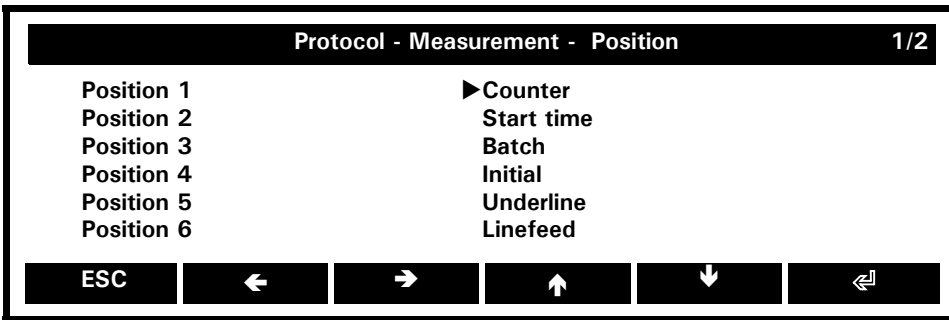

How it Looks in the Printout (example)	Name and Brief Information
Start time      21.02.11/12:20:10	<b>Start time</b> <i>Start date and time</i>
Measurement    1	<b>Counter</b> <i>number of measurements</i>
Batch            A1	<b>Batch</b> <i>Names the batch</i>
Initial         2.325 g	<b>Initial</b>
-----	<b>Underline</b> <i>Prints out an underline</i>
„Empty line“	<b>Linefeed</b> <i>Prints an empty line</i>

12.3.3.1 Protocol -Measurement - Printrate

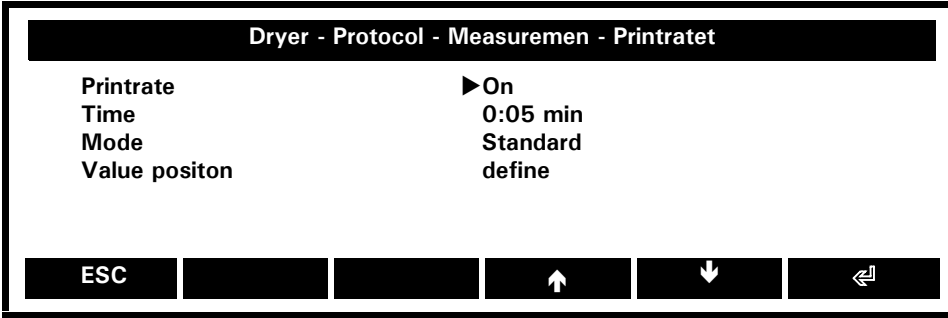

**Printrate:** Off, On

*Prints results on timebase*

**Time:** 0:05

*Define the timebase*

**Mode:** Standard, Tabulator

*Tabulator (for data export): values are separated by tabulators*

**Value position:** Define

*Defines the measurement information on the print out*

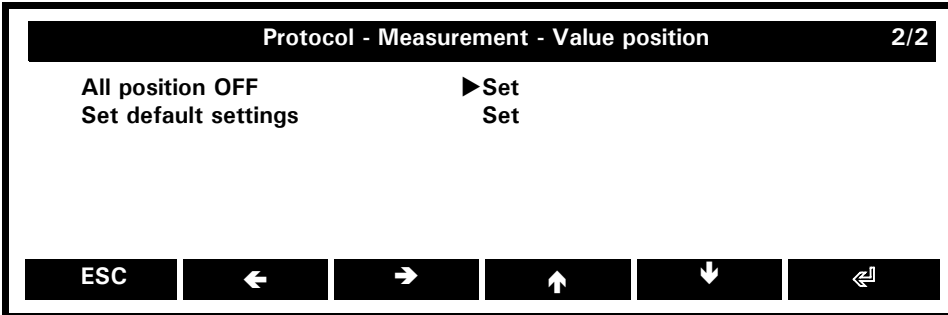
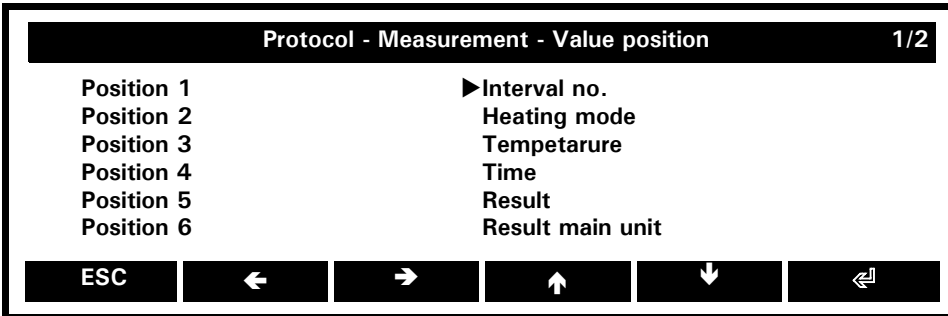

**How it Looks in the Printout (example)**

Measurement all postion on:

1	B	77 C	0:00 min	100.00 % D	2.505 g
1	B	78 C	0:05 min	99.96 % D	2.504 g
1	B	88 C	0:10 min	99.82 % D	2.501 g
1	B	99 C	0:15 min	99.74 % D	2.499 g
1	B	108 C	0:20 min	99.63 % D	2.496 g



Corr factor 1 1.600	<b>Corr factor</b> <b>Corr factor 1/2/3</b> <i>Correction factor for result</i>
Correction 1 159.79 % D	<b>Correction</b> <b>Correction 1/2/3</b> <i>Corrected result</i>
LastWeight Cal 21.01.11/06:04:44	<b>LastWeight Cal</b>
Last Temp. Cal 22.01.11/07:12:05	<b>Last Temp. Cal</b>
	<b>ID - ID1/2/3/4/5/6</b> <i>Prints out the defined IDs</i>
„Free text“	<b>Text line 1 ... 5</b> <i>Prints out the defined text of the corresponding chosen free text line (1 ... 5)</i>
„Free HEX Line“	<b>HEX Line 1 ... 4</b> <i>Prints out the content of the corresponding chosen free Hex line (1 ... 4)</i>

## 12.4 Screen settings

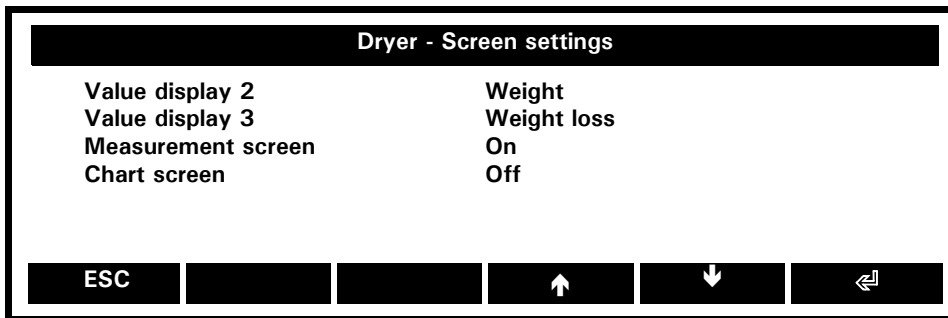

**Value display 2:** Off, **Weight**, Weight loss, Residual %, Loss % ...  
*Define the second displayed result value*

**Value display 3:** Off, **Weight**, **Weight loss**, Residual %, Loss % ...  
*Define the third displayed result value*

**Measurement Screen:** On, Off

*If activated the measurement screen can be chosen during the analysis by pressing the «ROTATE» key.*

**Chart Screen:** On, Off

*If activated the chart screen can be chosen during the analysis by pressing the «ROTATE» key*

## 12.5 Identification

You have the possibility to define up to 6 identifications. Before the analysis, you can enter the sample information e.g. Article, Art. no., Lot..... Identifications can be shown in the info fields and printed in the protocol. Activated IDs are marked with an asterix

Define the identifications in Dryer - identification. Assigne for each identification a function key. (see below)



■ 12 Context Menu

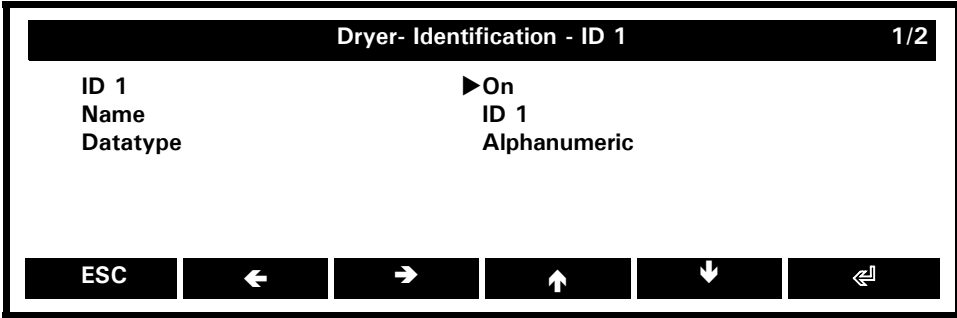
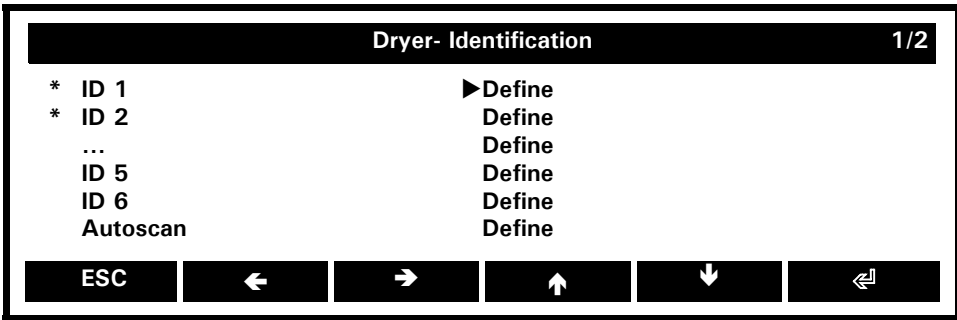

ID: Off, On

Name:

Enter the name of the identification: e.g. article, lot...

Datatype: alphanumeric, numeric

Choose the datatyp

## 12.6 Soft key

A soft key is a soft-coded key, a button, located alongside the display, which performs a function displayed near or right above it in the function bar at that moment. (In opposition to that, a hard key is a hard-coded key, which performs just its firmly assigned function, e.g. «ON/OFF».) You may assign a choice of various functions to the soft keys. If you assign more than 6 functions, a function {←} or {→} is displayed to switch from the current selection to the next.

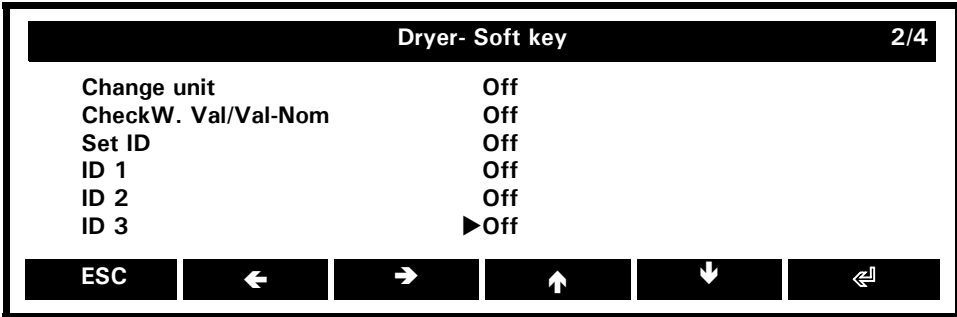
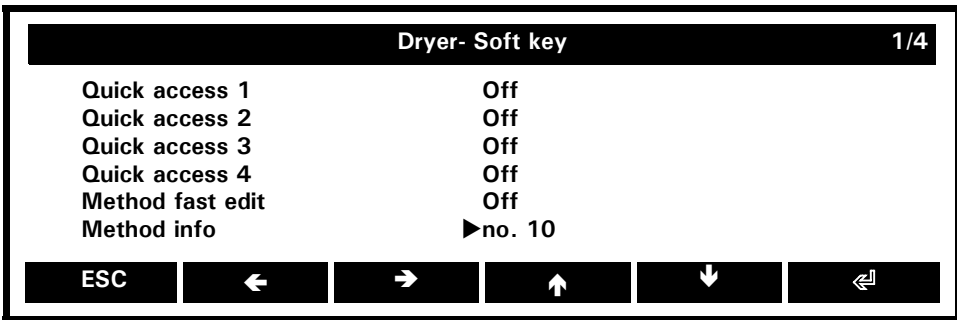

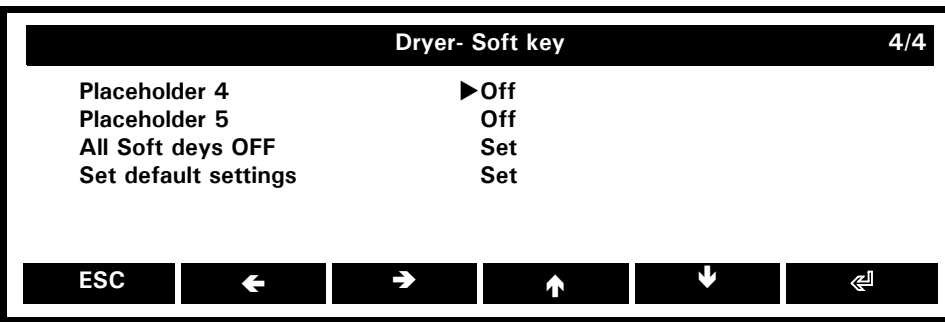
**Quick access 1-4**

Assine the methods you have chosen for quick access in „method managemen“ to the soft keys.

**Method fast edit**

Direct access to edit the actual method. No „save as“ possible with fast edit.

**Method info**

Direct access to the method info of the actual method.

**Change Unit**

Allows you to change the unit of the main display during analysis an after the run without affecting the print outs of the result (which are defined in the method and the protocol settings)

**CheckW. Val/Val-Nom**

Only with checkweigher. Main display of weighing in changes to the difference to the nominal weight set in check weigher. The difference value is marked with a circle.

**Set ID**

All IDs activated in context menu „Identification“ are listed and opened to enter the actual identifications.

**ID1 , ID2 -ID6**

The chosen ID activated in context menu „Identification“ is opened to enter the actual identification.

**Placeholder**

„No function“; shifts the following soft key one position to the right.

## 12.7 Info Fields

:Choose information to be displayed on the infofield.

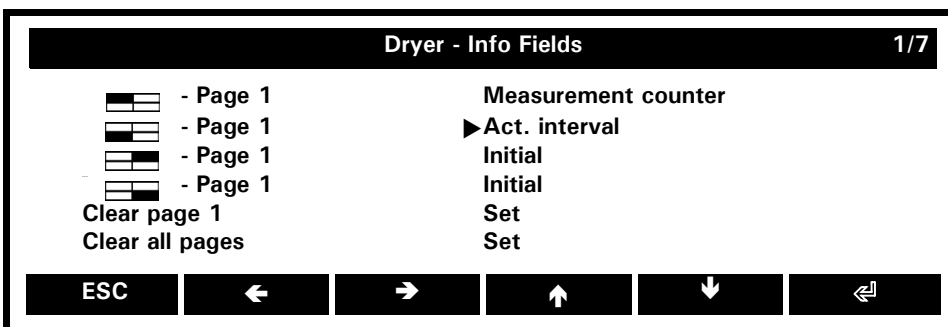

**By default assigned and available (off) specific info fields:**

**Measurement counter**

number of measurement (per method, per batch)

**Act. interval**

activ interval

**Initial (1/2/3)**

initial weights of interval resp. the base for calculation

**Result (1/2/3)**

result of interval

**Corr factor (1/2/3)**

Correction factor of interval

■ *12 Context Menu*

**Correction (1/2/3)**

*Corrected result of interval*

**Duration (1/2/3)**

*Duration of interval*

**Tare**

**Net**

**Gross**

**CheckW.TU**

*under limit*

**CheckW.TO**

*over limit*

**CheckW.Nominal**

*Nominal weight*

**ID- ID 1-6**

*Identification*

## 13 The Configuration

This section explains the structure of the configuration menu and its functions. The basic adjustment of the moisture analyser is defined in the configuration.

### ! NOTE

Angle quoted menu items do not appear, unless in cooperation with particular settings.

### 13.1 Setup Configuration Menu

#### 13.1.1 The Setup Configuration Menu

- Hold «MENU» to switch the home screen.
- Keep pressing {➔} until the settings menu is selected.
- Press {▲} beneath the configuration-icon to switch the configuration menu.

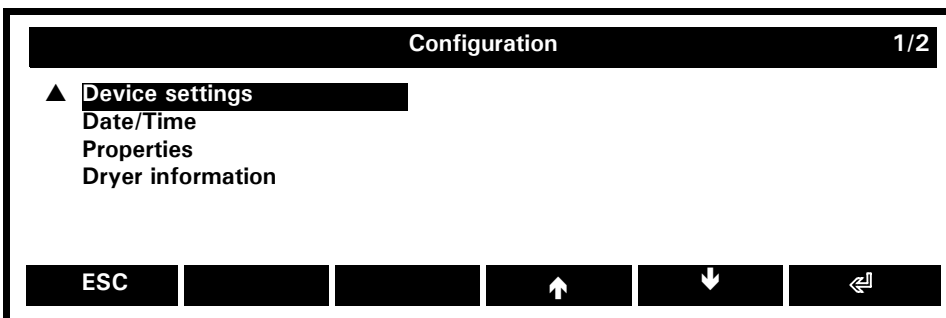
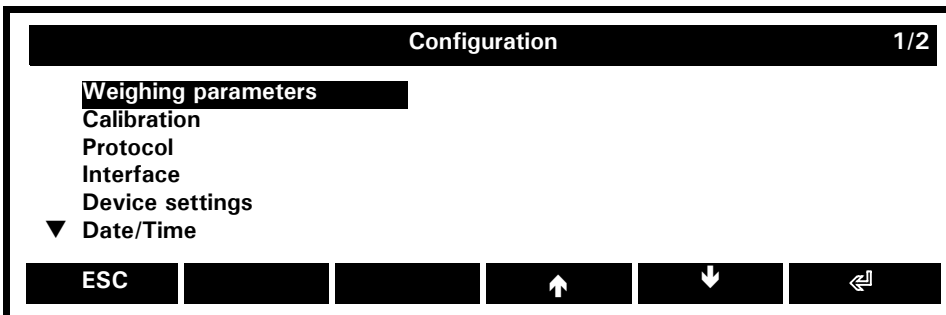

#### **Weighing parameters:**

*General settings/parameters for the weighing system*

#### **Calibration:**

*General settings for the calibration*

#### **Protocol:**

*General settings for the protocol/printout*

#### **Interface:**

*General settings for the RS232/V24 interface to communicate with peripheral devices*

#### **Device settings:**

*General settings for the look-and-feel*

#### **Date/Time:**

*General settings for the date and time*

#### **[Slide in module]**

*(only available if the dryer is equipped with a slide-in module)*

*General setting for the slide-in module. For details refer to its operating instruction*

#### **Properties:**

*Display and printout of all configuration settings*

#### **Dryer information**

*Hardware and Software information*



**[Weight ID:]** \_\_\_\_\_

*(only available in Calibration Mode External Def.-Weight)*

*Sets an alphanumeric identification to the external calibration weight*

**[Automatic Mode:]** Time & Temperature, Temperature, Time

*(only available in Calibration Mode Automatic)*

- Automatic calibration on time and temperature
- Automatic calibration on temperature
- Automatic calibration on time

**[Temperature:]** 2 C

*(only available in Calibration Mode Automatic)*

*Defines how much the temperature has to change to start the automatic calibration. Pre-set is a temperature change of 2. The unit is about degree Celsius.*

**[Time:]** 06:00:00

*(only available in Calibration Mode Automatic)*

*Defines the time of day on which to start the automatic-calibration*

**Protocol:** On, Off

*Executes, after a calibration, a printout of the calibration protocol*

## 13.4 Configuration - Protocol

### ! NOTE

The protocol set in configuration regards only the weighing values.

The protocol of analysis work with the protocol setting in the context menu (see 12.3 "Protocol")

Just pressing «**PRINT**» transmits the current measuring result via interface to the peripherals. Setting up the protocol, you can

- define under what conditions this has to happen
- define the format of the value (measuring result) in the printout
- choose various additional information to be printed out.

The main screen to setup the protocol:

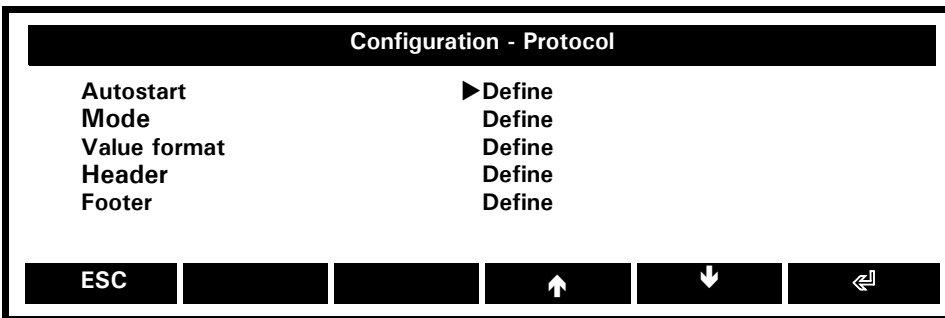

**Autostart:** Define

*Defines the automatic start of the printout after the moisture analyser has been switched on. An '\*' is displayed if the autostart is enabled*

**Mode:** Define

*Defines the mode of the printout, e.g. stable or after a loadchange, and so on*

**Value format:** Define

*Defines the format of the weight value in the printout*

**Header:** Define

*Defines the format of a header in the printout. An '\*' is displayed if the Header is enabled*

**Footer:** Define

*Defines the format of a footer in the printout. An '\*' is displayed if the Footer is activated*







## ■ 13 The Configuration

**Sign:** -xxx.yy, -\_\_xxx.yy, -/+xxx.yy, -/+\_\_xxx.yy

- Left oriented, with negative sign only

- Right oriented, with negative sign only

- Left oriented, with negative and positive sign

- Right oriented, with negative and positive sign

**Length: 9**

Length of value, e.g: 9 digits

**Decimals: 0**

Decimal places of value, e.g: 0 decimals places

**Decimal separator: Point**

Point or comma

**Unit: 5**

Length of unit, e.g: 5 characters

**Overload text: OL**

Text to indicate an overload condition, e.g: „OL“

**Underload text: OL**

Text to indicate an underload condition, e.g: „UL“

### 13.4.3.3 Configuration - Protocol - Value format - Position

This setting is only available if the value format is set to „user defined“, see chapter 13.4.3 "Configuration - Protocol - Value format".

In a printout, the measuring result, that in the menu is called „Value“, fills one line. The measuring result doesn't consist just of its numeric value, e.g.: „123.456“, but of up to 7 positions:

Configuration - Protocol - Value format - Position		1/2
Indicator *,o	▶no. 1	
Indicator <,>	no. 2	
Value	no. 3	
Unit	no. 5	
Spacing 1	no. 4	
Spacing 2	Off	

ESC ← → ↑ ↓ ↵

Configuration - Protocol - Value format - Position		2/2
Spacing 3	Off	

ESC ← → ↑ ↓ ↵

**Indicator \*,o:** Off, no. 1, no. 2, no. 3, no. 4, no. 5

Position of Indicator \*,o, e.g.: 1st position

**Indicator <,>:** Off, no. 1, no. 2, no. 3, no. 4, no. 5

Position of space holder 2, e.g: not used

**Value:** Off, no. 1, no. 2, no. 3, no. 4, no. 5

Position of value, e.g: 1st position

**Unit:** Off, no. 1, no. 2, no. 3, no. 4, no. 5

Position of unit, e.g: 3rd position

**Spacing 1:** Off, no. 1, no. 2, no. 3, no. 4, no. 5

Position of space holder 1, e.g: 2nd position

**Spacing 2:** Off, no. 1, no. 2, no. 3, no. 4, no. 5

Position of space holder 2, e.g: not used

**Spacing 3: Off**, no. 1, no. 2, no. 3, no. 4, no. 5

*Position of space holder 3, e.g: not used*

The following table is to illustrate the resulting printout at various position settings for the value format, without the indicators „\*,o“ and „<, >“, which appear under particular conditions only:

Pos. no 1	Pos. no 2	Pos. no 3	Pos. no 4	Pos. no 5	Printout
Value	Space 1	Unit	not assigned	not assigned	+ 123.456_g
Space 1	Value	Space 2	Unit	Space 3	_ + 123.456_g_
Unit	Space 1	Value	not assigned	not assigned	g_ + 123.456
Space 1	Value	Space 2	Unit	not assigned	_ + 123.456_g

### 13.4.4 Configuration - Protocol - Header/Footer (common items)

As the menu header and the footer menus differ just in the item „Position“, both are treated in this chapter.

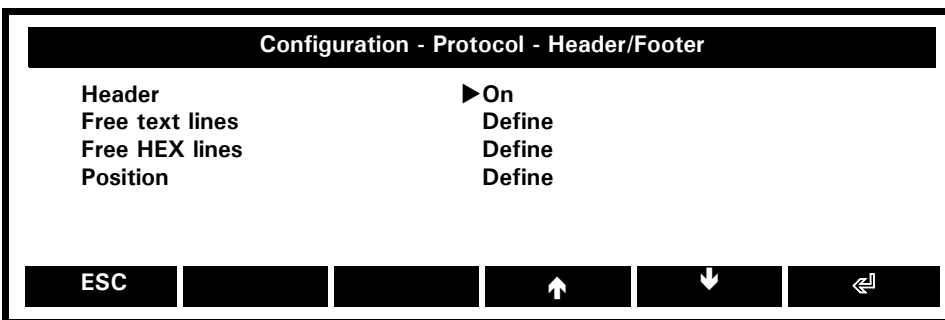

**Header/Footer:** On, Off

*Header/Footer is enabled in printout*

**Free text lines:** Define

*Defines text lines for header/footer, see chapter 13.4.4.1 "Configuration - Protocol - Header - Free text lines"*

**Free Hex lines:** Define

*Defines hexadecimal output for header/footer, see chapter 13.4.4.2 "Configuration - Protocol - Header/Footer - Free HEX lines"*

**Position:** Define

*Defines positions in header/footer*

#### 13.4.4.1 Configuration - Protocol - Header - Free text lines

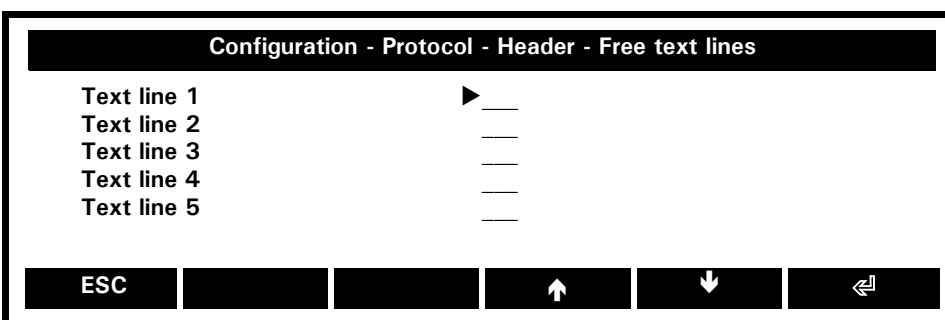

The free text of the header may act as heading or a title:

**Text line 1:** \_\_\_\_

*Defines free text line 1, e.g.: „Precisa Gravimetrics AG“*

**Text line 2:** \_\_\_\_

*Defines free text line 2, e.g.: „Moosmattstrasse 32“*

**Text line 3:** \_\_\_\_

*Defines free text line 3, e.g.: „CH-8953 Dietikon“*

**Text line 4:** \_\_\_\_

*Defines free text line 4, e.g.: „SWITZERLAND“*



the same time, for example „Underline“ to the positions 2, 4 and 7.

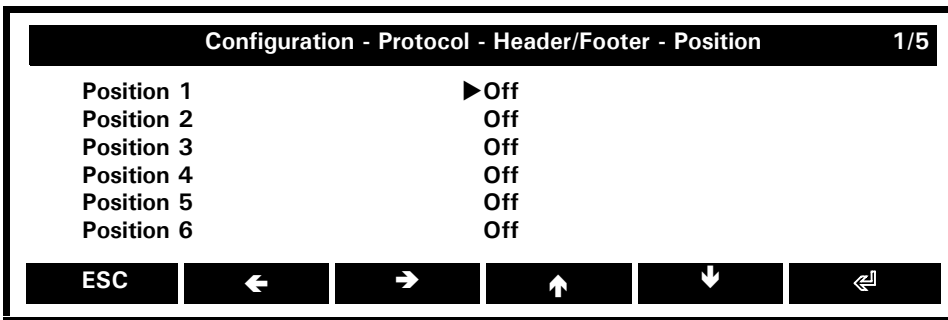

Some items can only be assigned either to the header or to the footer, others are assignable to both zones. The following table gives an overview of all items and their assign options:

How it Looks in the Printout (example)	Where Assignable	Name and Brief Information
***** Dryer *****	Header	<b>Application</b> <i>Shows the application „Dryer“</i>
Device EM 120-HR	Header	<b>Device type</b> <i>Names the device type</i>
Device ID AA1	Header	<b>Device ID</b> <i>Names the device identification, e.g. „AA1“, see chapter 13.6 "Configuration - Device settings"</i>
Device Number 4600031	Header	<b>Device number</b> <i>Names the number of the device</i>
Software A00-0000 P03	Header	<b>Device software</b> <i>Names the software the device operates with</i>
18.01.09 19:15:02	Header & Footer	<b>Date/Time</b> <i>Prints out the actual Date and Time, see chapter 13.7 "Configuration - Date/Time"</i>
User Administrator	Header & Footer	<b>User</b> <i>Names the user, learn more in chapter 14.1 "The Administrator Menu"</i>
Signature _____	Footer	<b>Signature</b> <i>Prints out a space holder for a handwritten signature</i>
„Free text“	Header & Footer	<b>Text line 1 ... 5</b> <i>Prints out the defined text of the corresponding chosen free text line (1 ... 5), see chapter 13.4.4.1 "Configuration - Protocol - Header - Free text lines"</i>

## ■ 13 The Configuration

„Free HEX Line“	Header & Footer	<b>HEX Line 1 ... 4</b> <i>Prints out the content of the corresponding chosen free Hex line (1 ... 4), see chapter 13.4.4.2 "Configuration - Protocol - Header/Footer - Free HEX lines"</i>
-----	Header & Footer	<b>Underline</b> <i>Prints out an underline</i>
„Empty line“	Header & Footer	<b>Linefeed</b> <i>Prints an empty line</i>
„Form feed“	Footer	<b>Formfeed</b> <i>Executes a form feed command</i>

### 13.5 Configuration - Interface

**Configuration - Interface**

<b>Baudrate</b>	▶ 9600
<b>Parity</b>	7 Even 1
<b>Handshake</b>	None
<b>PC direct mode</b>	Off

ESC
 
 
↑
↓
↵

**Baudrate:** 300, 600, 1200, 2400, 4800, **9600**, 19200, 38400, 57600

*Selects a baud rate for the RS232/V24 interface in order to match with the interface of a connected peripheral device, learn more in chapter 15 "Data Transfer"*

**Parity:** 7 Even 1, 7 Odd 1, 7 None 2, 8 None 1

*Selects a parity for the RS232/V24 interface in order to match with the interface of a connected peripheral device, learn more in chapter 15 "Data Transfer"*

**Handshake:** None, XOn / XOff, Hardware

*Selects the handshake for the RS232/V24 interface in order to match with the interface of a connected peripheral device, learn more in chapter 15 "Data Transfer"*

**PC direct mode:** On, **Off**

*Enables/disables the PC direct mode, learn more in chapter 15 "Data Transfer"*

### 13.6 Configuration - Device settings

**Configuration - Device settings** 1/2

<b>Device ID</b>	▶ <u>  </u>
<b>Language</b>	English
<b>Key tone</b>	On
<b>Advice tone</b>	On
<b>Display contrast</b>	Medium
<b>Display backlight</b>	20%
<b>Headline</b>	Device info
<b>Home</b>	Applications

ESC
←
→
↑
↓
↵

**Device ID:**   

*Allows to put in an alpha-numerical identification (max. 20 characters) which is also displayed during the start-up sequence, when the moisture analyser is switched on*

**Language: English, Deutsch, Française**

*Selects a language*

**Key tone: On, Off**

*Activates the key tone*

**Advice tone: On, Off**

*Activates an sound for events like end of measurement*

**Display contrast: low, medium, high**

*Adjusts the level of the display contrast*

**Display backlight: 20%, 40%, 60%, 80%, 100%**

*Adjusts the level of the display backlight*

**Headline: Device info, Date/Time**

- *The headline displays the running application with weighing range and readability*

- *The headline displays the running application and the system clock with date & time*

**Home: Applications, User**

- *The menu „Applications“ is selected after acceding to the home screen*

- *The menu „User“ is selected after acceding to the home screen*

## 13.7 Configuration - Date/Time

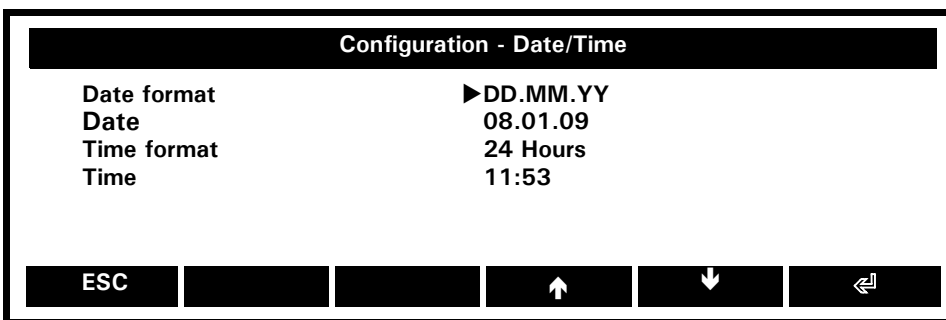

**Date format: DD.MM.YY, DD.MM.YYYY, MM.DD.YY, MM.DD.YYYY**

*Selects the date format*

**Date: 26.12.08**

*Sets the clock date*



### NOTE

If a power failure occurs, the timer continues running. If this does not happen, this indicates that the instrument's backup battery has expired and has to be replaced by the Customer Service.

## 13.8 Configuration - Properties

Select this menu item to display all settings of the configuration in an info window. To printout the content of this info window, press «**PRINT**», see also chapter 10.4 "The Info window".

# 14 The Administrator and the User Profiles

It is possible to save one administrator profile and 7 different user profiles. A profile consists of all the configuration and application settings.

## 14.1 The Administrator Menu

- Hold «MENU»
- Keep pressing {→} until „Settings“ in the headline is selected
- Press {▲} beneath the Administrator icon

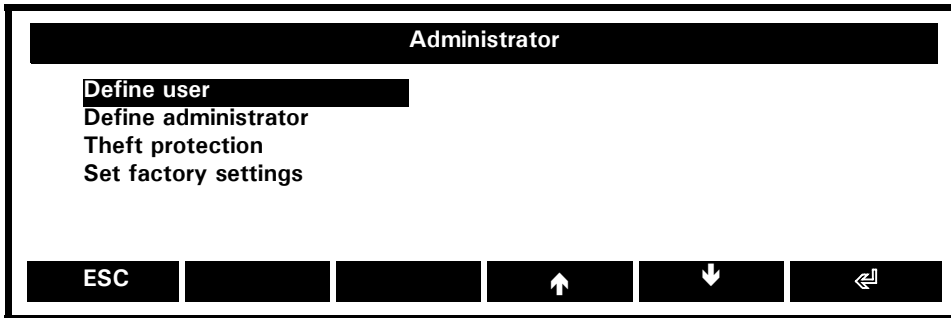

**Define user:**

*Defines up to 7 user profiles of the moisture analyser, see chapter 14.1.1 "Administrator - Define user" below*

**Define Administrator:**

*Defines the administrator profile*

**Theft protection:**

*Sets up the theft protection with password*

**Set factory settings:**

*Sets all configuration and application settings to the default settings, see chapter 14.2 "Resetting to the Factory Configuration" above*

	<b>NOTE</b>
Setting the factory settings as administrator clears and disables also all user profiles!	

### 14.1.1 Administrator - Define user

This menu allows the administrator to manage the entire user list.

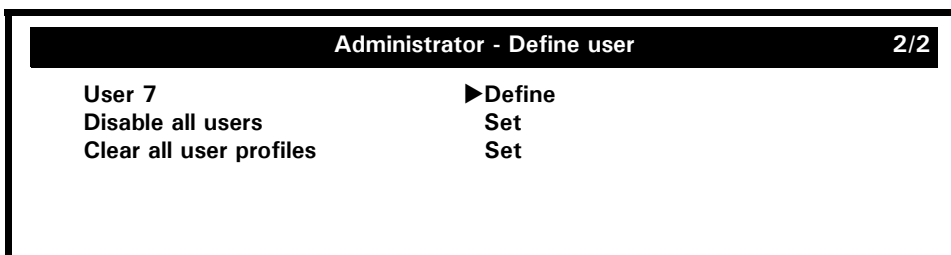
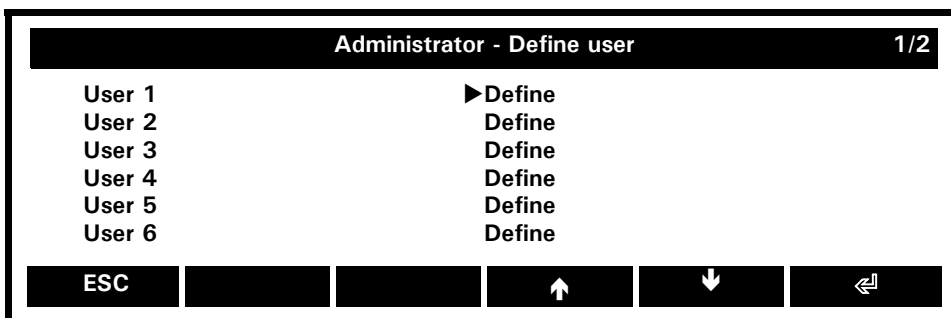



**User 1/2/3/4/5/6/7: Define**  
*Defines the user 1/2/3/4/5/6/7*

**Disable all users: Set**  
*Disables all users*

**Clear all user profiles: Set**  
*Clears all user profiles*

**14.1.1.1 Administrator - Define user - User 1/2/3/4/5/6/7**

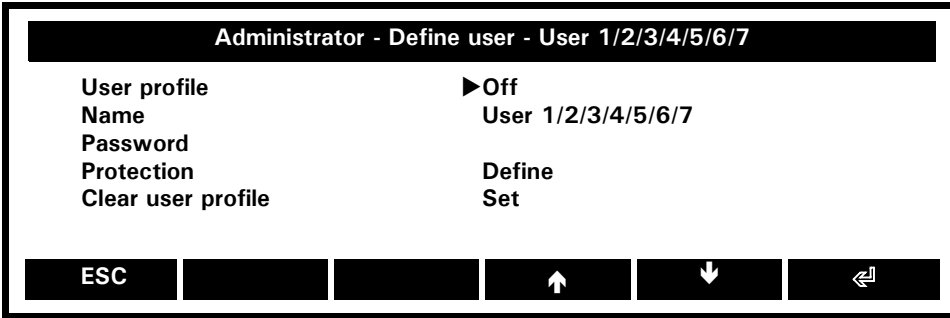

**User 1/2/3/4/5/6/7: On, Off**  
*Enables/disables the user 1/2/3/4/5/6/7*

**Name: User 1/2/3/4/5/6/7**  
*Names the user 1/2/3/4/5/6/7*

**Password:**  
*Enter password*

**Protection: Define**

**Clear user profile: Set**  
*Clears the selected user profile 1/2/3/4/5/6/7*

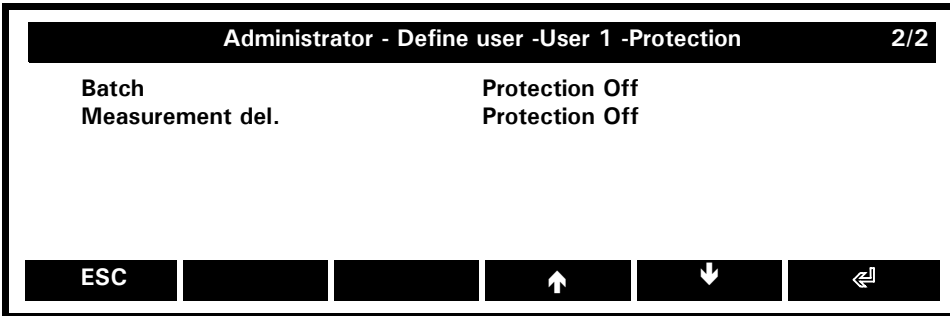
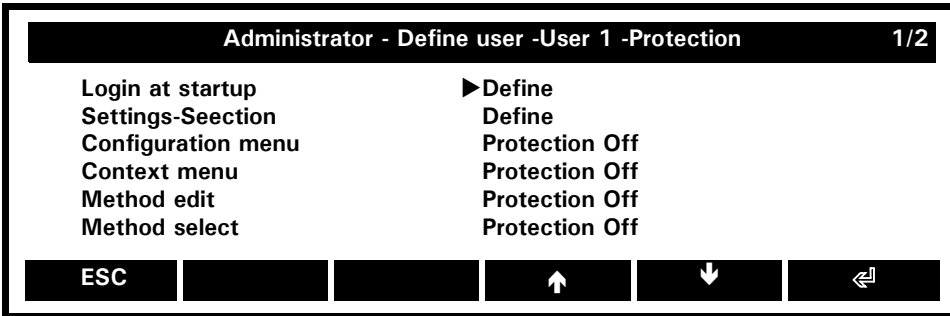

**Login at startup: On, Off**  
*Login password protected*

**Setting-selection: On, Off**  
*Access to the setting selection*





up to six-digit numerical code:

- If the anti-theft code is deactivated, the instrument can be re-started and operated after a power outage without having to enter a code.
- If the anti-theft code is activated, the instrument requires the code to be input after each power outage.
- If the code is entered incorrectly, the instrument is locked.
- If the instrument is locked, it must first be disconnected from the power supply, then reconnected and unlocked by entering the correct code.
- After seven consecutive incorrect entries, the display reads „NO ACCESS, CALL SERVICE“. In this case only a service engineer can unlock the instrument again.



#### NOTE

**Neither the theft protection status nor the anti-theft code changes by resetting the moisture analyser to the factory settings.**

## 14.2 Resetting to the Factory Configuration

As administrator you can reset the moisture analyser to the basic configuration programmed in the factory at any time. Thereby all configuration and application settings will be set to the default settings.

- Hold «MENU»
- Keep pressing {→} until „Settings“ in the headline is selected
- Press {▲} beneath the Administrator icon
- Keep pressing {↓} until the menu item „Set factory settings“ is selected and
- Press {↵} to confirm your selection
- Affirm the question „Set factory settings?“ by pressing {Yes}

# 15 Data Transfer

For data-transfers to peripheral devices, the dryer is equipped with an RS232/V24-interface.

Before the data-transfer, the RS232 interface must be matched with the one in the peripheral device in the dryer configuration menu (see chapter 13.5 "Configuration - Interface").

• **Handshake**

The handshake is set to „NO“ (none) at the factory. It can be set to software handshake „XON-XOFF“, or to hardware handshake „HARDWARE“.

• **Baud rate**

Possible baud rates: 300, 600, 1200, 2400, 4800, 9600, 19200, 38400, 57600 baud.

• **Parity**

Possible parity: 7 even 1 stop, 7 odd 1 stop, 7 no 2 stop, 8 no 1 stop, 8 even 1 stop, 8 odd 1 stop.

Pos.	0	1	2	3	4	5	6	7	8	9	10
7-even-1	SB	1.DA	2.DA	3.DA	4.DA	5.DA	6.DA	7.DA	PB	SP	-
7-odd-1	SB	1.DA	2.DA	3.DA	4.DA	5.DA	6.DA	7.DA	PB	SP	-
7-no-2	SB	1.DA	2.DA	3.DA	4.DA	5.DA	6.DA	7.DA	1.SP	2.SP	-
8-no-1	SB	1.DA	2.DA	3.DA	4.DA	5.DA	6.DA	7.DA	8.DA	SP	-
8-even-1	SB	1.DA	2.DA	3.DA	4.DA	5.DA	6.DA	7.DA	8.DA	PB	SP
8-odd-1	SB	1.DA	2.DA	3.DA	4.DA	5.DA	6.DA	7.DA	8.DA	PB	SP

SB: Start bit                      PB: Parity bit  
 DA: Data bit                      SP: Stop bit

• **Display**

S	D7	D6	D5	D4	D3	D2	D1	D0	U	U	U
---	----	----	----	----	----	----	----	----	---	---	---

The data-transfer takes place in ASCII code. The standard value format is as follows:

1	2	3	4	5	6	7	8	9	10	11	12	13	14	15	...	...	...
B	B	B	S	D7	D6	D5	D4	D3	D2	D1	DP	D0	B	U	...	CR	LF

- B**            Blank (space)
- S**            Sign (+, -, space)
- DP**          Decimal point
- D0...D7**    Digits
- U ...**        Unit (only if the weight is stable, otherwise no unit is send)
- CR**          Carriage return
- LF**          Line feed

<b>!</b> <b>NOTE</b>
Unused positions are filled with spaces. The decimal point DP can be between D0 and D7. If the value format is user defined the format is not as mentioned above!

## 15.1 Connection scheme

• **Standard duplex connection**

Dryer	DB 9 female	D25 / D9	Peripheral device
RS 232 out	2	3 / 2	RS 232 in
RS 232 in	3	2 / 3	RS 232 out
GND	5	7 / 5	GND

- Standard, duplex connection with additional hardware handshake in the peripheral device

Dryer	DB 9 female	D25 / D9	Peripheral device
RS 232 out	2 →	3 / 2	RS 232 in
RS 232 in	3 ←	2 / 3	RS 232 out
GND	5	7 / 5	GND
CTS	4 ←	20 / 4	DTR
DTR	8 →	5 / 8	CTS

## 15.2 Remote control-commands

Command	Function
ACKn	Acknowledge n=0 off; n = 1 on
CAL	Start calibration
N	Reset dryer
OFF	Switch off dryer
ON	Switch on dryer
PDT	Print out date and time
PRT	Start printing (Press « <b>PRINT</b> » key)
PST	Start print status of current user
Pn (ttt.t)	Set print mode for weight only n = 0 Individually print each value (unstable) n = 1 Individually print each value (stable) n = 2 Print after change of load n = 3 Print after each integration period n = 4 Print on time basis in s (ttt.t)
PWT ttt.t	Set print mode for weight and temperature Print on time basis in s ttt.t
R (nnn)	Heat to specific temperature n = 0 to switch off heating n = 40 to 230
SDTttmmjj hhmmss	Set date and time (German) (Tag, Monat, Jahr, Stunde, Minute, Sekunde)
SDTmmddy hhmmss	Set Date and Time (English) (Month, Day, Year, Hour, Minutes, Seconds)
T (ttt)	Tare or set tare to a specific value
ZERO	Zero balance (provided weight is stable and within the zero position range)



### NOTE

Each remote control-command must terminate with «CR» «LF». The commands are acknowledged if required.

### 15.2.1 Examples for the remote control

Input	Description of the function executed
R105	Heat to 105°C
R0	Switch off heating
T2.7	-2.7 g (Tare set to 2.7 g)
T1	-1.0 g (Tare set to 1.0 g)
T	Dryer is tared

## 16 Maintenance and Servicing

### 16.1 Utility program

- Hold the Tara-Key to open the utility program

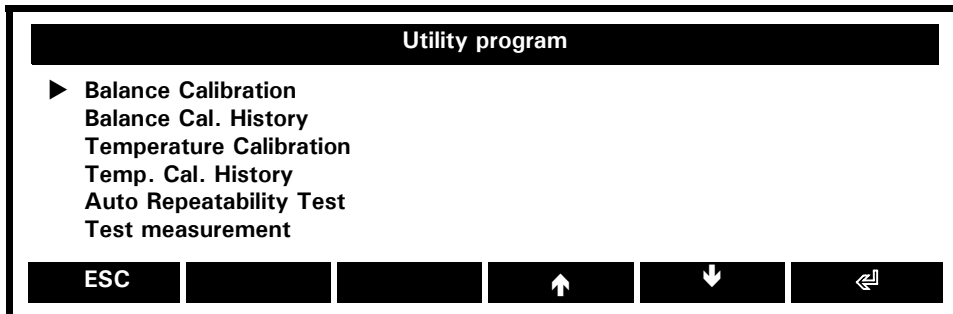

#### Balance Calibration

*Balance calibration as defined in the configuration menu*

#### Balance Cal. History

*You get the information on the last calibrations*

#### Temperature Calibration

*Two point temperature calibration*

#### Temp. Cal. History

*You get the information on the last calibrations*

#### Auto Repeatability Test

*Repeatability test with internal calibration weight.*

#### Test measurement

*Helps you to develop a method with the help of reference material.*

### 16.2 Calibration

The calibration of the balance is fixed in the Configuration menu ( 5.8 "Weight Calibration" and 13.3 "Configuration - Calibration").

Possible types of calibration:

- External calibration by means of ICM (Intelligent Calibration Mode)
- External calibration with freely selectable weight
- Internal calibration
- Automatic calibration

#### ! NOTE

The calibration can be interrupted at any time by pressing «ON/OFF».

To manually perform a calibration proceed as follows:

- Hold «0/T» until the utility program is shown.
- Select „Balance Calibration“ and press {←}





The calibration starts.

#### 16.2.1 External Calibration

Calibration weights in steps of 10 g can be used, where the calibration weight must correspond to the precision of the dryer.

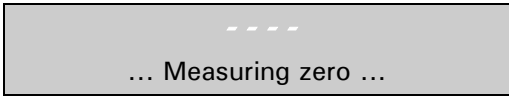
For external calibration with user-definable weight, „Calibration Mode = External“ must be selected in the Configuration menu (see chapter 13.3 "Configuration - Calibration").

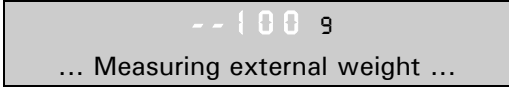
Start the calibration:

Display	Step
	The balance carries out a Zero measurement („---- g“ is shown flashing).
	After the zero measurement the display flashes with the recommended calibration weight.
	Place the calibration weight on the weighing pan. The display continuous to flash.
	Calibration is complete when the display stops flashing



### 16.2.2 External Calibration with Freely Selectable Weight

For external calibration with user-definable weight, „Calibration Mode = External Def.-Weight“ must be selected in the Configuration menu (see chapter 13.3 "Configuration - Calibration").

Then, the effective value of the calibration weight (Def.-Weight = n.nnn g) must be entered with up to ten-fold precision compared with the balance.

<b>! NOTE</b>
If calibration is carried out with the free weight, then only this weight may be used.

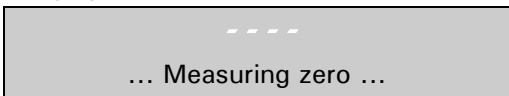
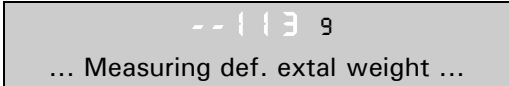
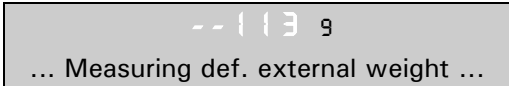
Start the calibration:

Display	Step
	The balance carries out a Zero measurement („---- g“ is shown flashing).
	After the zero measurement the display flashes with the recommended calibration weight.
	Place the calibration weight on the weighing pan. The display continuous to flash.
	Calibration is complete when the display stops flashing

### 16.2.3 Internal calibration

For internal calibration with the built-in calibration weight „Calibration Mode = Internal“ must be selected in the Configuration menu (see chapter 13.3 "Configuration - Calibration").

- Switch to the application „Weighing“.
- Press «0/T» until the calibration menu is shown.
- Select „Calibration“ and press {←}

The calibration starts and finishes after a certain period of time.

### 16.2.4 Automatic Calibration

For automatic calibration with the built-in calibration weight „Calibration Mode = Automatic“ must be selected in the Configuration menu (see chapter 13.3 "Configuration - Calibration").

The balance now calibrates itself automatically every 24 hours at the set time (e.g. 06:00:00 for 06.00 o'clock in the morning) and/or after each temperature change of the selecte value in degrees Celsius (e.g. 2

## ■ 16 Maintenance and Servicing

Temp for 2 degrees Celsius), depending on the definition in the Configuration menu.

### ! NOTE

For automatic calibration by time and by time/temp. the date and time of the moisture analyser must first be correctly set (see chapter 13.7 "Configuration - Date/Time").

Calibration can also be effected manually at any time when auto-calibration is activated.

Automatic calibration then takes place only if no weight has been placed on the pan for at least five minutes and the moisture analyser is not heating.

It is recommended that the time for auto-calibration be set outside the normal business hours (for example, in the early morning).

## 16.3 Temperature calibration

- Hold «0/T» until the utility program is shown.
- Select „Temperature Calibration“ and press {↵}

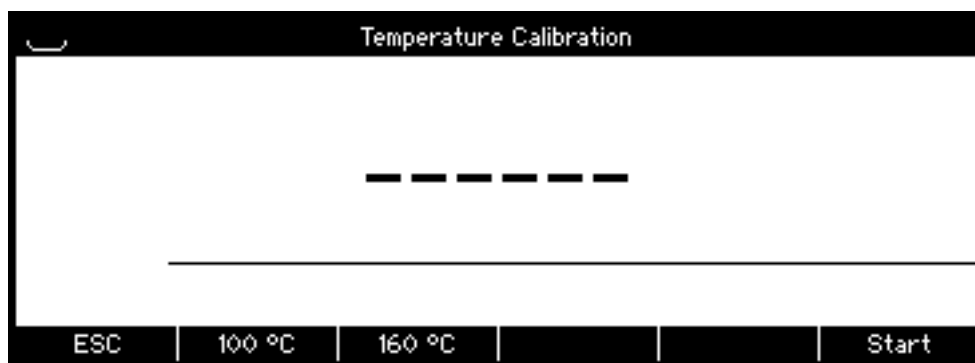

- The temperature calibration is done through two points. These temperatures can be changed by pressing the corresponding soft key.
- Enter the disc with the temperature probe.
- Start the calibration with Start

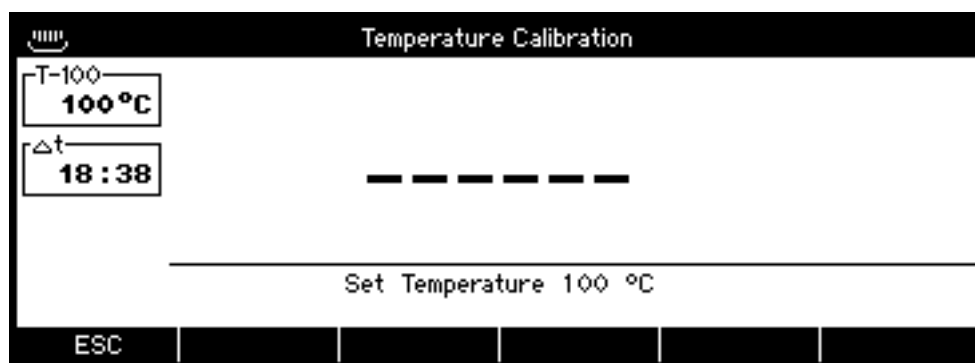

- The temperature is hold for 20 minutes.
- You are asked to enter the reference temperature

### ! NOTE

Do NOT activate with „enter“ (The field is already active for data input.)

„enter“ closes the input and the heating-up to the second calibration temperature starts.

- The moisture analyser is heating to the second temperature, which is held for 20 min.
- You are asked to enter the second reference temperature.
- At the end you are asked if the temperature adjustment has to be performed.

## 16.4 Test measurement

The method set in test measurement enables a fast method development.

- Hold «0/T» until the utility program is shown.
- Select „Test measurement“ and press {↵}

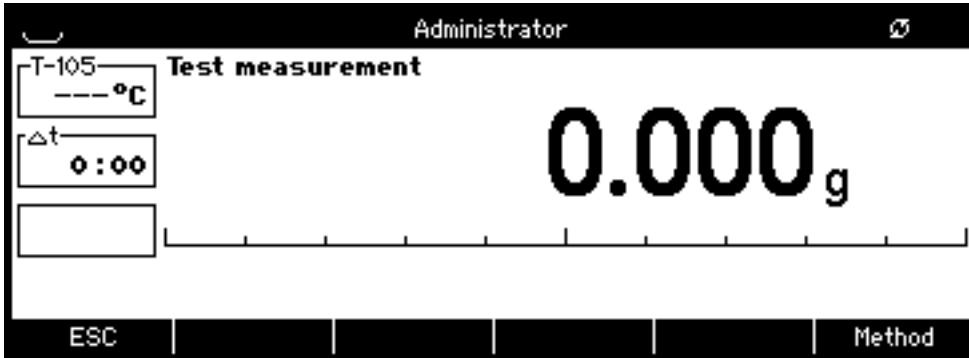

- Press the soft key Method to define temperature, heating mode, unit and resolution as in intervals of new method.
- You can define 5 different stop modes. For each of them the result will be printed (shown in the info window).
- Furthermore you can enter the reference result. The corresponding stop mode will be shown (only if result is reached with a stop mode nD/xxs)

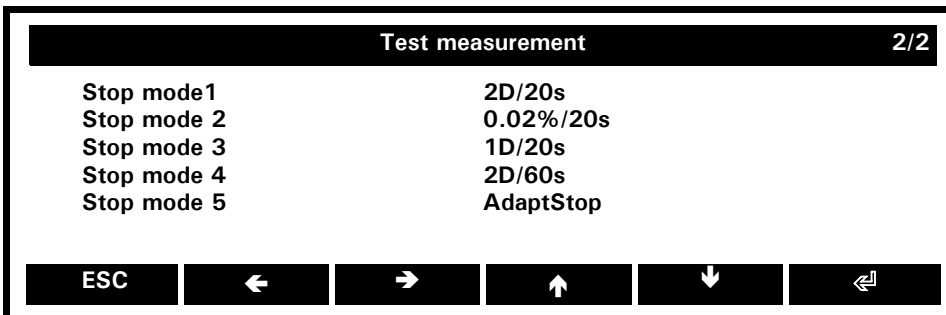
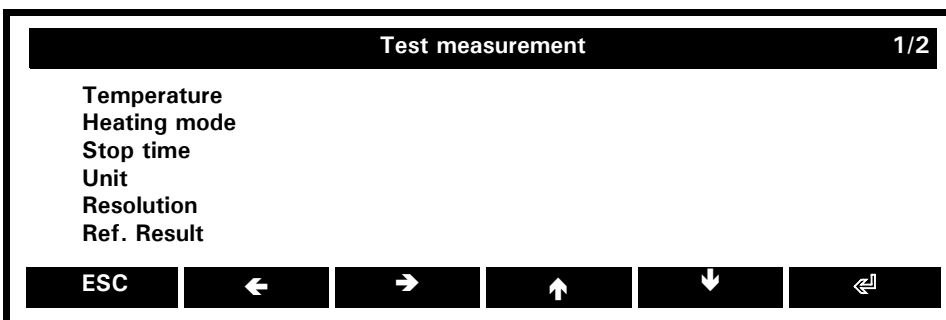

- Press ESC
- Tare, enter sample and start as used

## 16.5 Software Update

Our moisture analyser are instruments which are being continuously advanced and improved. For this reason, it is possible to update to the latest version of the instrument software via the internet.

In order to update your software, you need to download the Download Tool from the website and install it onto a PC with Windows.

The software for the moisture analyser can also be downloaded from the Downloads area on the website. This can then be loaded into the instrument with the aid of the download tool.



## 16.6 Cleaning

The moisture analyser must be treated carefully and cleaned regularly. It is a precision instrument.

### DANGER

For maintenance work, the moisture analyser must be separated from the power supply (remove power adaptor plug from socket). Also ensure that the moisture analyser cannot be reconnected to the power supply during the work by a third party.

Take care during cleaning that no liquid penetrates into the appliance. If liquid is spilt on the moisture analyser, the latter must immediately be disconnected from the electricity supply. The moisture analyser must only be used again after it has first been checked by a Service Engineer.

The connections on the rear of the appliance and the power adaptor must not come into contact with liquids.

Regularly dismantle the weighing pan and the weighing pan holder and remove any dirt or dust from under the weighing pan and on the moisture analyser housing with a soft brush or a soft, lint-free cloth, moistened with a mild soap solution.

The weighing pan and the holder can be cleaned under running water. Take care that both parts are completely dry before re-installing them on the moisture analyser.

### CAUTION

Never use solvents, acids, alkalis, paint thinners, scouring powders or other aggressive or corrosive chemicals for cleaning, since these substances attack the surfaces of the instrument housing and can cause damage.

The regular maintenance of the moisture analyser by your Service Representative will guarantee unlimited function and reliability over many years and will extend the lifespan of the moisture analyser.

## 16.7 Replacing the mains fuse

If the display remains dark after you switch on the instrument, this generally means that the instrument's fuse is faulty and has to be changed.

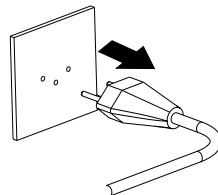

### DANGER

Unplug the instrument from the mains before replacing the fuses.

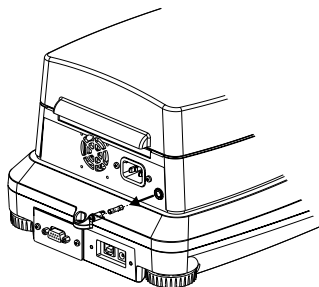

- Screw open the fuse holder on the back of the instrument using a screwdriver, screwing anticlockwise.
- Replace the faulty fuse:
  - 230 volt variant:  
**T 3.15 A, 230 V, 5x20 mm**
  - 115 volt variant:  
**T 6.3 A, 115 V, 5x20 mm**
- If the instrument still does not work after replacing the fuse, contact the Precisa Service Center.

### DANGER

Under no circumstances should you use other fuses or attempt to bridge the fuse.

## 16.8 Error Messages

The moisture analyser shows a description of the fault in the info-line.

### ! NOTE

If an error occurs without a description of the error in the info-line, the Customer Service must be called.

### 16.8.1 Notes on Correcting Faults

The following table shows faults and their possible causes. If you cannot clear the fault using the table, please contact the Customer Service..

Fault	Possible Cause
Weight display does not light	<ul style="list-style-type: none"> <li>• Moisture analyser not switched on</li> <li>• Connection to power adaptor is interrupted</li> <li>• Power supply has failed (interruption to current)</li> <li>• The power adaptor is defective</li> </ul>
“OL” is shown in display	<ul style="list-style-type: none"> <li>• The weight range has been exceeded (Observe information on the maximum weight range)</li> </ul>
“UL” is shown in display	<ul style="list-style-type: none"> <li>• The weight range is below the range of the moisture analyser (weighin pan or weighing pan holder missing)</li> </ul>
The weight display fluctuates continuously	<ul style="list-style-type: none"> <li>• The draft is too strong at the moisture analyser location</li> <li>• The moisture analyser support is vibrating or varying</li> <li>• The scale pan is touching a foreign body</li> <li>• The refresh rate chosen for is too fast</li> <li>• The material being weighed is absorbing moisture</li> <li>• The material being weighed is being blown away or is evaporating</li> <li>• Strong temperature variations in the material being weighed</li> </ul>
Results of weighing are clearly incorrect	<ul style="list-style-type: none"> <li>• The moisture analyser was not correctly tared</li> <li>• The moisture analyser is not correctly levelled</li> <li>• The calibration is no longer correct</li> <li>• There are strong temperature variations</li> </ul>
There is no display or only dashes	<ul style="list-style-type: none"> <li>• The stability control (Balance functions) is set too sensitively</li> <li>• The time selected for „FLOATINGDISPLAY“ is unsatisfactory</li> </ul>
Configuration menu cannot be changed	<ul style="list-style-type: none"> <li>• The password lock is activated in the configuration menu</li> </ul>
The display flashes continuously during calibration	<ul style="list-style-type: none"> <li>• The moisture analyser location is not stable enough (Interrupt calibration with «ON/OFF» and relocate the moisture analyser in a better position)</li> <li>• Use of an inprecise calibration weight (only applies to external calibration)</li> </ul>

# 17 Additional Information

## 17.1 Technical data

Spezifikation	EM 120-HR
Heat source, heater type	Halogen / Infra-red / Dark Radiator
Weighing range [g] ; Readability [g]	124 ; 0.001 / 0.0001
<b>Drying:</b>	
Readability [%]	0.01 / 0.001
Reproducibility in approx. 1g [%]	0.1
Reproducibility in approx. 10g [%]	0.01
Sample weight [g]	0.2 - 124
Result calculations:	Loss and residue in <ul style="list-style-type: none"> <li>• %</li> <li>• ATRO</li> <li>• g/kg</li> <li>• g</li> </ul>
<b>Heating:</b>	
Temperature range [°C]	50 - 230 (Steps 1 °C)
Heating methods	Standard, Boost, Ramp
Intervals	3
Booster	+40% during n:nn min 1 min - 10 min
Ramp	5 min - 20 min
<b>Switch-off criteria:</b>	
Autostop [d/s]	1-99 / 10-180 (Steps 1d / 10s)
Autostop [%/s]	0.01 - 99.00 / 10-180 (Steps 0.01% / 10s)
Adapstop	x
Minimum stop [%]	0.01 - 99.9
Timer stop	1s - 600min
<b>Monitoring:</b>	
Viewing window	x
Audio	x
<b>Printout:</b>	
GLP	x
Printout - Interval	1s - 20min
Sample numbering	x
<b>Memory capacity:</b>	
Methods (with all settings)	100
<b>Operation:</b>	
"Easy access" sample holder	x
Display	LCD, backlit 420*280
Keypad	12 keys including 6 soft keys
Password protection	x
<b>Special features:</b>	
Initial weighing with limits / Initial weighing help	x / x
Software download and update	x
<b>Calibration:</b>	
Balance	automatic with internal calibration weight with a test weight
Temperature	at 100°C and 160°C, selectable
<b>Miscellaneous:</b>	
Timer for date and time	x

Spezification	EM 120-HR
Interface for PCs and printers	RS232
Precisa Slide In Modules	x
Anti-theft protection	Code and mechanically
<b>Connection:</b>	
Mains voltage	230V or 115V Can be switched by changing the unit of heat (may only be done by Precisa Service)
Mains frequency [Hz]	50 - 60
Power consumption [W]	450
<b>Dimensions:</b>	
Instrument housing (WxDxH) [mm]	240x380x177
Weight [kg]	6.7

# Declaration of conformity

Declaration of conformity for apparatus with CE mark  
Konformitätserklärung für Geräte mit CE-Zeichen  
Déclaration de conformité pour appareils portant la marque CE  
Declaración de conformidad para aparatos con disitintivo CE  
Dichiarazione di cofnromitá per apparecchi contrassegnati con la marcatura CE

- English** We hereby declare that the product to which this declaration refers conforms with the following standards.
- Deutsch** Wir erklären hiermit, dass das Produkt, auf das sich diese Erklärung bezieht, mit den nachstehenden Normen übereinstimmt.
- Français** Nous déclarons avec cela responsabilité que le produit, auquel se rapporte la présente déclaration, est conforme aux normes citées ci-après.
- Español** Manifestamos en la presente que el producto al que se refiere esta declaración est ´a de acuerdo con las normas siguientes
- Italiano** Dichiariamo con ciò che il prodotto al quale la presente dichiarazione si riferisce è conforme alle norme di seguito citate.

**Moisture Balance: Precisa EM 120-HR  
with infrared radiator,  
halogen radiator or  
dark radiator**

Mark applied	EU Directive	Standards
	2004/108/EC 2006/95/EC	EN61326 EN61010

Date: 1.05.2011

Signature:



R. Grolimund R & D Manager