

19 PNEUMATIC TOOLS SERIES

PNEUMATIC TOOL

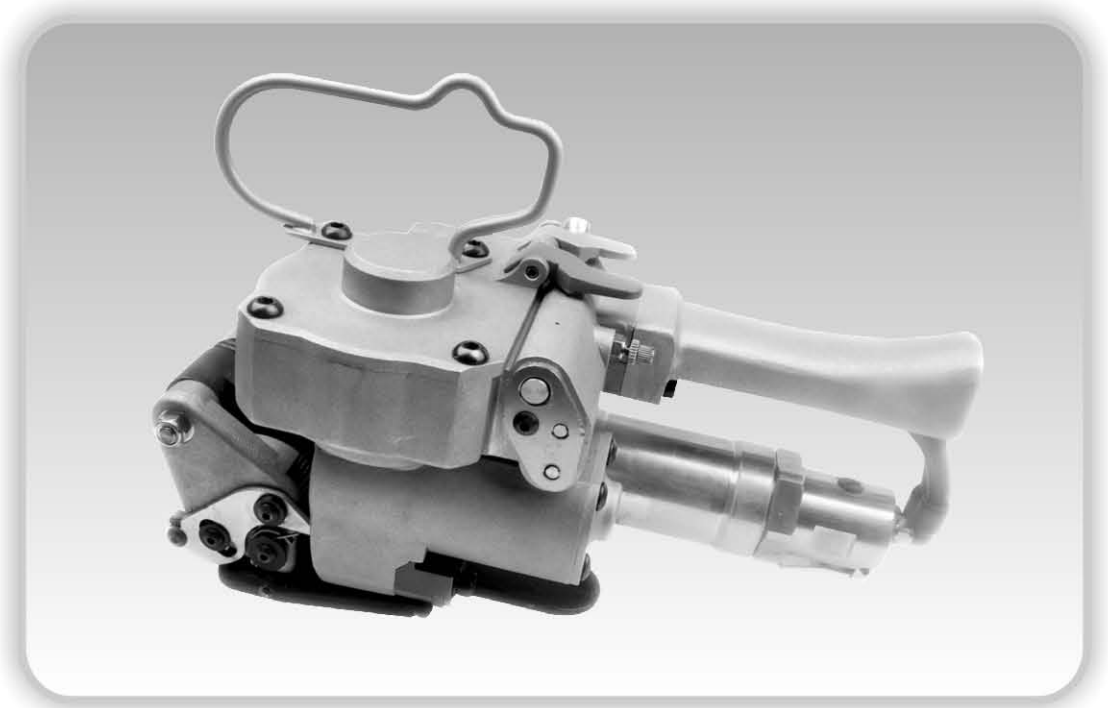

PNEUMATIC TOOLS SERIES

1. CONTENTS

	Page
1. Contents	1
2. Safety Instructions	2~3
3. The Principles of Friction Weld	4~5
4. Specifications and tool options	6
5. Pneumatic Information	7
6. Operating Instructions	8~9
7. Adjustments	10~13
8. Disassemble	14~17
9. Reassemble	18~21
10. Trouble Shooting	22~23
11. Parts List	24~33
12. Pneumatic Diagram	34
13. Optional Suspension	35

For your safety, please read all instructions carefully before operation, and keep it in preparation for usage.

2. Safety Instructions

Before using this tool, read and understand this manual.

General Safety Method

- 1) Remember “safety” is the first priority. Please use this hand tool with proper manners.
- 2) Read this instruction prior to operation, performance.
- 3) Do not remove parts that are designed for safety on this tool.
- 4) Do not remove or deface the labels on this tool.
- 5) Do not put a hand or other body parts between the strap and the package.

Application

This tool is only designed to bind the article with PET strapping.
The width of strap is ranging from 16mm to 19mm.
Never use strapping band as a hock.

Proper Clothes

Wear safety glasses, ear-protector, protective gloves, helmet, and protective footwear.
Protective shoes and long-sleeve shirts. Make sure that all buttons on shirts are fastened.
And make sure that your tie, long-hair or any strings of clothes will not be caught by tool.

Gas Source

Make sure that air hose is durable and oil resistant at outer side.
The quick connect fitting must be designed for this tool.
We recommend HANSEN quick disconnect socket.
Air pressure never exceed 100psi / 7 bar.
Except clean, compressed air, any other air-source type power sources are forbidden.

Ventilation

Quality of air in shop will be contaminated by lube oil.
Proper air ventilation at shop is required.

Vibration

Exposed to excessive vibration in long period might be hazardous to operator's health.
Operation standard must follow a regulation written on IS05349.

Noise

If the noise level is measured above 85dB (A). operator must wear ear protector.
Even the noise level is below 85dB (A). wearing ear protection is recommended.

Protective Eyewear

Tensioned strapping band might cause blindness when strap snaps and hits operator's eyes.
Wear protective eye wear with side shields.

Caution: When cutting the strap, hold the upper portion and stay beside the strap.
The lower strap will snap forward.

Check to be sure that there is no one in the immediate vicinity while cutting strap.
Dust that produced during the maintenance or cleaning process using air gun might cause damages to eyes.

Moving Parts

During operation, moving parts. (Tight Wheel) might catch gloves or other part of your body.
Do not touch the tight wheel while it is running.

Maintenance

Take good care of the tool.
Inspect and clean it regularly by air gun.
Tighten the screws of suspender when they are loosened.
Disconnect tool from power source while replacing parts.

Accidental Hazard In Cutting

Sharp blade of the stationary cutter might cut hands or fingers.
Be careful about it, and wear protective gloves.

3. The Principles of Friction Weld

This tool is a friction weld type sealer. Over lapped thermoplastic band is sealed by heat that is produced by friction movement, so called "Friction Weld".

Compress air to push down the piston of air cylinder. The piston and upper portion of the vibrator are connected with pivot pin.

The vibrator press together over lapped portion of the straps.

Middle portion of vibrator has an oval hole. Oval hole is engaged with eccentric shaft of the pneumatic motor.

Pneumatic motor rotates very high speed (10,000rpm). This makes vibrator to move like the swing of the pendulum in high speed.

Lower strap is fixed by triangle shaped tooth of the bottom die.

Upper strap is vibrating drastically by triangle shaped tooth of the vibrator.

Thus the over lapping strap portion is melted at the interface region.

When the vibration timer reaches to the point of stopping, the weld action stops.

With high pressure, the upper strap and lower strap become stick.

Allow the tool to remain stationary for at least few seconds to ensure that the weld is fully cooled.

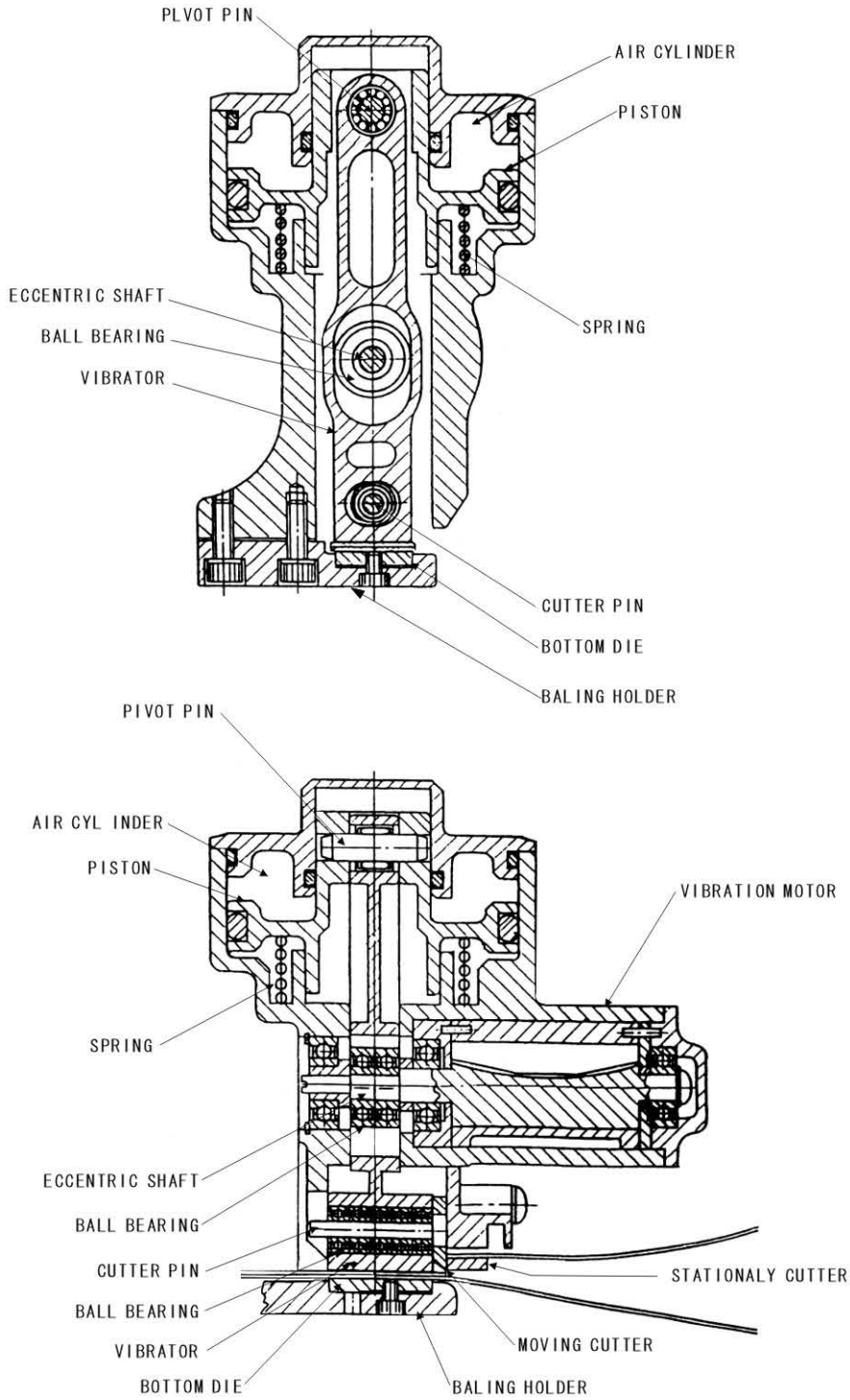

4. Specifications

Model: 19

Binding Constrictive Force (when input pressure is 0.63Mpa) : 3500N

Optimal Working Pressure: 0.63Mpa

Air Pressure: 0.5~0.7 Mpa (72~100 psi)

Tool Weight : 3.8 Kg

Overall Length : 278.5 mm

(Base Length) : 70 mm

Tool Width : 149.5 mm

Tool Height : 173 mm

Strap material : Polyester

Strap width : 13 mm ~ 19 mm

Strap thickness : 0.5~1.5 mm

Lubricant Permitted: 51#

Vibration: accordant with ISO5349

Consumption of Air Compressed: 0.3L/Min

Adjusting Range of Welding Time: 2-5s

Tool Options

1). Tensioner : 3500N (at 0.63 Mpa)

2). Cutter Unit

Heavy duty cutter

The heavy duty cutter consists of stationary cutter and moving cutter.

Designed for strap that has 0.5~1.5mm of thickness.

Friction cutter

Optional friction cutter unit can be used for light-weight

gauge polyester strap that has 0.5~0.7mm of thickness.

3). Overhead suspension

The 19 can be suspended in various positions by using the proper tool hanger (top sealing, horizontal sealing, and vertical sealing).

5. Pneumatic Information

Required air pressure

The air pressure range required by 19 is 72 to 100 psi (5.0 -7.0 Bar).

Air source installation

A filter-regulator-lubricator unit must be installed as close to the air tool as possible.

The air hose must have at least a 6.0 mm (1/4") I. D.

A quick disconnect socket fitting (HANSEN, recommended) must be installed end of the hose.

Moisture filtration

Every branch should have a water leg at its lowest point, with a drain cock which is drained daily.

Lubrication

The air motor must be properly lubricated.

This is achieved by keeping the air line lubricator filled with oil and correctly adjusted. (One drop two minutes)

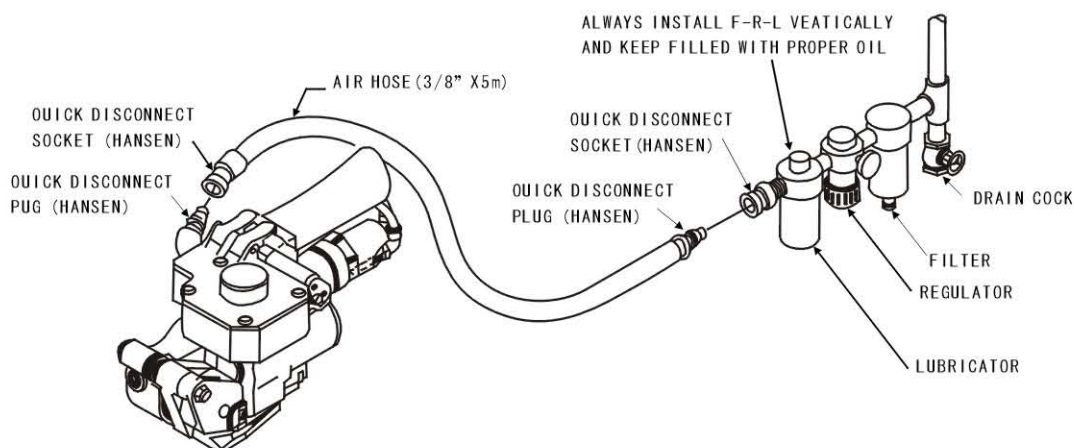

6. Operating Instructions

1) . How to apply strap

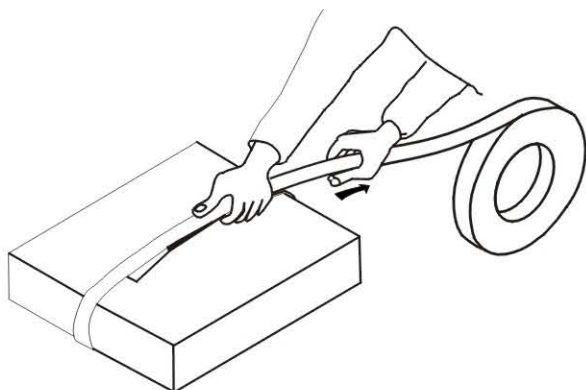

As left figure shows. Apply strap around the package and hold the overlap portion of the straps with your left hand. leave about 300 mm tail.

Pull out excess slack with your right hand.

2) . Loading the strap

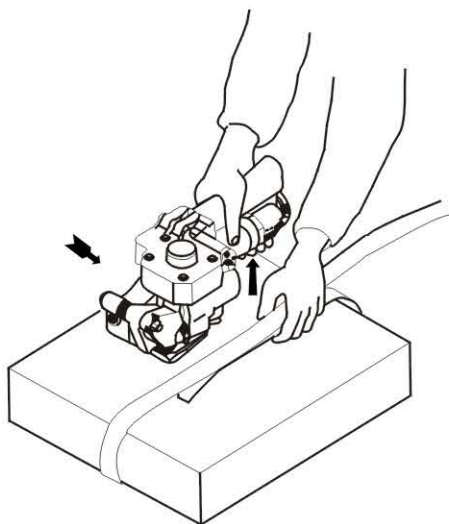

Hold together the handle and the tensioner with your right hand. (Thus insuring maximum separation between the tight wheel and the gripper.) Insert the upper strap and the lower strap at the same time into the space of the tool.

Note : Overlapped straps must be separated by lower blade of the stationary cutter.

Release the tensioner (Tight wheel clamps the strap hard against the gripper plug.)

3) . Tightening the strap

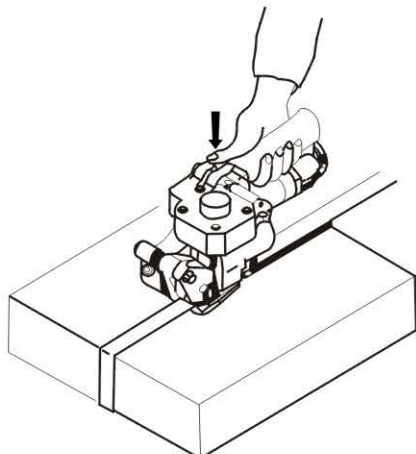

Press the tensioning lever (right-side) with your right thumb until the strap is fully tensioned.

4). Vibration and cutting

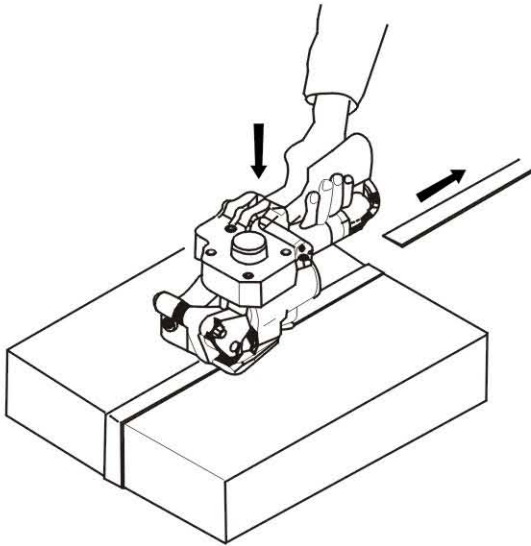

Press the vibration lever (Red) with your right thumb until the strap is cut and vibration-welded.

Note

Please hold the lever until vibration timer stops automatically.

5). Remove the tool

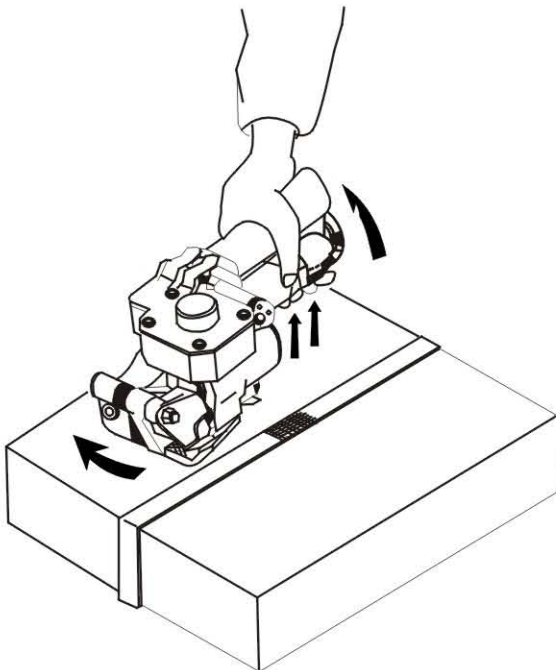

Hold together the handle and the tensioner with your right hand. Squeeze the reverse lever with your right little finger until the strap is loosened from the tight wheel.

Grip together the handle and the tensioner, and swing the tool off from the strap.

Caution

DO not remove the tool from the strap without releasing strap tension.

7. Tension Adjustments

Strap Tension

Strap tension can be adjusted easily by tension adjustment throttle valve, located beneath the tension lever near outside of the handle, using a small screwdriver.

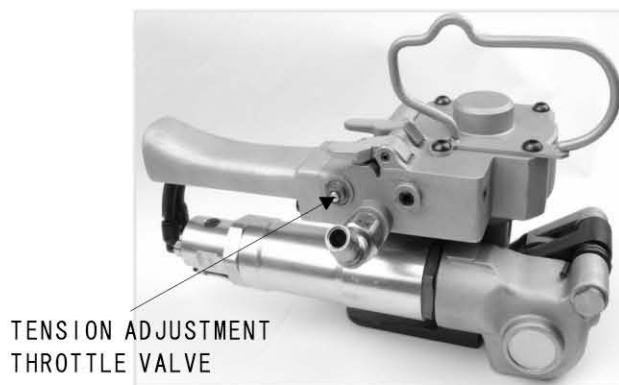

WARNING

Light gauge strap (less than 0.7 mm) may require tension less than 150 Kg. Prevent strap milling or breaking by excessive tension.

Vibration Welding Time

Vibration welding time may need to be adjusted due to size of strap, volume of air supply, Condition of the tool.

Adjustment can be made by turning the small slotted screw, that is located beneath the vibration lever, using a small screwdriver.

Turn the screw le clockwise to increase welding time and counterclockwise to decrease welding time.

A good weld will displace some material along the outer edges of the joint.

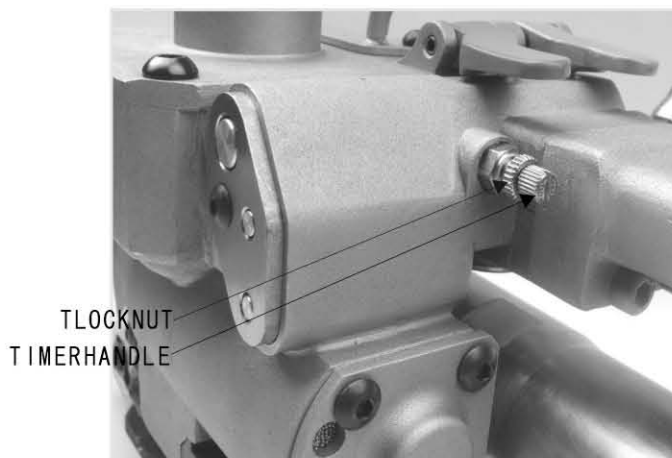

Strap width

1) Side guide

To remove a strap side guide from the tool, remove the screw from the side guide. Replace the new side guide according to the strap size being used, in the same manner in which the initial guide was installed.

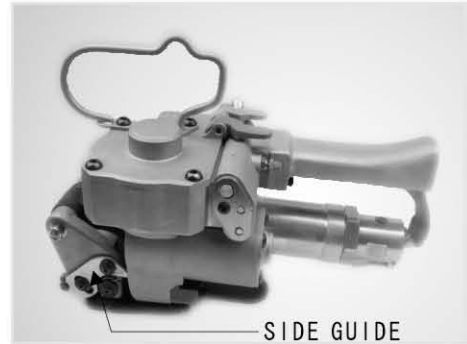
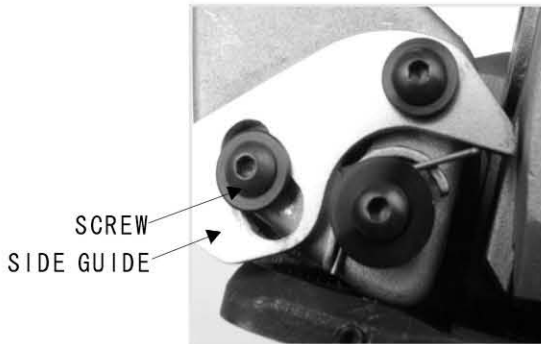

2) Cutter guide

To remove a cutter guide of the heavy duty cutter unit, remove the spring pin from the stationary cutter.

Caution

Don't lose the small compressive spring in the cutter guide.

Reconstruction

Choose one hole among the three holes of the stationary cutter according to the strap size. Outside hole is for 19 mm strap, the middle hole is for 16 mm strap, and inside hole is for 13 mm strap.

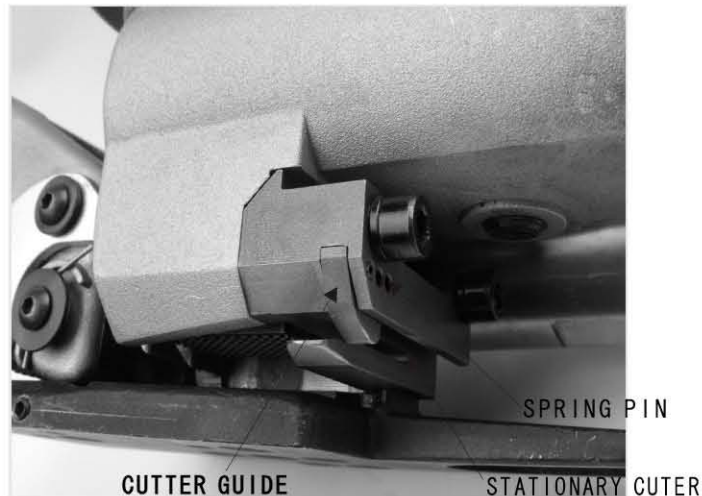

Tightwheel to Gripper Plug clearance A

The tightwheel to gripper plug clearance may require adjustment, when different strap in size is applied.

Check the tightwheel clearance of A (See figure below) by thickness gauge.

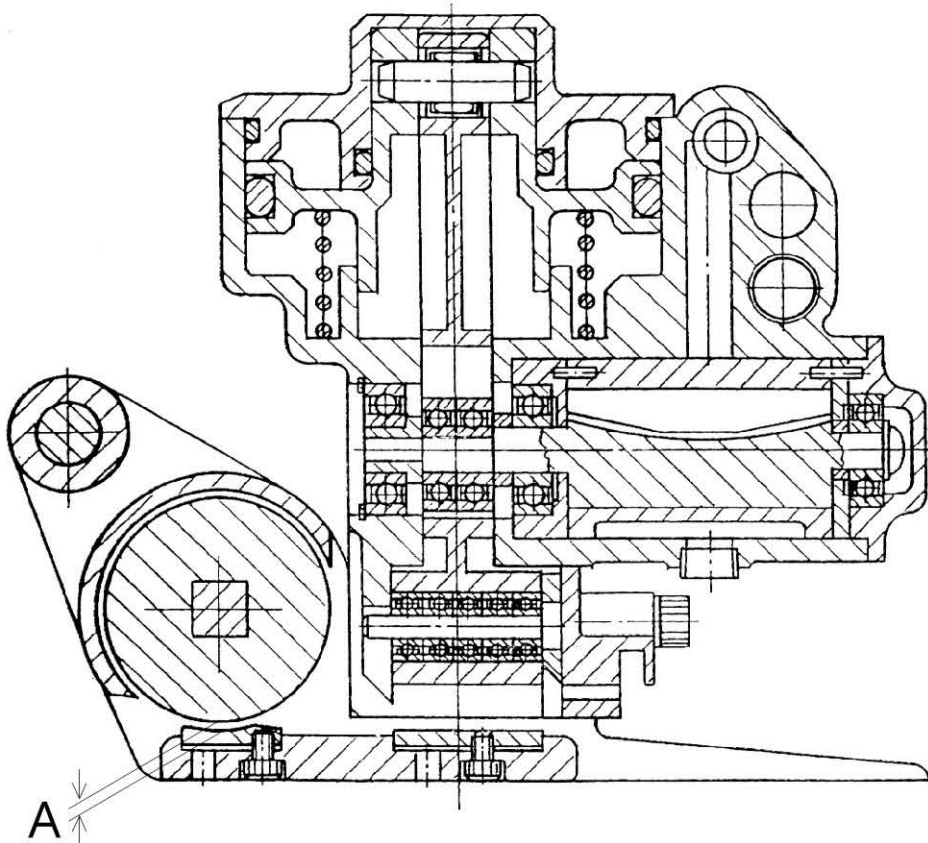

The clearance A must be equal or greater than the thickness of the strap.

The clearance A is pre-adjusted as 1.0 mm strap thickness at the factory.

- (1) In case of the strap has thickness less than 0.8 mm, insert 0.2 mm shim to the bottom of gripper plug.
- (2) In case of the strap has thickness less than 0.6 mm, insert two 0.2 mm shims to the bottom of gripper plug.
- (3) In case of the strap has thickness more than 1.4 mm, insert two 0.2 mm shims between the housing and the baling holder.

Clearance B, (vibrator to bottom die)

Check the clearance B (See figure below) between vibrator and bottom die by thickness gauge.

To obtain this, follow extra procedure below.

- (1) Press the vibration lever (red) for at least 2 seconds.

To make sure that the cylinder piston and vibrator are fully down.

- (2) Check the clearance of B by thickness gauge.

Clearance B has been adjusted to 0.5 mm when using no shim.

In case of a strap has thickness less than 0.6 mm, insert 0.2 mm shim to bottom die.

CAUTION

Do not add too many shims to reduce the clearance B.

Part B will break the tool without clearance.

If the vibrator hits against bottom die, their teeth are broken instantly.

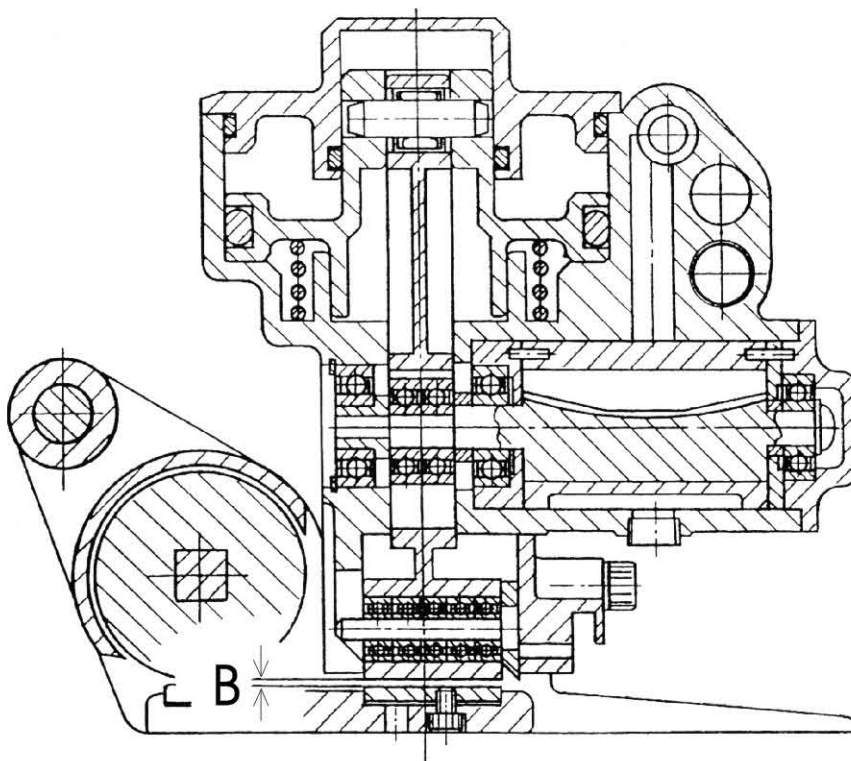

8. Disassemble

Following method shows how to remove the parts for regular maintenance.

This method is the most sufficient way to replace parts that required for renewal.

Tightner, #96, #97, and #98 are rather difficult to assemble.

Please send these parts to our service factory for replace.

1) Baling Holder

- (1) Take out two pieces of tube (#40) from the PL6-01M tube fittings that is located rear end of tightner.

CAUTION Tube can not takeout unless the top ring of fitting is pressed enough.

- (2) Remove the 5 screw (#67) from the bottom of the baling holder (#3) by 4mm hex wrench.
- (3) Now , baling holder with tightner can be separated from housing.

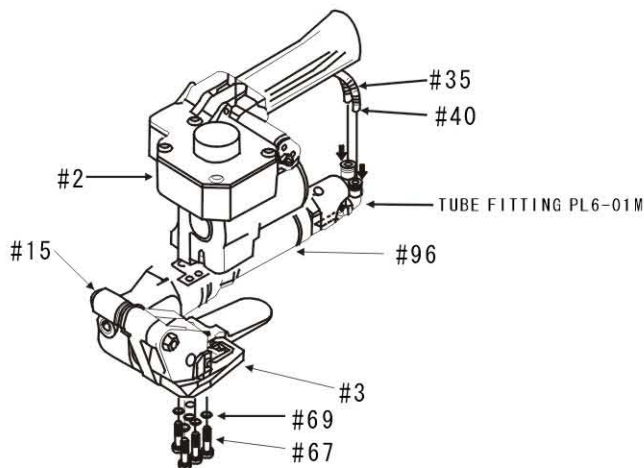

2)Tightwheel and Gripper Plug

- (1) Disassemble U nut M6 (#62) with washer (#42) by 10mm wrench that comes with package, while holding the hanger pin (#15) by 13mm wrench that is also included in the package.
- (2) Remove whole unit of side guide assembly (#11) from the hanger pin by sliding the unit to the left.
- (3) Remove 2 screws M4×4 (#74) by 3mm hex wrench. Now, bottom die (#7), and hold-down plate tooth (#9) can be removed.

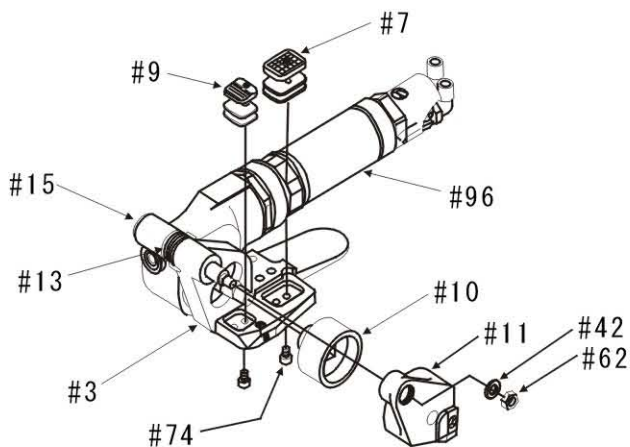

3) Hanger Pin

- (1) Tightner (#96), gripper spring (#13), and baling holder (#3) can be taken apart by pulling out hanger pin (#15).

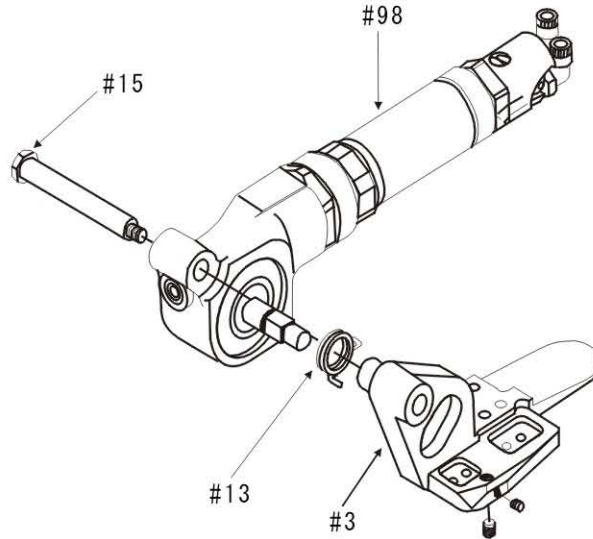

4) Cutter Unit

- (1) Stationary cutter can be removed by taking off 2 screws M5×30 (#64) by 4mm hex wrench.
- (2) Remove upper moving cutter by disengaging from cutter pin (#37).
- (3) Check the cutter blades. Replace them if it is worn out.
- (4) Take out cutter pin (#37) and 5 bearings (#46) at same time.

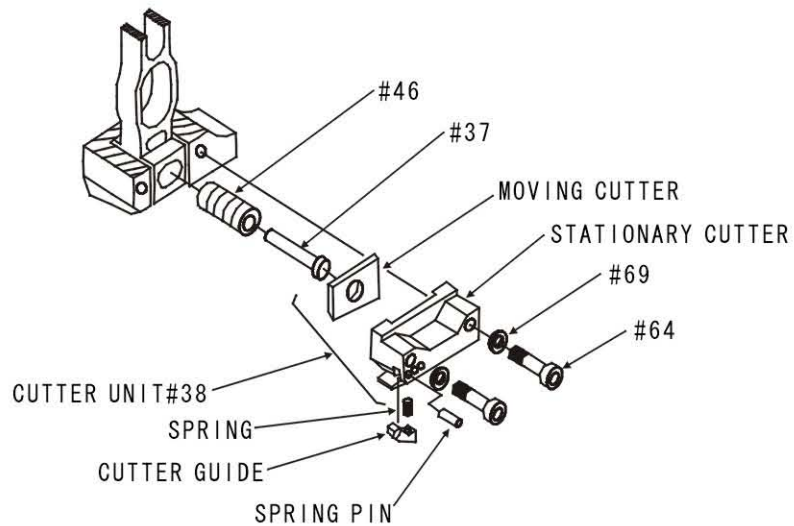

5) Vibration Motor

- (1) Remove 4 screws M5×12 (#63) that hold end cover (#30) by 3mm hex wrench. Hit the tip of rotors shaft (#26).
- (2) Sleeve (#29), ball bearings (#45), spacer (#28) comes out with rotor from end of the housing.

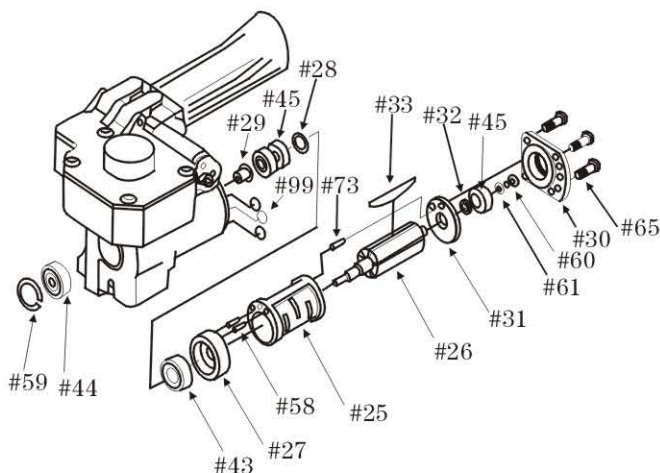

6) Cylinder Cover and Piston

- (1) Take out 4 screws M6×16 (#63) from top of the cylinder cover (#4) by 4mm hex wrench.
- (2) By pushing up the bottom of pressure piston (#34), cylinder cover comes out a little from the housing. Use screw driver to pull out cylinder cover little by little from the housing.
Caution Be Careful not to lose the small spring (#22), or other parts that hopping up from the housing.
- (3) To take out pivot pin (#23), pushing pin out by 4mm hex wrench.
- (4) By supplying air pressure by air gun through 6.5mm diameter hole under the housing. Piston (#6) and spring (#24) can be taken out.

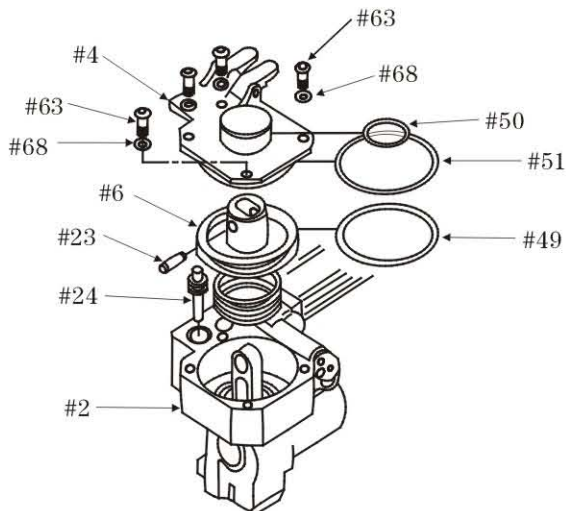

7) Vibrator

(1) Take out vibrator (#8) from the bottom of the housing.

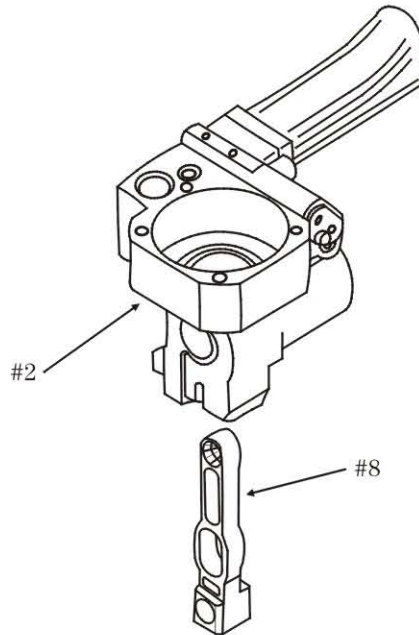

8) Pressure piston

(1) Take out pressure piston (#34) by pushing up the 6mm diameter piston rod.

Do not loose O-ring (#52).

Caution when disassemble optional equipment that attached to housing, pay extra caution on preventing the small segregative parts from dropping down.

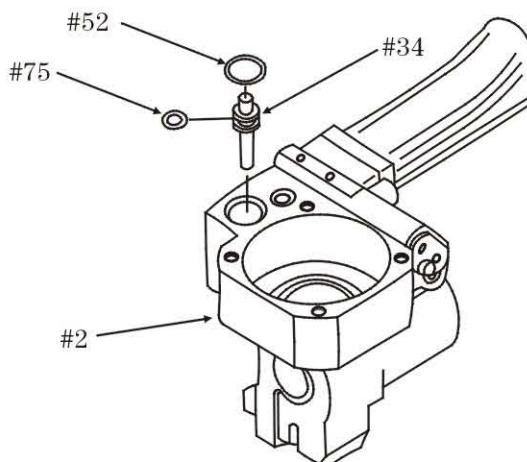

9. Reassemble

1) Valve parts

- (1) Assemble one nylon ball (#55) , spring (#22 for release valve) and O-ring S18 (#87) on top of the housing (#2).
- (2) Apply pressure piston (#34) above the housing.
- (3) Assemble 2 valve pin (#14) into the pin holes located on top of the housing.

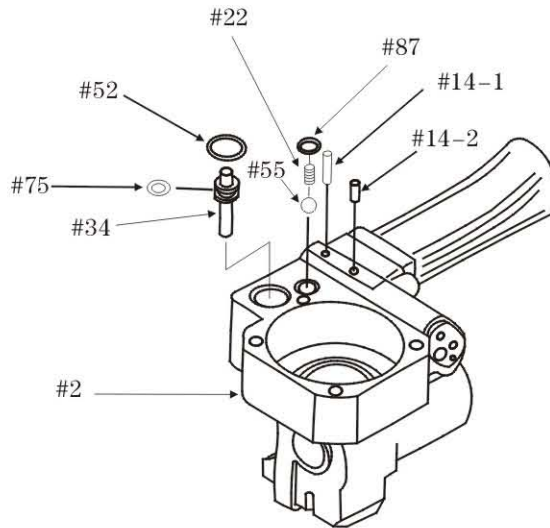

2) Vibrator

- (1) Insert vibrator (#8) from the bottom of housing. Attention on the direction, front or back.
- (2) Assemble 5 ball bearings (#46) to cutter pin (#37).
- (3) Apply this cutter pin unit to vibrator through horizontal hole.

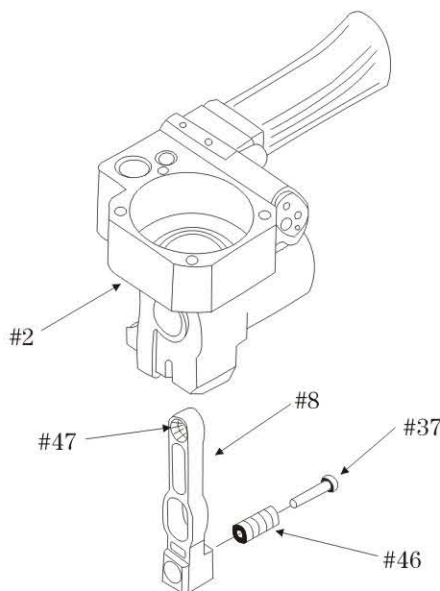

9. Reassemble

1) Valve parts

- (1) Assemble one nylon ball (#55), spring (#22 for release valve) and O-ring S18 (#87) on top of the housing (#2).
- (2) Apply pressure piston (#34) above the housing.
- (3) Assemble 2 valve pin (#14) into the pin holes located on top of the housing.

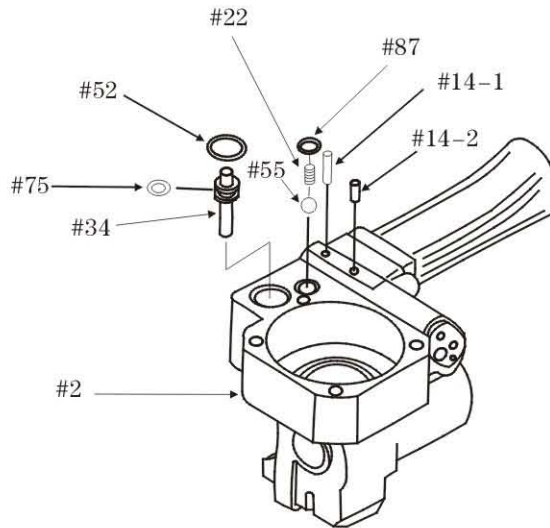

2) Vibrator

- (1) Insert vibrator (#8) from the bottom of housing. Attention on the direction, front or back.
- (2) Assemble 5 ball bearings (#46) to cutter pin (#37).
- (3) Apply this cutter pin unit to vibrator through horizontal hole.

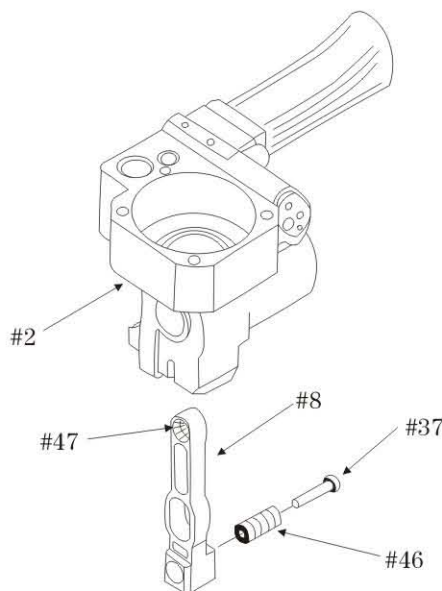

3) Piston

- (1) After lubricate with grease inside of the housing, insert coil spring (#24) inside of 50mm diameter hole.
- (2) Assemble O-ring P60 (#49) to piston(#6), then apply grease. Insert this unit to cylinder.

Caution Pivot pin must face front.

- (3) Insert Pivot pin (#23) into both axle hole of the piston and vibrator.
- (4) Apply O-ring P28 (#50), and O-ring G65 (#51) on cylinder cover (#4).
- (5) Overlap the above mentioned cylinder cover to the piston. Then, assemble housing with 4 button bolts (#63) and spring washer (#68).

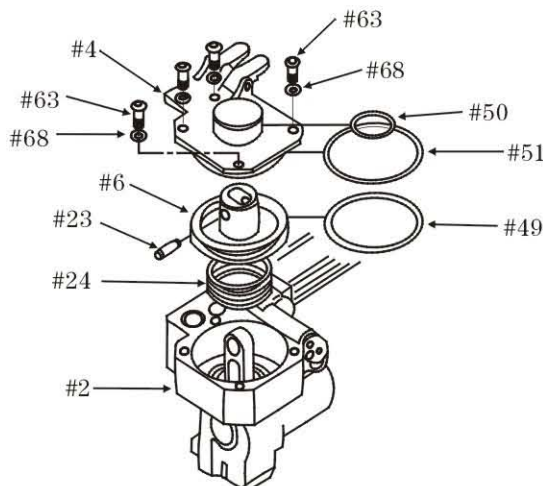

4) Vibration Motor

- (1) Assemble spacer (#28), 2 ball bearings(#45), sleeve(#29) on rotor (#26).
Insert the unit of air motor to the housing through the opening for motor.
Then, fix into ball bearing(#44)through a large opening of vibrator.
- (2) Fasten end-cover (#30) with 4 button bolt M5×12(#65).

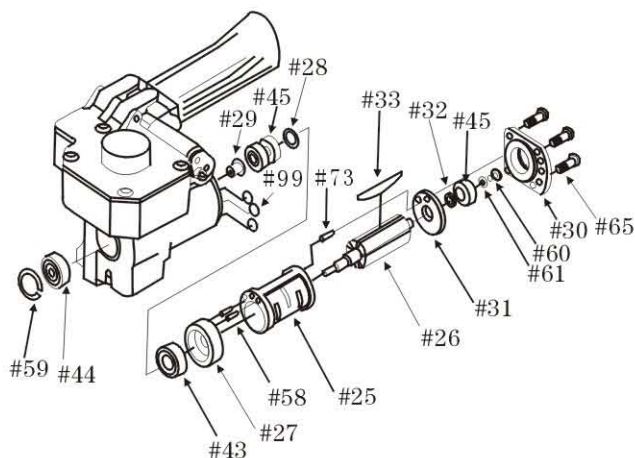

5) Cutter Unit

- (1) Apply moving cutter (#38) to head part of cutter pin (#37), study the direction of cutter blade.
- (2) Apply cutter holder, or stationary cutter (#38) over the cutter blade. Fasten by 2 screw M5×30 (#64) and 2 pieces of washer M5 (#69).

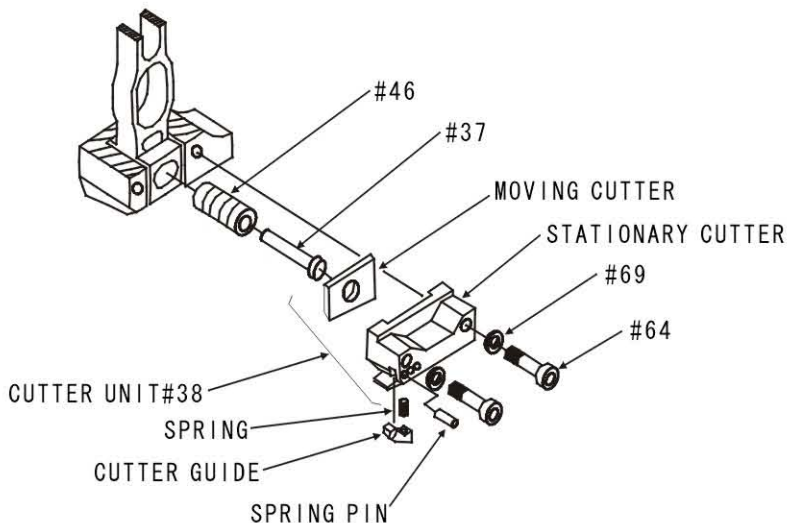

6) Hanger Pin

- (1) Place gripper spring (#13) in front of baling holder (#3), then apply tightner (#96). Insert hanger pin (#15).
- (2) Assemble tightwheel (#10) to main shaft of tightner.
- (3) Insert side guide assembly (#11) to hanger pin. Insert end part of main shaft to DU bush of side guide assembly.
- (4) Hold the head of hanger pin (#15) by 13mm wrench. Fasten flat washer M6 (#42) and U-nut M6 (#62) by 10mm wrench.

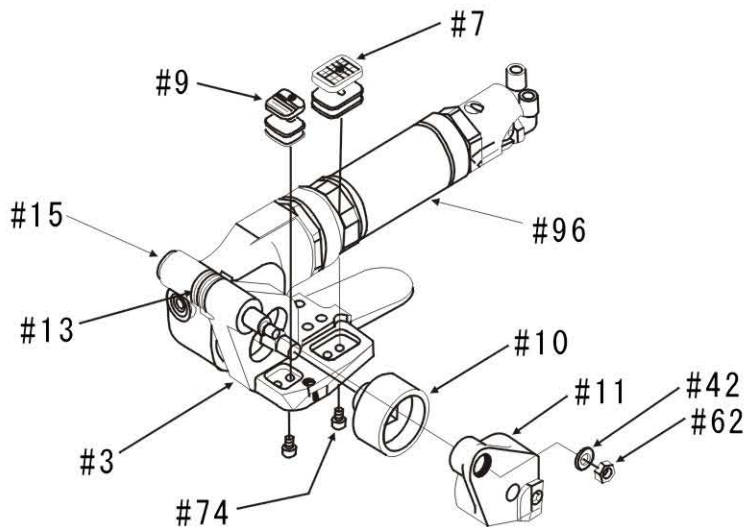

7) Baling Holder

- (1) Approach the whole unit of baling holder (#3), tightner (#96) is fixed to baling holder by hanger pin (#15). to housing (#2) from the left side baling holder (#3).
- (2) Assemble 5 screw M5×15 (#67) and 5 pcs of spring washers (#69) to baling holder from the bottom and fix them by 4mm hex wrench.

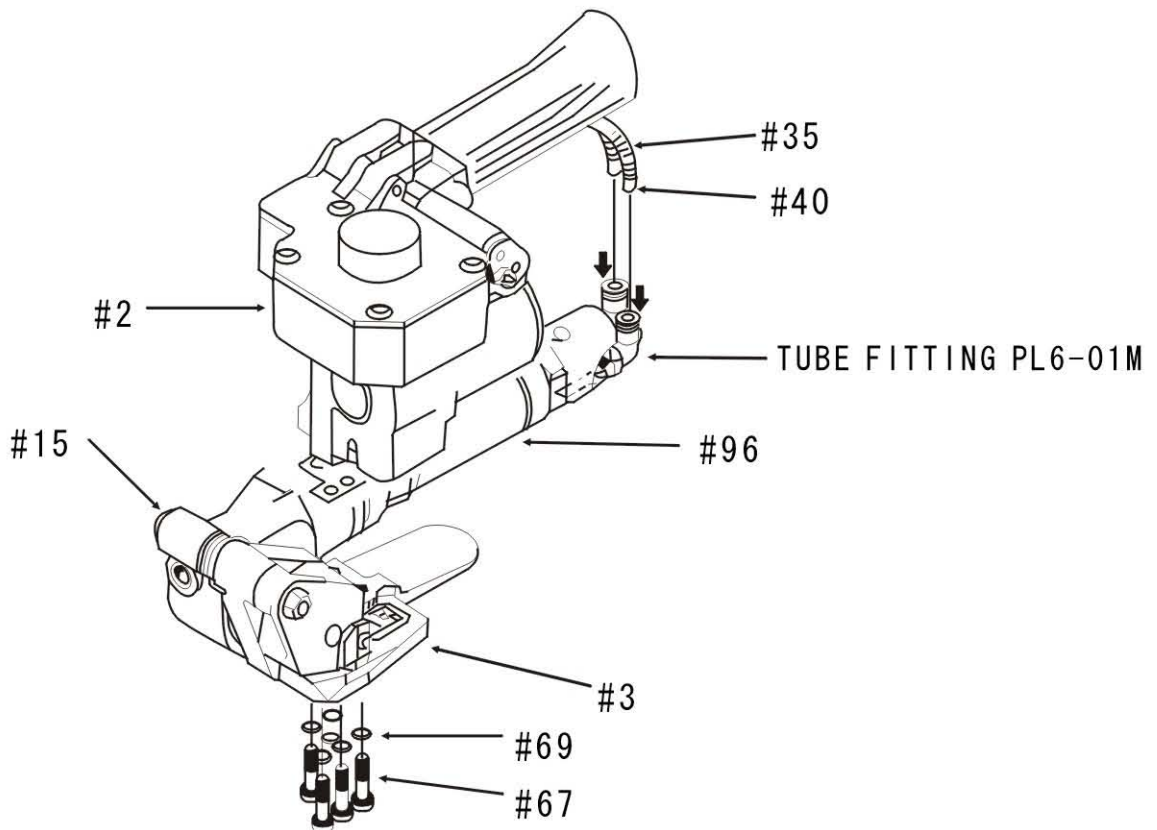

8) Air Supply tube

- (1) Insert 2 lines of tube (#40) with stress spring (#35) to inlet fittings that is located at the end of the tightner.

10. Trouble Shooting

The following items are the most common types of tool troubles.

1) Tensioning operation

SYMPTOM	CAUSE	REMEDY
Tensioning air motor fails to start.	<ol style="list-style-type: none"> 1. Foreign object in air motor. 2. The motor is dry. Lack of lubrication. 3. Lack of air caused by improper adjustment on air valve 	<ol style="list-style-type: none"> 1. Overhaul is required. Send the tool to manufacture. 2. Add several drops of oil into the motor through the air inlet. 3. Readjust the throttle valve, supply enough air flow.
Tightwheel milling the surface of upper strap.	<ol style="list-style-type: none"> 1. Too mach clearance between tightwheel and gripper plug. 2. Too mach tension regarding thickness of strap. 3. Tightwheel is clogged with dirt or strap residue. 4. Worn teeth on the tightwheel. 	<ol style="list-style-type: none"> 1. Adjustment by adding shims, refer to P12 tool adjustments. 2. Adjust strap tension by throttle valve using a small screwdriver. 3. Clean teeth on the tightwheel by air gun or with brush. 4. Replace the tightwheel, refer to P14 parts removal.
During tensioning Tool moves forward, or dosen' t clamp the bottom strap.	<ol style="list-style-type: none"> 1. The gripper plug is clogged with strap residue. 2. Worn teeth on the gripper plug. 3. Too mach strong strap tension. 	<ol style="list-style-type: none"> 1. Clean teeth on the gripper plug, blow out the residue by air gun. 2. Replace the gripper plug , refer to P14 Parts removal. 3. Adjustments of throttle valve, using a small screwdriver.

Cautions during tensioning operation

- (1) After strap is applied around the package, and hold the overlap portion of the straps with your lefthand, pull out excess slack with your right hand.
- (2) Make sure the overlapped part of strap inside the tool be aligned.
- (3) Excessive tension causes strap milling or breaking during tensioning operation, reduce strap tension by controlling the throttle valve.

2) Heat Sealing Operation (meld operation)

<p>Incomplete or no weld</p>	<ol style="list-style-type: none"> 1) Too short set weld time adjustment. 2) Insufficient air supply pressure. 3) Inner diameter of hose is too small. 4) Teeth is filled with residue or worn. 5) Vibration motor is dry, and lack of lubrication. 	<ol style="list-style-type: none"> 1) Adjust weld time as required, refer to this manual. 2) Supply 72 psi or more air pressure. 3) Replace to hose with 6.4mm or more diameter. 4) Clean up the teeth, or replace vibrator as required. 5) Add several drops of oil into the motor through the air inlet.
<p>Strap is over welded, or cut during the welding process.</p>	<ol style="list-style-type: none"> 1) Lack of strap thickness. 2) Too long welding time. 3) Too short time to cool off the friction-welded portion. 	<ol style="list-style-type: none"> 1) Use proper gauge strap to prevent strap cut. 2) Decrease weld timing as needed, refer to this manual. 3) Wait 3 seconds after welding process.
<p>Tool can not be removed from the strap after welding operation is completed.</p>	<ol style="list-style-type: none"> 1) Tightwheel does not reverse. Tension of strap can not be released. 2) Vibrator dose not lift up from the straps. 	<ol style="list-style-type: none"> 1) Press the reverse valve to release the tension on strap. 2) Grip the tightner and handle at the same time. Engage the tightner to release valve, then open the check valve.

Cautions during sealing operation

- (1) Weld time adjustments can be made by turning the small screw, located beneath the weld lever (red) at end of housing, using a small screwdriver.
- (2) Turn the handle clockwise to increase weld time and counterclockwise to decrease weld time. After turning the handle, fasten the locknut.
- (3) A good weld will displace some material along the outer edges of the joint, but, too long welding time decreases the adhesive strength on PET band.
- (4) Failure to wait 3 seconds can result in an improperly formed joint which may lead to joint separation.

11. Parts List

Original KOKO spare parts must be used exclusively !
When ordering, please indicate part NO. and part name.

19 Parts List P25 ~ P30

Tensioner Parts List P31 ~ P32

Assembly Drawing P33

MODEL 19 Combination Strapping Tool

Ref. No .	Part Name	Part No .	Q' ty
2	Housing	A01	1
3	Baling Holder	A02	1
4	Cylinder Cover	A03	1
5	Release Handle	A04	1
6	Piston	A05	1
7	Bottom Die	A06	1
8	Vibrator	A07	1
9	Gripper plug	A08	1
10	Tight Wheel	A09	1
11	Side Guide Assembly	A10	1
13	Holder Spring	A11	1
14-1	Valve Pin(L)	A12-1	1
14-2	Valve Pin(S)	A12-2	1
15	Hanger Pin	A13	1
16-1	Valve Lever (Tensioning)	A14-1	1
16-2	Valve Lever (Vibration)	A14-2	1
17	Valve Cover	A15	1
18	Release Pin Guide	A16	1
19	Release Pin	A17	1
20	Spring(Main Valve)	A18	1
21	Spring(Release Pin)	A19	1
22	Spring(Release Valve)	A20	1
23	Pivot Pin	A21	1
24	Spring(Air Cylinder)	A22	1
25	Motor Cylinder	A23	1
26	Rotor	A24	1
27	Front Cylinder Cover	A25	1
28	Spacer	A26	1
29	Sleeve	A27	1

Ref. No .	Part Name	Part No .	Q' ty
30	End Cover	A28	1
31	Rear Cylinder Cover	A29	1
32	Rotor Ring	A30	1
33	Vane	A31	5
34	Pressure Spring	A32	1
35	Stress Spring	A33	2
36	Shim(Gripper Plug)	A34	2
37	Cutter Pin	A35	1
38-1	Cutter Parts 19mm (16mm, 13mm)	A36-1	1
38-2	Moving Cutter	A36-2	1
39	Shim(Bottom Die)	A37	2
40	Air Tube (U2-6×4)	A38	2
41	Tube Fitting (PH6-01M)	A39	2
42	Flat Washer (M6)	A40	1
43	Ball Bering (608ZZ)	A41	1
44	Ball Bering (627ZZ)	A42	1
45	Ball Bering (626ZZ)	A43	3
46	Ball Bering (685ZZ)	A44	5
47	Needle Bearing (F-79)	A45	1
48	DU Bushing	A46	1
49	O-Ring (P60)	A47	1
50	O-Ring (P28)	A48	1
51	O-Ring (G65)	A49	1
52	O-Ring (S18)	A50	2
53	Screw, Button Hd. Cap (M5×25)	A51	2
54	Urethan Ball (1/2" Φ12.7)	A52	1
55	Nylon Ball (19/64" Φ7.54)	A53	2
56	Plug	A54	2
57	Spring Pin (Φ4×40)	A55	1

Ref. No .	Part Name	Part No .	Q' ty
58	Spring Pin (Φ2.5×8)	A56	2
59	Retaining Ring (Φ22)	A57	1
60	unbrako Loc-wel (M4×10)	A58	1
61	Flat Washer (M4)	A59	1
62	U Nut (M6)	A60	1
63	Screw, Button Hd. Cap (M6×16)	A61	4
64	Screw, Button Hd. Cap (M5×30)	A62	2
65	Screw, Button Hd. Cap (M5×12)	A63	4
66	Clamping Screw (M5×8)	A64	1
67	Screw, Soc. Hd. Cap (M5×15)	A65	5
68	Spring Washer (M6)	A66	4
69	Spring Washer (M5)	A67	9
70	Clamping Screw (M8×8)	A68	1
71	Clamping Screw (M5×6)	A69	1
72	Clamping Screw (M4×5)	A70	2
73	Spring Pin (Φ2.5×11)	A71	1
74	Screw, Soc. Hd Cap (M4×4)	A72	1
75	O-Ring (P12)	A73	1
76	O-Ring (S5)	A74	1
77	Spring (Tightner)	A75	1
78	Throttle Valve	A76	1
79	Throttle Valve Cover	A77	1
80	Shutoff Valve	A78	1
81	Mini Cylinder	A79	1
82	Mini Piston	A80	1
83	Tank Cover	A81	2
84	Spring (Mini Cylinder)	A82	1
85	Cover Plate	A83	1
86	Needle unit Ina-14-444	A84	1

Ref. No .	Part Name	Part No .	Q' ty
87	O-Ring (S9)	A85	3
88	O-Ring (S9)	A86	1
89	Flat Washer (S7)	A87	1
90	O-Ring (S4)	A88	1
91	O-Ring (Ss-090)	A89	1
92	U Nut (M4)	A90	1
93	Flat Washer (M4)	A91	1
94	Screw, Soc. Hd. Cap (M4×12)	A92	1
95	Turn Elbow	A93	1
96	Tightner (High Tension)	A94	(1)
97	Tightner (Medium Tension)	A95	1
98	Tightner (Low Tension)	A96	(1)
99	Filter Element	A97	3
100	Mini Cylinder Cover	A98	1
101	O-Ring (S11.2)	A99	2
102	O-Ring (S12)	A100	1
103-1	Suspension (Top Sealing)	A101-1	1
103-2	Suspension (Vertical Sealing)	A101-2	(1)
103-3	Suspension (Horizontal Sealing)	A101-3	(1)

Side Guide Chart (A10)

Ref. No .	Part Name	Part No .	Q' ty
9-3	stopper 13mm	A10-9-3	1
9-2	stopper 16mm	A10-9-2	1
9-1	stopper 19mm	A10-9-1	1
8	Screw, Button Hd. Cap M4×6	A10-8	1
6	Screw, Button Hd. Cap M4×8	A10-6	3
5	torsion spring	A10-5	1
4-1	sleeve liner	A10-4-1	1
4-2	sleeve liner	A10-4-2	2
3	panel	A10-3	1
2	hook	A10-2	1

CUTTER UNIT (A36)

Ref. No .	Part Name	Part No .	Q' ty
46	Ball Bering	A44	1
37	Cutter Pin	A35	1
38-1-1	Stationary Cutter	A36-1-1	1
38-1-2	Spring	A36-1-2	1
38-1-3	Cutter Guide	A36-1-3	1
38-1-4	Spring Pin $\Phi 2 \times 16$	A36-1-4	1
38-2	Moving Cutter	A36-2	1
69	Spring Washer M5	A67	2
64	Screw, Button Hd. Cap M5 \times 30	A62	2

19 Tensioner Assembly

Ref. No .	Part Name	Part No .	Q' ty
2	Gear Case	B01	1
3	Spiroid Gear	B02	1
4	Spiroid Pinion	B03	1
5	Bearing Case	B04	1
6	Cover Plate	B05	1
7	Motor Case	B06	1
8	Internal Gear	B07	1
9	Valve Body	B08	1
10	Ring	B09	1
11	Adapter Sleeve	B10	1
12	Cylinder	B11	1
13	Front Cylinder Cover	B12	1
14	Rear Cylinder Cover	B13	1
15	Rear Bearing Cover	B14	1
16	Rotor	B15	1
17	Rotor Ring	B16	5
18	Vane	B17	1
19	Idle Frame	B18	2
20	Idle Gear	B19	2
21	Idle Gear Shaft	B20	1
23	Ring	B21	1
27	Valve Pin	B22	1
28	Valve Spring	B23	1
29	Bottom Cap	B24	1
33	Ball bearing (6300ZZ)	B25	3
35	Ball bearing (6001ZZ)	B26	1
36	Ball bearing (6000ZZ)	B27	2
37	Needle Cage (K4-7-7)	B28	1
38	Ball bearing (627ZZ)	B29	1

19 Tensioner Assembly

Ref. No .	Part Name	Part No .	Q' ty
2	Gear Case	B01	1
3	Spiroid Gear	B02	1
4	Spiroid Pinion	B03	1
5	Bearing Case	B04	1
6	Cover Plate	B05	1
7	Motor Case	B06	1
8	Internal Gear	B07	1
9	Valve Body	B08	1
10	Ring	B09	1
11	Adapter Sleeve	B10	1
12	Cylinder	B11	1
13	Front Cylinder Cover	B12	1
14	Rear Cylinder Cover	B13	1
15	Rear Bearing Cover	B14	1
16	Rotor	B15	1
17	Rotor Ring	B16	5
18	Vane	B17	1
19	Idle Frame	B18	2
20	Idle Gear	B19	2
21	Idle Gear Shaft	B20	1
23	Ring	B21	1
27	Valve Pin	B22	1
28	Valve Spring	B23	1
29	Bottom Cap	B24	1
33	Ball bearing (6300ZZ)	B25	3
35	Ball bearing (6001ZZ)	B26	1
36	Ball bearing (6000ZZ)	B27	2
37	Needle Cage (K4-7-7)	B28	1
38	Ball bearing (627ZZ)	B29	1

Ref. No .	Part Name	Part No .	Q' ty
39	Ball bearing (696ZZ)	B30	1
40	Needle Bearing (Bk0810)	B31	2
41	Needle Bearing (F-48)	B32	1
42	Retaining Ring (R48)	B33	1
44	Retaining Ring (S10)	B34	1
49	Nylon Ball ($\Phi 7.54$)	B35	1
51	Pan Head Screw (M4 \times 10)	B36	1
52	Plane Washer (M4)	B37	1
53	Spring Pin ($\Phi 2.5 \times 12$)	B38	2
54	Spring Pin ($\Phi 2.5 \times 8$)	B39	1
56	Valve Lever	B40	1
57	Spring Pin ($\Phi 3 \times 20$)	B41	2
58	Fitting (Elbow Mini) (PL6-01M)	B42	2
	Protective Casing	B43	1
	Screw, Button Hd. Cap (M5 \times 12)	B44	1
	Gasket	B45	1

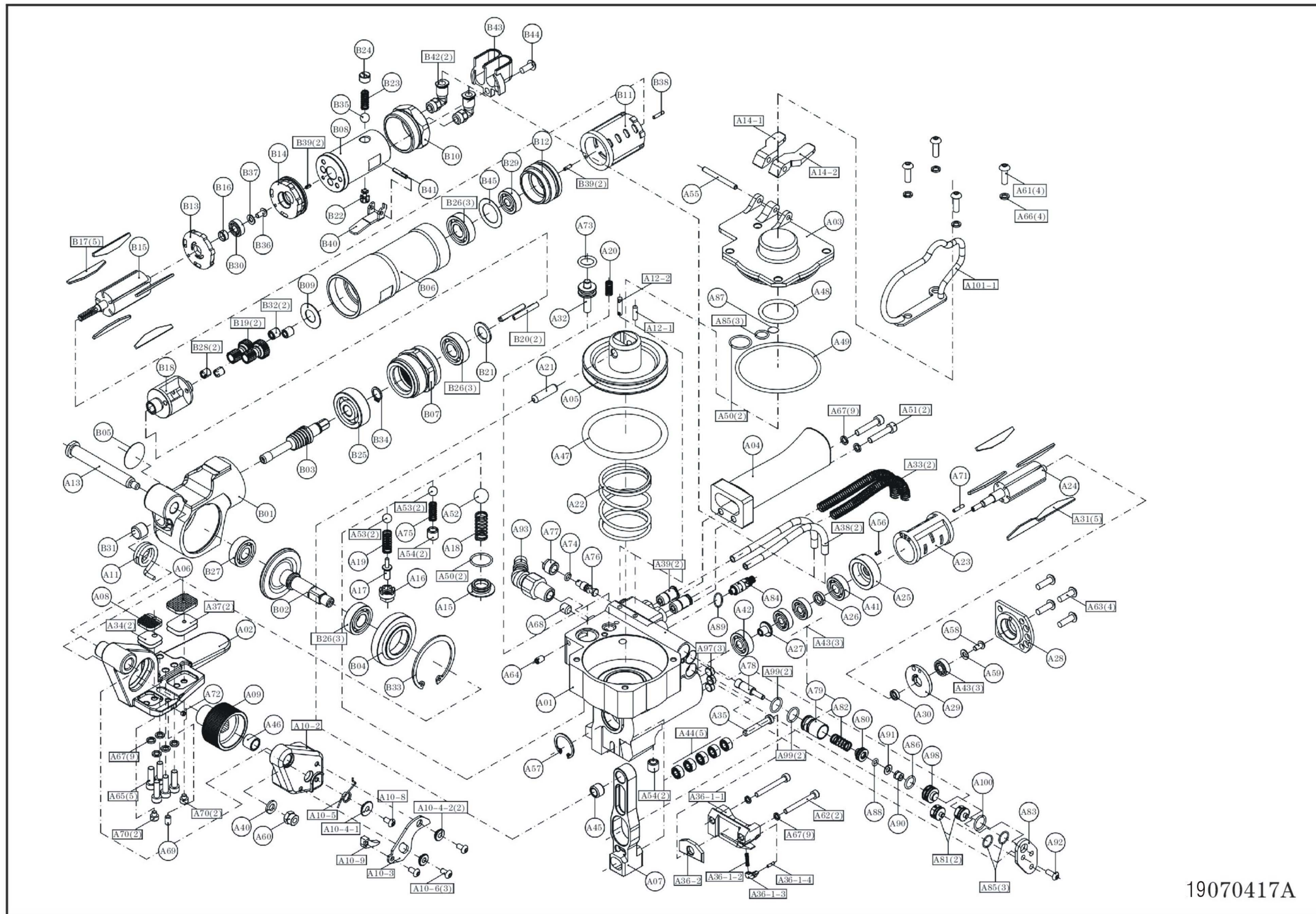

19070417A

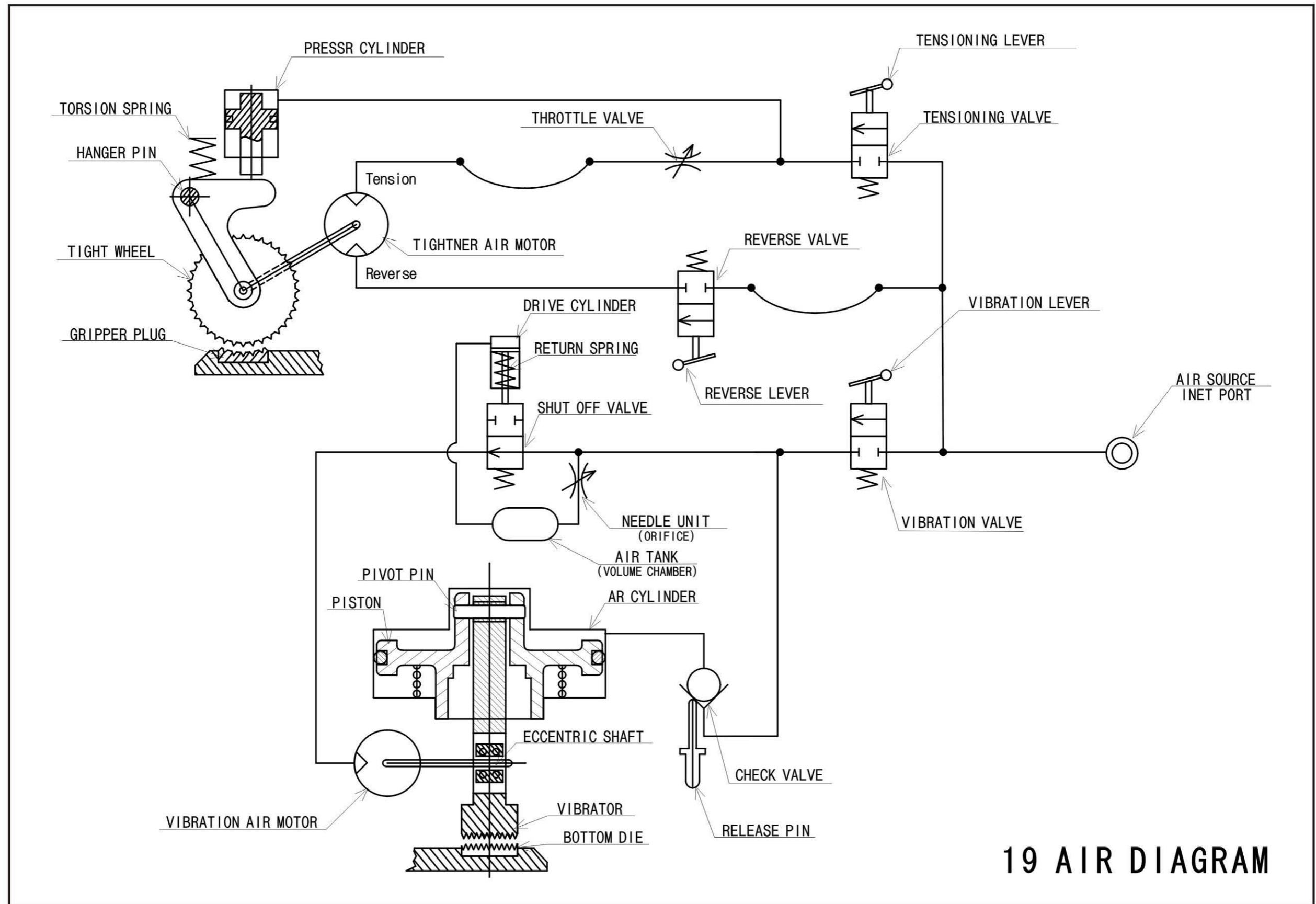

19 AIR DIAGRAM