

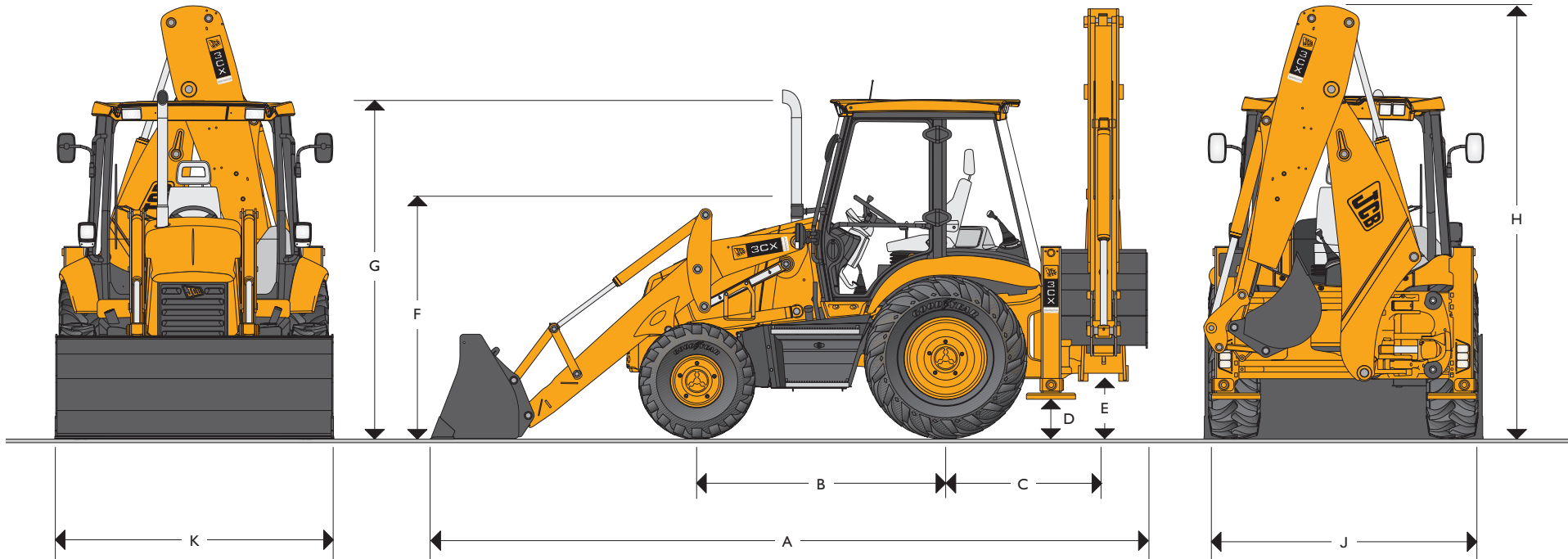

JCB BACKHOE LOADER | 3CX CONTRACTOR



MAX. ENGINE POWER: 74.5kW (100hp)
 MAX. BACKHOE DIG DEPTH: 5.46 metres (17ft 11in)
 MAX. LOADER CAPACITY: 1.0m³ (1.32yd³)



STATIC DIMENSIONS

JCB Backhoe Loaders feature heavy duty one piece mainframe, componentised driveline and fully enclosed engine compartment. All fluid and component compartments are lockable using the ignition key.

Machine model	3CX Contractor
	m (ft-in)
A Total travel length	5.62 (18-5)
B Axle centreline distance	2.17 (7-1)
C Slew centre to rear axle centre distance	1.36 (4-6)
D Stabiliser feet clearance	0.37 (1-2)
E Kingpost clearance	0.52 (1-8)
F Steering wheel centre height	1.94 (6-4)
G Cab roof height	2.91 (9-6)

Machine model	3CX Contractor
	m (ft-in)
H Total travel clearance	3.61 (11-10)
J Rear frame width	2.35 (7-8)
K Shovel width	2.35 (7-8)
J* Rear frame width	2.24 (7-4)
K* Shovel width	2.23 (7-4)

* Narrow option



JCB BACKHOE LOADER | 3CX CONTRACTOR



GROUND LINE ANGLES

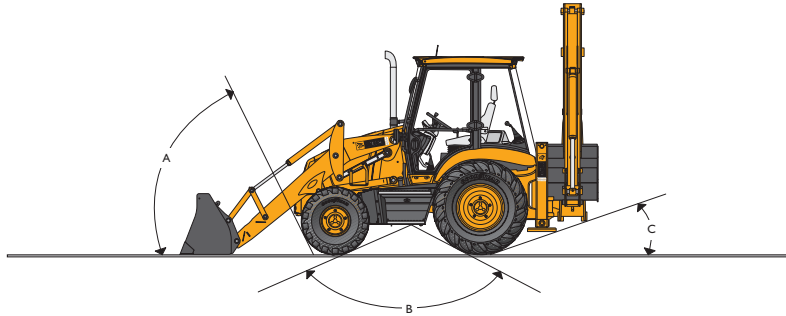

- A Approach angle 66°
- B Interference angle/ramp to ground plane 120°
- C Departure angle 20°

OPERATING WEIGHTS

Operating weight includes machine equipped with 610mm excavator bucket, Extradig 6-in-1 shovel with forks and full fuel tank.

Machine model	3CX Contractor
	kg (lb)
Weight	8070 (17800)

ENGINE

Four cylinder, direction injection diesel. Gear driven water pump, cast iron engine sump, spin-on oil and fuel filters, water separator, dual element air cleaner, glow plug cold start aid.

Machine model		Turbo
Displacement		4.4 Ltr
No. of cylinders		4
Bore size	mm	105
Stroke	mm	127
Rated engine RPM		2200
Power ratings		
Gross ISO/TR 14396 and SAE J1995	kW (HP)	74.5 (100)
SAE net ISO 9249 (EEC 80/1269 and SAE J1349)	kW (HP)	70.5 (94.5)
Torque ratings		
SAE gross ISO/TR 14396 and SAE J1995	Nm (lbf ft)	415 (306)
SAE net ISO/TR 9249 (EEC 80/1269) and SAE J1349	Nm (lbf ft)	407 (300)
Max. torque RPM		1350

STEERING

Full power hydrostatic system utilising the main hydraulic pump via a steering priority valve. In the event of engine failure, emergency steering is maintained.

Machine model	3CX Contractor
Axles	Steer drive
Steering turns – lock to lock	2¾
	m (ft-in)
Kerb – kerb turning circle – unbraked	8.1 (26-7)
Kerb – kerb loader clearance circle – unbraked	10.4 (34-1)
Turning circle – braked	6.9 (22-8)
Loader clearance circle – braked	9.5 (31-2)

(Depending on tyre size, ground conditions etc.)

ENGINE SUPPORT SYSTEM

Engine support system is designed for ease of daily checks, routine maintenance and longer service intervals.

Fuel type	Diesel.
Fuel filter	Replaceable spin-on cartridge plus water/sediment separator.
Air cleaner	Dual, dry element cyclonic type.
Oil filter and lubrication	Full flow, spin-on type filter.
Cooling system	Hot climate specification, pressurised 14.5 psi (1.0 bar) suction fan. Pressurised recovery tank with integral filler neck.

ELECTRICAL AND INSTRUMENTATION

12 volt negative ground, utilising wiring and connectors meeting IP69 water ingress test standard. Central fuse panel supplemented with main circuit breakers at battery positive terminal.

Gauges	Tachometer, engine coolant temp, fuel level, hourmeter, clock.
Warning system	Audible and visual system for engine oil, transmission, park brake, battery, air cleaner, alternator.
Battery	115 A/hr.
Pre-wire	Radio speakers (cab), beacon (all).
Horn	Controlled from both front and rear.
Alternator	75 amp (85 amp option).
Front working lights	2 twin beam fixed position.
Rear working lights	4 adjustable.



JCB BACKHOE LOADER | 3CX CONTRACTOR



TRANSMISSION

The JCB Transmissions are designed and built specifically for JCB Backhoe Loaders. They feature synchronised shifting in all gears. Powershuttle between forward and reverse. Ground speeds are designed to maximise production. JCB auto powershift 6 speed transmission features automatic upshift and downshift between 4th, 5th and 6th gear controlled by machine travel speed and incorporates a kickdown pedal to select first gear. The operator may use the Autoshift in manual mode when operator control of shift points is desired. The JCB Powershift transmission allows fast gear changing without losing speed or momentum on gradients. The integral torque converter and electrically operated reversing shuttle help this backhoe loader produce fast cycle times for real wheeled loader performance. Low 1st and 2nd gear ratios provide excellent tractive effort for loading and sitestripping.

Machine model	3CX Contractor	3CX Contractor
Manufacturer	JCB Powershift	JCB Auto Powershift option
Type	Powershift	Automatic Powershift
Torque converter	305mm (12")	305mm (12")
Torque converter ratio	2.54:1	2.54:1
Gears forward/reverse	4/4	6/4
Gear selection	Powershift	Powershift
Shuttle control – F/R	Power shuttle	Power shuttle
Travel speeds	kph (mph)	kph (mph)
Tyres equipped – front 12.5x18 rear 18.4x26		
Gear 1	5.2 (3.2) F / 5.2 (3.2) R	5.09 (3.1) F / 6.3 (3.9) R
Gear 2	9.6 (5.9) F / 9.6 (5.9) R	8.4 (5.2) F / 8.5 (5.4) R
Gear 3	22.3 (13.8) F / 22.3 (13.8) R	11.3 (7.0) F / 22.4 (14.4) R
Gear 4	41.5 (25.7) F / 41.5 (25.7) R	18.0 (11.4) F / 29.9 (19.7) R
Gear 5	–	29.3 (19.0) F / –
Gear 6	–	38.3 (25.5) F / –

FRONT AXLE

JCB front axles are designed and built specifically for backhoe loaders and accept a wide variety of tyre combinations.

Machine model	3CX Contractor
Type	JCB 4WD steer drive with torque proportioning
Axle ratings	kg (lb)
Static load rating	16500 (36375)
Dynamic load rating	5500 (12125)
Oscillation angle	16°
Steering ram	Powered track rod

REAR AXLE

JCB rear axles are designed and built specifically for backhoe loaders and accept a wide variety of tyre combinations.

Machine model	3CX Contractor
Type	JCB Epicyclic hub reduction with torque proportioning
Limited slip	Option
Axle ratings	kg (lb)
Static load rating	21000 (46296)
Dynamic load rating	7000 (15432)

CAB

Excellent visibility (and safety) is provided by the extra large tinted glass areas of 6.4 sq m (70 sq ft). Cab frame is ROPS and FOPS approved for maximum operator protection. ISO standard 3471 and 3449 (SAE J1040 and J231).

- A fully adjustable seat with lumbar support combines with ergonomically positioned controls to minimise operator fatigue.
- The in-cab noise levels are the lowest in the business for maximum operator comfort.
- A radio location is provided as standard plus twin speakers for stereo sound.
- Cab provides easy access through either a single door or two door frame. Rear side windows open either partially or fully for extra ventilation. Standard features include: lap seat belt, 3 speed fresh air/recycle heater, front and rear screen wash/wipers, front and rear horn, exterior mirrors, and flat easy-clean floor.
- The instrument panel is positioned to the right-hand side for ease of viewing from either the loading or excavating position and has an optional lockable cover for vandal proofing. Engine speed, fuel and coolant temperature gauges, (and clock on cab builds) are mounted in the panel.
- A high performance air conditioning system is optionally available on turbo builds providing the operator with a cool working environment when working in high temperatures.
- Static or mechanical suspension seat gives the operator a comfortable operating position.
- An optionally available heated air suspension seat gives the operator the ultimate comfort with automatic compensation for weight.

JCB PRECISION CONTROL (Optional)

JCB Precision Control backhoe and loader controls offer smooth, low effort and productive operation while reducing operator fatigue. Excavator control joysticks are integrated into the seat armrests, which provides increased legroom, improved job visibility and hydraulic excavator ergonomics. The pilot loader joystick is a separate set of levers, simulating the traditional manual levers, with JCB's unique shadowing auxiliary lever providing unmatched feel and control.

Best in class hydraulic modulation combined with the greatest digging performance, means that the JCB Precision Control is unmatched in any backhoe loader.



JCB BACKHOE LOADER | 3CX CONTRACTOR



LOADER DIMENSIONS

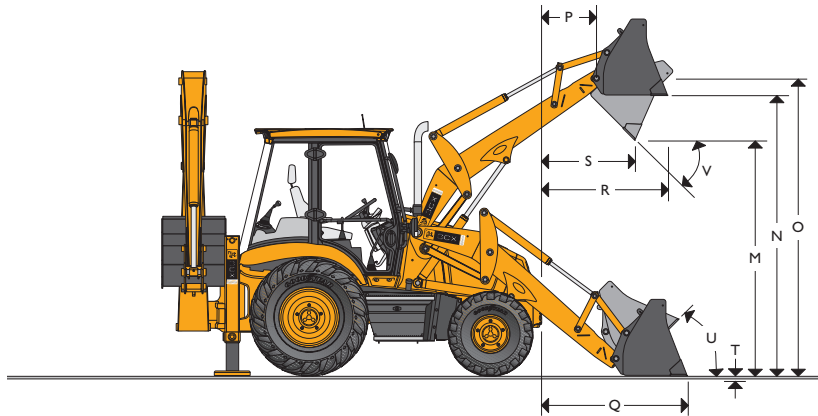

LOADER ATTACHMENTS

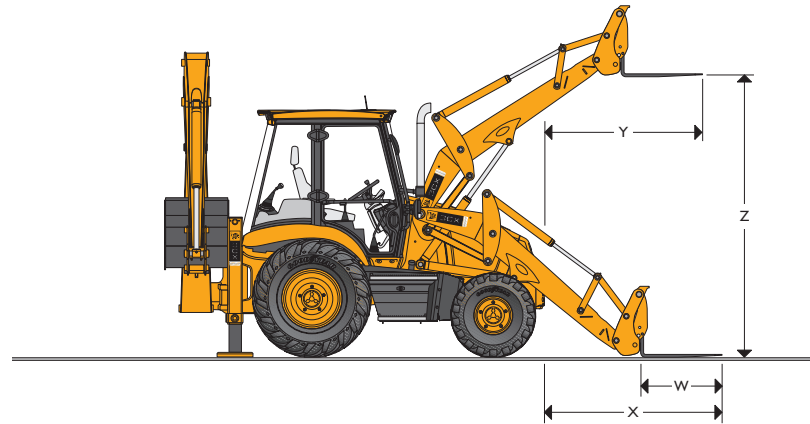

LOADER DIMENSIONS – 6-in-1 Shovel

	m (ft-in)
M Dump height	2.74 (9-0)
N Load over height	3.20 (10-6)
O Pin height	3.45 (11-4)
P Pin forward reach	0.36 (1-2)
Q Reach at ground (toe plate horizontal)	1.37 (4-6)
R Max. reach at full height	1.15 (3-9)
S Reach at full height fully dumped	0.78 (2-7)
T Dig depth	0.10 (0-4)
U Rollback at ground	45°
V Dump angle	43°
Jaw opening width	0.95 (3-1)

LOADER ATTACHMENTS – Forklift Performance and Data

	6-in-1 Shovel mounted forks	Quickhitch mounted forks
	m (ft-in)	m (ft-in)
Section width	0.08 (0-3 ¹ / ₈)	0.08 (0-3 ¹ / ₈)
W Fork length	1.1 (3-7)	1.1 (3-7)
X Reach at ground	2.66 (8.9)	2.03 (6-8)
Y Reach at full height	2.25 (7-5)	1.72 (5-8)
Z Fork lift height	2.92 (9-7)	3.27 (10-9)
Fork spacing – min	0.2 (0-8)	0.2 (0-8)
Fork spacing – max	2.17 (7-3)	1.03 (3-4)
SWL @ 500mm load centres	kg (lb) 1000 (2205)	2000 (4410)

LOADER ATTACHMENTS – Direct Mount

Loader buckets are listed according to size and application. All buckets are drilled to accept optional auxiliary cutting edge or teeth. Flat top box section provides rigidity and assists in bucket levelling.

6-in-1 Shovel		
Width mm (ft-in)	Capacity SAE	
	Rated m ³ (yd ³)	Struck m ³ (yd ³)
2235 (7-4)	1.0 (1.32)	0.83 (1.09)
2350 (7-8)	1.0 (1.32)	0.83 (1.09)

LOADER PERFORMANCE

JCB loaders provide parallel lift self levelling on the up and down cycle enhancing load retention and use of optional pallet forks. High capacity buckets combined with high lift and breakout forces maximise productivity.

Machine model		Standard lift rams	Large lift rams option
Loader breakout of shovel	kgf (lbf)	6500 (14340)	6500 (14340)
Loader breakout – arms	kgf (lbf)	4850 (10690)	5577 (12297)
Lift capacity to full height – A*	kg (lb)	2850 (6270)	3591 (7918)
Lift capacity to full height – B*	kg (lb)	2800 (6160)	3528 (7780)
Clamping force (A* and B*)	kgf (lbf)	2940 (6480)	2940 (6480)

* Type A shovel = 2235mm (7'4") / Type B shovel = 2350mm (7'8")



JCB BACKHOE LOADER | 3CX CONTRACTOR



BRAKES

The JCB braking system ensures effective, fade-free braking. The self-adjusting, multi-disc arrangement is inboard mounted and is oil immersed for minimum maintenance and a long operating life.

- A 3 position switch allows the selection of 2 wheel drive with two wheel braking; 2 wheel drive with four wheel braking or 4 wheel drive with four wheel braking.
- All machines are fitted with servo assisted brakes as standard for low effort braking.
- Twin brake pedals provide tighter turning circle and enhanced steering control on slippery ground.
- Automatic compensation ensures 'straight' machine braking.
- Disc diameter: 220 mm (8.7 in). Friction area: 129,000 sq.mm (200 sq. in) per brake.
- The independent parking brake is mounted on the input shaft of the rear axle and will hold the machine on 1:3 gradients. It is an over-centre type, adjustable within the cab, with transmission disconnect to prevent premature brake pad wear. Park brake disc diameter: 280 mm (11 in). Friction area: 5416 sq.mm (8.4 sq. in).

TYRES

Front	12.0 x 18, 10PR Industrial 12.5 x 18, 10PR Industrial 16/70 x 20, 10PR Traction or Industrial
Rear	18.4 x 26, 12PR Traction or Industrial 16.9 x 28, Radial Traction

SMOOTH RIDE SYSTEM (Optional)

The JCB Smooth Ride System (SRS) consists of a dry nitrogen and oil filled accumulator installed in line with the loader lift cylinders. When activated, the Smooth Ride System allows the loader arms to float. This action counteracts variations in road or site surfaces and provides the operator with a smooth ride.

Activation Electric switch on instrument panel. Manually controlled by the operator for maximum benefit and user flexibility.

JCB POWERSLIDE

Exclusive to JCB, this option enables the excavator's sideshift carriage to be hydraulically powered across the rearframe by the operation of a pedal in the cab.

With this feature there is no need to "push" the carriage across with the bucket avoiding ground damage and the need to relocate the whole machine.

HYDRAULIC SYSTEM

The Open Centre system uses twin gear pumps and Hydraulic Speed Control (HSC) with a power modulation valve that automatically varies hydraulic power to match digging conditions for extra performance and power.

- Open centre hydraulic system using simple and reliable high efficiency gear pumps.
- A Power Modulation Valve automatically varies the hydraulic power to match digging conditions to improve performance and efficiency – automatically dumps one pump when 4th gear selected on powershift models.
- The HSC switch enables controlled use of hydraulic response depending upon application.
- Easily used, ergonomically positioned levers give excellent control of the loader and backhoe, thus reducing operator fatigue.
- An independent pump powers the Extradig dipper so that it can extend or retract without breaking the digging cycle. This allows faster cycle times and simultaneous use of the telescopic and normal excavator actions in operations such as grading and bank dressing.
- A full flow 10 micron filter ensures that oil stays free of contaminants.

Engine	Turbo
Pump flows at 2200rpm	l/min (gal/min)
Main pump output	90 (20)
Second pump output	57 (12.5)
System working pressure	bar (lbf/sq in)
Backhoe and loader	227 (3300)

SERVICE CAPACITIES

Machine model	3CX Contractor
	ltr (gal)
Cooling system	23 (5)
Fuel tank	160 (34.5)
Engine oil with filter	10 (2.2)
Powershift transmission with filter	16 (3.5)
JCB auto powershift	16 (3.5)
Rear axle	16 (3.5)
Front drive axle	16 (3.5)
Hydraulic system incl. tank	132 (29)



JCB BACKHOE LOADER | 3CX CONTRACTOR



BACKHOE BUCKETS – Standard Profile Bucket

JCB backhoe buckets are designed specifically for use on JCB machines with pin positions to maximize tearout, load retention and straight wall digging characteristics.

Width*	Capacity SAE		Weight (+ teeth)	
	Rated m ³ (ft ³)	Struck m ³ (ft ³)	kg (lb)	Teeth
305 (12)	0.06 (2½)	0.05 (1¾)	102 (225)	3
400 (16)	0.09 (3)	0.07 (2½)	109 (240)	3
457 (18)	0.12 (4¼)	0.09 (3)	116 (256)	3
610 (24)	0.17 (6)	0.13 (4½)	140 (310)	4
800 (32)	0.24 (8½)	0.17 (6)	162 (355)	5
950 (37)	0.30 (10½)	0.21 (7¼)	198 (435)	5

* Including sidecutters. Width less sidecutters deduct 25mm (1in).

BACKHOE BUCKETS – Deep Profile Bucket

Width*	Capacity SAE		Weight (+ Teeth)	
	Rated m ³ (ft ³)	Struck m ³ (ft ³)	kg (lb)	Teeth
305 (12)	0.09 (3)	0.07 (2½)	102 (225)	3
457 (18)	0.16 (5½)	0.13 (4½)	122 (269)	3
610 (24)	0.23 (8)	0.18 (6¼)	142 (314)	4
800 (32)	0.30 (10½)	0.24 (8½)	163 (359)	5
950 (37)	0.38 (½)†	0.30 (10½)	183 (403)	5
1100 (43)	0.48 (¾)†	0.34 (12)	203 (448)	6

* Including sidecutters. Width less sidecutters deduct 25mm (1in). † Capacity in cu.yd.

BACKHOE DIMENSIONS

		m (ft-in)
A SAE max dig depth	Ext	5.46 (17-11)
	Ret	4.24 (13-11)
SAE 2ft flat bottom	Ext	5.43 (17-10)
	Ret	4.21 (13-10)
Maximum dig depth with deep profile bucket	Ext	5.97 (19-7)
	Ret	4.75 (15-7)
B Reach – ground level to rear wheel centre	Ext	7.87 (25-10)
	Ret	6.72 (22-1)
C Reach – ground level to slew centre	Ext	6.52 (21-5)
	Ret	5.37 (17-7)
D Reach – at full height to slew centre	Ext	3.66 (12-0)
	Ret	2.74 (9-0)
E Side reach – to centre line of machine	Ext	7.09 (23-3)
	Ret	5.94 (19-6)
F SAE operating height	Ext	6.35 (20-10)
	Ret	5.53 (18-2)
G Maximum loadover height	Ext	4.72 (15-6)
	Ret	3.84 (12-7)
SAE loadover height	Ext	4.32 (14-2)
	Ret	3.44 (11-3)
H Total kingpost travel		1.16 (3-10)
	Narrow rear frame option	1.05 (3-5)
J Bucket rotation	Speed	201°

BACKHOE PERFORMANCE

		kgf (lbf)
Bucket tearout	Speed	4940 (10870)
	Power	5700 (12540)
Dipper tearout – standard lift excavator	Ext	2085 (4590)
	Ret	3010 (6620)
Dipper tearout – heavy lift excavator	Ext	2515 (5550)
	Ret	3635 (8010)
		kg (lb)
Lift capacity of bucket pivot at full reach – standard lift excavator	Ext	990 (2180)
	Ret	1250 (2750)
Lift capacity of bucket pivot at full reach – heavy lift excavator	Ext	1245 (2740)
	Ret	1580 (3470)



JCB BACKHOE LOADER | 3CX CONTRACTOR

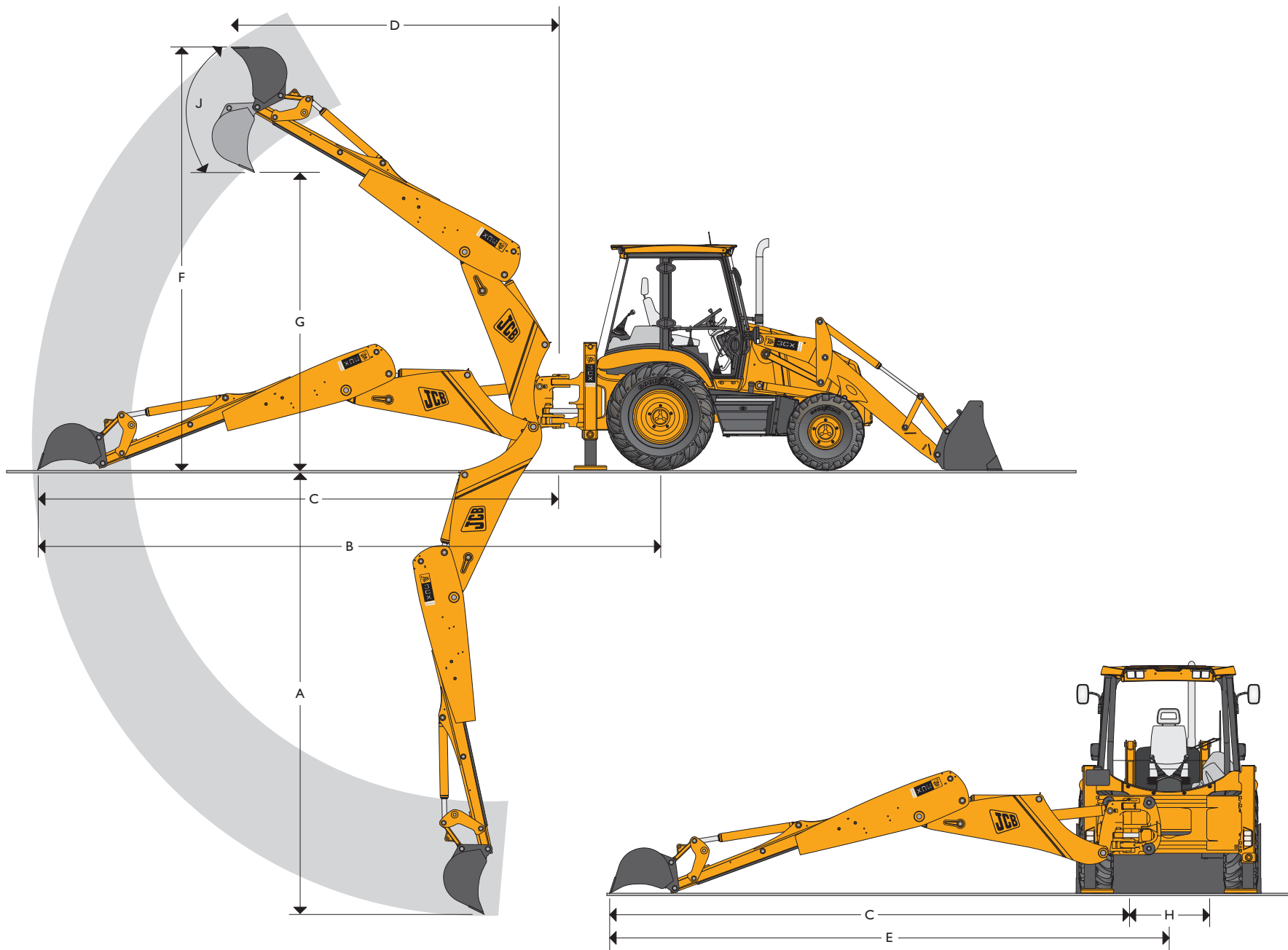



A GLOBAL COMMITMENT TO QUALITY

JCB's total commitment to its products and customers has helped it grow from a one-man business into Britain's largest privately owned manufacturer of backhoe loaders, crawler excavators, wheeled excavators, telescopic handlers, wheeled loaders, dump trucks, rough terrain fork lifts, industrial fork lifts, mini/midi excavators, skid steer loaders and tractors.

By making constant and massive investments in the latest production technology, the JCB factories have become some of the most advanced in Europe.

By leading the field in innovative research and design, extensive testing and stringent quality control, JCB machines have become renowned all over the world for performance, value and reliability.

And with a global sales and service network of over 400 distributors and agents, the company exports over 70% of its production to all five continents.

Through setting the standards by which others are judged, JCB has become one of Britain's most impressive success stories.

