

Contents	Page
General Information	2
Emission rates	2
Dimensions	2
Quick sizing charts	3
Safe Handling	3
Connections	4

General information

Manufacturing standards

Clyde Bohemia radiators are manufactured and supplied in accordance with BS EN 442-1:1995. As required by this Standard, emission rates are quoted for the standard thermal output of $\Delta T=50$ (75/65/20°C) with the relevant exponent of excess temperature.

Heat emission rates

For convenience the emission rates are also quoted for traditional United Kingdom applications of $\Delta T=55.5$ (82/71/21°C) and $\Delta T=60$ (90/70/20°C). For condensing boiler applications, the base emission rates at $\Delta T=50$ may be more appropriate.

Different water and/or room temperatures will change the emission rate of the radiator. The method of calculation and correction factors for various temperatures are given in Clyde's radiator emission guide EDS 732, available on request.

The emission rates stated are all based upon TBOE (top & bottom opposite end) connections.

Application

Clyde Bohemia radiators are suitable for use in either open vented or sealed heating systems with a maximum operating pressure of 6 bar.

Materials

Bohemia radiators are manufactured from grey cast iron complying with ISO 185 by an ISO 9001 Quality Registered source. They are supplied as fully-assembled blocks in a pewter paint finish (WECO-FAN 9007).

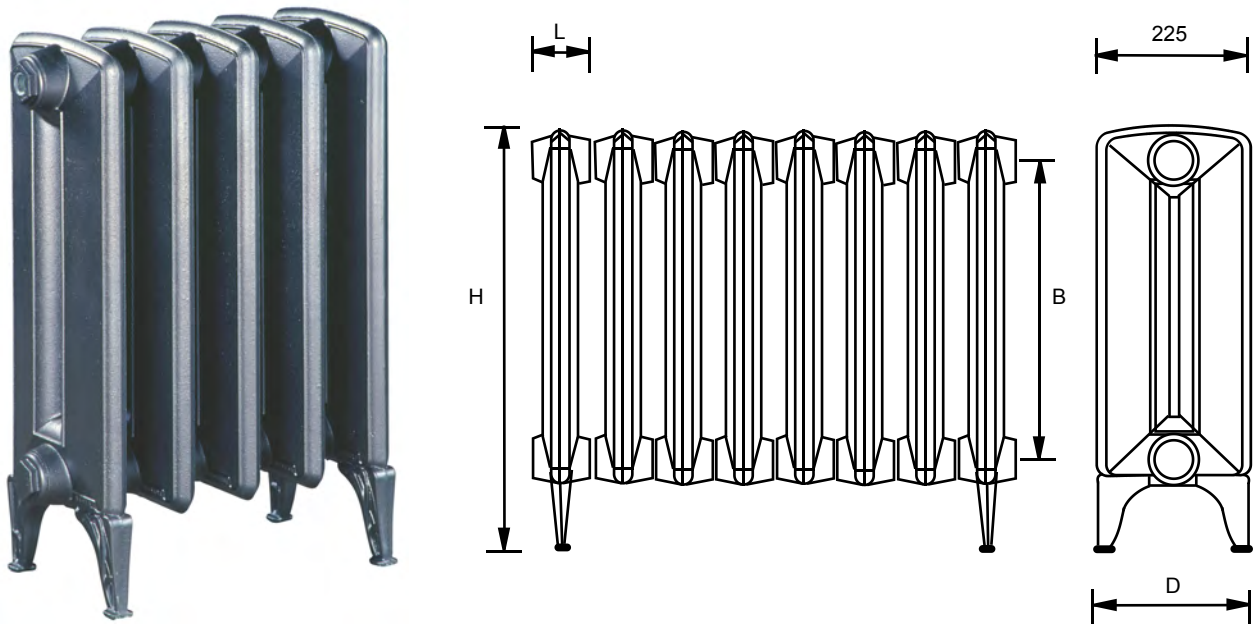

Section emission rates and technical data

Model	BS EN 442 75/65/20°C $\Delta T50$		Emission rates		Recommended Max. No. sections	Overall Length ★ L mm	Overall height H mm	Section details		Dry weight kg	Water content litres
	watts	Exponent	82/71/21°C $\Delta T55.5$ watts	90/70/20°C $\Delta T60$ watts				Bore centres B mm	Depth D mm		
B450/220	111.0	1.30	127.0	141.0	19	90.0	640	450	238	13.2	1.3

★ Overall section length = section + joint ring

SI conversion factor : 1 watt = 3.412 Btu/h

Quick sizing chart & safe handling

Model	Number of sections											
	4	5	6	7	8	9	10	11	13	15	17	19
	Output at ΔT 50											
450/220	444	555	666	777	888	999	1110	1221	1443	1665	1887	2109
	Output at ΔT 55.5											
450/220	508	635	762	889	1016	1143	1270	1397	1651	1905	2159	2413
	Output at ΔT 60											
450/220	564	705	846	987	1128	1269	1410	1551	1833	2115	2397	2679

Stated outputs are in Watts

Radiator blocks

Radiator blocks consist of footed sections and intermediate sections. Blocks of up to 10 sections consist of 1 footed section at each end and up to 8 intermediate sections. Blocks of more than 10 sections require an additional footed section in the middle, and so are supplied in odd numbers.

Packing, handling & site work

Radiator sections are supplied on pallets to facilitate handling. They are delivered as prepared blocks, so no site assembly is required.

Any accessories (see page 4) are delivered packed separately for fitting by the installer. It is important that radiators are protected from the elements during offloading and are stored in dry and adequately heated premises. After radiators have been removed from their pallets, they must be kept vertical whilst being carried to their installation locations to avoid damage to the section joints.

Safe handling

Cast iron radiators are heavy. Always provide sufficient manpower to make carrying safe. Incorrect handling of radiator blocks can cause water leaks from section joints. Lift the radiator blocks in the centre to bring them to the vertical position before lifting and carrying. Never carry radiators stretcher fashion.

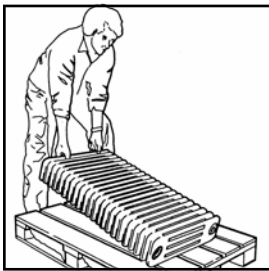

DO NOT !
Lift from one end

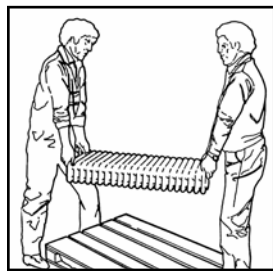

DO NOT !
Carry radiators flat

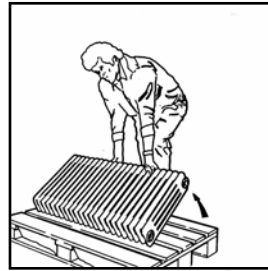

Always !
Lift in centre

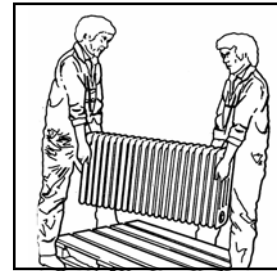

Always !
Keep sections vertical



Guarantee

Subject to correct handling, installation, water treatment and operation, Clyde Bohemia radiators are guaranteed for 10 years from date of despatch.

The guarantee is not valid if the radiator sections become blocked with debris and/or carbonate deposits from the heating system or for leakage from connection joints that are not factory assembled.

System water must be treated with an approved additive to remove dissolved oxygen and control the pH value.



Connections

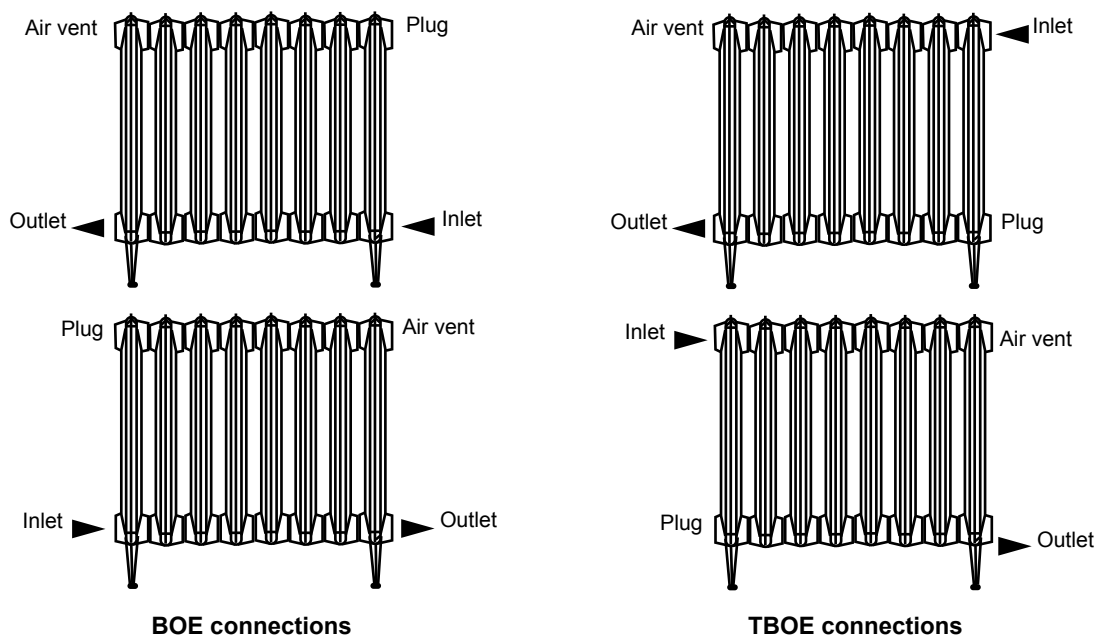

Connections

A set of connection fittings and joint rings is provided for each radiator. Each set comprises :

- 2 x Rp1¼ x Rp½ pipe connection bushes 1 x Rp1¼ plug (RH thread)
- 1 x Rp1¼ vent bush (LH thread) and Rp½ vent valve.

As standard, radiators are supplied with the above fittings for BOE (bottom opposite end) connection. If TBOE (top & bottom opposite end) connection and / or Rp¾ pipe connection bushes are required, these are supplied as an additional fittings pack.

The vent valve should always be fitted at the outlet end of the radiator. If necessary, rotate the radiator to position the vent correctly.



Units 13-14 Charlwoods Road
East Grinstead, West Sussex, RH19 2HU
t. 01342 305550 f. 01342 305560
www.clyderadiators.co.uk

Illustrations and technical data are not binding in detail, all measurements and outputs are in accordance with the manufacturer's terms of reference at the time of going to press. Please refer to current EDS documents for technical specifications prior to ordering.