



**FRANCIS PLUMBING & HEATING  
CLIMATECARE.**

## DUAL FIRED APPLIANCE



### DC Series

Dual Fired Appliance  
Certified as a Boiler & Water Heater

<b>DC 15-96</b>	15,000 to 96,000 BTU/HR
<b>DC 20-125</b>	20,000 to 125,000 BTU/HR
<b>DC 33-160</b>	33,000 to 160,000 BTU/HR



**Unique 2 in 1 heat exchanger eliminates the need for a diverter valve and plate type heat exchanger.**

- Two independent copper coils embedded in a cast aluminium heat exchanger.
- Up to 96% AFUE with full ASME-rated pressure vessel. ANSI Z21.13 / CSA 4.9
- Up to .87 EF. ANSI Z21.10.3 / CSA 4.3.
- Low lead certified.
- PVC/CPVC/PPs approved.
- Built-in pump.
- Self-cleaning, self-draining vertical fin heat exchanger.
- Up to 6.25:1 turndown ratio of better load matching.
- Copper waterways provide stable performance and glycol compatibility.

- Exceptional longevity. Heat exchanger has a 20 year track record, with over 1.5 million installed.
- Contractor friendly, fewer internal parts, easy to install, maintain and service.
- Outdoor reset technology increases efficiency by lowering the water temperature automatically.
- Includes Air Vent, Outdoor Sensor & Relief Valve.
- 5 year limited manufacturer's parts warranty.
- 10 year limited heat exchanger warranty.



**IBC Better Boilers**



**Better Boilers**

# DC Series

15,000 to 96,000 BTU/HR  
20,000 to 125,000 BTU/HR  
33,000 to 160,000 BTU/HR

## Dual Fired Appliance



HEIGHT	DC SERIES
DC 15-96	29.0" / 736mm
DC 20-125	31.3" / 796mm
DC 33-160	31.3" / 796mm

DESCRIPTION	DC SERIES
A Exhaust outlet	3" Schedule 40
B Combustion air	3" Schedule 40
C Cold domestic water connection	3/4" Male NPT
D Hot domestic water connection	3/4" Male NPT
E Heating water inlet (return)	1" Male NPT
F Heating water outlet (supply)	1" Male NPT
G Gas inlet	1/2" Male NPT
H Condensate outlet	3/4" Hose
I Knock-outs (3)	1/2"

Connections

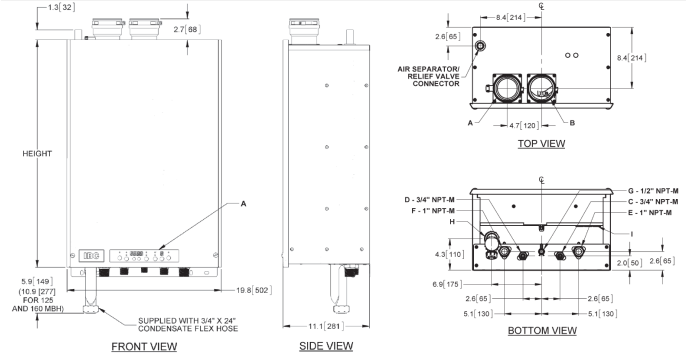

SPECIFICATIONS	DC 15-96	DC 20-125	DC 33-160
CSA Input (Natural Gas or Propane) – MBH	15 - 96	20 - 125	33 - 160
CSA Input (Natural Gas or Propane) – KW	4.4 - 27.8	5.6 - 36.6	9.7 - 46.9
CSA Output – MBH	14.3 - 90.3	18.6 - 110.8	30.4 - 140.0
CSA Output - KW	4.2 - 26.4	5.4 - 32.5	8.9 - 41.0
DHW - CSA Input (Natural Gas or Propane) - MBH	15 - 95	20 - 125	33 - 124
DHW - CSA Input (Natural Gas or Propane) - KW	4.4 - 27.8	95.6 - 36.3	9.7 - 36.3
A.F.U.E	96%	95%	94%
E.F.	.87	N/A	N/A
Min gas pressure (Nat. Gas or Propane) – inch w.c.	5	5	5
Max Gas Pressure (Nat. Gas or Propane) – inch w.c.	14	14	14
Power (120Vac/60Hz) - Watts @ full fire with internal pump	128	130	164
Weight (empty) – lbs/Kg	85 / 39	85 / 39	85 / 39
Pressure vessel water content – USG/Liters	0.37 / 1.4	0.5/1.9	0.5/1.9
Max appliance flow rate - USgpm	10	11	11
Min appliance flow rate - USgpm	3	3	3
Max operating pressure – Space Heating Coil - psig	43.5	43.5	43.5
Max operating pressure – Domestic Hot Water Coil - psig	150	150	150
Approved installation altitude - ASL	0 - 12,000 ft	0 - 12,000 ft	0 - 12,000 ft
Ambient temperature – Low (°F/°C)	32/0	32/0	32/0
Ambient temperature – High (°F/°C)	122/50	122/50	122/50
Max relative humidity (non-condensing)	90%	90%	90%
Min water temperature - Space Heating (°F/°C)	50/10	50/10	50/10
Max water temperature – Space Heating (°F/°C)	194/90	194/90	194/90
Min water temperature – Domestic Hot Water (°F/°C)	104/40	104/40	104/40
Max water temperature – Domestic Hot Water (°F/°C)	149/65	149/65	149/65
Min flow rate to activate DHW heating - USgpm	0.5	0.5	0.5
Max flow rate DHW heating - USgpm	2.6	4	4
Max equivalent vent length 2" (each side)	35'	35'	35'
Max equivalent vent length 3" (each side)	120'	120'	120'
Domestic hot water delivery: @70°F/ 39°C temperature rise	2.3 GPM	3.2 GPM	3.2 GPM

Natural Gas appliances require a Propane conversion kit to be ordered separately if converting from Natural Gas to Propane. Propane appliances require a Natural Gas conversion kit to be ordered separately if converting from Propane to Natural Gas.

DC Series Appliances are shipped with 30 psi pressure relief valve.

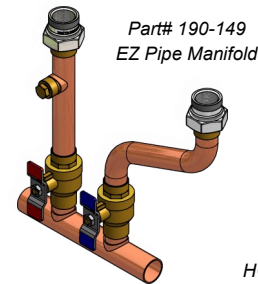

Part# 734  
HC/DC Universal Parts Service Kit

SURFACE	DISTANCE FROM COMBUSTIBLE SURFACES	RECOMMENDED DISTANCE FOR INSTALLATION AND SERVICE
Front	2"	24"
Rear	0"	0"
Left Side	1.5"	6" (labels may be difficult to read with reduced clearance)
Right Side	4"	6" (labels may be difficult to read with reduced clearance)
Top	2"	24"
Bottom	8"	24"

Clearance from boiler cabinet

EXHAUST PIPE SIZE	MAXIMUM EQUIVALENT LENGTH
Sched.40; Rigid PPs	(each side)
2"	35'
3"	120'
2"/ 3" 90° Long sweep vent elbow	Allow 5' equivalent feet
2"/ 3" 90° Short sweep vent elbow	Allow 8' equivalent feet
2"/ 3" 45° Vent elbow	Allow 3' equivalent feet
PPs	
PPs 87-90°Elbow	Allow 8' equivalent feet
Flexible PPs	
3" Flexible	35 Actual feet

Maximum exhaust venting length

As part of our continuous product improvement, IBC reserves the right to change specifications and design without notice.



www.ibcboiler.com

NSF/ANSI 372  
Low Lead Content

Your Local IBC Experts: Francis Plumbing & Heating ClimateCare  
phone: 613-224-0041 email: office@francisplumbing.com  
chat on our website: www.FrancisPlumbing.com

