



Technical information & installation advice

Page 1 of 1

Cavity closers

The Timloc Thermo-loc cavity closer is an insulated cavity closer and DPC which is installed around door and window openings in external walls.

Installation advice

- Can be used in both first and second fix applications
- Cut the cavity closer into required lengths allowing the jamb section to overlap the sill section and to butt the underside of the lintel
- In first fix applications the cavity closer should be nailed to the jamb/sill of the door or window frame and the whole assembly built in as work proceeds. Alternatively the closer can be built in sections using fixing ties as work proceeds or pre built to act as an opening former by using a timber brace (see fig.2a) and corner forms (see fig.2b)
- Fixing ties are available for secure fixing if required (particular attention around door openings). Allow for ties at 450mm centres.
- For second fix applications, the cavity closer is pushed into the open cavity after building work is complete. The compressible nature of the exposed insulation material is used to create a friction fit in the cavity, or alternatively the insulation can be trimmed to fit using a sharp knife
- Joining 'off cut' sections should be kept to a minimum and not carried out to sill sections. Sections are joined by mitre cutting the closer profile to allow the downward cut to run away from the jamb. Insulation should be extended from the lower closer profile to allow this to slot into the upper profile to maintain a rigid section. All overlaps to be tape sealed
- When installed in conjunction with the cavity closer, the back edge of the window/door frames should be set back at least 30mm behind the inner face of the outer leaf to meet thermal requirements (see fig.3) whilst ensuring that the front edge of the frame remains over the outer leaf. (A smaller set-back may be possible if a satisfactory hygrothermal assessment using BRE Information Paper IP/06, shows that thermal requirements are met). The junctions between the wall and the front and back of the window/door frame must be effectively sealed.

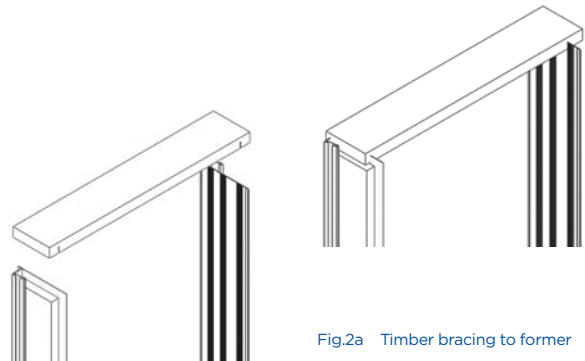

Fig.2a Timber bracing to former

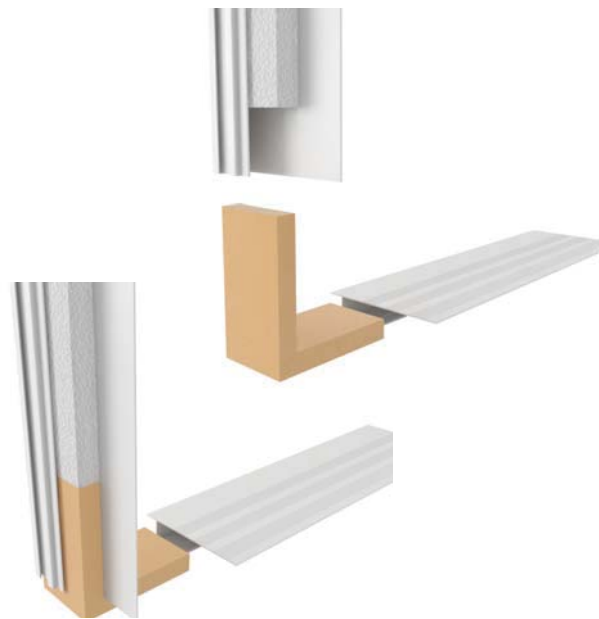

Fig.2b Formed closer using CCFORM

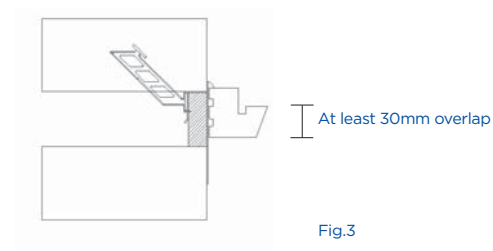

Fig.3