



RAPID-AIR

OPERATING INSTRUCTIONS FOR SA3, SA3M, SB4, SB4M STOCK STRAIGHTENERS

RAPID-AIR
4601 KISHWAUKEE ST.
ROCKFORD, IL. 61109-2925
PHONE: (815) 397-2578
FAX: (815) 398-3887
WEB SITE: www.rapidair.com

TABLE OF CONTENTS

PAGE

1. STRAIGHTENER "HEAD-ONLY" DRAWING
2. INSTALLATION
3. OPERATION
4. TECH. BULLETIN (straightener roll adjustment)
5. KEYPAD FUNCTIONS
6. KEYPAD FUNCTIONS
7. KEYPAD FUNCTIONS
8. JOG SPEED ADJUSTMENT AND DANCER ARM CALIBRATION
9. JOG SPEED ADJUSTMENT AND DANCER ARM CALIBRATION
10. MAINTENANCE
11. TROUBLESHOOTING
12. TROUBLESHOOTING
13. SA3/SA3M CABINET ASSEMBLY DRAWING
14. SB4/SB4M CABINET ASSEMBLY DRAWING
15. SA3 HEAD ASSEMBLY DRAWING (sheet 1 of 2)
16. SA3 HEAD ASSEMBLY DRAWING (sheet 2 of 2)
17. SA3M HEAD ASSEMBLY DRAWING (sheet 1 of 2)
18. SA3M HEAD ASSEMBLY DRAWING (sheet 2 of 2)
19. SB4 HEAD ASSEMBLY DRAWING (sheet 1 of 2)
20. SB4 HEAD ASSEMBLY DRAWING (sheet 2 of 2)
21. SB4M HEAD ASSEMBLY DRAWING (sheet 1 of 2)
22. SB4M HEAD ASSEMBLY DRAWING (sheet 2 of 2)
23. WIRING DIAGRAM

STRAIGHTENER "HEAD-ONLY" DRAWING

(SA3 STRAIGHTENER SHOWN)

MODEL	MAX. MATERIAL WIDTH	Effective Straightening Range	Max. Speed in./min.	AC Input Power Required
SA3	3"	.002-.030" (.051-.76mm)	700" (1778cm)	1/4hp, 115vac, 1ph
SA3M	3"	.002-.030" (.051-.76mm)	1400" (3556cm)	1/2hp, 115vac, 1ph
SB4	4"	.003-.050" (.076 -1.27mm)	825" (2100cm)	1/2hp, 115vac, 1ph
SB4M	4"	.003-.050" (.076 -1.27mm)	1650" (4200cm)	1/2hp, 115vac, 1ph

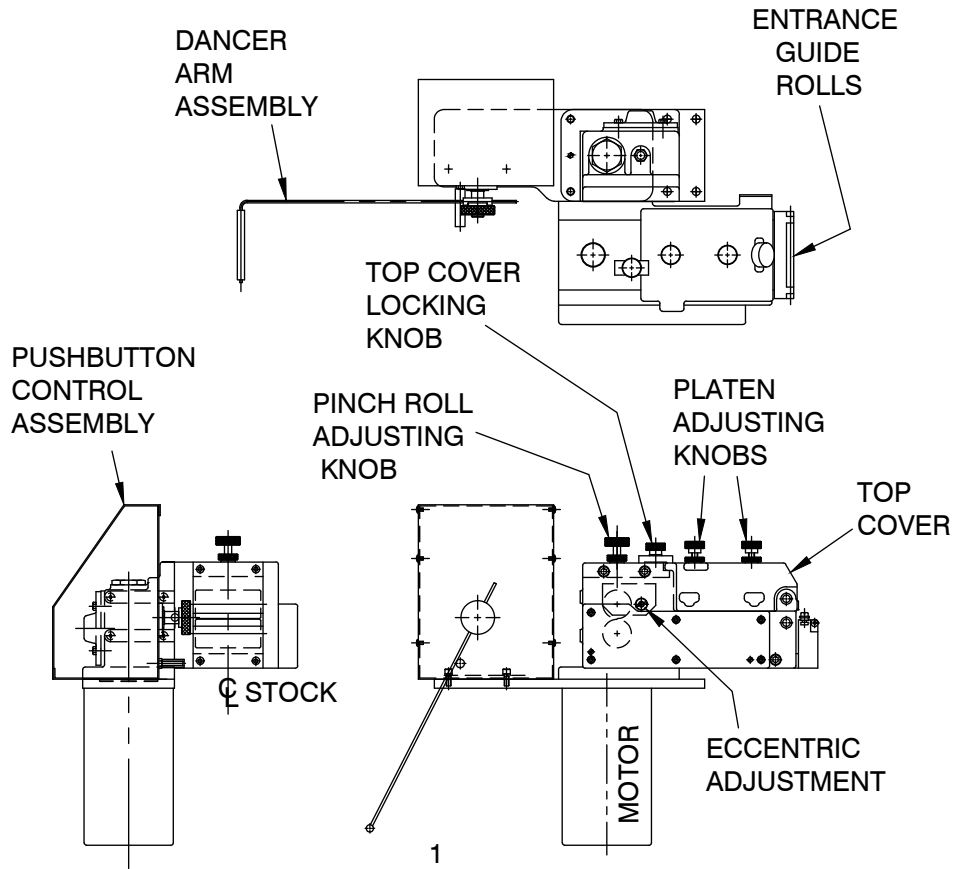

INSTALLATION

1. Your straightener is fully assembled and ready to be put into position. Visually inspect unit for damaged or loose parts due to shipment. If there is physical damage contact carrier.
2. Install your straightener on a level surface with sufficient clearance for loading material and adjusting the roller pressure for straightening. Align and center your unit to the device that will be supplying the stock. For safe operation, bolt unit to the floor. Before bolting your unit to the floor, check for the longest feed length and position your straightener so that there will be about two or three feed lengths in the storage loop without re-inducing coil set in the material.
3. Before inserting material into your straightener, turn on the main power button and run a test cycle using the jog button. Also run a test cycle in the run mode using the dancer arm to test that the speed varies if using the proportional control. Test all other electrical features before continuing.
4. Once these tests have been completed and all the functions are working properly, your straightener can now be used for what it was designed to do and that is to remove coil set.

CAUTION - Disconnect electrical power before performing any service to this machine.

OPERATION

1. Retract the upper pinch roll and upper idler roll platen to a position so that when the cover is closed the material is not being deformed. Open the cover of the straightener and position the edge guides for the maximum width. Cut and place about a four foot length of material onto the straightener rolls with the exit end of the material extending through the exit pinch rolls and centered from side to side in the straightener. Close the cover and latch it. Adjust the exit pinch roll enough to grip and hold the material. Adjust the edge guides so that they just touch the material.
2. Adjust upper idler roll platen (using platen adjusting knobs) to remove coil set. Most of the coil set should be removed with the roller closest to the entrance end of the straightener with declining adjustment as material passes through the rollers closest to the exit end of the straightener. Never overwork the material to the point where opposite coil set is established.
3. Depending on the amount of coil set in your material and the type of material you are trying to straighten, you may be required to run the material through the straightener several times with several adjustments before the required results are achieved.
4. Refer to the Tech. Bulletin on page 4 in this manual for material straightening procedures.

KEYPAD FUNCTIONS

Prior to applying power to your straightener the operator should review all controls on this machine. See pages 5-6 in this manual for a summary of these controls.

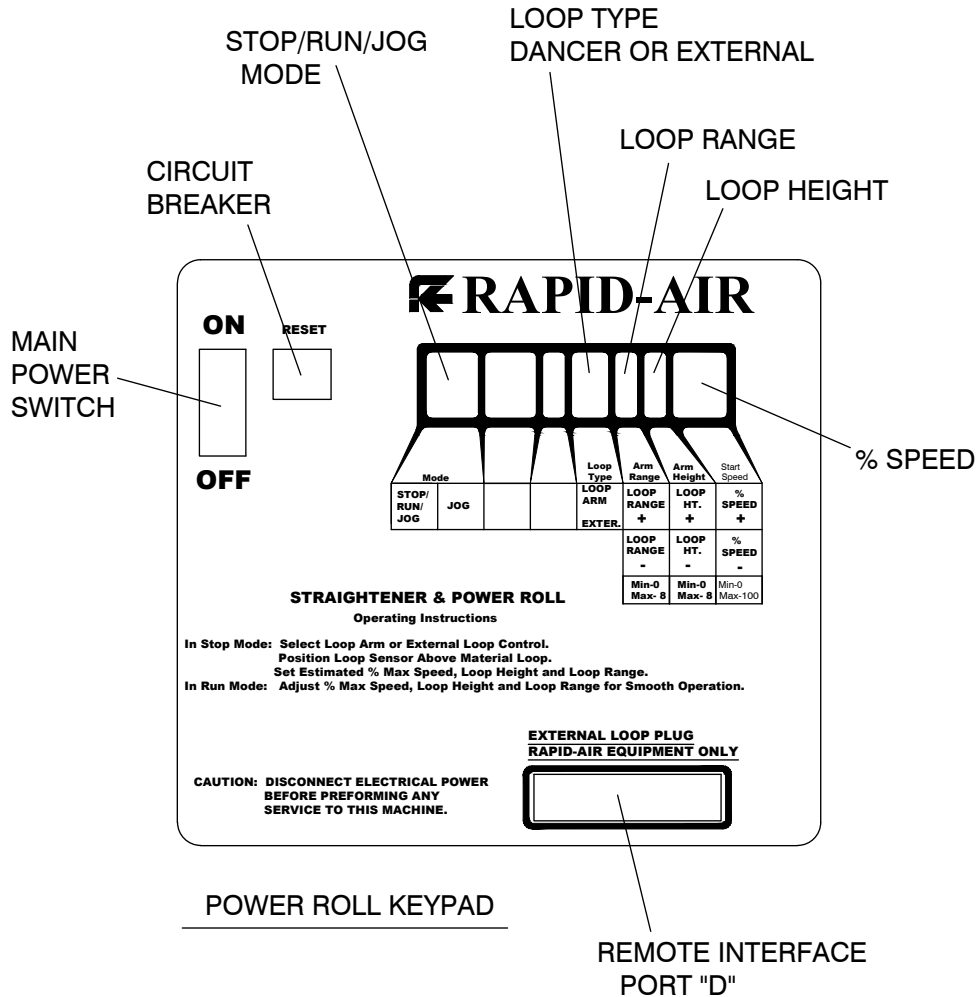

KEYPAD FUNCTIONS

On/Off switch

This illuminated switch is the main power switch for the controller. It must be "ON" for the straightener to function.

Reset switch

This is the main circuit breaker for the straightener.

Run/Stop/Jog

In the Run mode, if the dancer arm is moved the pinch rolls and lower straightening rolls will turn.

In the Jog mode, the jog button has to be depressed for the rolls to turn. Jog function is used mainly for setup.

In the Stop mode there is no movement of the rolls.

Loop arm/external switch

When using a dancer arm, select loop arm button to display "LV" for vertical. This button will also allow you to select "LH" for horizontal. ("LH" is used for Pallet Master decoilers only)

When using an external loop control, select external loop to display "RT" for RTB or "RS" for RS2.

Note: Remote interface port "D" connector, if used, communicates with external loop control.

Warning! - Never plug any type of computer or non Rapid-Air equipment into this plug or severe damage will result. Consult factory when installing new external controls.

KEYPAD FUNCTIONS

Loop range/height

The loop range function selects the degree of arm movement to achieve maximum motor speed. If a loop range of "0" was selected the the arm would only have to travel approximately 6° to have the straightener at full speed. If a loop range of "8" was selected the arm would travel approximately 60° to have the straightener at full speed. This function is active in the "RUN" mode.

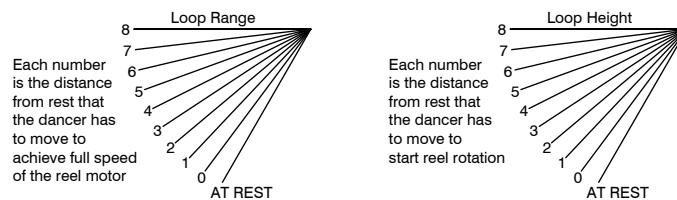

The loop height function selects the degree of arm movement to start roll rotation. If a loop range of "0" was selected the the arm would only have to travel approximately 6° to start roll rotation. If a loop range of "8" was selected the arm would travel approximately 60° before starting roll rotation.

To set the loop height, thread up the material with the dancer arm resting on the material. If the straightener is running with the dancer arm in this position adjust the loop height until straightener stops. This is your new at rest position. This function is active in the "RUN" mode.

% Speed setting

The % speed setting allows you to adjust the maximum speed the rolls will rotate. This should be set to maintain a constant feed rate. This function is active in the "RUN" mode.

JOG SPEED ADJUSTMENT & DANCER ARM CALIBRATION

Your straightener was shipped with the dancer arm set up for it's correct position so the only thing that has to be reset would be the jog speed if you need your unit to jog faster or slower.

To reset the jog speed, turn off the main power switch. Press and hold the "Run/Stop/Jog" button while turning the main power switch on. The first screen you will see will display the jog speed percentage.

JOG SPEED	23%	+
NEXT		-

To increase the jog speed, press the "Start Speed" pushbutton. If you want to decrease the jog speed press the "Start Speed" pushbutton.

% SPEED +

% SPEED -

The jog speed is shown in the percent of maximum jog speed. Once you have set the desired jog speed push the "Run/Stop/Jog" button once for next. Your jog speed is now set.

The next screen asks if you want to set up the sensor (commonly referred to as "dancer arm calibration"). Use the percent speed buttons to select "yes" or "no".

Select "no" if all you wanted to do was change the jog speed, select "yes" if you want to calibrate the dancer arm by resetting the sensor.

SETUP SENSOR	YES
NEXT	NO

After making your selection, press "Run/Stop/Jog" for next.

If you selected "yes" the next screen asks you to set the low set point. If the dancer arm is resting on the positive stop then just save this setting by pushing the "Run/Stop/Jog" button.

SENSOR LOW SETPOINT	
SAVE	xxx

JOG SPEED ADJUSTMENT & DANCER ARM CALIBRATION

The next screen is for setting the high set point. Raise the dancer arm to its upper stop position and press the "Run/Stop/Jog" button once to save this setting.

SENSOR HIGH SETPOINT
SAVE xxx

The next screen is to set the offset of the program. Potentiometers are hard to get set perfectly so we've built in an offset. After setting the high & low points, with the dancer arm resting on the positive stop, put the unit in the "Run" mode. If the unit starts running with the dancer arm on the positive stop then an offset needs to be put in. If an offset needs to be put in go through the setup procedure again until you get to the low offset screen. Using the percent speed buttons put in an offset value of -3 to -5. Press the "Run/Stop/Jog" button to save this setting.

LOW OFFSET +0 +
NEXT -

You now have set the dancer arm limits. The next screen to appear allows you to exit the setup. Use the percent speed button to enter "yes or no".

EXIT SETUP YES
NO

If "yes" was selected press "Run/Stop/Jog" button and the next screen appears.

SHUT OFF POWER TO
SAVE AND EXIT

Power off unit, the dancer arm is now ready for production running.

MAINTENANCE

Gearbox lubrication - change oil every 1000 hours as follows:

Electrical - all brushes on motors should be checked every
1500-2000 hours.

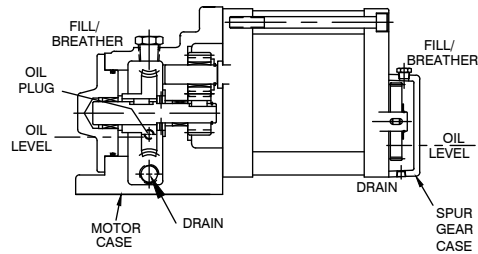

SA3/SA3M STRAIGHTENER

MOTOR CASE	SPUR GEAR CASE
FILL TO OIL PLUG	NO OIL PLUG OR SIGHT
APPROX. 4 oz	APPROX. 4 oz.
MOBIL 600 W	MOBIL 600W

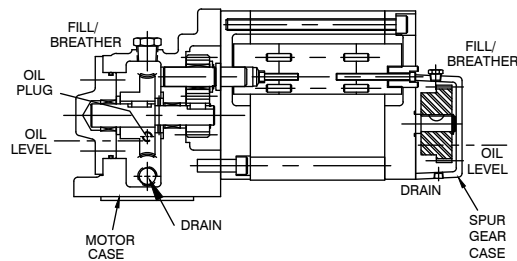

SB4/SB4M STRAIGHTENER

MOTOR CASE	SPUR GEAR CASE
FILL TO OIL PLUG	NO OIL PLUG OR SIGHT
APPROX. 4 oz	APPROX. 6 oz.
MOBIL 600 W	MOBIL 600W

Your straightener was shipped from the factory with the upper & lower pinch rolls parallel to each other. If these pinch rolls should happen to get out of parallel, use eccentric shaft to adjust rolls. See diagram page 1 for location of eccentric shaft. Loosen socket head cap screw in center of shaft. Turn shaft until rolls are parallel with each other. You should be able to grip .001 thick shim stock along entire width of rollers. After adjustment is made, re-tighten socket head cap screw.

TROUBLESHOOTING

MAIN SWITCH ON BUT NOT LIT

1. Circuit breaker tripped
 - a. Reset circuit breaker
2. Unit not plugged into main power
 - a. Plug into main power
3. No power in incoming line
 - a. Check outlet
 - b. Check power cord
4. Loose wiring
 - a. Check terminals and connections

MOTOR CREEPS IN STOP POSITION

1. "Min." speed pot on RAMM board out of adjustment
2. Offset in dancer arm setup out of adjustment (see page 8)

UNIT ON BUT MOTOR WON'T RUN

(armature voltage present on RAMM board)

1. Check motor wiring
 - a. replace motor cord or correct motor wiring (consult factory)
2. Check motor
 - a. Worn brushes or defective motor (consult factory)
 - b. Check for oil in motor, gear box oil seal may have failed

UNIT ON BUT MOTOR WON'T RUN

(no armature voltage present on RAMM board)

1. Selector switch not in "RUN" position
 - a. Turn selector switch to "RUN" position
2. If running with a dancer arm control
 - a. Check that the external/loop arm function is in the loop arm position
3. If running with external control
 - a. Check that the external/loop arm function is in the external position
4. Loop height switch setting to high
 - a. Set height setting to "0"

TROUBLESHOOTING

5. Percent speed function set too low
 - a. Adjust percent speed function to 100%
6. Fuses blown
 - a. Check fuses & circuit breaker
7. No AC voltage at DC drive board
 - a. Check wiring
8. Check signal voltage between P2 to P1 on DC drive
 - 0-6 VDC - RAMM
 - 0-9 VDC - Regen drive
 - while moving dancer arm
 - a. If there is a signal, check continuity between I1 & I2
 - If no continuity, replace DC drive or consult factory
9. Check pico fuse on 69100804 board (F1)
 - a. Replace fuse, 1 amp pico fuse-consult factory

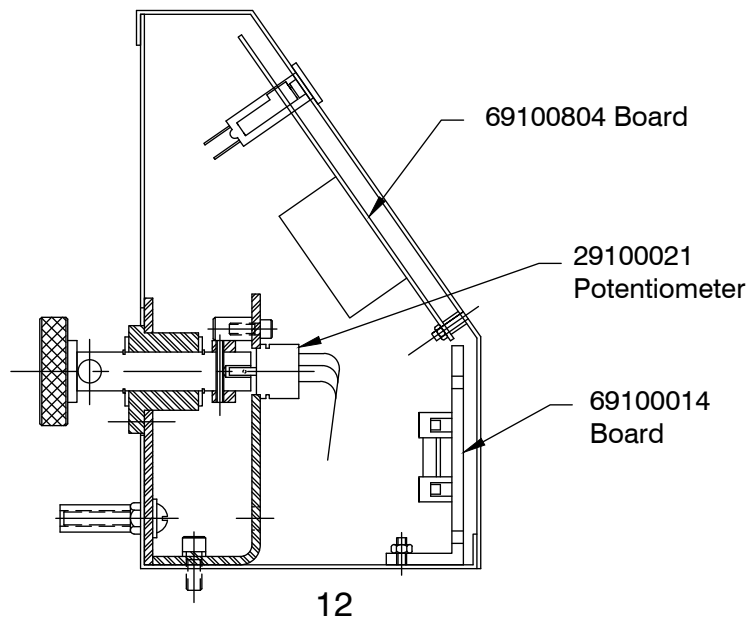

SA3/SA3M CABINET ASSEMBLY

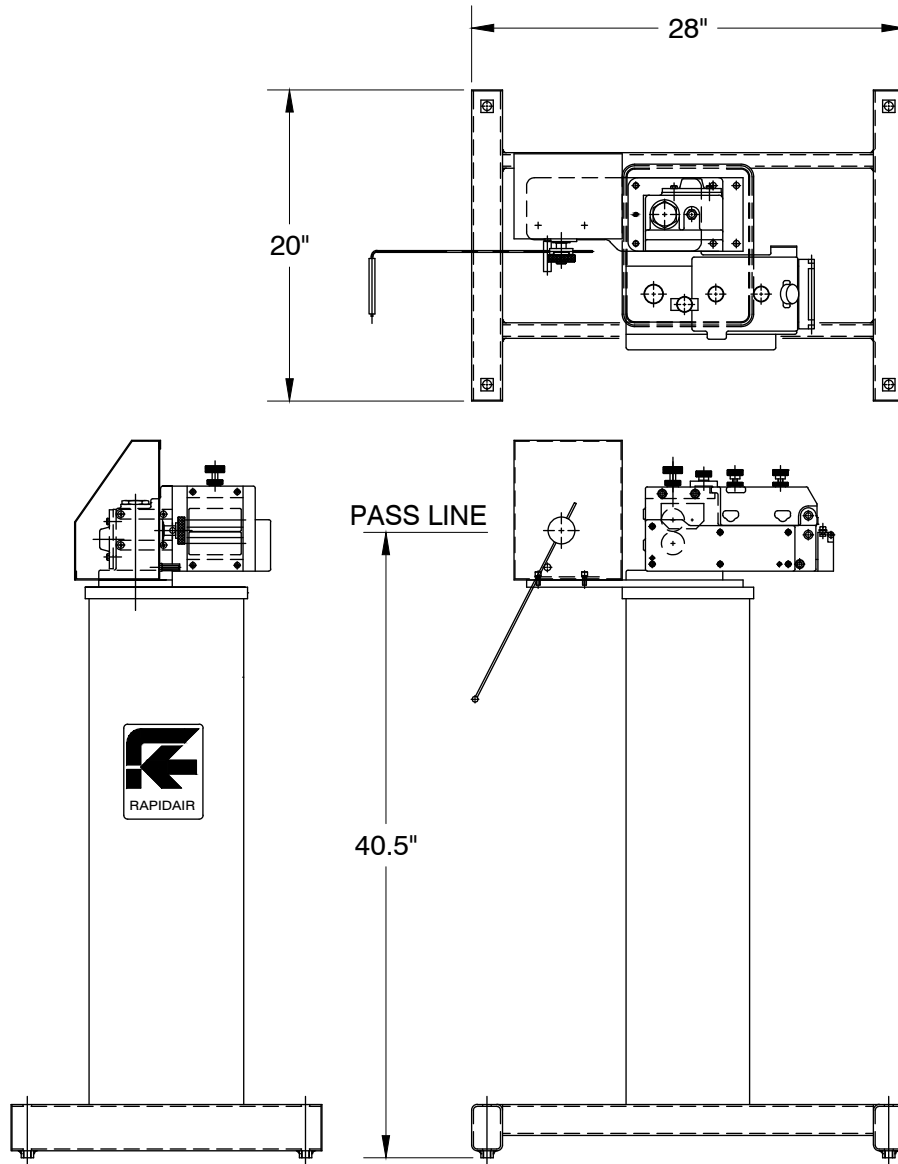

SB4/SB4M CABINET ASSEMBLY

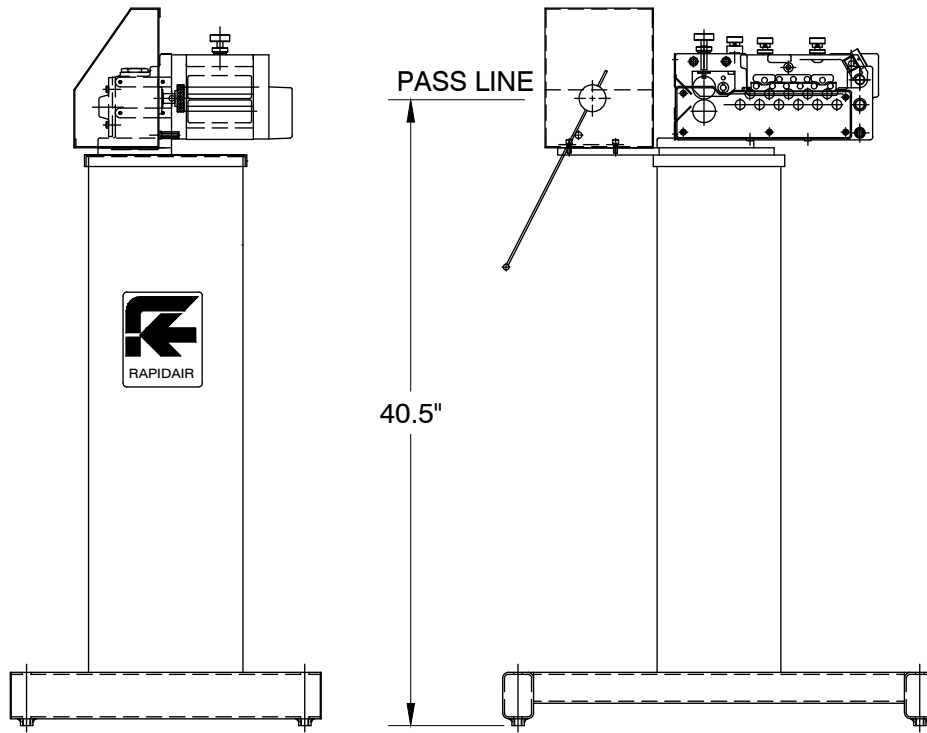
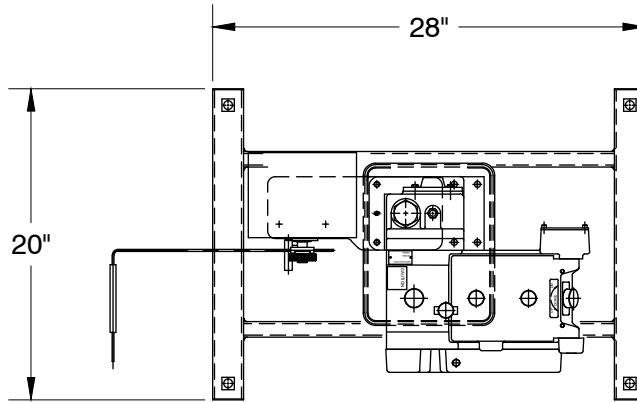

SA3 HEAD ASSEMBLY DRAWING

(sheet 1 of 2)

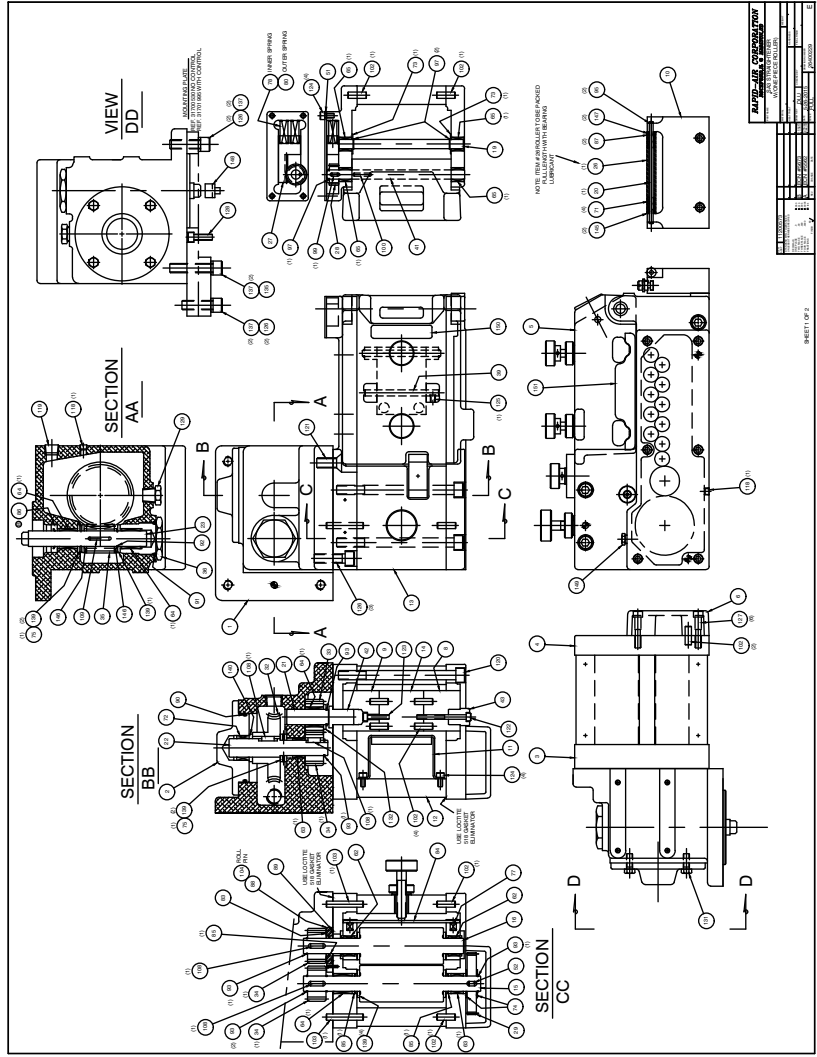

SA3M HEAD ASSEMBLY DRAWING

(sheet 1 of 2)

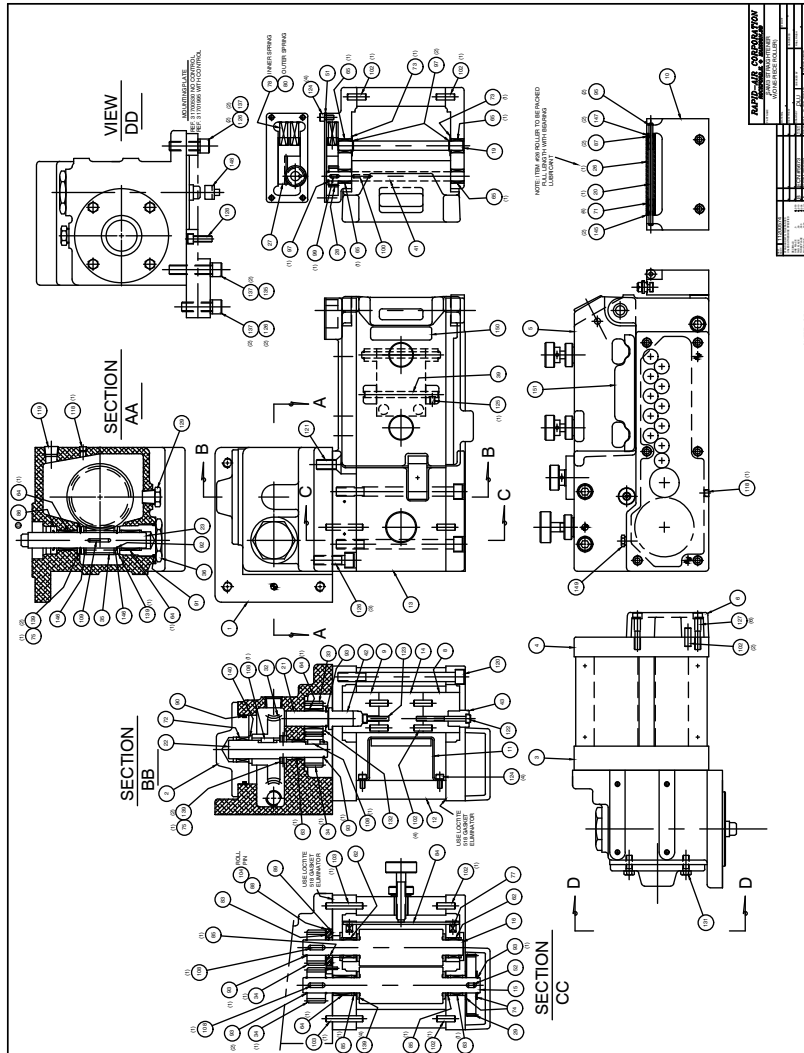

RAVINDRAS CONSULTING	
PROJECT NO.	SA3M HEAD ASSEMBLY
DATE	10/10/2010
SCALE	1:1
DRAWN BY	RAVINDRAS
CHECKED BY	RAVINDRAS
APPROVED BY	RAVINDRAS
DESIGNED BY	RAVINDRAS
PROJECT	SA3M HEAD ASSEMBLY

SHEET 1 OF 2

SB4 HEAD ASSEMBLY DRAWING

(sheet 2 of 2)

