

T-FLEX

CAD/CAM/CAE/PLM

**Design better products
with advanced tools!**

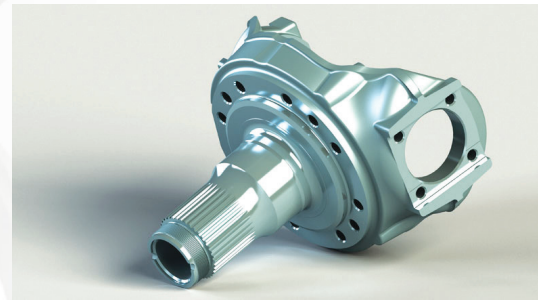
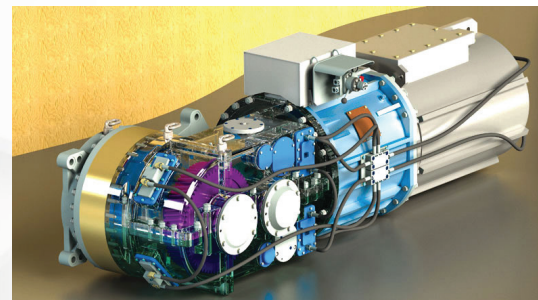
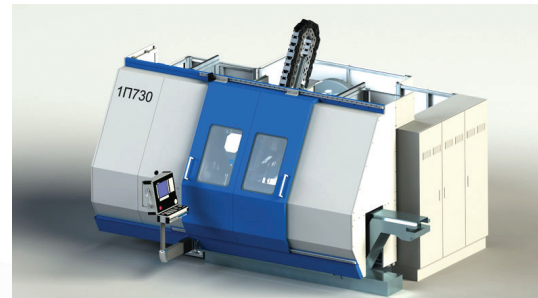
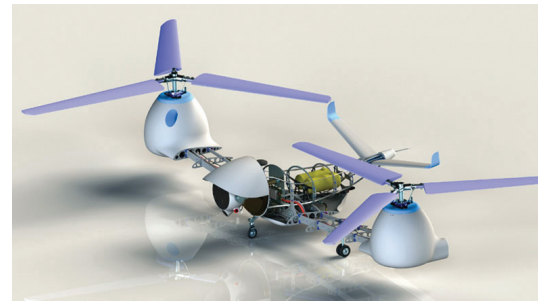

Top Systems



T-FLEX Parametric CAD is a full-function software system providing mechanical design professionals with the tools they need for today's complex design challenges. It unites powerful parametric 3D modeling functionality with the parametric drafting and drawing production toolset.

T-FLEX Parametric CAD - is an industry leading mechanical design system with flexible and intuitive workflow and superior design capabilities. The technical innovations and productivity advantages have made T-FLEX one of the most robust and versatile parametric modeling and drafting solution for product development. Its extensive set of tools makes T-FLEX the best choice for meeting any professional challenge. Engineers worldwide use T-FLEX for the design and manufacture of products for aerospace, automotive, consumer, instrumentation and machine design, mold design, tool and die design, rapid prototyping, medical, defense, electrical, power, furniture industries, industrial construction, woodworking, education and much more.

Modeling Tools

T-FLEX modeling and assembly tools enable your engineering team to easily develop a full range of products, from single parts to assemblies containing thousands of components. T-FLEX harnesses the power of Parasolid® – production-proven modeling kernel developed by Siemens PLM Software.

Highly innovative parametric modeling tools allow designers to quickly create basic shapes and easily add common mechanical features like holes, rounds and chamfers, as well as more complex geometry such as draft angles, lofts, parametric sweeps, three-face blends, and helical features.

Design Workflow

T-FLEX supports a simple unified mode of operations for all types of documents and entities: drawings, assembly drawings, solids, surfaces, parts, parts with multiple solid bodies, assembly models, sheet metal, bill of materials, etc. You use a common set of editing and data management functions on all types of geometry, streamlining workflow.

Parametrics and Adaptivity

T-FLEX cuts down design steps by making changes that propagate instantly throughout your design, incorporating superior design engines for adaptivity and parametrics.

This functionality helps you for example associate parts in a way that allows the change of one part to drive changes in associated parts. Any thing in T-FLEX can be related to anything else. Variables can be assigned at any time for component names, visibility, material, any numeric or text attribute of any entity. They can then be processed with any algebraic or logical expression to control the behavior of the design.

The variables themselves can be changed manually by dragging entities on the screen, or typing values into the variable editor, or by reading ASCII or database files as assigned. Possibilities are endless and the interface is very intuitive. For this reason T-FLEX is a natural choice for family-of-parts manufacturers or any other design situations that use similar geometry but require many different sizes or permutations.

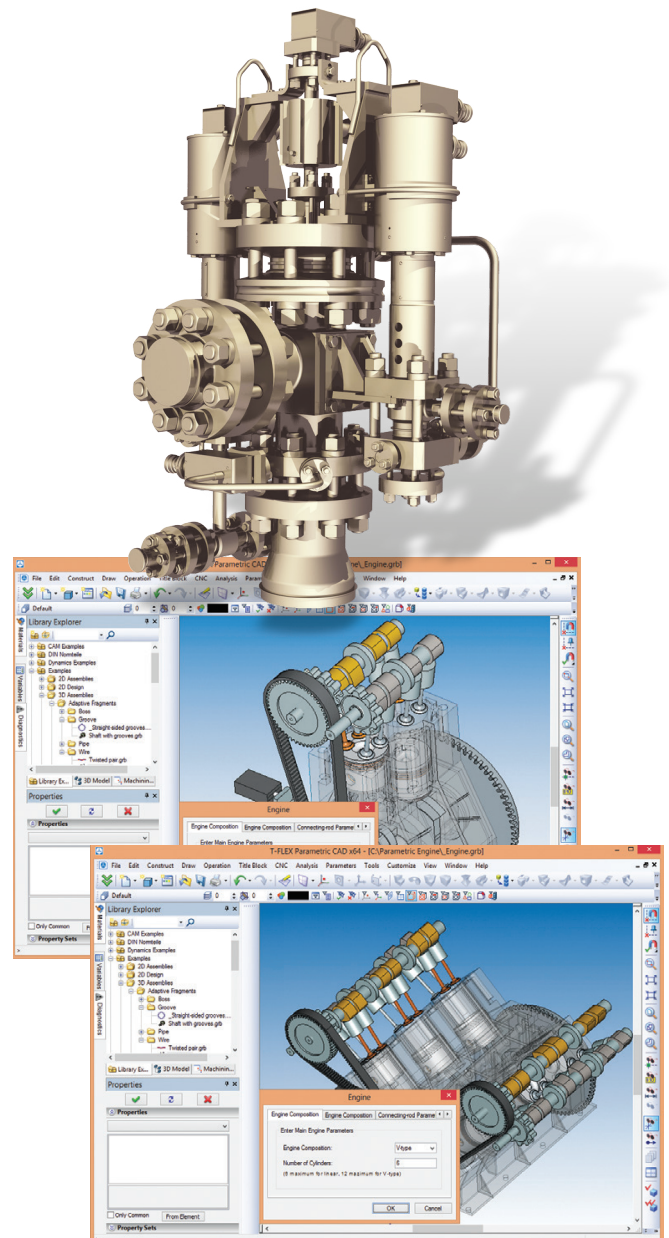

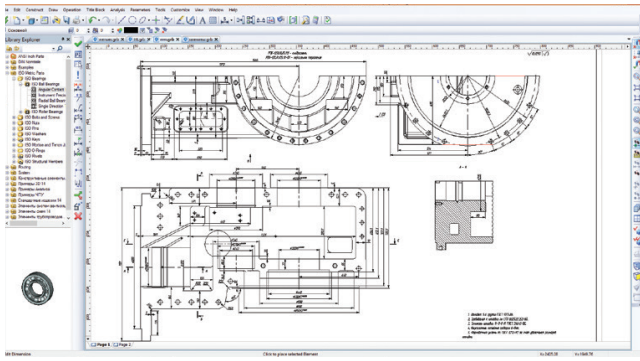

Parametric Drafting

Unlike other products, T-FLEX lets you create parametric 2D drawings from scratch. The 2D CAD roots of T-FLEX are apparent when creating objects. When compared to most other solid modelers, even those focused on product design, T-FLEX has a much more robust palette of 2D tools, especially when it comes to drawing complex geometry. Its parametric engine is the basis of T-FLEX design and unlike engines from other programs is not limited by the number of constrained 2D entities.

T-FLEX drawing or parametric sketch for 3D operations cannot be over or under defined. The drawing immediately updates to any changes regardless of their source.

T-FLEX includes fully parametric drawing documentation, including dimensions, tolerances, text, and drawing notes. You can create parametric 2D assemblies by inserting parametric 2D components with complex parametric relations.

The result can be fully automatic, so that a master parametric drawing does not require any editing as changes are required. Constant re-documentation can be avoided through the use of the powerful documentation parametrics that are inherent in T-FLEX.

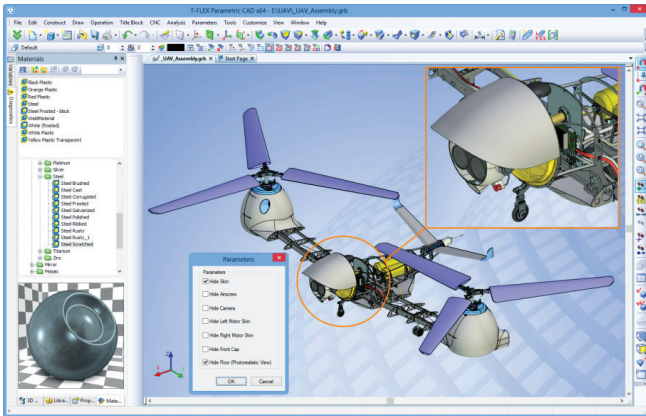

Creating Custom Dialog Boxes

Creating their own dialog boxes of model parameters directly inside T-FLEX users can control parametric model in a very convenient and intuitive way. This unique functionality does not require any programming knowledge or additional software installed.

T-FLEX is a Creative Tool

T-FLEX has one consistent characteristic for its history - its power is best utilized by the most creative designers. The interface is easy to learn and very consistent, but the real power lies in the incredible flexibility of design automation using parametric functionality.

From the beginning the goal was to provide engineers with access to creative design by giving them optimizing control over any aspect of the design process. The program's Total Flexibility approach can truly eliminate redundant tasks and enhance design efficiency.

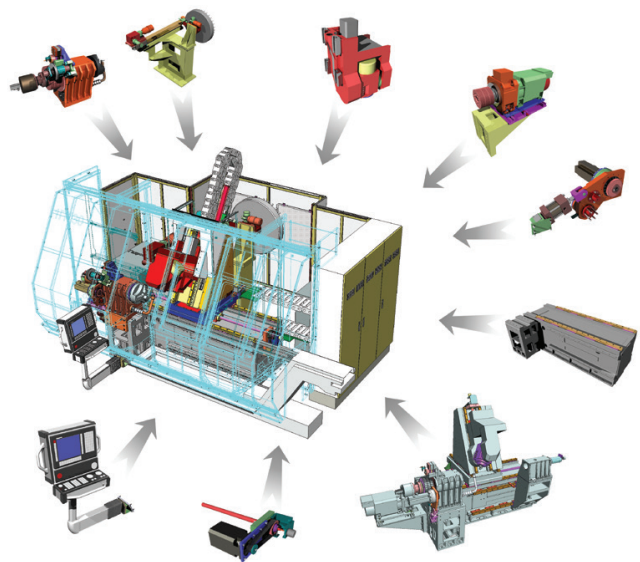

Assembly Modeling

T-FLEX easily tackles assembly 3D models that are fundamental to mechanical design. You can build complex assemblies consisting of many components using bottom-up design, top-down design, or a combination of both methods. Configuration management helps to simplify design reuse by creating multiple product variations within a single document.

T-FLEX can simulate true motion and mechanical interaction between solids that allow you to avoid potential design flaws.

Adaptive Components

T-FLEX supports adaptive technology that allows creating assembly relationships by assigning geometrical links. With this you can capture design intent accurately, and manage and edit assemblies more easily.

Assembly Design Automation

Parametric connectors simplify assembly modeling by automatic parameter assignment for the parts being inserted. Parts location and sizes will adjust automatically on model modification. The structure of an assembly may be alterable. The drawings generated from a 3D assembly will update automatically on model modification with all detailing elements.

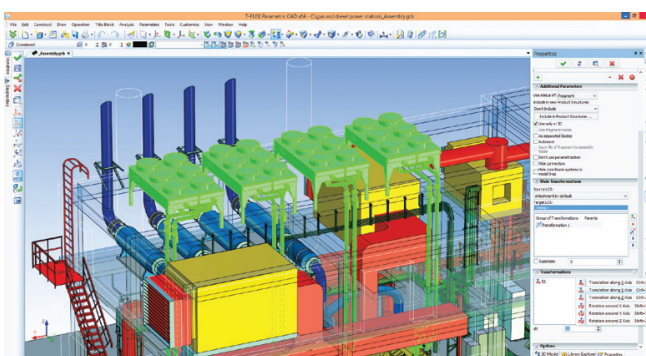

User-defined Features

The innovative technology of parametric user-defined features substantially extends modeling functionality allowing users create their own modeling features. T-FLEX models may capture elements and geometry from other models as input parameters of operations inside their own model history tree. In that way any T-FLEX model can be defined as a special feature that will function equally with other modeling commands. This mechanism can dramatically reduce the modeling time providing users with the possibility of creating their own features and libraries of features for specific modeling tasks.

Deformation Commands

The set of deformation commands provide a simple way to change shapes of complex surface or solid models. Deformation may be applied either in a local area or globally. Various options may be specified by direct rules and parameters or via the special handlers.

Surfacing

T-FLEX synergistically combines solid and surface modeling enabling designers to extrude, sweep, revolve, and loft surfaces as can be done with solid models. It also enables to do things that can't be done with parametric solids alone. For example, a designer can draw lines or curves in space and fit surfaces between them, or add surfaces that blend between non-intersecting surfaces. Integrated surface and solid modeling provides flexibility in making design changes through the use of parametrics, constraints, and associative operations.

Direct Editing

T-FLEX supports direct editing of 3D models, retaining history of the edits so that they can be regenerated. This is very helpful for the imported models when there is no access to the original history tree.

For example it is possible to modify parameters of the faces whose underlying surfaces are analytical (cylinder, cone, sphere and torus), as well as the parameters of faces created as blends. Other editing features include imprinting, face replacement, face extension, face removing, body separation, etc.

Detailing Features

Professional detailing functions support quick creation and complete manipulation of all common annotations used on mechanical drawings.

T-FLEX contains an unmatched set of capabilities for the 2D documentation process, with excellent drawing layout, detailing, annotation and dimensioning controls that automatically comply with the mechanical drafting standard you select.

T-FLEX automatically creates and updates drawings from 3D models, quickly creating standard and auxiliary views, including section, detail, broken and isometric views. T-FLEX provides flexibility and control of section views with improved control of the depth of a slice and selection tools that allow you to predefine components on a per view basis when creating section views. As changes are made to parts or assemblies, associated drawings update automatically.

Associative Bill of Materials (BOM)

T-FLEX can generate and update an accurate BOM in a fraction of the time required by traditional 2D methods. Part and subassembly quantities are always kept up to date, and are instantly organized and populated into a

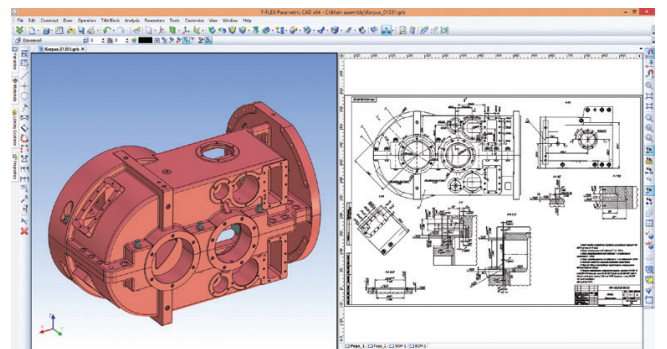

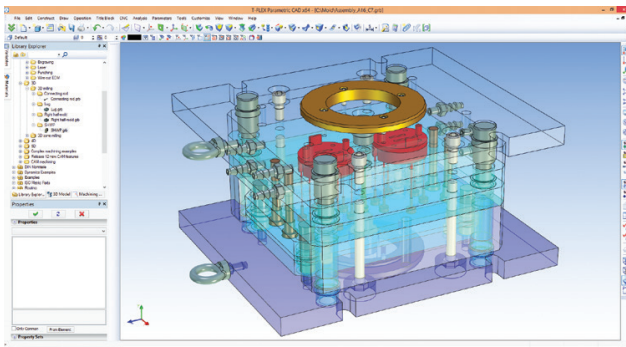

drawing BOM.

Changes to the assembly (removing a part, for example) are associative, so the BOM table is updated automatically. BOM templates and table properties (column headings, sorting, title blocks, etc.) are fully customizable.

Mold Design

T-FLEX provides a sequence of integrated tools that control the mold creation process. You can apply body taper; generate parting lines and surfaces; resize the model's geometry to account for the shrink factor when plastic cools; perform tooling split to separate core and cavity. With the model finished, you can examine it for potential problems that might prevent the core and cavity from separating.

Integrated Sheet Metal Design

T-FLEX provides a set of commands tailored for the efficient construction of sheet metal parts from design of sheet metal components to flat pattern development and the creation of engineering drawings.

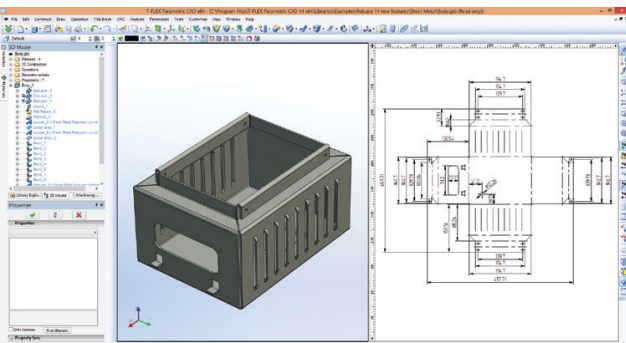

Express FEA

Built-in Express Analysis offers an easy-to-use first pass stress analysis tool that enables design engineers to execute design verification directly in T-FLEX.

It helps to determine how designs will perform under real-world conditions, and identify potential design flaws before expensive physical prototypes are built. Express Analysis uses the same design analysis technology that professional FEA add-on module uses to perform stress analysis.

More advanced analysis capabilities are available within the T-FLEX Analysis line of products.

Interactive Motion Simulation

T-FLEX provides a motion simulation solution for analyzing the complex behavior of mechanical assemblies. T-FLEX Dynamics allows you test virtual prototypes and optimize designs for performance, safety, and comfort, without having to build and test numerous physical prototypes. Results are viewable as graph, data plots, reports, or colorful animations that you easily can share with others.

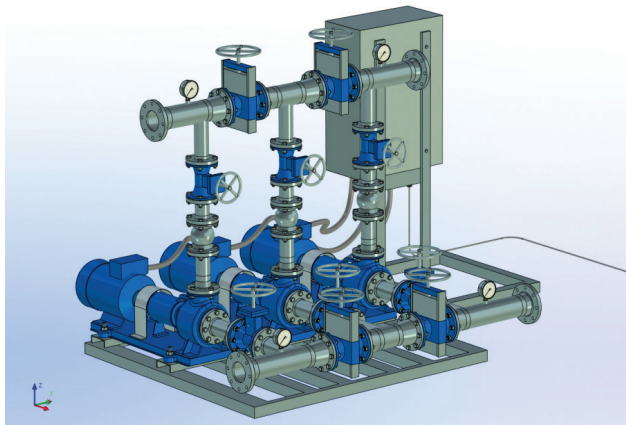

Weldment Design and Documentation

T-FLEX lets you work in a weld-specific environment with functionality tailored to the unique design requirements of designing and documenting weldments. Model weldment annotations are associated with the model and automatically get updated when the model is changed.

Piping and Cabling Design

T-FLEX CAD includes design tools that automate routed systems design. It speeds up the process of routing tube, pipe, venting, electrical cable, and harnesses across various manufacturing industries and types of piping and cabling systems.

Open API

T-FLEX Open API is based on .NET technology offering customers and third-party developers extensive possibilities for developing add-on applications in various areas. T-FLEX's set of entities can be extended with the custom objects. T-FLEX Open API supports full object oriented programming concepts and multiple programming languages with identical functional access to all T-FLEX functionality.

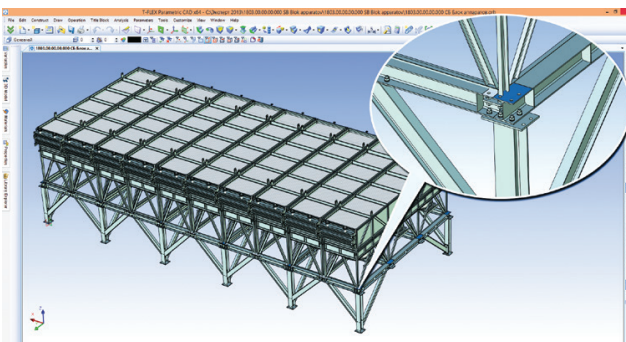

It also helps users to customize T-FLEX for their specific environment and automate specialized workflows.

Parametric Engine for Internet

Using T-FLEX and T-FLEX Open API, third parties, OEMs, developers, and system integrators can deliver parametric CAD functionality across a wide range of Internet-based products. T-FLEX utilized as an Internet engine, provides engineers, manufacturers and distributors with opportunity to display their products, use third-party designs and perform marketing activities.

Multilingual Support

T-FLEX is a Unicode application and hence supports all of the languages around the world. Unicode support in T-FLEX means that users can utilize multilingual text that will be displayed correctly in T-FLEX documents. There will be no problems with any language files names under any language version of Windows operating system. Users can name objects and parameters in whatever language they like.

Interface Flexibility

T-FLEX's multiple interface options help maximize productivity by allowing users to choose an interface that matches their experience and preferences. The user interface is specifically designed to remove command clutter and operational complexity. The Windows-style pull-down menu interface is easy to navigate. Compact text-based command bar, icon toolbars and shortcut key assignments are also available. Enhanced capabilities, such as intelligent positioning tools and pop-up menus driven by hot key activation, greatly simplify workflow. T-FLEX provides direct model interaction, using 3rd mouse button, dynamic geometry preview, and support for SpaceMouse® to seamlessly blend frequent and advanced capabilities.

Advanced Graphics Subsystem

High performance 3D graphics mechanisms ensure convenient operations even with very large assemblies. There is also possibility to generate high quality photorealistic images based on lighting and material properties such as transparency, refractive index, surface properties, etc.

Translators

The rich suite of T-FLEX translators enables you to satisfy differing import and export requirements, effortlessly. T-FLEX is interoperable with the most widely used 3D-modeling and 2D-drawing systems via the following formats: Parasolid, IGES, STEP, Rhino, STL, DWG, DXF, SolidWorks, Solid Edge, Inventor, etc. Additionally, T-FLEX provides options for exporting graphical images to presentations, web pages, and other documentation.

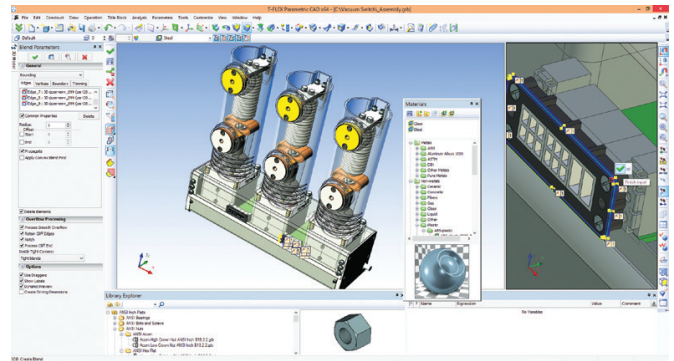
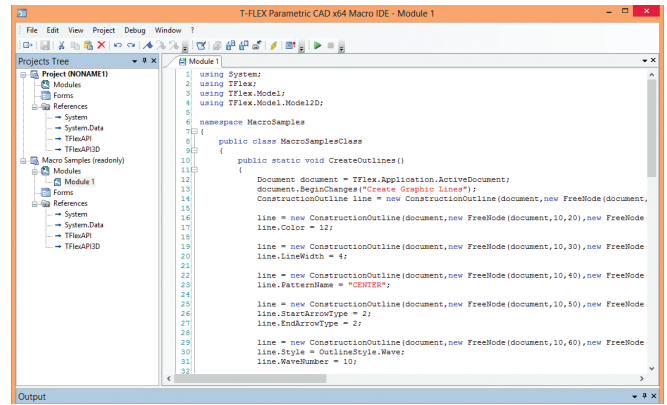

T-FLEX CAM is a fully integrated manufacturing add-on to T-FLEX CAD for generating NC programs as well as toolpath verification and machine simulation with material removal. It provides comprehensive machining tools for a broad spectrum of manufacturing sectors.

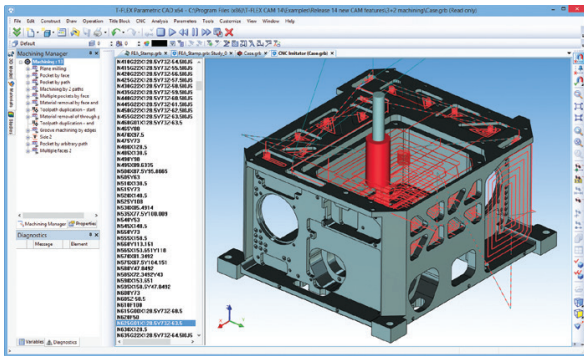

System for a Full Range of Machine Tool Applications

T-FLEX CAM offers solutions for NC programmers involved in milling, drilling, turning, punching, wire EDM, laser and plasma cutting. In combination with T-FLEX CAD, T-FLEX CAM provides fully associative, integrated tools for product design and NC. T-FLEX CAM uses the same T-FLEX CAD geometry to generate toolpaths to ensure the part you machine is the same part you have modeled. Toolpath and machine simulation in T-FLEX CAM help manufacturing engineers quickly improve NC program quality and machine efficiency. With T-FLEX CAD data import and design tools that are fully associative with NC, companies can reduce design-to-manufacturing turnaround times and quickly adjust to design changes. T-FLEX CAM also offers postprocessing, tool editors and industry-specific machining solutions that automate interrelated tasks in the manufacturing process. T-FLEX CAM is available in a variety of configurations, so you can purchase exactly what you need now and add to your system as your business grows.

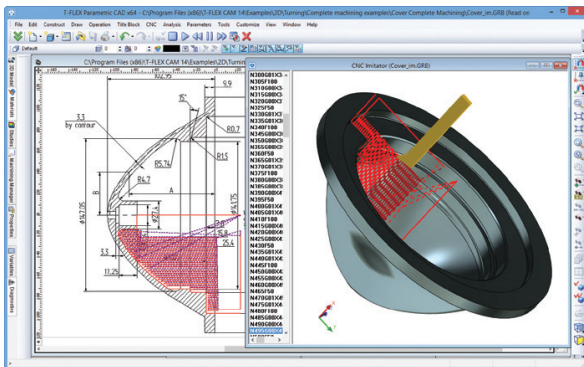

Parametric CAD/CAM integration

T-FLEX CAM allows manufacturing engineers to take a more central role in providing design feedback, while allowing associative NC toolpath creation to proceed concurrently with design. Because of T-FLEX CAM's ability to maintain complete associativity and synchronization with the 3D product model, the manufacturing information can be updated directly from the design data. Process definition and NC programming can begin sooner and design changes are much easier to accommodate. The result is increased productivity and improved quality. Fully associative geometry and toolpaths let you modify the geometry or machining parameters and immediately get an accurate, updated toolpath. With the single-window integration of T-FLEX CAM in T-FLEX CAD, all machining operations are defined, calculated and verified without leaving the T-FLEX CAD environment. All 2D and 3D geometries used for machining are fully associative to the parametric T-FLEX CAD design model. When the geometry used to define a machining operation is changed in a T-FLEX CAD design, T-FLEX CAM enables the user to automatically synchronize all machining operations with the updated geometry. Associativity is provided between the T-FLEX CAD model and T-FLEX CAM machining in all machining operations.

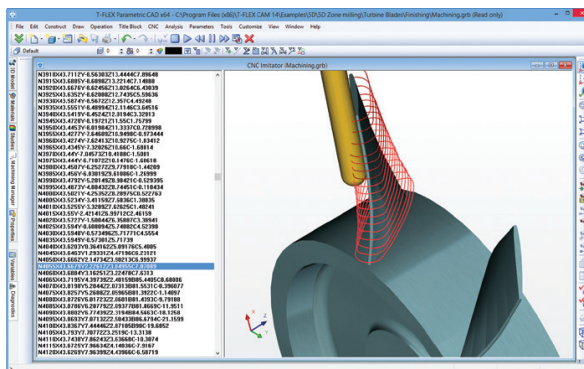

Wire EDM

T-FLEX CAM provides a universal EDM mechanism to machine any contoured mold, die, core, cavity, shape or profile. This versatile machining mechanism supports straight or tapered rough and skim cuts while optimizing wire cutting paths. Fully associative geometry and wire paths let you modify geometry or machining parameters and immediately get an accurate, updated wire path. T-FLEX CAM supports 2D, 2.5D, 4D cutting of any complexity with circular interpolation of curves including two-contour machining. The same features can be applied for waterjet, laser or plasma cutting.

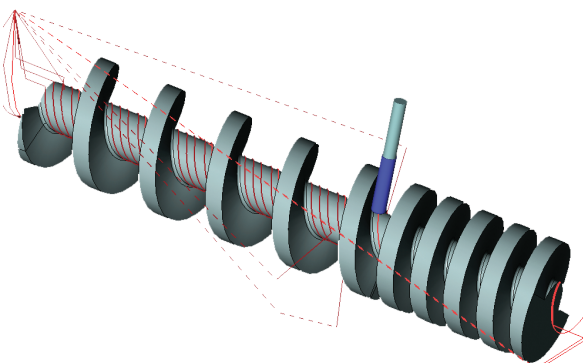

Production Turning

Whether you are looking for a CAM system to automate your traditional turning "from roughing and grooving to threading and finishing" for faster, more accurate results, or to maximize your multi-axis machine tool investment, T-FLEX CAM is the right choice. Its comprehensive suite of universal machining cycles includes support for typical features like grooves and pockets as well as machining strategies for rough, semi-finish and finish turning, together with support for facing, boring, drilling, threading and cut off turning. T-FLEX CAM supports several industry standard canned cycles tuned for various machining centers. User-defined machining cycles can be created in special Editor of Machining Cycles.

Drilling and Hole Making

Drilling, deep-hole drilling, peck drilling, reaming, boring, tapping, and many other point-to-point pre-programmed and canned machining cycles are available as well as customizable drilling cycles. T-FLEX CAM's custom machining cycles give you complete control over cutting tool movements to represent your current machining environment.

2.5D Milling/Engraving

T-FLEX CAM's 2.5D milling module enables users to quickly produce toolpaths from T-FLEX CAD drawings data. It includes roughing, finishing, pocketing, pencil tracing, engraving and various specific features like helical groove with helical interpolation support. The pocketing cycle provides full tool control and extensive automation for roughing and finishing pockets of any complexity. The broad variety of pocket machining, finishing patterns, and cutting strategies provided by T-FLEX CAM yields virtually unlimited options for your milling needs. T-FLEX CAM easily engraves any TrueType® font and gives you the effect of classic hand-carved art using your CNC machine.

Punching

T-FLEX CAM's punching module includes an entire set of commands for interactive insertion and positioning of single tool hits or cycles with full support of micro-joint placement and editing, including support for special tools. When a new tool is created with T-FLEX CAM punching module, the definition includes all of the information necessary to provide the greatest control over tool use. The tool-path can be reviewed at any time with tool-path simulation. Tool hits can be stepped through one at a time, by tool sequence, or full simulation. T-FLEX CAM provides automatic tool-path optimization to minimize CNC machine run-time.

3D Milling

T-FLEX CAM's highly productive 3D milling can be used for both surface and solid models.

You can create machining strategies for roughing and finishing multi-surface models using several techniques. You can specify boundaries to limit the bodies or their cross sections, apply special algorithms for edge/flange finishing, and calculate toolpath for helical circle milling.

The program offers support for constant Z-levels and equidistant approaches producing particularly smooth surface finishes. Pencil cutting allows to machine sharp or filleted details even if they have not been filleted. T-FLEX CAM adds an extra level of flexibility to your machining operations working on both smooth mathematically correct geometry and triangulated models.

Advanced 5D Milling

T-FLEX CAM provides an industry competitive 5-axis milling capability with comprehensive options of tool positioning relative to a work-piece. Optimal toolpath for complex surfaces is derived based on iso-parametric curves or

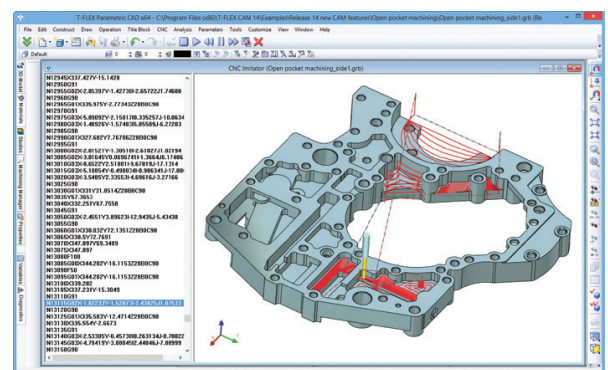
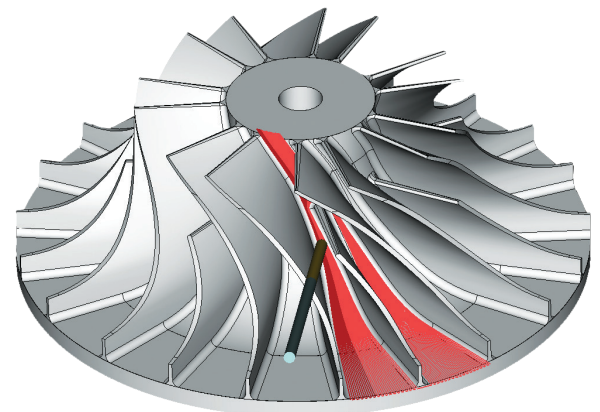
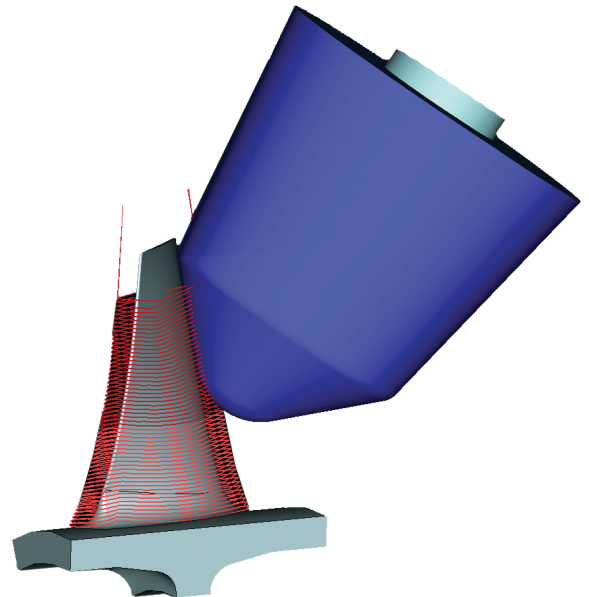
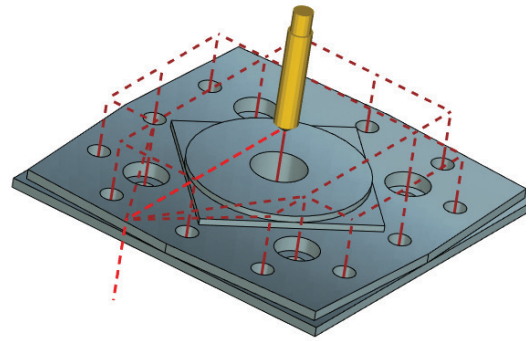

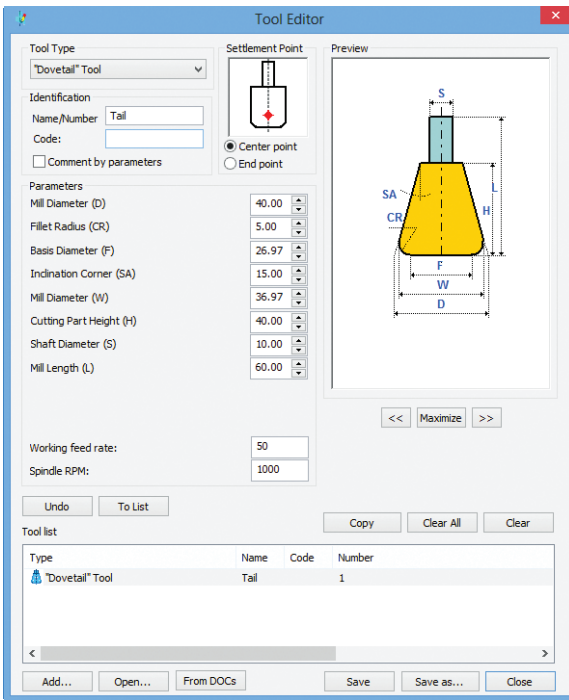
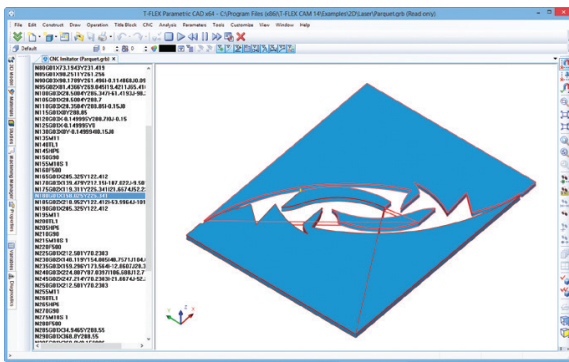

orienting paths. By utilizing this technique, the resulting toolpath is exact and compact as opposed to contoured piecewise linear data that is generally used. Tool axis interpolation is another strategy in T-FLEX CAM's 5-axis machining. It provides capability of generating a gouge-free toolpath. In this case, the tool axis is controlled with multiple vectors, lead angles, or orienting paths.

Toolpath generation for complex surfaces with double curvature is also supported on the base of "composite surface" single parametric area for tool orienting.

T-FLEX CAM offers both positional and continuous 5-axis machining. Positional machining supports parametric definition of the head orientation in the indexed machining areas. Continuous machining allows the user to create continuous toolpaths across complex surface, solid or triangulated models. The toolpaths are fully gouge checked and support a wide range of machining strategies and all tool types. By using the swarf cutting option, optimum machining of complex parts, e.g. impellers, is a simplified process. T-FLEX CAM also allows to set variable machining allowances and feed rates in the predefined parametric regions.

5D Drilling

5-axis drilling lets you cut holes approaching the part from any angle. It quickly rotates the tool to line up with the hole, reducing the need to reset the part, producing huge time savings and increasing accuracy and surface finish. T-FLEX CAM supports various machining cycles of 5D drilling, facing, deep-hole drilling, boring and thread tapping.

Cam-shaped Milling

The special milling of cam-shaped forms is aimed at machining surfaces of revolution or their sectors.

The concentric cutting passes for this type of machining are oriented orthogonal to the axis of cam rotation. The forming tool movement is defined by cam geometry and corresponds to the pusher motion law of cam mechanism.

NC Simulation and Verification

T-FLEX CAM provides realistic graphical verification, ensuring that programs are correct before being executed. All types of machining can be verified. The program shows your part being cut from a block of material, optionally imported as a T-FLEX CAD model.

You can detect collisions and errors before the program is loaded on the machine and also optimize your NC program for more efficient machining. The simulation result saved for comparison with the real model designed in T-FLEX CAD. The program supports full implementation of forward kinematics and considers geometric offsets of jig and tool.

Flexible Tooling Options

T-FLEX CAM simplifies the tooling definition process and gives you full tooling support, from standard to complex custom form tools for all types of machining. The software features a parametric-based graphical tool editor for interactive definition of tool construction on the base of geometrical and machining parameters that position the cutting point of a tool.

Postprocessing Capabilities

T-FLEX CAM provides a substantial built-in library of postprocessors for all types of machines. The software also includes a postprocessor generator to create and modify table postprocessors to meet the requirements of your equipment. User can specify individual formats and structure of NC program. For complex types of machining you can develop a special postprocessor using direct programming on the base of existing templates provided in source codes.

T-FLEX Analysis

T-FLEX Analysis offers a wide spectrum of specialized analysis tools to help engineers virtually test and analyze complicated parts and assemblies. It employs the finite element method for performing static, frequency, buckling, thermal, optimization, fatigue and other analysis. T-FLEX Analysis shows how a model will perform under real-world conditions before it is built.

Associative Model

The CAE model is fully associative to the design model, since it uses native T-FLEX CAD geometry. T-FLEX Analysis ensures that the very latest design information is available for simulation without the need for any time-consuming geometry translation or data re-creation. Design changes made in a model are automatically updated for analysis calculations. Meshing is automatic and completely adaptive to even the most complex model geometry.

User Interface

Complete integration with T-FLEX CAD means that T-FLEX Analysis users can perform design analysis, simulation and optimization directly from their T-FLEX CAD user interface. T-FLEX Analysis utilizes the T-FLEX CAD Model Tree, Properties dialog boxes, command and menu structure, and many of the same mouse and keyboard commands, so anyone who can design a part in T-FLEX CAD can analyze it without having to learn a new interface.

Area of Application

Quick and inexpensive analysis often reveals non intuitive solutions and benefits engineers by providing them with a better understanding of product characteristics. Whether used in the mechanical, electromechanical, aerospace, transportation, power, medical or construction industries, T-FLEX Analysis can help to shorten development time, reduce testing costs, improve product quality, increase profitability, and cut time to market.

Structural Static Analysis

Structural analysis capabilities enable engineers to perform static stress analyses of parts and assemblies under various loading conditions. Static studies calculate displacements, reaction forces, strains, stresses, and factor of safety distribution. Static analysis can help you avoid failure due to high stresses. Various structural loads and restraints can be specified including force, pressure, gravity, rotational load, bearing force, torque, prescribed displacement, temperature, etc.

Frequency Analysis

Frequency Analysis determines a part's natural frequencies and the associated mode shapes. It can determine if a part resonates at the frequency of an attached, power-driven device, such as a motor. While resonance in structures must typically be avoided or damped, engineers may choose to exploit resonance in other applications. The typical applications include acoustical speaker design, aerospace structure design, bridge and overpass architecture, construction equipment design, musical instrument study, robotic system analysis, rotating machinery and turbine design, vibrating conveyor optimization and others.

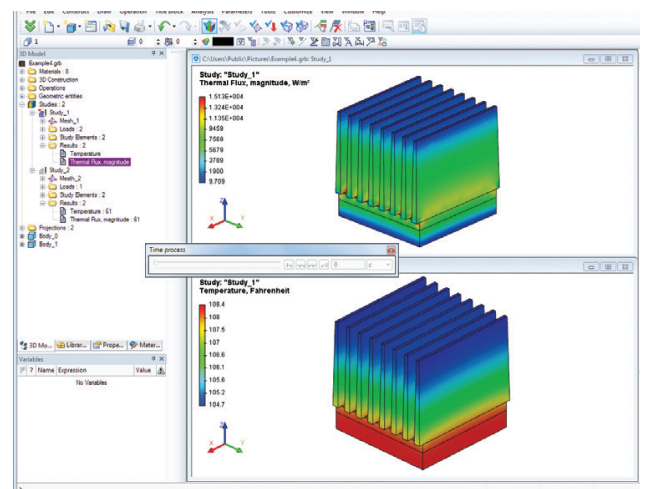
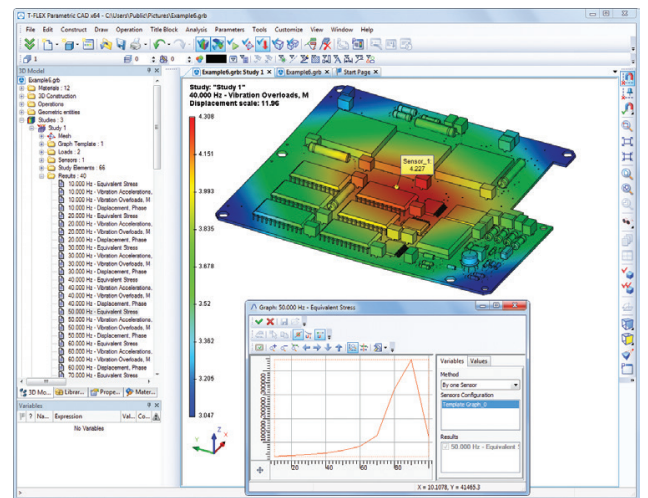
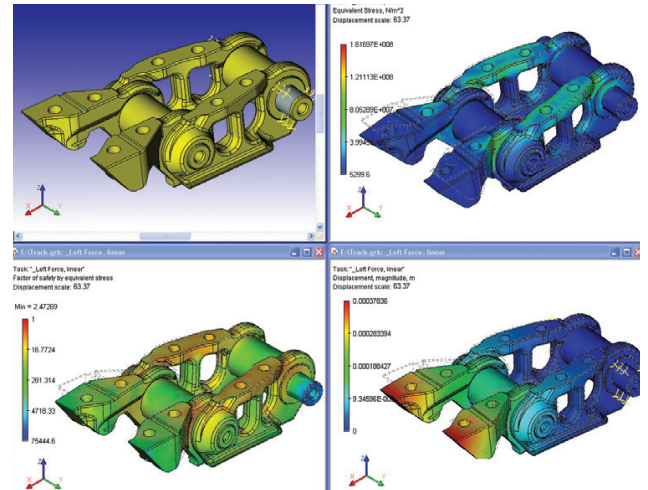

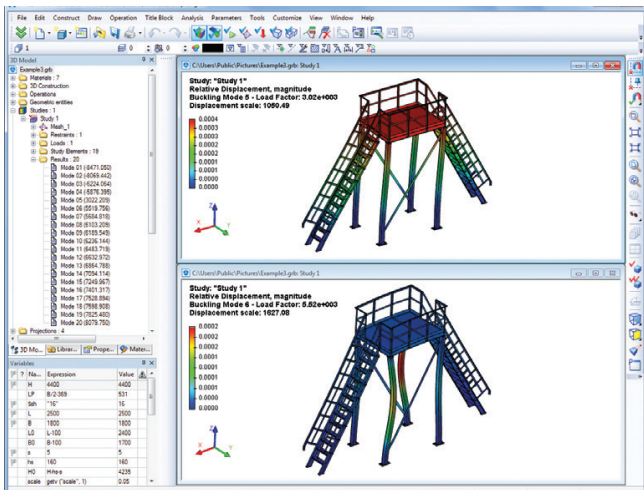

Buckling Analysis

Critical buckling load analysis examines the geometric stability of models under primarily axial load. It helps avoid failure due to buckling which refers to sudden large displacements and can be catastrophic if it occurs in the normal use of most products. Buckling analysis provides the lowest buckling load which is of interest and is usually used in such applications as automotive frame design, column design, infrastructure design, safety factor determination, transmission tower design, vehicle skin design and others.

Thermal Analysis

Capabilities for simulating thermal effects include steady-state and transient heat transfer analysis. Thermal studies calculate temperatures, temperature gradients, and heat flow based on heat generation, conduction, convection, and radiation conditions. Thermal analysis can help you avoid undesirable thermal conditions like overheating and melting.

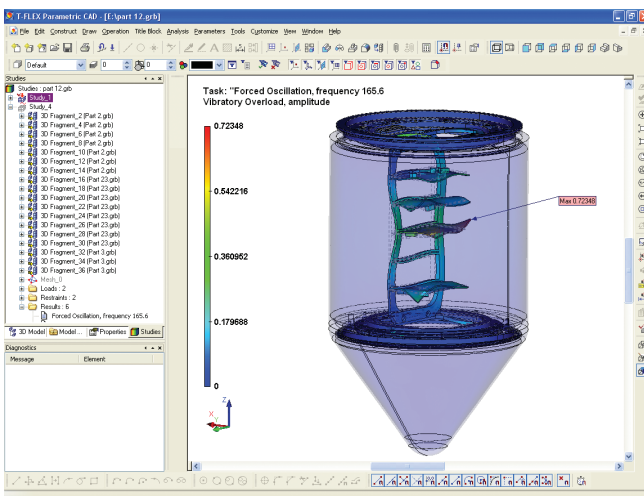

Optimization

Designing and producing innovative products that meet performance criteria is a goal of every manufacturer. Using optimization techniques, engineers can improve a proposed design, resulting in the best possible product for minimum cost. Because your designs may have hundreds of variable parameters with complex interrelationships, finding an optimal design through manual iterations is hit-or-miss at best. T-FLEX Analysis relieves the burden of improving product designs by automating the iterative process of comparing performance against specifications.

Frequency Response Analysis

Frequency response analysis determines the steady-state operation of a machine, vehicle or process equipment design subjected to continuous harmonic loading. As compared to linear transient stress analyses, frequency response analysis provides an easy, quick method in which the only inputs are a constant frequency and amplitude. For example, this analysis type could be used to determine the vibration effects of a washing machine with an unbalanced load or a bent wheel on a vehicle.

Fatigue Analysis

Repeated loading and unloading weakens objects over time even when the induced stresses are considerably less than the allowable stress limits. Fatigue analysis is vital for products such as steel rails, beams and girders, which can experience mechanical failure under repeated or otherwise varying loads that never reach a level sufficient to cause failure in a single application. T-FLEX Analysis simulates fatigue-based failure and lets users design for durability by subjecting a product to cyclic applications of stress in order to determine its endurance limit and thereby ensure safety.

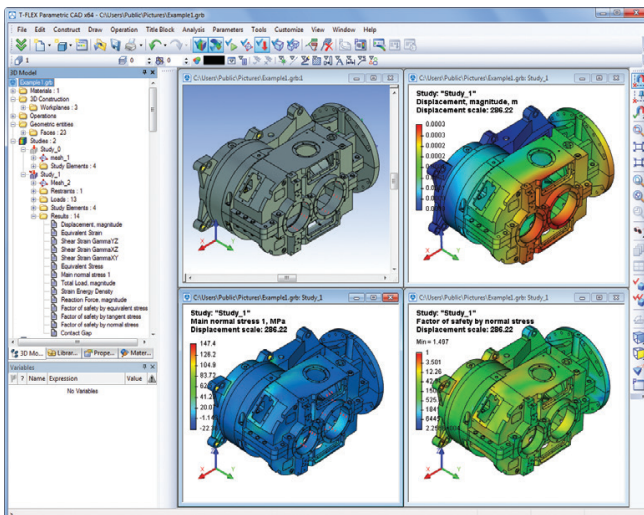

Analysis Results (Post Processing)

T-FLEX Analysis provides a comprehensive range of post processing operations with animation, various plots, lists, and graphs depending on the study and result types. The special reporting command helps you document your studies quickly and systematically by generating Internet-ready reports. The reports are structured to describe all aspects of the study.

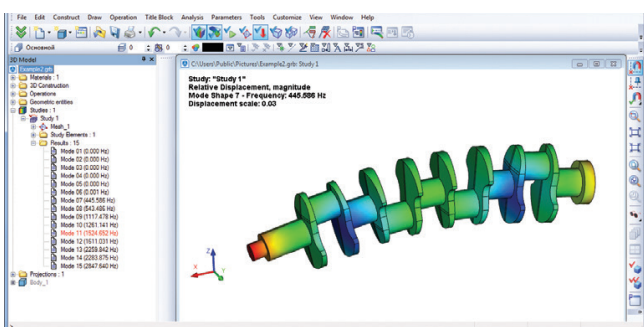

T-FLEX Dynamics

T-FLEX Dynamics is a general-purpose motion simulation add-on application for studying the physics-based motion behavior of a CAD design without leaving the T-FLEX CAD environment. T-FLEX Dynamics is the virtual prototyping software for engineers and designers interested in understanding the performance of their assemblies. It lets you make sure your designs will work before you build them.

Behavior of Mechanical Assemblies

When designing a mechanical system such as an automotive suspension or an aircraft landing gear, you need to understand how various components (pneumatics, hydraulics, electronics, and so on) interact as well as what forces those components generate during operation. T-FLEX Dynamics is a motion simulation solution for analyzing the complex behavior of mechanical assemblies. T-FLEX Dynamics allows you design and simulate moving assemblies so that you can find and correct design mistakes, test virtual prototypes and optimize designs for performance, safety, and comfort, without having to build and test numerous physical prototypes. Fewer physical prototypes, not only cuts costs, but also reduces time to market, giving you a better quality product, that is built right the first time.

Physics-based Models Associated to Engineering Conditions

T-FLEX Dynamics offers several types of joint and force options to represent real-life operating conditions. As you build your T-FLEX CAD assembly model, T-FLEX Dynamics can automatically create the parts, joints and contacts of your mechanism generating them from assembly constraints and from model geometry. There are no limitations on the contact types since the program provides accurate analysis of the contacting bodies based on the Parasolid geometry, eliminating the need to define manually contact constraints. Each contact pair can be described with specific impact and friction parameters. T-FLEX Dynamics allows you to determine how your design will react to dynamic forces, such as gravity and friction. You can use forces to model spring and damping elements, actuation and control forces, and many other part interactions. Forces can be applied even interactively by dragging the parts during computation.

Industry Application

By combining physics-based motion with assembly information from T-FLEX CAD, T-FLEX Dynamics can be used in a broad span of industry application like analyzing control systems, such as hydraulics, electronics, pneumatics; understanding robotics performance during operation; optimizing or minimizing the force imbalances in rotating systems; understanding gear drives; simulating realistic motion and loads of suspension systems; evaluating the dynamic behavior of space assemblies, such as launchers and satellites; optimizing consumer and business electronics; predicting component and system loads for fatigue, noise or vibration; etc.

Reviewing Results

After simulating an assembly, you have a variety of results visualization tools in the form of XY graphs or numerical data of displacements, velocities, accelerations, force vectors at joint locations, displaying a trace

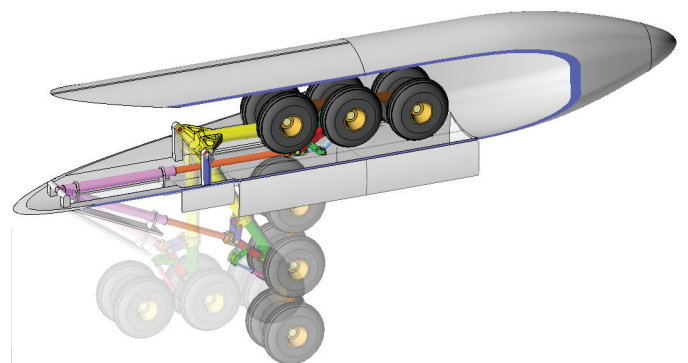
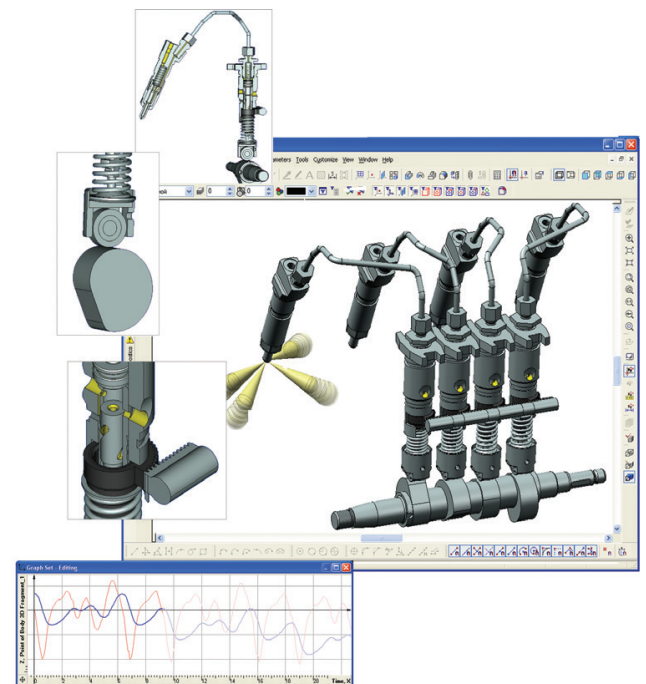

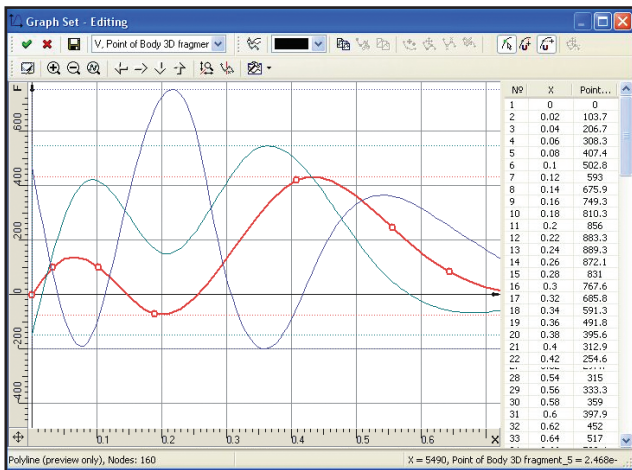

on any point of the body during the entire simulation, etc. Special “pair of bodies” sensor measures reaction forces and friction in the contact point. You can animate your mechanism during or immediately following a simulation. Using animations and XY graphs inside T-FLEX software you can size motors/actuators, determine power consumption, layout linkages, develop cams, size springs/dampers, and determine how contacting parts behave. Synchronized graphing and animation directly associate force and acceleration values with mechanism positions. T-FLEX Dynamics also calculates loads that can be used to define load cases for structural analyses.

User Interface

T-FLEX Dynamics’ user interface is a seamless extension of T-FLEX CAD. Your investment in T-FLEX CAD software and training will be preserved and enhanced, and you will have a powerful new tool to evaluate the form and fit and function of your product designs. Unlike other products, which are merely separate applications that exchange geometric data with CAD, T-FLEX Dynamics operates directly on the same geometry that describes your design.

Fast and Accurate Handling of Large Models

Today, the use of large prototype models in industrial development processes depends on the efficiency and speed of the way such large models are handled. With its effective solving techniques and advanced data manipulation, T-FLEX Dynamics is perfectly capable of processing large-size models. The algorithms implemented in the solver are optimized to provide the right accuracy and to deliver results fast.

Express Dynamics in T-FLEX CAD

Express Dynamics, a limited version of T-FLEX Dynamics, allows the functional performance of designs containing components such as linkages, motors, actuators, cams, gears, springs and others to be evaluated by creating animations of the design as it works and by checking for interference between all the components in your design as it operates. Best of all, you already have it; Express Dynamics comes with every copy of T-FLEX CAD.

T-FLEX Dynamics Benefits

- Create more innovative products by using the time savings gained from virtual testing to evaluate more design ideas.
- Identify and optimize the parameters that have most impact on the real-life performance of a design.
- Dimension motors and actuators by computing the forces and torques needed to generate desired mechanism motion.
- Work in a secure virtual environment, without the fear of losing critical data due to instrument failure or of falling behind schedule due to poor weather conditions, common elements that accompany real-world testing.
- Reduce risk by getting better design information at every stage of the development process.
- Analyze design changes much faster and at a lower cost than physical prototype testing requires.
- Improve product quality by exploring numerous design variations in order to optimize full-system performance.
- Vary the kinds of analyses being performed without having to modify physical instrumentation, test fixtures, and test procedures.

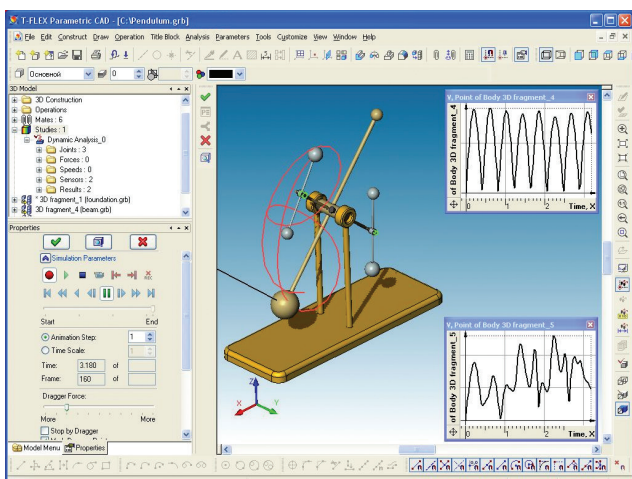
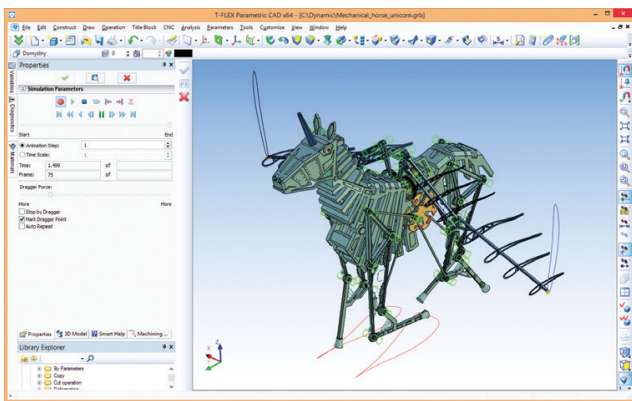
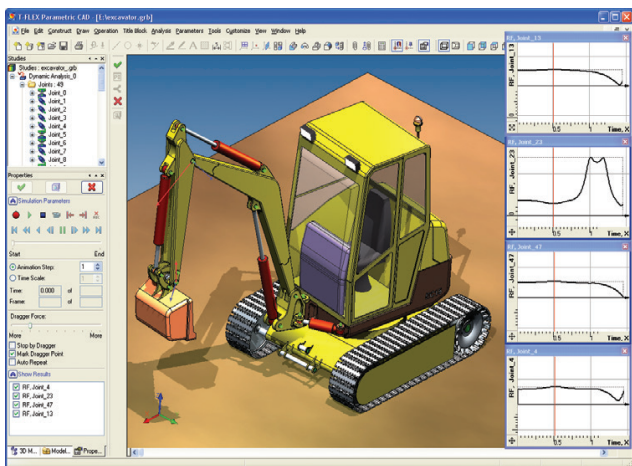

T-FLEX DOCs

T-FLEX DOCs software is professional Product Lifecycle Management (PLM) system, helping companies manage increasingly complex products, streamline operations, and increase productivity. With T-FLEX DOCs, it's easier to keep your entire organization on the same page - from product development to manufacturing, to service and support.

The complete portfolio of T-FLEX DOCs lifecycle applications helps your teams make good decisions for their tasks at-hand, while unifying the various work streams within a single source of product and process knowledge. T-FLEX DOCs is also fully integrated with our design products including T-FLEX CAD as well as third party products. By combining these tools you can realize operational advantages and acceleration of design processes.

Engineering Processes and Design Management

T-FLEX DOCs engineering process management solution allows you to integrate your engineering teams by bringing together the product designs within a single product data management (PDM) system. You can capture, manage and synchronize product design data from various major CAD systems, then automate your engineering change, validation and approval processes.

General Office and Desk Workflow

To maximize the value of your product data and increase your innovation potential, you can use T-FLEX DOCs software to unite diverse participants across various commercial and government organizations in an intuitive collaborative environment. T-FLEX DOCs supports global teaming by connecting every user's desktop, bringing people together with the tools and services they need to perform as a team and connecting them with the product knowledge of the extended enterprise to ensure that right decisions can be made at every decision point. This approach avoids rework, reduces cost and accelerates time-to-market.

Enterprise Knowledge Management and Archive

T-FLEX DOCs allows you to leverage product knowledge by applying it to automated business processes. You can manage your business initiatives throughout the lifecycle, synchronizing efforts, increasing productivity and achieving greater innovation. As a PLM platform, T-FLEX DOCs allows you to consolidate your product knowledge and processes, and implement domain and industry solutions that reduce your total cost of ownership and time-to-value.

Project Management, Cost and Resource Planning

T-FLEX DOCs brings project management and the product lifecycle together to enable your company to fully leverage its resources and prioritize your products so they can be aligned to drive your strategic business objectives forward.

Before making commitments and beginning the work, you can use T-FLEX DOCs to create what-if scenarios that consider schedule changes and supplemental resources for balancing capacity against the product roadmap. This allows you to validate the roadmap against actual organizational capacity.

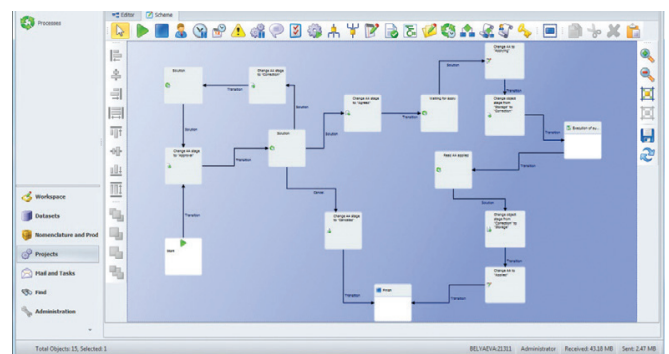
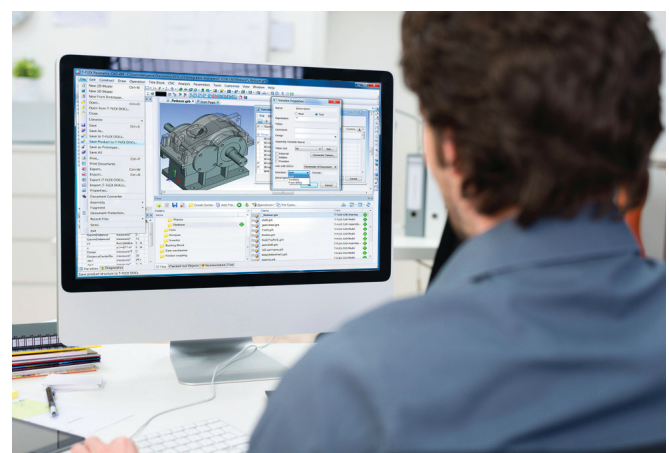
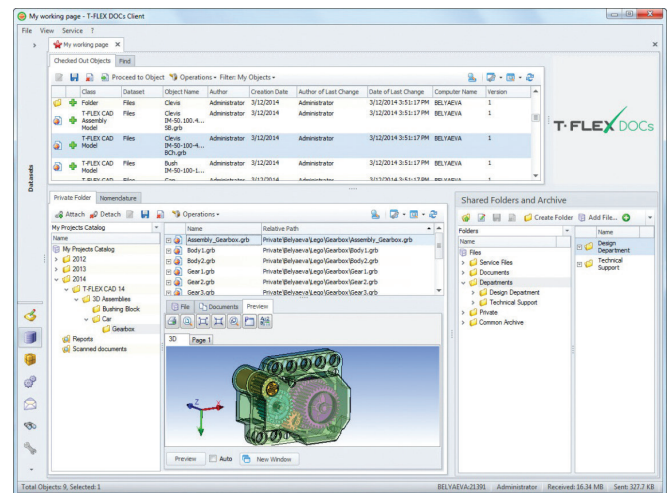



Mail and Tasks, Workflow Management

T-FLEX DOCs has all necessary functions of organizational and administrative management and allows you to combine various departments into a single business unit: from general office to design-engineering services. The system allows you to organize multilevel control of executive discipline, including: traditionally accepted simple and hierarchical resolution, automated notifications of performers and leaders at all phases of work, control of timing and controllers assignment. Workflow Management module is an important and integral part of many solutions built on T-FLEX DOCs platform. It is aimed at automation of user interaction during the execution of a wide variety of works. T-FLEX DOCs has special tools to issuing assignments and provide clear and fast operational control. The program includes, among other things, specialized calendar to not only see the target dates for all works and assignments, but also quickly create reminder alerts for yourself and record your activities.

Integration with ERP Systems

T-FLEX DOCs provides information to downstream applications, such as enterprise resource planning (ERP) systems. Operational data can be transferred to various ERP systems both through standardized XML exchange format files, and through the creation of specialized software modules. This functionality helps you to optimally implement T-FLEX DOCs into your ERP system landscape and ensure data consistency.

Managing Company Product Range, Corporate Data and Classifiers

T-FLEX DOCs helps to organize data spread across multiple databases and locations providing optimal solutions for data harmonization. Various types of datasets may be used to involve all type of objects and product structures into a uniform knowledge base of company's products and processes.

Product Structure Management, Bill of Materials, Configurations and Versions

T-FLEX DOCs single source of structured product and process information enables you to derive the right bill of materials (BOM) information relevant to your needs. Coupled with powerful capabilities to manage product complexity and variability, you can more easily manage product offerings, platforms and options.

T-FLEX DOCs enables you to create a generic product structure that you can use to manage all of the configurations that apply to a product platform, including definitions for the product families, variants and options that facilitate an affordable approach to mass customization.

Integration with Major MCAD Systems

T-FLEX DOCs has modules for integration virtually with all most popular design systems, including: T-FLEX CAD, SolidWorks, Autodesk Inventor, AutoCAD, PTC Creo and Siemens NX.

Customized Information Systems

You can extend T-FLEX DOCs with specialized custom applications that meet your unique PLM requirements while ensuring ease of maintenance and future upgradeability. Support for .NET API allows you to create scalable applications based on the standard .NET technology, supported by various programming languages and tools.

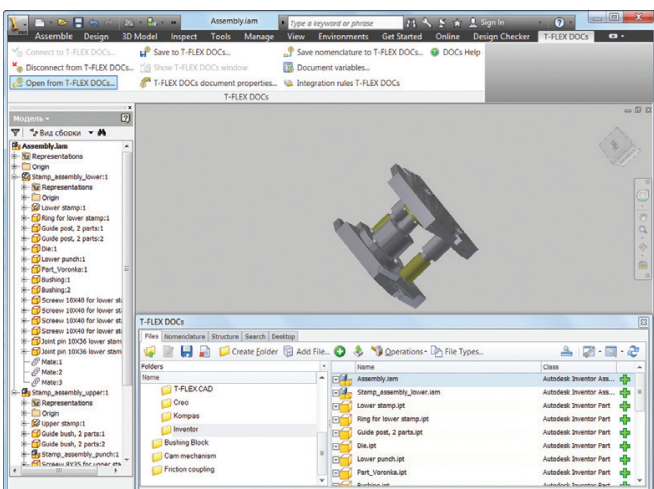
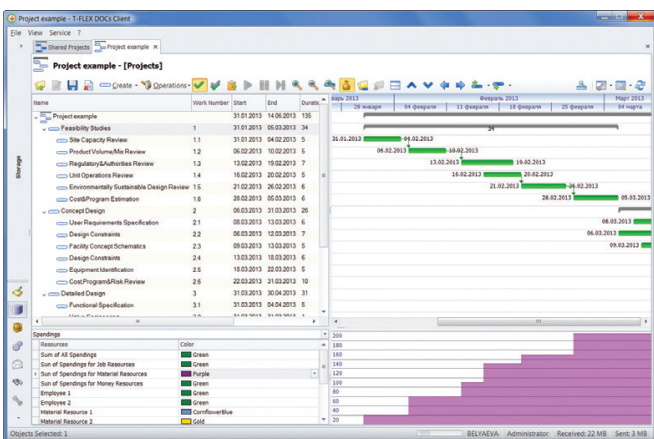
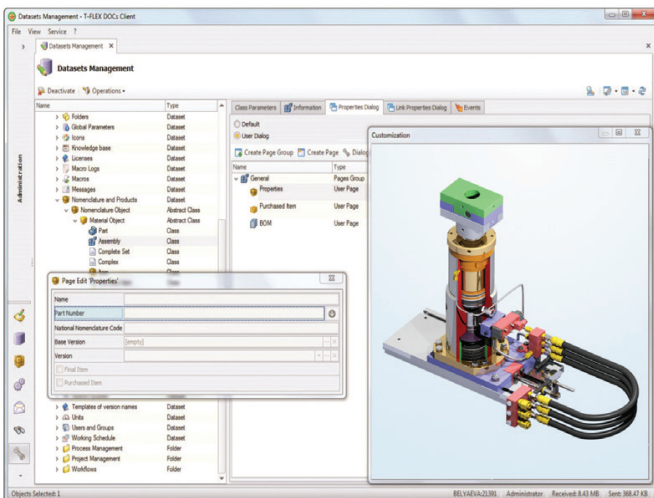

Top Systems is the leading developer of advanced, integrated CAD/CAM/CAE/PLM solutions for engineers and industrial designers.

Top Systems develops and distributes the T-FLEX product line, which is mainly targeted at the mechanical manufacturing industry, but also at other industries, in which design and manufacturing are tightly connected (wood, sheet metal, glass manufacturing industries, construction, etc...). Top Systems provides software solutions on various languages worldwide directly as well as through distribution partners. Headquartered in Moscow, Russia, Top Systems helps thousands of its clients make great products by optimizing their lifecycle processes, from planning and development through manufacturing and support.

The logo for T-FLEX is displayed in a light gray, sans-serif font. A teal-colored checkmark is superimposed over the 'X' in 'FLEX', extending from the bottom right towards the top right.

T-FLEX Parametric CAD, T-FLEX CAD, T-FLEX CAM, T-FLEX Analysis, T-FLEX Dynamics, T-FLEX DOCs are trademarks of Top Systems.

All other logos, trademarks or service marks used herein are the property of their respective owners.

Copyright © 2015 Top Systems, All rights reserved.

Top Systems

1 Vadkovskiy per.
Moscow 127055, Russia
tflex@topsystems.ru
www.tflex.com