

# Go Glass Project Fold Glass Door System

Enjoy open plan living with the versatility of separate rooms with this frameless folding glass door system.

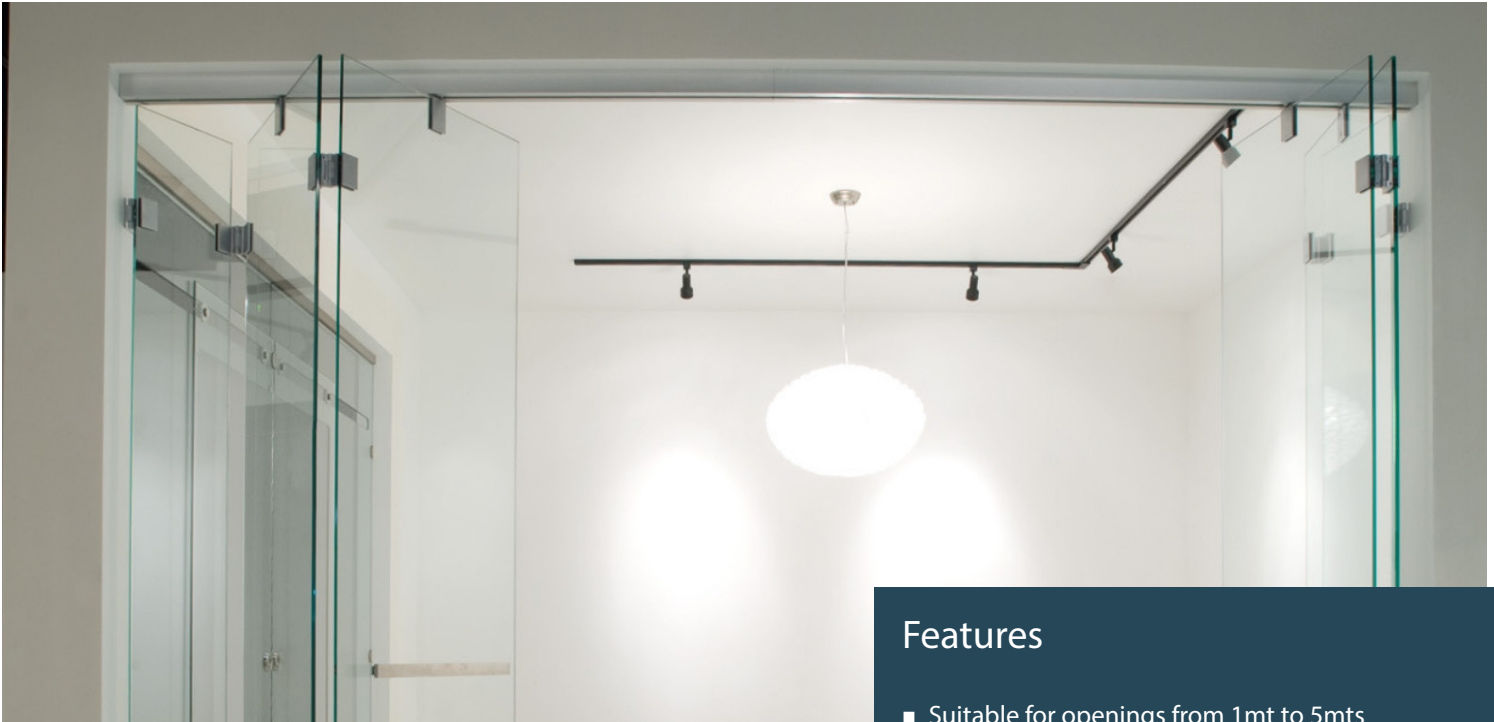

## Applications

- Glass partitioning wall system
- Suitable for living/dining rooms
- Create a spare bedroom
- Perfect for office partitions

## Features

- Suitable for openings from 1mt to 5mts
- No floor track required
- Magnetic hinge technology holds doors in open position, no need for lock
- Available single or double sided
- Glass choices include clear, obscure, etched design. Also available with LED edge lit technology.
- Easy to install, no specialist fitting required.

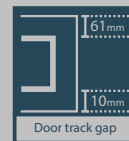
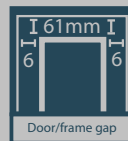
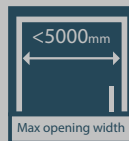

# Technical Specification

## Breakdown

- 1** Make the most of space and light in commercial and domestic settings with Project Slide bi-fold and tri-fold frameless glass door system. Top hung from a slimline top track in satin finish the doors are suspended and slide and fold from the top meaning that there is no need for a floor channel to cause obstructions and spoil the aesthetic.
- 2** The system's sleek and low profile design is supported by a sturdy aluminium sliding profile, ensuring maximum stability. A magnetic catch system in the hinge holds the door in place when closed, this means that the system can achieve a fixed zero position when closed without the need for additional locking mechanisms.
- 3** Glass is UK Toughened 10mm thickness and is available in a range of options which include clear, obscure etched, sandblasted design and can also utilise LED edge lit technology.
- 4** Easy to install and supplied in component form with full fitting instructions.  
  
Tight opening size is required for manufacture all tolerances are made to fit.  
  
Opening width x FFH (Finished floor to ceiling height)

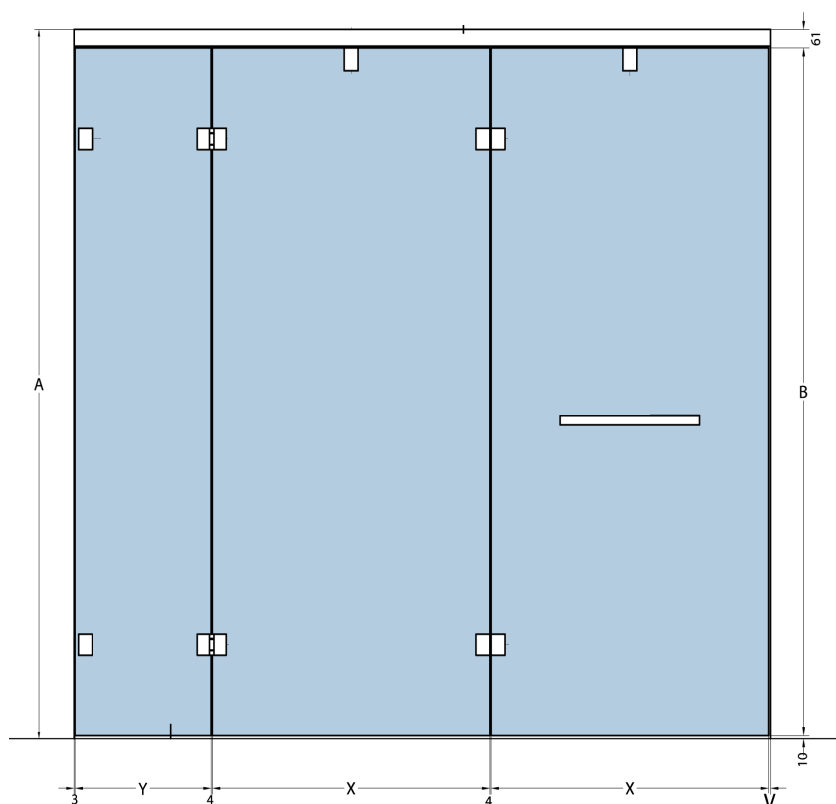
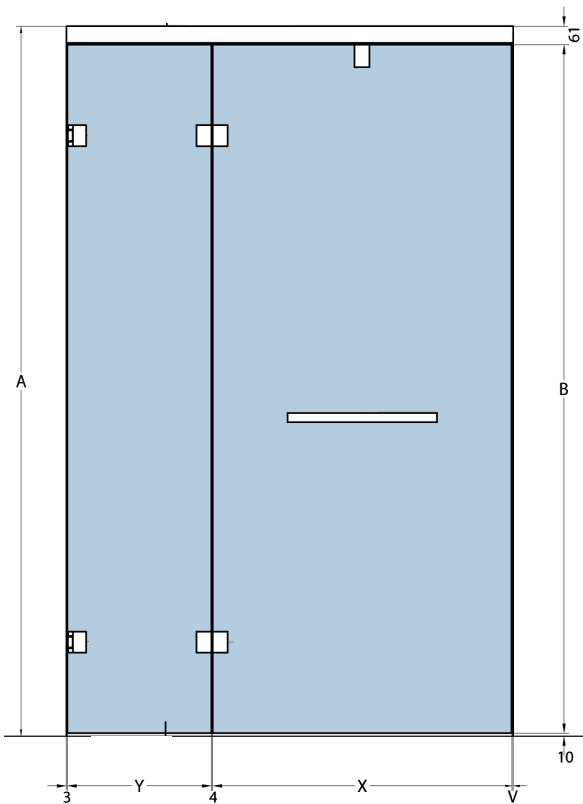

Clear



Low iron



Obscure sandblasted

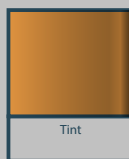

Tint



Project design  
(28 designs)

[goglass.co.uk](http://goglass.co.uk)



### Fitting set for 2 leaf arrangement

Size maximum 1600 x 2500 mm · Size minimum 1000 x 2100 mm · Weight maximum 100 kg · for 10mm toughened glass · silver anodised

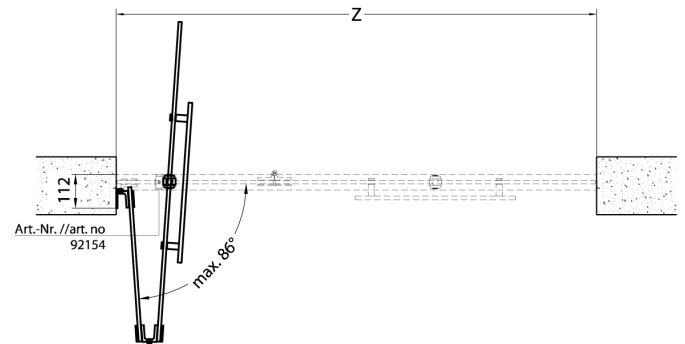
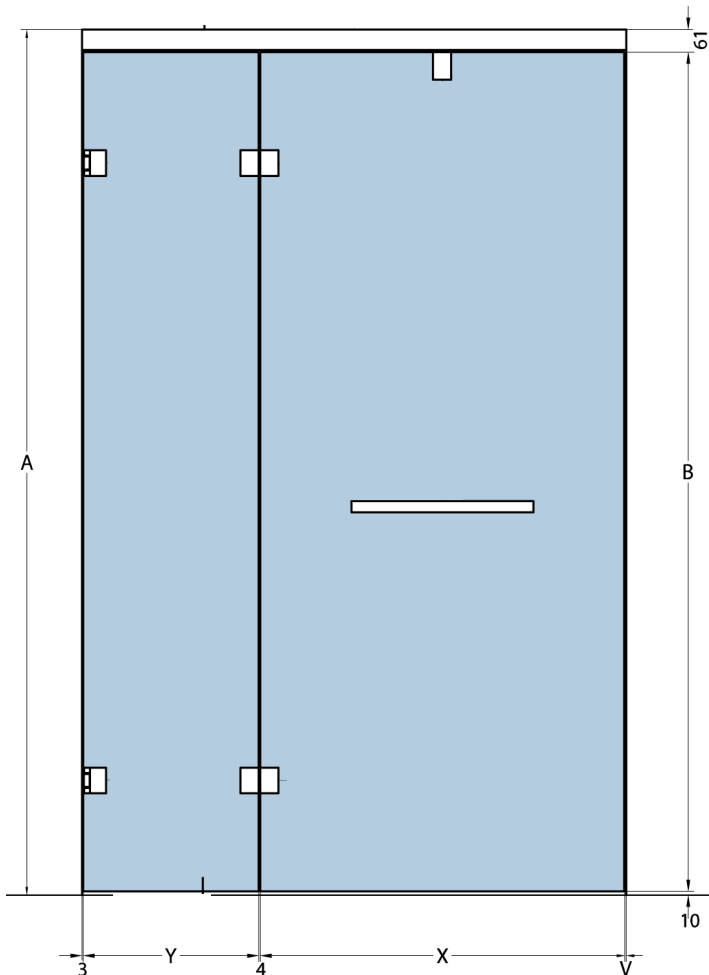

Z :	1600 - 1500	1499 - 1200	1199 - 1000	1600	1500	1400	1300	1200	1100	1000	mm	
Y =	$(Z / 3) - 12$	$(Z / 3) - 13$	$(Z / 3) - 14$	521	488	454	420	387	353	319	mm	
X =	$(Z / 1,5) + 2$			1069	1002	935	869	802	735	669	mm	
V :				3	3	4	4	4	5	5	mm	
A :	max.			2500	2500	2500	2400	2300	2200	2100	mm	
B =	A - 71			max.	2429	2429	2429	2329	2229	2129	2029	mm

[goglass.co.uk](http://goglass.co.uk)

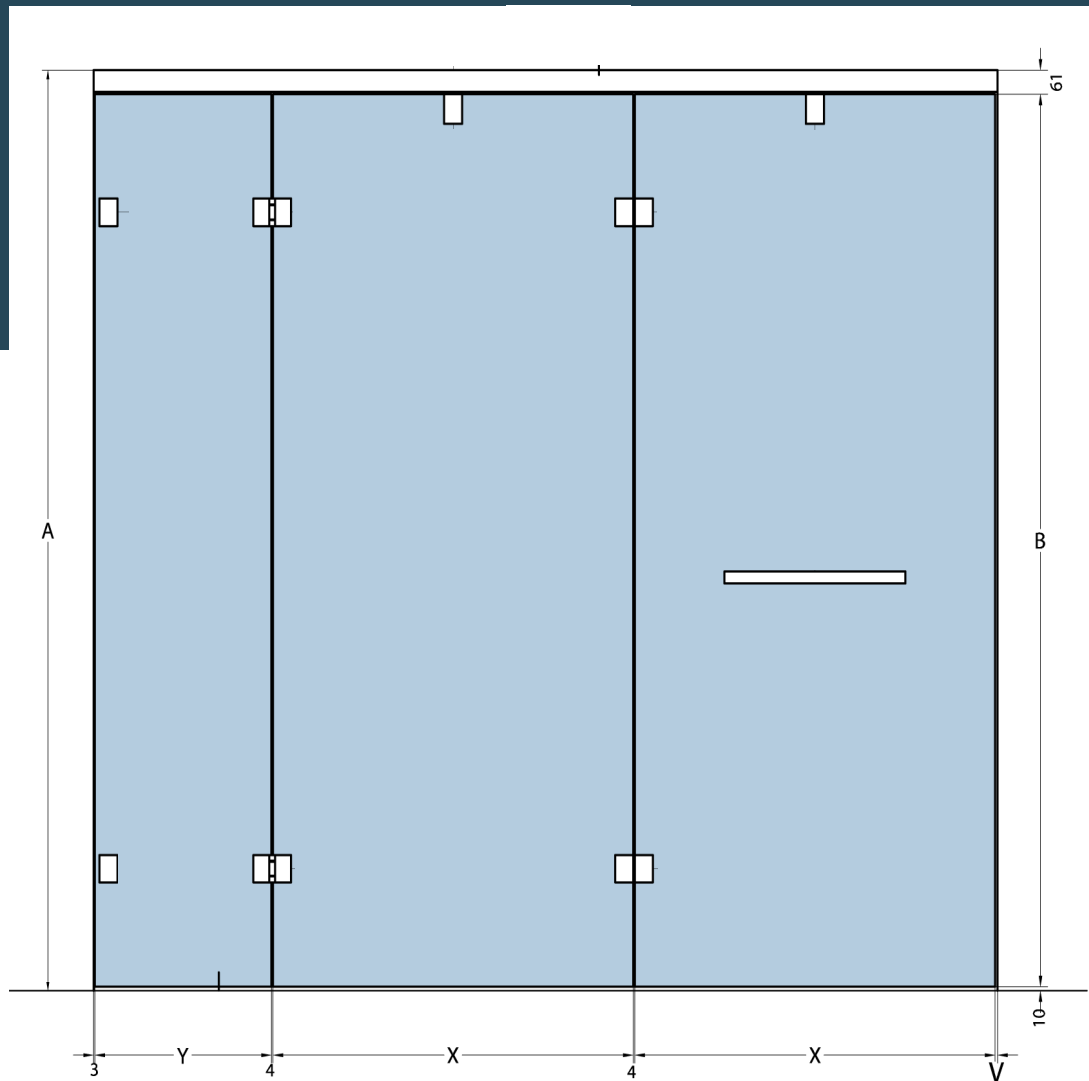

### Fitting set for 3 leave arrangement

Size maximum 2500 x 2500 mm · Size minimum 1500 x 1900 mm · Weight maximum 160 kg · for 10mm toughened glass · silver anodised

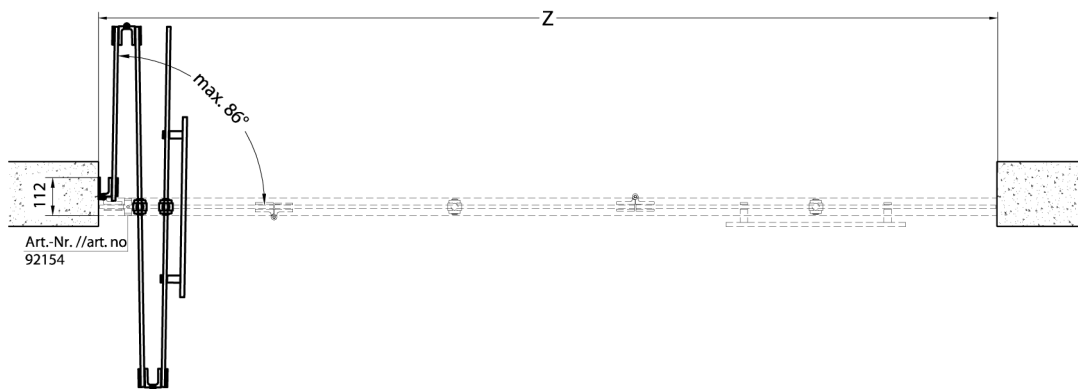

Z :	2500 - 2200	2199 - 1800	1799 - 1500	2500	2400	2300	2200	2100	2000	1900	1800	1700	1600	1500	mm
Y =	$(Z / 5) - 13$	$(Z / 5) - 14$	$(Z / 5) - 15$	487	467	447	427	406	386	366	346	325	305	285	mm
X =	$(Z / 2,5) - 2$			998	958	918	878	838	798	758	718	678	638	598	mm
V :				6	6	6	6	7	7	7	7	8	8	8	mm
A :	max.			2500	2500	2500	2500	2500	2400	2300	2200	2100	2000	1900	mm
B =	A - 71	max.		2429	2429	2429	2429	2429	2329	2229	2129	2029	1929	1829	mm