



Triple glazed windows

Enhanced **energy** efficiency

Surpasses current **'A+'** rating requirements

Your Choice

Triple glazing is the key to reducing heat loss through your windows and will help to reduce your fuel bills

Enhanced energy efficiency - with appropriate argon-filled triple glazed units, Matrix 70 can achieve U-values as low as 0.8

Matrix 70



Matrix FS70



Infinity



Letting in light used to be the sole purpose of glazing, but now, triple glazing can contribute to the thermal performance of your home and help save you money on your heating bills.

For this reason, colder climates that suffer from harsh winters, such as Canada and the Scandinavian countries, triple glazing has been used for decades as standard.

Triple Glazing is only a single part of your windows and doors and needs to be combined with a quality and energy efficient PVCu to give you its full benefit.

Using VEKA, the UK and world's number one extruder of PVCu profiles, in unison with our Triple Glazed units, provides you with a window and door that is at the forefront of energy saving fenestration products.

The VEKA range of profiles will also meet all your needs by providing windows and doors in a wide choice of styles and colours. Whether you are matching existing windows and doors or choosing the one that best suits your home, we can offer you the choice of Chamfered Matrix 70 or Sculptured Matrix FS70 profiles.

Moreover, if you are concerned about the environment and wish to reduce your carbon footprint further, you could choose the Chamfered Matrix

Infinity profile with its 80% recycled content and 100% virgin PVCu exterior. The Infinity profile helps you to reduce the natural resources used whilst ensuring you get a product that looks great and comes with a 10 year guarantee.

The benefits of triple glazing do not stop there. By using the extra pane of glass you get the added benefit of improved sound insulation over standard double glazing. This can be improved further by using different thicknesses of glass in the sealed unit but will greatly increase the unit's weight causing restrictions on the size of opening window.

Incorporating a toughened pane of glass inside the sealed unit improves the overall security of any double glazed window. The middle pane of toughened glass also combats stress cracks that can occur due to heat build up on standard float glass if used inside the sealed unit.

The Facts

Triple glazing is well established in many parts of Europe and is becoming increasingly popular in the UK. Windows are one of the most exposed parts of a house.

According to the Energy Saving Trust, a staggering 26% of all domestic heat loss escapes through the windows. Installing energy efficient windows is essential to help keep the cost of your energy bills down.



- Triple glazed units are up to 40% more thermally efficient than double glazed units.
- A window fitted with triple glazed units exceeds the current 'A+' window energy rating.
- The physics of triple glazing has been calculated in Germany by the PassiveHaus Institute. It has shown what happens to the internal surface temperatures on various forms of glazing when it is severely cold outside and the internal temperature is 21°C:
- Single-glazed window – internal surface temperature is around 1°C.
- Typical double-glazed window fitted 10 years ago – surface temperature is around 11°C.
- Triple-glazed window with a centre-pane U-value of just 0.68 – temperature is around 18°C.
- Triple glazed units will not overheat your home. The level of solar gain is actually less than double glazed units due to the extra pane of glass and additional cavity. However, the overall energy balance of a triple glazed window will ensure that more heat is retained in the room in the colder months of the year.
- Enhanced security due to the extra pane of toughened glass ensures that your windows are less easy to break through.
- Improved sound insulation to help reduce external noise penetration.
- We can also offer a 28mm triple glazed unit filled with Krypton gas which achieves a centre pane U-value of 0.6. We offer this smaller unit because some of our range will not accept the wider unit sizes. Krypton gas works better in smaller air-gaps than Argon, but is more expensive. Either way we can provide a glazed unit to meet all of your requirements.



BS 7412
KM 517504



ISO 9001 2000
FM 518992

Heat loss

The heat losses through a building's windows make up a massive part of the total energy/ electricity bill for a standard household.

In a normal house the costs for this particular heat loss can reach around 15-20% of the total bill and it can even reach up to a stunning 33% depending on the circumstances.

The thermal pictures opposite show the property before and after thermally efficient triple glazing was installed.

The picture on the left shows the external glass temperature of the hall at 3.4°C and the living room glass at 1.3°C ; this shows that heat is being lost.

The picture on the right shows the external glass temperature of the hall at -5.2°C and the living room glass at -4.5°C ; this clearly demonstrates no heat is being lost and all the heat is reflected back into the home to help reduce the cost of your heating bills.



For the best profile... anywhere

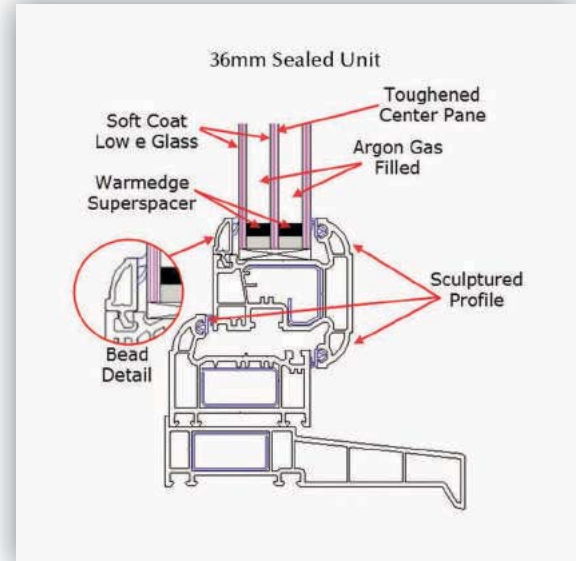

VEKA Matrix FS70 Fully Sculptured 36mm triple glazed 0.76 U-value. Whole window 1.1 U-value

Before



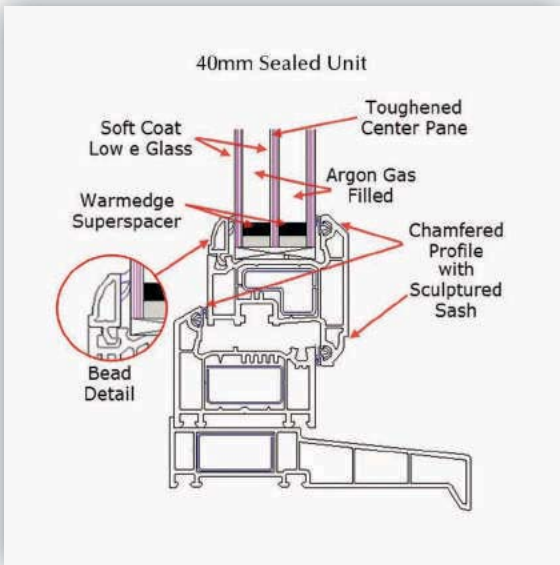

VEKA Matrix 70 Sculptured Sash 40mm triple glazed 0.68 U-value. Whole window 1.0 U-value

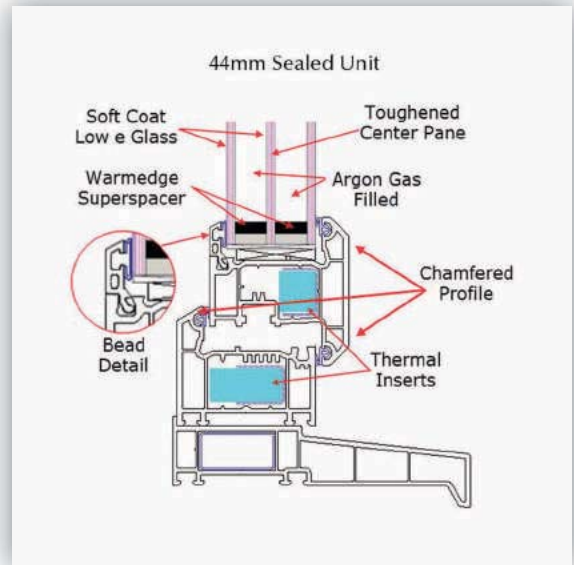

VEKA Matrix 70 Chamfered 44mm triple glazed 0.62 U-value. Whole window 0.8 U-value

After

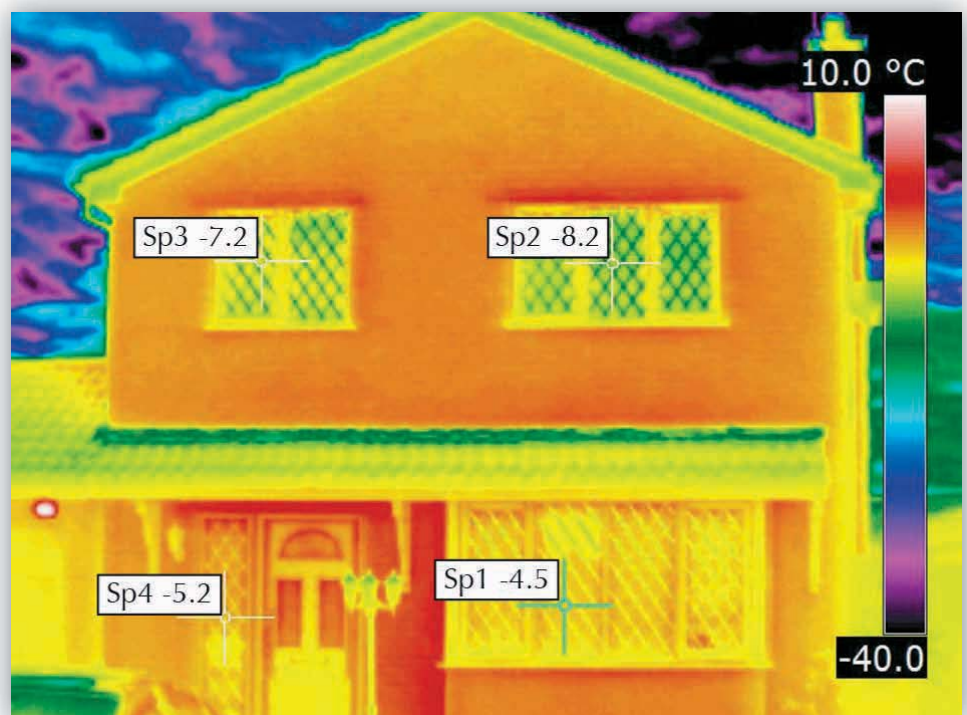
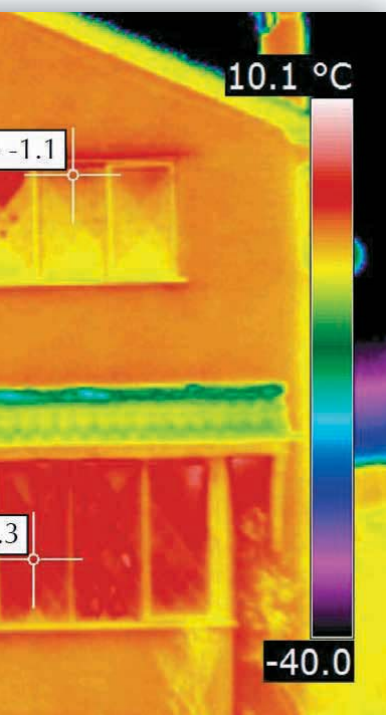



Triple glazed window System from **VEKA**

Matrix 70 System

Matrix FS70 System

Matrix Infinity System

Surpasses current '**A+**' rating requirements

Range of colours including 18 foiled
woodgrain finishes



For the best profile... anywhere

All details are correct at the time of going to print; Glazerite Windows Ltd reserves the right to amend without prior notice.

Do not copy or use without permission of Glazerite Windows

Glazerite Windows Ltd 2013

Re-Order GWTGW1