

**Metalliferous Mining - Processing
Electrowinning and Smelting
Resource Book**

Table of Contents

TABLE OF CONTENTS	2
INTRODUCTION TO ELECTROWINNING AND SMELTING	3
<i>What is this module about?</i>	3
<i>What will you learn in this module?</i>	3
<i>What do you have to do to complete this unit?</i>	3
<i>What resources can you use to help?</i>	3
INTRODUCTION	4
ELECTROWINNING THEORY	5
FACTORS AFFECTING CELL PERFORMANCE	7
ELECTROWINNING CIRCUIT CONFIGURATION.....	9
CALCINING	10
GOLD SMELTING	11
SMELTING FURNACE	13
NOTES	ERROR! BOOKMARK NOT DEFINED.

Introduction to Electrowinning and Smelting

What is this module about?

This unit is about how we manage electrowinning and smelting within the processing plant

What will you learn in this module?

When you have completed this module, you will be able to:

- Explain the electrowinning theory
- List the factors which affect electrowinning cell performance
- Draw the electrowinning circuit configuration and label its components
- Explain calcining and its purpose
- Explain the purpose of smelting
- List the smelting fluxes and briefly describe their purpose
- Draw a smelting furnace labelling its components

What do you have to do to complete this unit?

You will need to complete all the training tasks in your workbook, the review exercise and the assessment given to you by your supervisor.

Discuss the competency standards for this unit with the Training Coordinator or your supervisor.

What resources can you use to help?

If you need more information about topics in this unit, then you should approach:

- Your work mates and supervisor
- The training coordinator
- Metallurgists

Introduction

Electrowinning and smelting are the final stages of gold production.

The concentrated gold solutions produced in the elution circuit (pregnant eluate and by the Sunrise Reactor, are passed through the electrowinning cells which converts the gold ions (charged gold particles) in the solution into solid gold.

The process of electrowinning simply involves passing an electric current through the electrolyte (eluate). Electrons (electricity) pass from the cathode (negative electrode), through the solution and into the anode (positive electrode), completing the electrical circuit. The current causes the gold to plate out onto the steel wool cathodes.

Upon the completion of an electrowinning batch, the cathodes are removed from the cell for calcining and smelting. Calcining involves prolonged heating of the cathodes at 750°C, the purpose being to oxidise the impurities (iron, copper etc) that are present with the gold so that they can be 'slagged off' in the subsequent smelt.

During smelting the calcined cathodes are heated in a gas-fired furnace to a molten state in the presence of slag-forming fluxes. The slag captures the impurities and floats upon the molten gold. The entire furnace charge is then poured into moulds, resulting in bars of gold bullion ready for shipment.

Electrowinning Theory

Gold is recovered from pregnant (gold bearing) solution by the process of electrowinning. An electric current is passed through the solution causing solid gold to plate out on steel wool cathodes.

Electrowinning is performed in cells, constructed of non-conducting plastic material. The cell contains a set of cathodes (negative electrodes) and anodes (positive electrodes) immersed in the gold bearing eluate delivered from the elution circuit, or Sunrise Reactor. The eluate acts as a conductor between the cathodes and anodes. When the rectifier is switched on the electrowinning circuit is complete and current begins to flow from the cathodes to the anodes.

Cathode Reaction - Gold Deposition

Gold is electrolytically displaced from the alkaline cyanide solution (pregnant eluate) and deposited on the cathode surface according to the reaction:



The rectifier acts, as a battery supplying the electrons (electricity) required for the reaction to proceed. An electron is the basic unit of electricity, The gold cyanide complex is 'split' into a solid gold particle attached to the cathode and cyanide ions that remain in solution.

The cathodes are constructed from mild steel wool woven around a stainless steel frame for support The cathodes are contained in plastic boxes which also provides support for the steel wool and prevents the cathodes from touching the anodes which would short circuit the system.

The steel wool has a high surface area, which means a large number of sites for the deposition reaction to take place. This leads to higher efficiency and reduces the time required for electrowinning.

Once the cathodes are laden with the required amount of gold they are removed from the cells for calcining followed by smelting to produce gold bullion.

Cell Anodes

The anodes, or positive electrodes, are made of stainless steel mesh. The anode does not collect gold but is necessary for the current to flow, completing the electrical circuit within the cell.

It is important that the eluate has a high pH, as the anodes will corrode at pH less than 12.5.

Oxygen gas produced by the oxidation of water is the main reaction occurring at the anode.

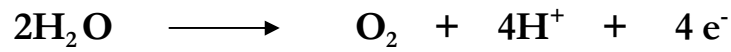

Water \longrightarrow Oxygen + Hydroxyl Ions + Electrons

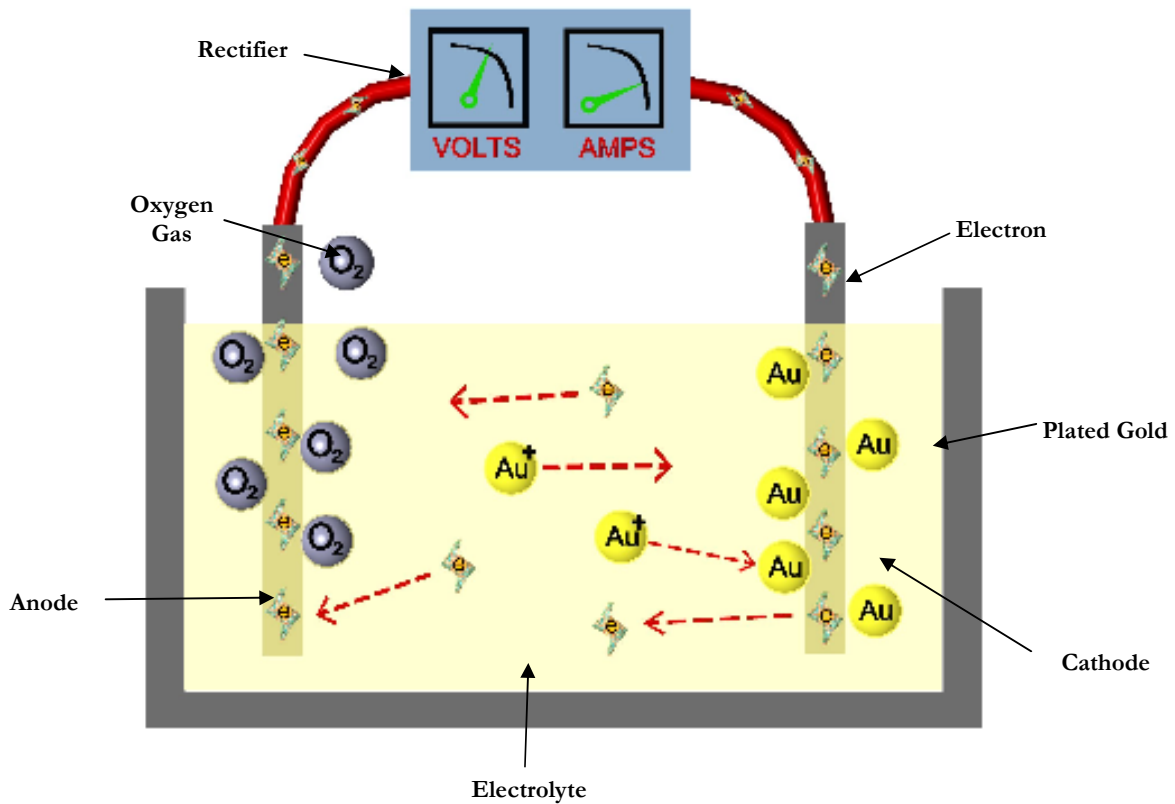

Turn to your workbook and complete Training Task 1

Factors Affecting Cell Performance

Cell Voltage

The voltage and current that must be applied to a cell for most efficient gold recovery depends on a number of factors including eluate conductivity, pH, temperature and the concentration of all the different species in solution. At SDGM a cell voltage of around 3.5V is applied for optimum gold recovery.

Cell Current

The cell amperage (amps) is basically a measure of the amount of current, or electrons, flowing through the cell. As one electron is required for the deposition of one gold atom (see reaction above), then the amount of current determines how much gold can be electrowon.

The rate of gold deposition increases with increasing current, up to a limiting amount, at which point the maximum cell current efficiency is obtained. Above this point the current is consumed by other side reactions such as the evolution of hydrogen and the deposition of other metals such as copper, and does not contribute to further gold deposition.

The required amperage is determined by the plant metallurgists and entered into Citect as a control set point. The output of the rectifiers is maintained at the set point by a control loop. The optimum amperage is somewhere in the range of 30 to 50 amps per cathode.



Electrowinning Cell

Solution Conductivity

The conductivity of the eluate (i.e., how well the solution conducts electricity/how well electrons flow through the solution) also affects cell performance. Caustic is added to the eluate prior to electrowinning to improve conductivity to enhance cell performance.

As mentioned before, caustic is also added to raise the solution pH to prevent the corrosion of the anodes, and limit the evolution of hydrogen gas.



Steel Wool Cathode

Other factors

- **Gold Concentration**

Higher gold concentrations in the eluate enable a faster rate of gold deposition.

- **Electrolyte Temperature**

Elevated eluate temperatures marginally increase both the rate and efficiency of gold deposition.

- **Cathode Surface Area**

Electrowinning efficiency optimised by maximising the cathode surface area exposed to the solution.

- **Eluate mixing and Short-Circuiting**

Enhancing the degree of mixing and minimising solution Short-Circuiting within the cell would improve the rate of deposition. However, to alter the solution flow characteristics would require the cell to be physically modified or the flowrate to be altered.

- **Cyanide Concentration**

Generally, the higher the cyanide concentration in the eluate, the higher the cell operation voltage required for optimum cell performance.

Electrowinning Circuit Configuration

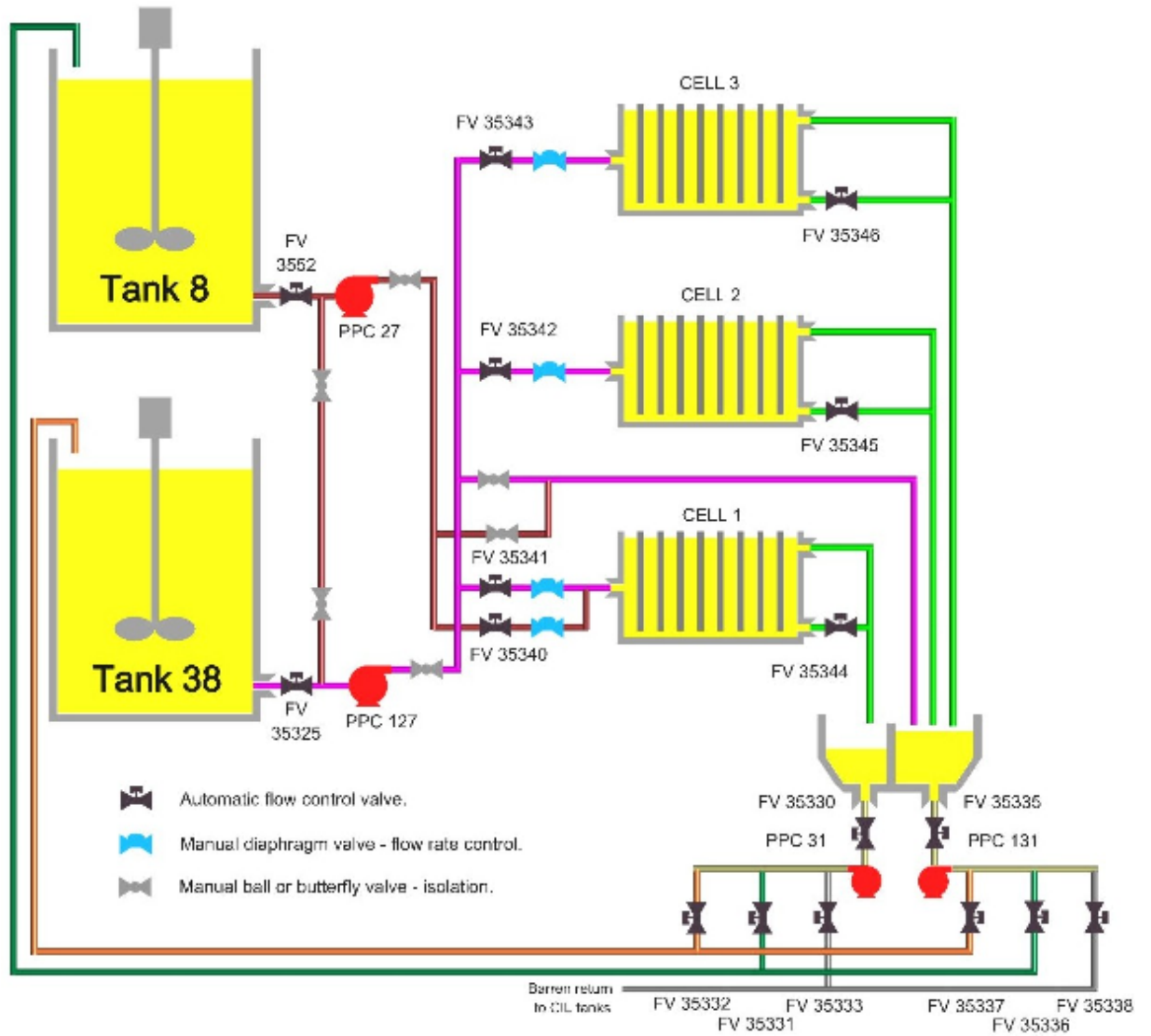

Turn to your workbook and complete Training Task 2 & 3

Calcining

Prior to smelting the cathodes are firstly calcined in an oven at 750°C. The purpose of calcining is to oxidise the steel wool and base metal impurities such as copper. The oxide impurities are then easily removed into the slag during the subsequent smelting process.

Without first calcining the cathodes, smelting would require large quantities of flux, a larger furnace heat input and would take a lot longer.

The loaded cathodes are hoisted from the cell to a table where the steel wool is removed and placed onto high temperature stainless steel trays, which are then placed into the calcining oven.

It is important the cathodes are not packed too tightly into the trays, as an adequate flow of air must be provided to all regions of the material to supply oxygen to oxidise the impurities. The cathodes are calcined overnight to provide sufficient time for complete oxidation. A controller on the oven maintains the temperature at the set point displayed/entered on the panel.



Calcine Oven

Gold Smelting

Purpose of Smelting

Smelting is the final stage in the production of tile gold. The purpose of smelting is to remove the metallic and other impurities into the slag phase, and produce a gold-silver bullion containing typically >95% precious metals.

The smelted product, called dore bullion, is unsuitable for direct sale and is hence sent to a refinery for further processing to produce >99.6% pure gold bullion

Smelting is achieved by heating the calcined cathodes in the presence of slag-forming fluxes, at temperatures in excess of the melting point of any of the components in the charge. This smelt temperature is maintained for a period of time to ensure complete separation of the impurities into the slag. The molten gold and silver form an alloy that is heavier than the slag and hence sinks to the bottom of the smelting crucible. The gold-silver alloy is then cast into bars by pouring the molten charge out into moulds.

Smelting Fluxes

Fluxes are materials that are added to the calcine material to complete the oxidation of the impurities and remove them from the gold

The success of the smelt, i.e., the efficiency of the separation of gold and the impurities, depends on the quality of the slag that is formed. Ideally the slag should contain no gold (or silver) and have maximum recovery of the impurities.



• **Silica : SiO_2 : MP 1723°C**

Silica forms the basis for the flux as it has the capability to dissolve most metal oxides. The silica reacts with and captures the base metal oxide impurities

• **Borax : $\text{Na}_2\text{B}_4\text{O}_7 \cdot 10\text{H}_2\text{O}$: MP 742°C**

Borax acts in the same way as silica in its ability to capture base metal oxides. Silica has a high melting point and tends to form a highly viscous slag, which may entrain precious metals. The addition of borax reduces both the melting point and viscosity of the slag.

• **Nitre : KNO_3 : MP 339°C**

Nitre is a powerful oxidising agent, which is added to oxidise non calcined iron and other unoxidised species (e.g. base metals). The use of oxidising agents during smelting requires care since silver can be oxidised and lost into the slag. Oxidising agents will also attack the crucible material

• **Fluorspar : CaF_2 : MP 1380°C**

Reduces slag viscosity.

• **Soda Ash : Na_2CO_3 : MP 852°C**

Improves slag clarity and decreases viscosity.



The calcine and fluxes are mixed together and then added to the hot crucible. The proportions of flux to calcine material will vary depending on the ore. At temperature the fluxes form a molten slag floating on top of the liquid gold. The molten gold is then poured into moulds. Once the slag has cooled it is returned to the milling circuit.

Smelting Furnace

A cylindrical firebrick lined furnace is installed in the goldroom. The furnace is LPG fixed at the base and has a hydraulic rating mechanism for pouring.

A crucible sits inside the furnace into which the calcine material and fluxes are placed. The crucibles are made of refractory ceramic clays to be able to withstand the intense heat of the furnace, molten metal and slag.

The charge is poured into cast iron moulds, and the gold sets into bars. The sides of the moulds are sloped inwards for easy removal of the solidified gold bars. Any slag remaining on the bars is removed with a needle gun in the quenching bath.

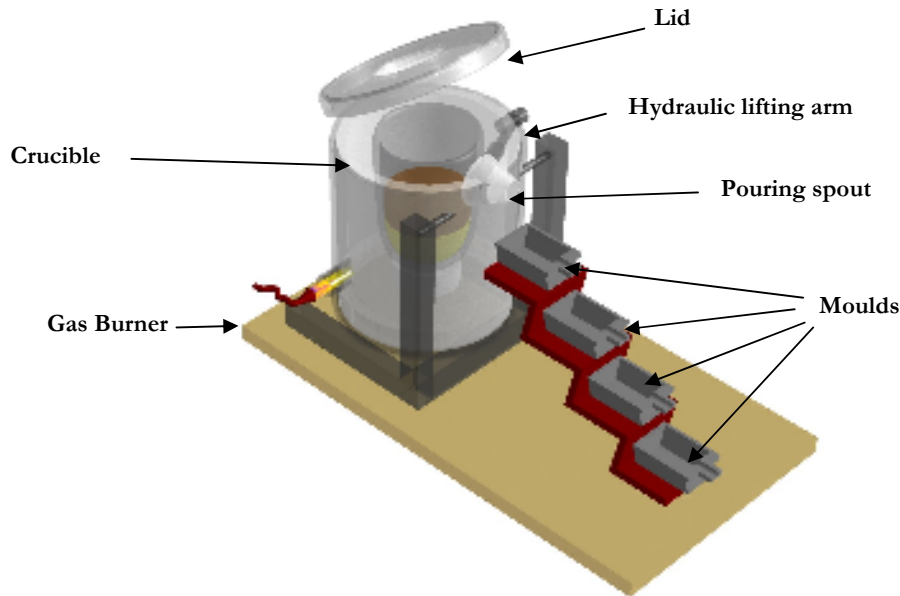

Smelting Furnace