

NOTE:
 (**) CONNECT "MO" TO GROUND IF SOLID GROUND IS PROVIDED.
 DO NOT CONNECT "MO" TO GROUND IF NEUTRAL IS CONNECTED TO GROUND.

Title ECBAB V3.5/ER WIRING DIAGRAM: VVVF + MZ V3.5 ER + RESCUE DC AUTO DOOR SUPPLY & OUTPUTS		
Size	Number	Revision
B		
Date:	10/26/2017	Sheet 1 of 3
File:	C:\Users\... \VVVF_SUPPLY.SchDoc	Drawn By:

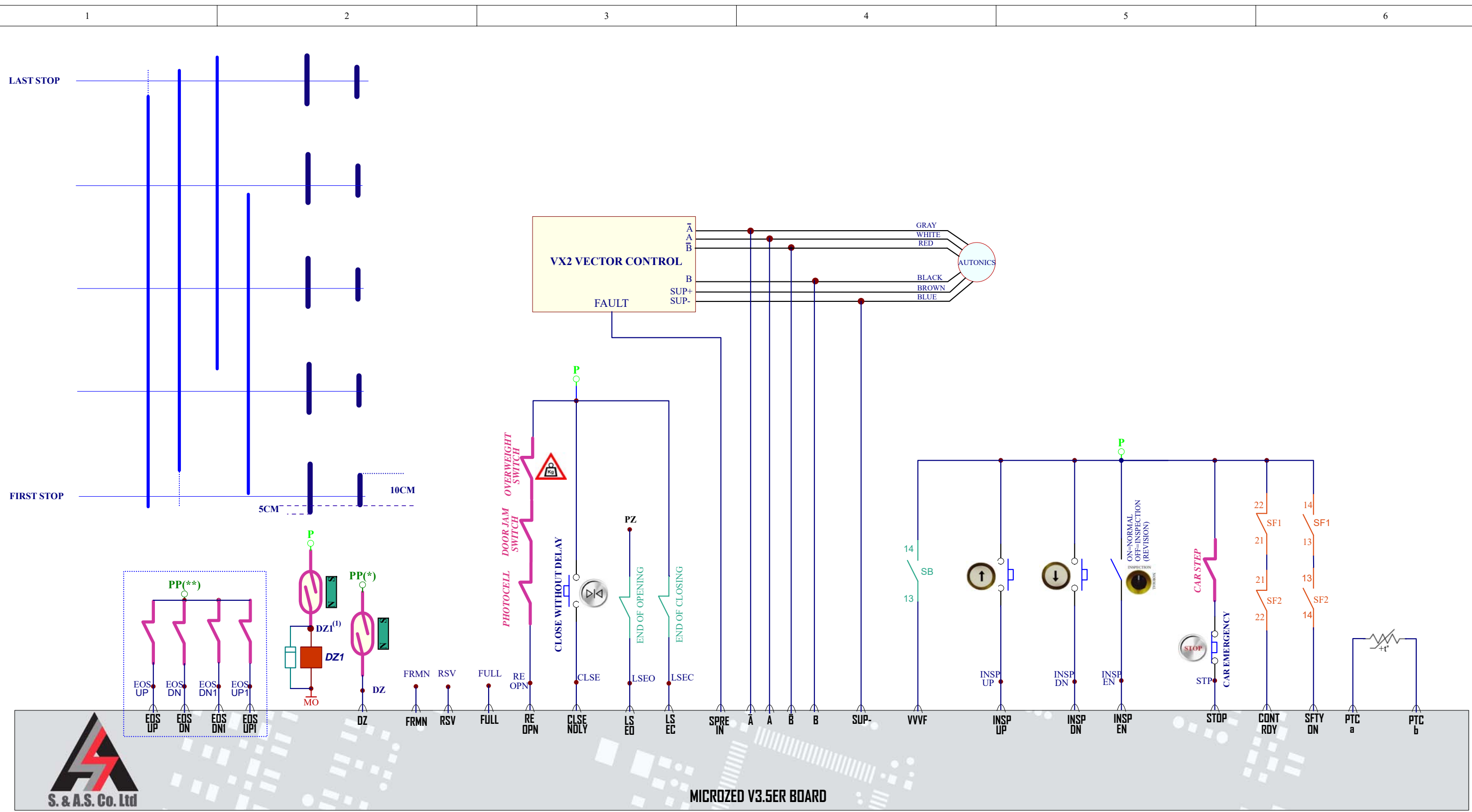

MICROZED V3.5ER BOARD

Note:
 (1) DZ1 is recommended for preopening
 (*) "PP" ONLY FOR MAGNETIC SWITCHES.

Title ECBAB V3.5/ER DIRET APPROACH WIRING DIAGRAM: INPUTS		
Size B	Number	Revision
Date: 10/26/2017	Sheet 2 of 3	
File: C:\Users\...VVVF_INPUTS.Sch	Drawn By:	

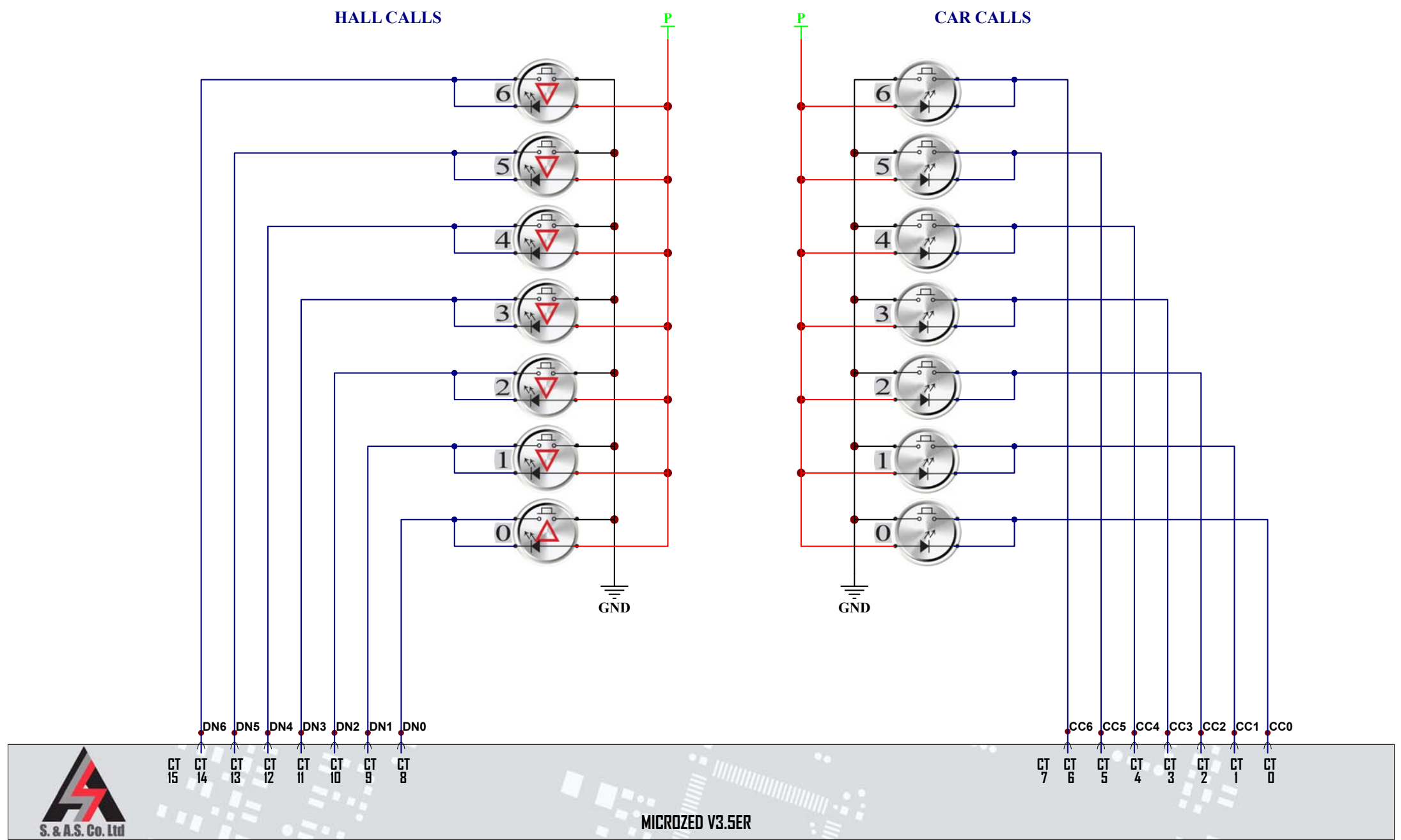

Title		
MICROZED V3.x WIRING DIAG: CAR CALLS & LANDING CALLS WITH EXTENSION		
Size	Number	Revision
B		
Date:	10/26/2017	Sheet 3 of 3
File:	C:\Users\... \VVVF CALLS.Sch	Drawn By: