

CITY OF EDMONTON
LANDSCAPING REQUIREMENTS
(PER DWELLING):
2 DECIDUOUS TREES
1 CONIFEROUS TREE
6 SHRUBS

LOWEST OPENING
ELEVATION AT THE
BUILDING 680.40

LOWEST BOTTOM
OF FOOTING 677.95

WING WALLS & OR
RETAINING STRUCTURES
MAY BE REQUIRED FOR
DRAINAGE PURPOSES

THIS PLAN IS TO BE USED AS A
GUIDE ONLY. ALL MINIMUM SIDEYARD
DISTANCES MUST BE VERIFIED BY
STANTEC GEOMATICS.

DRAINAGE TYPE – STANDARD SPLIT
WALKOUT BASEMENT

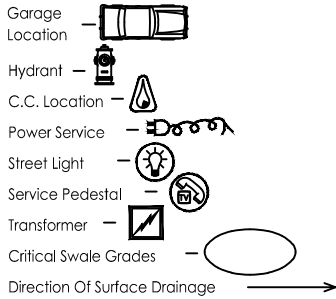

House Type _____
 Finished Floor _____
 Bottom Footing _____
 Finished Grade Front _____
 Finished Grade Back _____
 Bottom Back Door Sill _____
 Bottom Bsm't Window _____
 Top Conc. Bsm't Wall _____
 Finished Garage Floor _____
 Sanitary Sewer Invert 80.08
 JOIST _____ CONC.WALL _____ FOOTING _____

SCALE 1 : 300 RSL

LOT 7 PUL LOT 70 MR

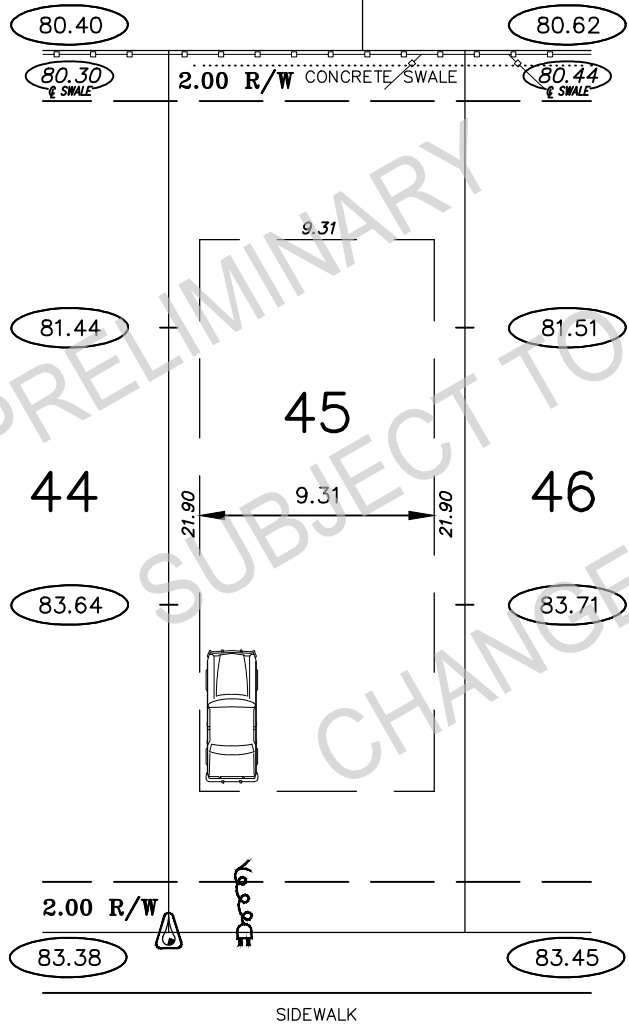

FRONT

LOT AREA = 411.25m²

Foundation Wall Height: ' "

*It is the responsibility of the builder to contact the soils consultant to determine if there are any special considerations pertaining to house foundation construction.
 *The elevation of this house has been designed so that it will be in conformance with the lot grading plan.
 *This plan is subject to the approval of the local approving authority and the agent responsible for the architectural control guidelines.
 *Stantec Geomatics will accept no responsibility for any costs incurred due to an error or omission on this plan if construction starts prior to the subject approvals.
 *All dimensions and services shown must be confirmed by contractor prior to excavation.
 *All distances shown are in metres and decimals thereof.
 *This Plot Plan is the property of Stantec Geomatics. It is forbidden to use this Plot Plan for survey layout of the building location and/or elevation without prior written consent from Stantec Geomatics.



Stantec Geomatics Ltd.
10160-112th Street NW
Edmonton, Alberta, Canada
T5K 2L6
Tel. 780-917-7000
Fax. 780-917-7289
www.stantec.com

Legal Description
LOT 45 BLOCK 5 PLAN UN-REG
KESWICK
Municipal Address
EDMONTON
Builder
Title
Plot Plan
Your File:
RL 04/04/18 BP