

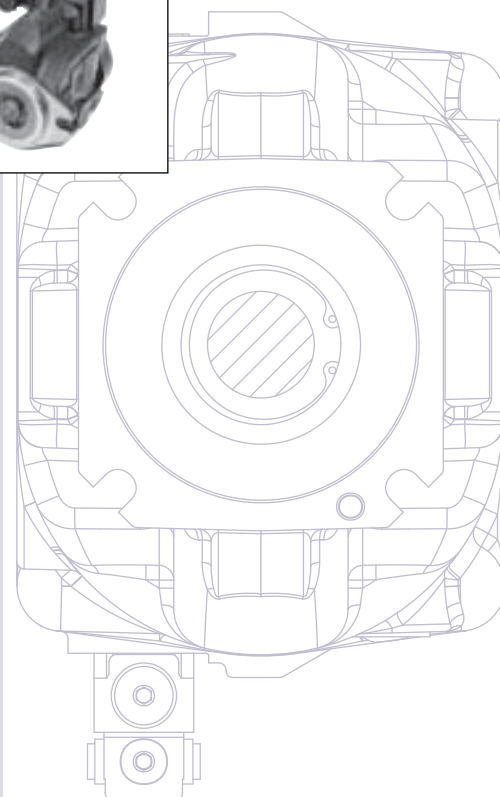

Series 45 Axial Piston Open Circuit Pumps

Technical Information

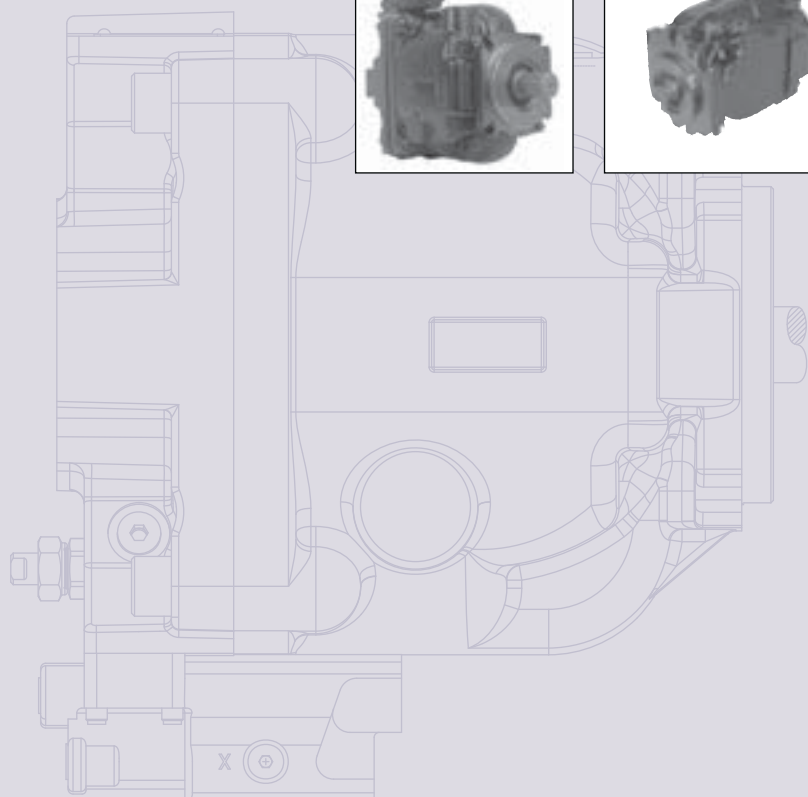
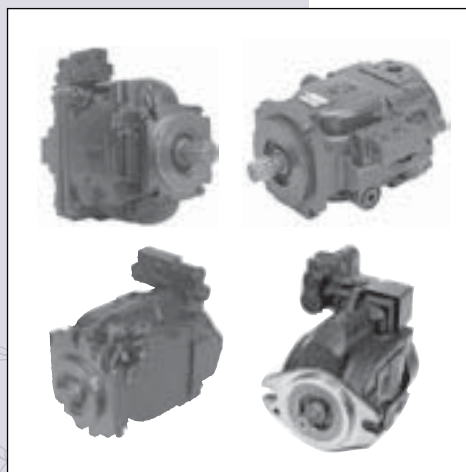
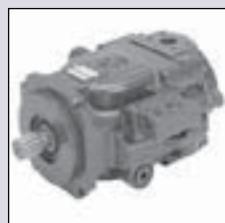
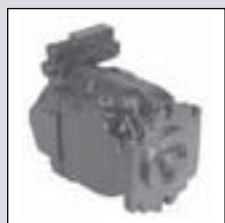

ORGANIZATION AND HEADINGS

To help you quickly find information in this manual, the material is divided into sections, topics, subtopics, and details, with descriptive headings set in *red type*. Section titles appear at the top of every page in *large red type*. Topic headings appear in the left hand column in **BOLD RED CAPITAL LETTERS**. Subtopic headings appear in the body text in **bold red type** and detail headings in *italic red type*.

References (example: See *Topic xyz*, page XX) to sections, headings, or other publications are also formatted in *red italic type*. In **P**ortable **D**ocument **F**ormat (**PDF**) files, these references represent clickable hyperlinks that jump to the corresponding document pages.

TABLES, ILLUSTRATIONS, AND COMPLEMENTARY INFORMATION

Tables, illustrations, and graphics in this manual are identified by titles set in *blue italic type* above each item. Complementary information such as notes, captions, and drawing annotations are also set in *blue type*.

References (example: See *Illustration abc*, page YY) to tables, illustrations, and graphics are also formatted in *blue italic type*. In PDF files, these references represent clickable hyperlinks that jump to the corresponding document pages.

SPECIAL TEXT FORMATTING

Defined terms and acronyms are set in **bold black type** in the text that defines or introduces them. Thereafter, the terms and acronyms receive no special formatting.

Black italic type is used in the text to emphasize important information, or to set-off words and terms used in an unconventional manner or alternative context. *Red* and *blue italics* represent hyperlinked text in the PDF version of this document (see above).

TABLE OF CONTENTS

An indented **Table of Contents (TOC)** appears on the next page. Tables and illustrations in the TOC set in *blue type*. In the PDF version of this document, the TOC entries are hyperlinked to the pages where they appear.

© 2005 Sauer-Danfoss. All rights reserved. Printed in U.S.A.

Sauer-Danfoss accepts no responsibility for possible errors in catalogs, brochures and other printed material. Sauer-Danfoss reserves the right to alter its products without prior notice. This also applies to products already ordered provided that such alterations aren't in conflict with agreed specifications. All trademarks in this material are properties of their respective owners. Sauer-Danfoss and the Sauer-Danfoss logotype are trademarks of the Sauer-Danfoss Group.

Front cover illustrations: F101 178, F101 180, F101 337, F101 168, P101 992

GENERAL INFORMATION

Overview 6

Design 6

 High performance 6

 Latest technology 6

 Reliability 6

Typical applications 6

The Series 45 product family 7

 Basic units 7

Load sensing open circuit system 8

Pressure compensated controls 9

 Operation 9

 Pressure compensated system characteristics 9

 Typical applications for pressure compensated systems 9

Remote pressure compensated controls 10

 Remote pressure compensated system characteristics 10

 Typical applications for remote pressure compensated systems 10

Load sensing controls 11

 Operation 11

 Load sensing system characteristics 11

 Typical applications for load sensing systems 11

Electrical on/off pressure compensated controls 12

Operating parameters 13

 Fluids 13

 Viscosity 13

 Temperature 13

 Inlet pressure 13

 Case pressure 13

 Pressure ratings 14

 Speed ratings 14

 Duty cycle and pump life 14

 Speed, flow, and inlet pressure 14

Design parameters 15

 Installation 15

 Filtration 15

 Reservoir 15

 Fluid velocity 16

 Shaft loads 16

 Bearing life 16

 Mounting flange loads 17

 Auxiliary mounting pads 18

 Input shaft torque ratings 18

 Understanding and minimizing system noise 19

Sizing equations 20

FRAMES L AND K

Design 21

Specifications 22

Performance L25C 23

Performance L30D 24

Performance K38C 25

Performance K45D 26

**FRAMES L AND K
 (continued)**

Order code.....	27
Controls.....	29
Pressure compensated control (PC)	29
Remote PC control (RP).....	29
Load sensing control (LS).....	30
Load sensing control with internal bleed orifice (LB)	30
Normally closed on/off electric PC control (ED)	31
Normally open on/off electric PC control (AA)	31
Input shafts.....	32
Auxiliary mounting pads	34
SAE-A auxiliary mounting pad.....	34
SAE-B auxiliary mounting pad	34
SAE - A auxiliary mounting pad at 90 degrees	35
Running cover	35
Displacement limiter.....	36
Installation drawings.....	37
Axial ported endcap	37
Radial ported endcap.....	39
Electric on/off control	41

FRAME J

Design	42
Specifications.....	43
Performance J45B	44
Performance J51B	45
Performance J60B	46
Performance J65C	47
Performance J75C	48
Order code.....	49
Controls.....	51
Pressure compensated control (PC, BC).....	51
Remote PC control (RP, BP)	51
Load sensing control (LS, BS)	52
Load sensing control with internal bleed orifice (LB, BB)	52
Normally closed on/off electric PC control (AG)	53
Normally open on/off electric PC control (AF)	53
Input shafts.....	54
Auxiliary mounting pads	57
SAE-A auxiliary mounting pad (non-integral)	57
SAE-B auxiliary mounting pad	57
Displacement limiter.....	58
SAE-C auxiliary mounting pad	58
Running cover	58
Installation drawings.....	59
Axial ported endcap	59
Radial ported endcap.....	62
Electric on/off control	64

FRAME G

Design	65
Specifications.....	66
Performance G74B.....	67
Performance G90C.....	68
Order code	69
Controls.....	71
Pressure compensated control (PC).....	71
Remote PC control (RP).....	71
Load sensing control (LS).....	72
Load sensing control with internal bleed orifice (LB)	72
Input shafts.....	73
Auxiliary mounting pads	74
SAE-A auxiliary mounting pad	74
SAE-B auxiliary mounting pad	74
Displacement limiter	75
SAE-C auxiliary mounting pad	75
Installation drawings.....	76
Running cover.....	76
Adjustable displacement limiter	76
Axial ported endcap	77
Radial ported endcap.....	79

FRAME E

Design	81
Specifications.....	82
Performance E100B	83
Performance E130B	84
Performance E147C	85
Order code	86
Controls.....	88
Pressure compensated control (PC).....	88
Remote PC control (RP).....	88
Load sensing control (LS).....	89
Load sensing control with internal bleed orifice (LB)	89
Input shafts.....	90
Auxiliary mounting pads	92
SAE-A auxiliary mounting pad	92
SAE-B auxiliary mounting pad	92
SAE-C auxiliary mounting pad	93
Running cover.....	93
Displacement limiters.....	94
Installation drawings.....	95
Axial ported endcap, clockwise rotation	95
Axial ported endcap, counterclockwise rotation	97
Radial ported endcap, clockwise rotation.....	99
Radial ported endcap, counterclockwise rotation	101

OVERVIEW

Series 45 is a complete family of variable displacement, axial piston pumps for open circuit applications. Each frame within the Series 45 family is uniquely designed to optimize performance, size, and cost, matching the work function requirements of the demanding mobile equipment marketplace.

DESIGN**High performance**

- Displacements from 25 cm³ - 147 cm³ [1.53 - 8.97 in³/rev]
- Speeds up to 3600 rpm
- Pressures up to 310 bar [4495 psi] continuous, and 400 bar [5800 psi] peak
- Variety of control system options including load sensing and pressure compensated
- Through-drive capability for multi-circuit systems
- Range of mounting flanges, shafts, and porting options for ease of installation

Latest technology

- Customer-driven using quality function deployment (QFD) and design for manufacturability (DFM) techniques
- Optimized valve plates for maximum efficiency and quiet operation
- Computer-modeled castings to optimize inlet conditions for maximum pump speed
- Compact package size minimizing installation space requirements
- Heavy-duty tapered roller bearings for long life
- Single piece rigid housing to reduce noise and leak paths
- Integrated controls for high speed response and system stability

Reliability

- Designed to rigorous standards
- Proven in both laboratory and field
- Manufactured to rigid quality standards
- Long service life
- Significantly fewer parts
- No gasketed joints
- Robust input shaft bearings to handle large external shaft loads
- Integrated gauge ports for monitoring operating conditions

TYPICAL APPLICATIONS

- Cranes
- Telescopic handlers
- Forklift trucks
- Wheel loaders
- Sweepers
- Backhoe loaders
- Forestry and agricultural machinery
- Fan drives
- Other uses

THE SERIES 45 PRODUCT FAMILY

Basic units

The series 45 family of open circuit, variable piston pumps, offers a range of displacements from 25 to 147 cm³/rev [1.53 to 8.97 in³/rev]. With maximum speeds up to 3600 rpm and continuous operating pressures up to 310 bar [4495 psi], you can tailor product selection to the flow and pressure requirements of your individual application.

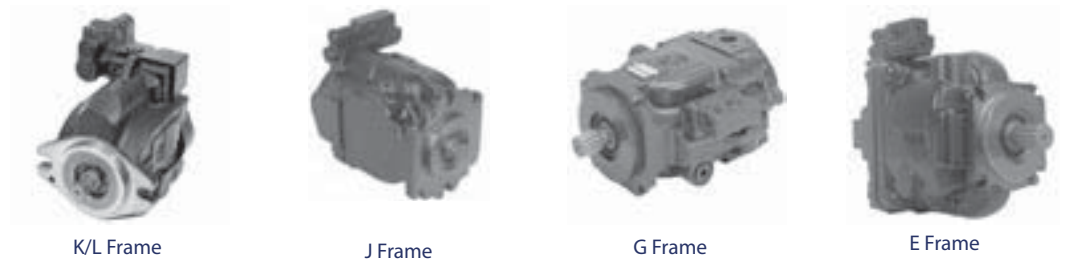

General performance specifications for the series 45 pump family

Pump	Displacement		Speed			Pressure				Theoretical flow (at rated speed)		Mounting
			Continuous	Max.	Min.	Continuous	Maximum	bar	psi	US gal/min	l/min	
Model	cm ³	in ³	min ⁻¹ (rpm)	min ⁻¹ (rpm)	min ⁻¹ (rpm)	bar	psi	bar	psi	US gal/min	l/min	Flange
Frame L												<i>See page 21</i>
L25C	25	1.53	3200	3600	500	260	3770	350	5075	21.0	80.0	SAE B - 2 bolt
L30D	30	1.83	3200	3600	500	210	3045	300	4350	25.4	96.0	SAE B - 2 bolt
Frame K												<i>See page 21</i>
K38C	38	2.32	2650	2800	500	260	3770	350	5075	26.6	100.7	SAE B - 2 bolt
K45D	45	2.75	2650	2800	500	210	3045	300	4350	31.5	119.3	SAE B - 2 bolt
Frame J												<i>See page 42</i>
J45B	45	2.75	2800	3360	500	310	4495	400	5800	33.3	126.0	SAE B 2-bolt SAE C 4-bolt
J51B	51	3.11	2700	3240	500	310	4495	400	5800	36.4	137.7	SAE B 2-bolt SAE C 4-bolt
J60B	60	3.66	2600	3120	500	310	4495	400	5800	41.2	156.0	SAE B 2-bolt SAE C 4-bolt
J65C	65	3.97	2500	3000	500	260	3770	350	5075	42.9	162.6	SAE B 2-bolt SAE C 4-bolt
J75C	75	4.58	2400	2880	500	260	3770	350	5075	47.5	180.0	SAE B 2-bolt SAE C 4-bolt
Frame G												<i>See page 65</i>
G74B	74	4.52	2400	2800	500	310	4495	400	5800	46.9	177.6	SAE B 2-bolt SAE C 4-bolt
G90C	90	5.49	2200	2600	500	260	3770	350	5075	52.3	198	SAE B 2-bolt SAE C 4-bolt
Frame E												<i>See page 81</i>
E100B	100	6.10	2450	2880	500	310	4495	400	5800	64.7	245.0	SAE C 4-bolt
E130B	130	7.93	2200	2600	500	310	4495	400	5800	75.5	286.0	SAE C 4-bolt
E147C	147	8.97	2100	2475	500	260	3770	350	5075	81.5	308.7	SAE C 4-bolt

**LOAD SENSING OPEN
 CIRCUIT SYSTEM**

The pump receives fluid directly from the reservoir through the inlet line. A screen in the inlet line protects the pump from large contaminants. The pump outlet feeds a PVG-32 multi-section, load sensing, directional control valve. The PVG valve directs pump flow to the cylinder and gear motor. A heat exchanger cools the fluid returning from the valve. A filter cleans the fluid before it returns to the reservoir.

Flow in the circuit determines the speed of the actuators. The position of the PVG valve determines the flow demand. A hydraulic pressure signal (LS signal) communicates demand to the pump control. The pump control monitors the pressure differential between pump outlet and the LS signal, and regulates servo pressure to control the swashplate angle. Swashplate angle determines pump flow.

Actuator load determines system pressure. The pump control monitors system pressure and will decrease the swashplate angle to reduce flow if system pressure reaches the PC setting. A system relief valve in the PVG valve acts as a back-up to control system pressure.

Pictorial circuit diagram

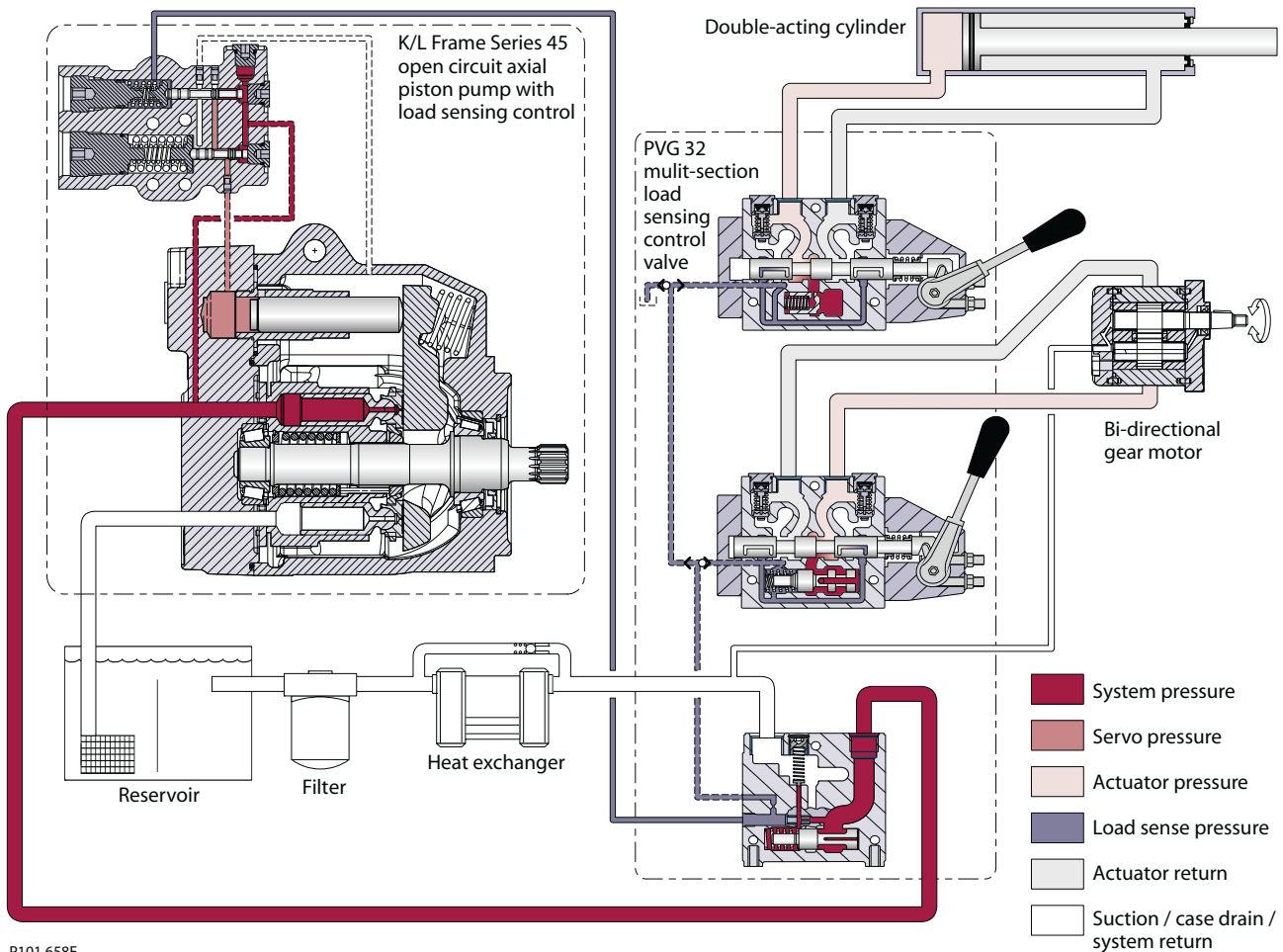

P101 658E

**PRESSURE
 COMPENSATED
 CONTROLS**

Operation

The PC control maintains constant system pressure in the hydraulic circuit by varying the output flow of the pump. Used with a closed center control valve, the pump remains in high pressure standby mode at the PC setting with zero flow until the function is actuated. This condition is often called a **dead head** condition.

Typical operating curve

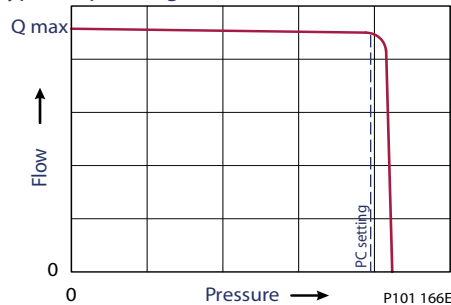

Simple closed-center circuit

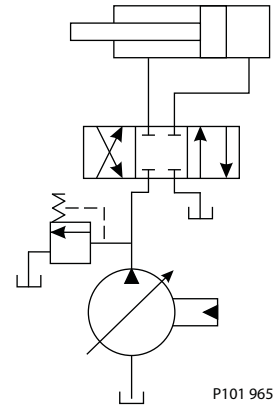

Once the closed center valve is opened, the PC control senses the immediate drop in system pressure and increases pump flow by increasing the swashplate angle. The pump continues to increase flow until system pressure reaches the PC setting. If system pressure exceeds the PC setting, the PC control reduces the swashplate angle to maintain system pressure by reducing flow. The PC control continues to monitor system pressure and changes swashplate angle to match the output flow with the work function pressure requirements.

If the demand for flow exceeds the capacity of the pump, the PC control directs the pump to maximum displacement. In this condition, actual system pressure depends on the actuator load.

For additional system protection, install a relief valve in the pump outlet line.

Each section includes control schematic diagrams, setting ranges, and response / recovery times for each control available. **Response** is the time (in milliseconds) for the pump to reach zero displacement when commanded by the control. **Recovery** is the time (in milliseconds) for the pump to reach full displacement when commanded by the control. Actual times can vary depending on application conditions.

Pressure compensated system characteristics

- Constant pressure and variable flow
- High pressure standby mode when flow is not needed
- System flow adjusts to meet system requirements
- Single pump can provide flow to multiple work functions
- Quick response to system flow and pressure requirements

Typical applications for pressure compensated systems

- Constant force cylinders (bailers, compactors, refuse trucks)
- On/off fan drives

**REMOTE PRESSURE
 COMPENSATED
 CONTROLS**

The remote PC control is a two-stage control that allows multiple PC settings. Remote PC controls are commonly used in applications requiring low and high pressure PC operation.

Typical operating curve

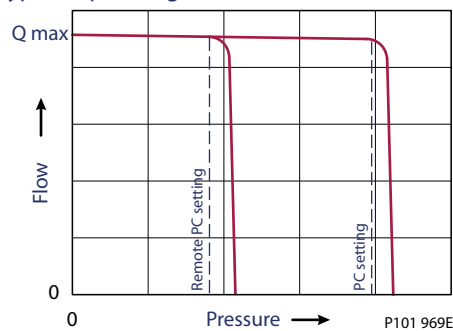

Closed center circuit with remote PC

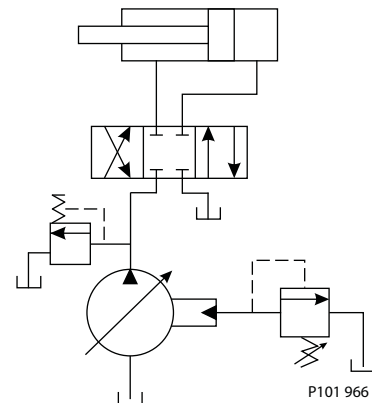

The remote PC control uses a pilot line connected to an external hydraulic valve. The external valve changes pressure in the pilot line, causing the PC control to operate at a lower pressure. When the pilot line is vented to reservoir, the pump maintains a low standby pressure of 15 to 20 bar [215 to 300 psi]. When pilot flow is blocked, the pump maintains pressure at the PC setting. An on-off solenoid valve can be used in the pilot line to create a low-pressure standby mode. A proportional solenoid valve, coupled with a microprocessor control, can produce an infinite range of operating pressures.

Each section includes control schematic diagrams, setting ranges, and response / recovery times for each control available. **Response** is the time (in milliseconds) for the pump to reach zero displacement when commanded by the control. **Recovery** is the time (in milliseconds) for the pump to reach full displacement when commanded by the control. Actual times can vary depending on application conditions.

Size the external valve and plumbing for a pilot flow of 3.8 l/min [1 US gal/min]. For additional system protection, install a relief valve in the pump outlet line.

Remote pressure compensated system characteristics

- Constant pressure and variable flow
- High or low pressure standby mode when flow is not needed
- System flow adjusts to meet system requirements
- Single pump can provide flow to multiple work functions
- Quick response to system flow and pressure requirements

Typical applications for remote pressure compensated systems

- Modulating fan drives
- Anti-stall control with engine speed feedback
- Front wheel assist

**LOAD SENSING
 CONTROLS**

Operation

The LS control matches system requirements for both pressure and flow in the circuit regardless of the working pressure. Used with a closed center control valve, the pump remains in low-pressure standby mode with zero flow until the valve is opened. The LS setting determines standby pressure.

Typical operating curve

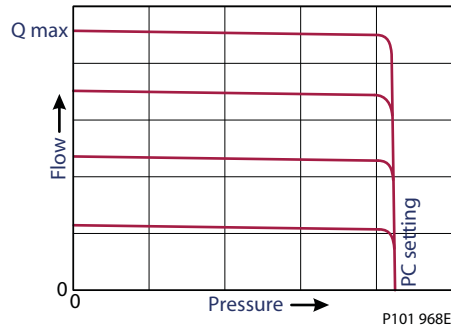

Load sensing circuit

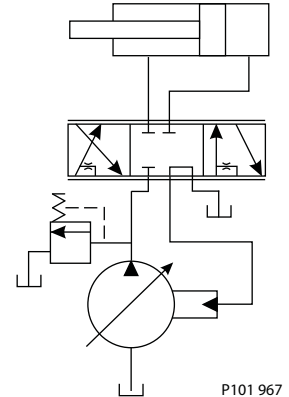

Most load sensing systems use parallel, closed center, control valves with special porting that allows the highest work function pressure (LS signal) to feed back to the LS control. **Margin pressure** is the difference between system pressure and the LS signal pressure. The LS control monitors margin pressure to read system demand. A drop in margin pressure means the system needs more flow. A rise in margin pressure tells the LS control to decrease flow.

LS control with bleed orifice

The load sense signal line requires a bleed orifice to prevent high-pressure lockup of the pump control. Most load-sensing control valves include this orifice. An optional internal bleed orifice is available, if needed.

Integral PC function

The LS control also performs as a PC control, decreasing pump flow when system pressure reaches the PC setting. The pressure compensating function has priority over the load sensing function.

For additional system protection, install a relief valve in the pump outlet line.

Each section includes control schematic diagrams, setting ranges, and response / recovery times for each control available. **Response** is the time (in milliseconds) for the pump to reach zero displacement when commanded by the control. **Recovery** is the time (in milliseconds) for the pump to reach full displacement when commanded by the control. Actual times can vary depending on application conditions.

Load sensing system characteristics

- Variable pressure and flow
- Low pressure standby mode when flow is not needed
- System flow adjusted to meet system requirements
- Single pump can supply flow and regulate pressure for multiple circuits
- Quick response to system flow and pressure requirements

Typical applications for load sensing systems

- Priority steering
- Load independent flow control for boom lift, tilt, and rotation

**ELECTRICAL ON/
 OFF PRESSURE
 COMPENSATED
 CONTROLS**

The electrical on/off pressure compensated control allows the pump to operate as a PC type control under normal operating conditions. A solenoid valve overrides the PC control allowing the pump to operate in a low-pressure standby mode. This function provides reduced horsepower and torque loss in certain situations. It may be particularly useful to reduce loads on a system during engine start.

ED schematic (normally closed)

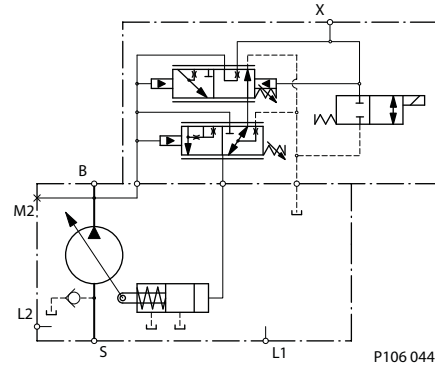

When closed, the solenoid valve prevents flow across the LS spool gain orifice, defeating the LS spool. The pump then functions as a PC control pump. When open, the solenoid valve allows flow across the LS spool gain orifice to reservoir. This flow generates a pressure differential across the LS spool that shifts the spool and de-strokes the pump. The pump then operates in a low-pressure standby condition. The solenoid valve is available in a normally closed or normally open configuration.

ED is the nomenclature for a normally closed on/off control for the L and K frame pumps. Other frame sizes and configurations have different order code designations.

(ED) Electric control cross-section

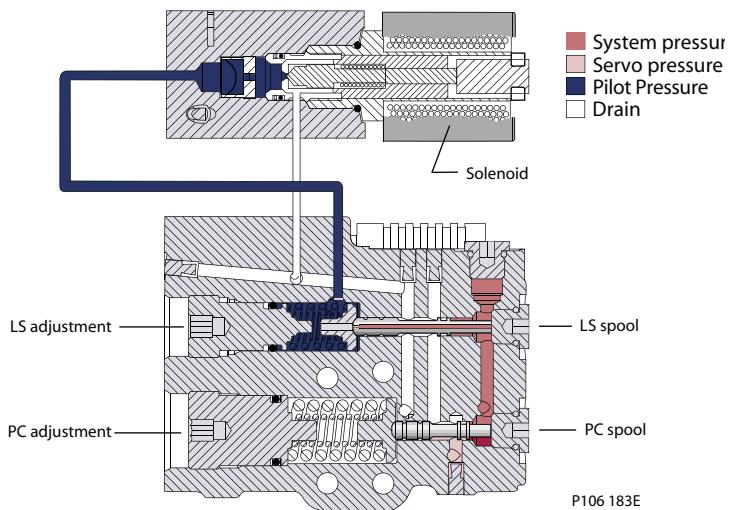

**OPERATING
 PARAMETERS**

Fluids

Ratings and performance data for Series 45 products are based on operating with premium hydraulic fluids containing oxidation, rust, and foam inhibitors. These include premium turbine oils, API CD engine oils per SAE J183, M2C33F or G automatic transmission fluids (ATF), Dexron II (ATF) meeting Allison C-3 or Caterpillar T0-2 requirements, and certain specialty agricultural tractor fluids. For more information on hydraulic fluid selection, see Sauer-Danfoss publications **520L0463 *Hydraulic Fluids and Lubricants, Technical Information***, and **520L465 *Experience with Biodegradable Hydraulic Fluids, Technical Information***.

Viscosity

Maintain fluid viscosity within the recommended range for maximum efficiency and bearing life. **Minimum viscosity** should only occur during brief occasions of maximum ambient temperature and severe duty cycle operation. **Maximum viscosity** should only occur at cold start: Limit speeds until the system warms up.

Fluid viscosity limits

Condition		mm ² /s (cSt)	SUS
v min.	continuous	9	58
	intermittent	6.4	47
v max.	continuous	110	500
	intermittent (cold start)	1000	4700

Temperature

Maintain fluid temperature within the limits shown in the table. **Minimum temperature** relates to the physical properties of the component materials. Cold oil will not affect the durability of the pump components. However, it may affect the ability of the pump to provide flow and transmit power. **Maximum temperature** is based on material properties. Don't exceed it. Measure maximum temperature at the hottest point in the system. This is usually the case drain.

Temperature limits

Minimum (intermittent, cold start)	- 40° C [- 40° F]
Continuous	82° C [180° F]
Maximum	104° C [220° F]

Ensure fluid temperature and viscosity limits are concurrently satisfied.

Inlet pressure

Maintain inlet pressure within the limits shown in the table. Low inlet pressure (vacuum) may limit maximum pump speed and cause cavitation. Refer to *Inlet pressure vs. speed* charts for each displacement.

Inlet pressure limits

Minimum (continuous)	0.8 bar absolute [6.7 in. Hg vac.] (at reduced maximum speed)
Minimum (cold start)	0.5 bar absolute [15.1 in. Hg vac.]

Case pressure

Maintain case pressure within the limits shown in the table. The housing must always be filled with hydraulic fluid.

Case pressure limits

Maximum (continuous)	0.5 bar [7 psi] above inlet
Intermittent (cold start)	2 bar [29 psi] above inlet

⚠ Caution

Operating outside of inlet and case pressure limits will damage the pump. To minimize this risk, use full size inlet and case drain plumbing, and limit line lengths.

**OPERATING
 PARAMETERS
 (continued)**

Pressure ratings

The specification tables in each section give maximum and continuous pressure ratings for each displacement. Not all displacements within a given frame operate under the same pressure limits. Definitions of the operating pressure limits appear below.

System pressure is the differential pressure between the outlet and inlet ports. It is the dominant operating variable affecting hydraulic unit life. High system pressure, which results from high load, reduces expected life. System pressure must remain at or below rated pressure during normal operation to achieve expected life.

Continuous working pressure is the average, regularly occurring operating pressure. Operating at or below this pressure should yield satisfactory product life. For all applications, the load should move below this pressure.

Maximum (peak) working pressure is the highest intermittent pressure allowed. Maximum machine load should never exceed this pressure.

Speed ratings

The specification tables in each section give minimum, maximum, and rated speeds for each displacement. Not all displacements within a given frame operate under the same speed limits. Definitions of these speed limits appear below.

Rated speed is the maximum recommended operating speed at full displacement and 1 bar abs. [0 in Hg vac] inlet pressure. Operating at or below this speed should yield satisfactory product life.

Maximum speed is the highest recommended operating speed at full power conditions. Operating at or beyond maximum speed requires positive inlet pressure and/or a reduction of pump outlet flow. Refer to *Inlet pressure vs. speed* charts for each displacement.

Minimum speed is the lowest operating speed allowed. Operating below this speed will not yield satisfactory performance.

Duty cycle and pump life

Knowing the operating conditions of your application is the best way to ensure proper pump selection. With accurate duty cycle information, your Sauer-Danfoss representative can assist in calculating expected pump life.

Speed, flow, and inlet pressure

Inlet pressure vs. speed charts in each section show the relationship between speed, flow, and inlet pressure for each displacement. Use these charts to ensure your application operates within the prescribed range.

The charts define the area of inlet pressures and speeds allowed for a given displacement. Operating at lower displacements allows greater speed or lower inlet pressure.

Sample inlet pressure vs. speed chart

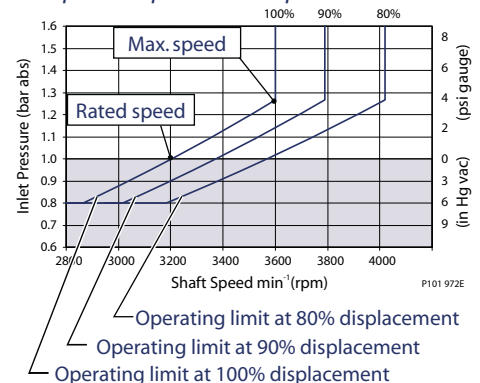

DESIGN PARAMETERS

Installation

Series 45 pumps may be installed in any position. To optimize inlet conditions, we recommend installing the pump at an elevation below the minimum reservoir fluid level. Design inlet plumbing to maintain inlet pressure within prescribed limits (see *Inlet pressure limits*, page 13)

Fill the pump housing and inlet line with clean fluid during installation. Connect the case drain line to the uppermost drain port (L1 or L2) to keep the housing full during operation.

To allow unrestricted flow to the reservoir, use a dedicated drain line. Connect it below the minimum reservoir fluid level and as far away from the reservoir outlet as possible. Use plumbing adequate to maintain case pressure within prescribed limits (see *Case pressure limits*, page 13).

Filtration

To prevent damage to the pump, including premature wear, fluid entering the pump inlet must be free of contaminants. Series 45 pumps require system filtration capable of maintaining fluid cleanliness at ISO 4406-1999 class 22/18/13 or better.

Sauer-Danfoss does not recommend suction line filtration. Suction line filtration can cause high inlet vacuum, which limits pump operating speed. Instead we recommend a 125 μm (150 mesh) screen in the reservoir covering the pump inlet. This protects the pump from coarse particle ingestion.

Return line filtration is the preferred method for open circuit systems. Consider these factors when selecting a system filter:

- Cleanliness specifications
- Contaminant ingress rates
- Flow capacity
- Desired maintenance interval

Typically, a filter with a beta ratio of $\beta_{10} = 10$ is adequate. However, because each system is unique, only a thorough testing and evaluation program can fully validate the filtration system. For more information, see Sauer-Danfoss publication **520L0467** *Design Guidelines for Hydraulic Fluid Cleanliness*.

Reservoir

The reservoir provides clean fluid, dissipates heat, and removes entrained air from the hydraulic fluid. It allows for fluid volume changes associated with fluid expansion and cylinder differential volumes. Minimum reservoir capacity depends on the volume needed to perform these functions. Typically, a capacity of one to three times the pump flow (per minute) is satisfactory.

Locate the reservoir outlet (suction line) near the bottom, allowing clearance for settling foreign particles. Place the reservoir inlet (return lines) below the lowest expected fluid level, as far away from the outlet as possible.

DESIGN PARAMETERS
 (continued)

Fluid velocity

Choose piping sizes and configurations sufficient to maintain optimum fluid velocity, and minimize pressure drops. This reduces noise, pressure drops, and overheating. It maximizes system life and performance.

Recommended fluid velocities

System lines	6 to 9 m/sec [20 to 30 ft/sec]
Suction line	1 to 2 m/sec [4 to 6 ft/sec]
Case drain	3 to 5 m/sec [10 to 15 ft/sec]

Typical guidelines; obey all pressure ratings.

Velocity equations SI units

Q = flow (l/min)
 A = area (mm²)

$$\text{Velocity} = \frac{16.67 \cdot Q}{A} \quad (\text{m/sec})$$

US units

Q = flow (US gal/min)
 A = area (in²)

$$\text{Velocity} = \frac{0.321 \cdot Q}{A} \quad (\text{ft/sec})$$

Shaft loads

Series 45 pumps have tapered roller bearings capable of accepting external radial and thrust loads. The external radial shaft load limits are a function of the load position, orientation, and the operating conditions of the pump.

The maximum allowable radial load (R_e) is based on the maximum external moment (M_e) and the distance (L) from the mounting flange to the load. Compute radial loads using the formula below. Tables in each section give maximum external moment (M_e) and thrust load (T_{in}, T_{out}) limits for each pump frame size and displacement.

Radial load formula

$$M_e = R_e \cdot L$$

- L = Distance from mounting flange to point of load
- M_e = Maximum external moment
- R_e = Maximum radial side load

Shaft load orientation

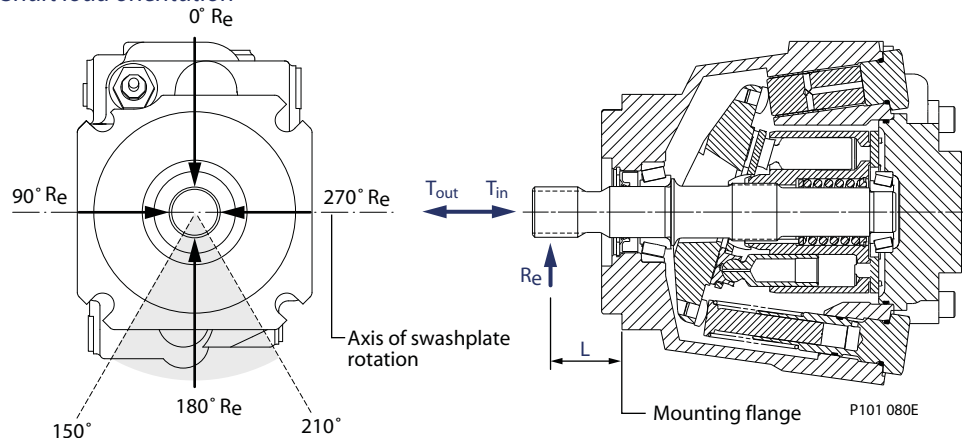

Bearing life

All shaft loads affect bearing life. In applications where external shaft loads can not be avoided, maximize bearing life by orientating the load between the 150° and 210° positions, as shown. We recommend tapered input shafts or clamp-type couplings for applications with radial shaft loads. Tables in each section give B_{10} bearing life for each pump frame size and displacement.

DESIGN PARAMETERS
 (continued)

Mounting flange loads

Adding auxiliary pumps and/or subjecting pumps to high shock loads may overload the pump mounting flange. Tables in each section give allowable continuous and shock load moments for each frame size. Applications with loads outside allowable limits require additional pump support.

- **Shock load moment** (M_s) is the result of an instantaneous jolt to the system.
- **Continuous load moments** (M_c) are generated by the typical vibratory movement of the application.

Estimating overhung load moments

Use the equations below to estimate the overhung load moments for multiple pump mounting. See installation drawings in each section to find the distance from the mounting flange to the center of gravity for each frame size. Refer to the technical specifications in each section to find pump weight.

Overhung load example

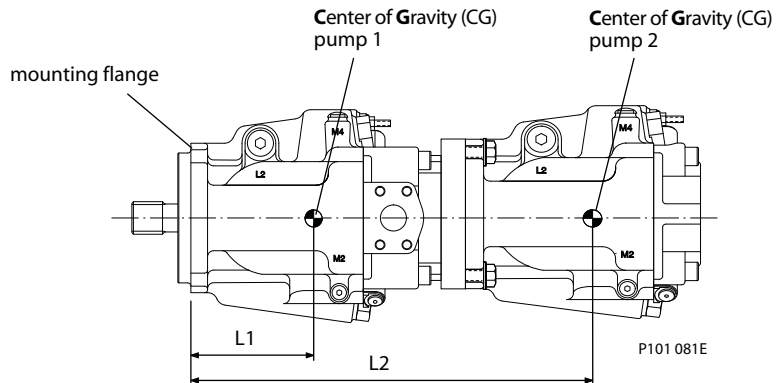

Shock load formula $M_s = G_s \cdot K \cdot (W_1 \cdot L_1 + W_2 \cdot L_2 + \dots + W_n \cdot L_n)$

Continuous load formula $M_c = G_c \cdot K \cdot (W_1 \cdot L_1 + W_2 \cdot L_2 + \dots + W_n \cdot L_n)$

SI units

- M_s = Shock load moment (N•m)
- M_c = Continuous (vibratory) load moment (N•m)
- G_s = Acceleration due to external shock (G's)
- G_c = Acceleration due to continuous vibration (G's)
- K = Conversion factor = 0.00981
- W_n = Mass of n^{th} pump (kg)
- L_n = Distance from mounting flange to n^{th} pump CG (mm)

US units

- M_s = Shock load moment (lbf•in)
- M_c = Continuous (vibratory) load moment (lbf•in)
- G_s = Acceleration due to external shock (G's)
- G_c = Acceleration due to continuous vibration (G's)
- K = Conversion factor = 1
- W_n = Weight of n^{th} pump (lb)
- L_n = Distance from mounting flange to n^{th} pump CG (in)

DESIGN PARAMETERS
 (continued)

Auxiliary mounting pads

Auxiliary mounting pads are available for all radial ported Series 45 pumps. Since the auxiliary pad operates under case pressure, use an O-ring to seal the auxiliary pump mounting flange to the pad. Oil from the main pump case lubricates the drive coupling.

- All mounting pads meet SAE J744 Specifications.
- The combination of auxiliary shaft torque and main pump torque must not exceed the maximum pump input shaft rating. Tables in each section give input shaft torque ratings for each frame size.
- Applications subject to severe vibratory or shock loading may require additional support to prevent mounting flange damage. Tables in each section give allowable continuous and shock load moments for each frame size.
- The drawing and table below give mating pump dimensions for each size mount. Refer to installation drawings in each section for auxiliary mounting pad dimensions.

Mating pump specifications

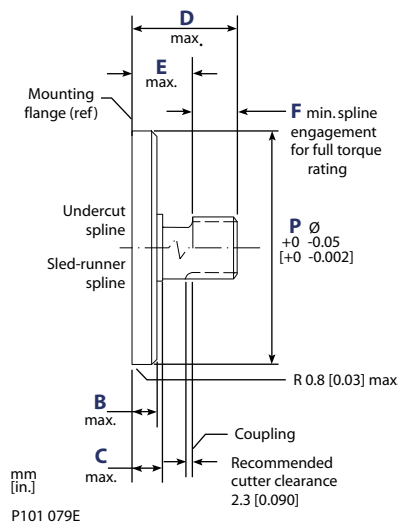

Dimensions

	SAE A	SAE B	SAE C
P	82.55 [3.250]	101.60 [4.000]	127.00 [5.000]
B	6.35 [0.250]	9.65 [0.380]	12.70 [0.500]
C	12.70 [0.500]	15.20 [0.600]	23.37 [0.920]
D	58.20 [2.290]	53.10 [2.090]	55.60 [2.190]
E	15.00 [0.590]	17.50 [0.690]	30.50 [1.200]
F	13.50 [0.530]	14.20 [0.560]	18.30 [0.720]

Input shaft torque ratings

Input shaft tables in each section give maximum torque ratings for available input shafts. Ensure that your application respects these limits.

Maximum torque ratings are based on shaft strength. Do not exceed them.

Coupling arrangements that are not oil-flooded provide a reduced torque rating. Contact your Sauer-Danfoss representative for proper torque ratings if your application involves non oil-flooded couplings.

Sauer-Danfoss recommends mating splines adhere to ANSI B92.1-Class 5. Sauer-Danfoss external splines are modified class 5 fillet root side fit. The external major diameter and circular tooth thickness dimensions are reduced to ensure a good clearance fit with the mating spline. Tables in each section give full spline dimensions and data.

DESIGN PARAMETERS
(continued)

Understanding and minimizing system noise

Tables in each section give sound levels for each frame size and displacement. Sound level data are collected at various operating speeds and pressures in a semi-anechoic chamber. Many factors contribute to the overall noise level of any application. Here is some information to help understand the nature of noise in fluid power systems, and some suggestions to help minimize it.

Noise is transmitted in fluid power systems in two ways: as fluid borne noise, and structure borne noise.

Fluid-borne noise (pressure ripple or pulsation) is created as pumping elements discharge oil into the pump outlet. It is affected by the compressibility of the oil, and the pump's ability to transition pumping elements from high to low pressure. Pulsations travel through the hydraulic lines at the speed of sound (about 1400 m/s [4600 ft/sec] in oil) until there is a change (such as an elbow) in the line. Thus, amplitude varies with overall line length and position.

Structure-borne noise is transmitted wherever the pump casing connects to the rest of the system. The way system components respond to excitation depends on their size, form, material, and mounting.

System lines and pump mounting can amplify pump noise. Follow these suggestions to help minimize noise in your application:

- Use flexible hoses.
- Limit system line length.
- If possible, optimize system line position to minimize noise.
- If you must use steel plumbing, clamp the lines.
- If you add additional support, use rubber mounts.
- Test for resonants in the operating range, if possible avoid them.

SIZING EQUATIONS

Use these equations to help choose the right pump size and displacement for your application:

Based on SI units

Flow Output flow $Q = \frac{V_g \cdot n \cdot \eta_v}{1000}$ (l/min)

Torque Input torque $M = \frac{V_g \cdot \Delta p}{20 \cdot \pi \cdot \eta_m}$ (N·m)

Power Input power $P = \frac{M \cdot n \cdot \pi}{30\,000} = \frac{Q \cdot \Delta p}{600 \cdot \eta_t}$ (kW)

Based on US units

Output flow $Q = \frac{V_g \cdot n \cdot \eta_v}{231}$ (US gal/min)

Input torque $M = \frac{V_g \cdot \Delta p}{2 \cdot \pi \cdot \eta_m}$ (lbf·in)

Input power $P = \frac{M \cdot n \cdot \pi}{198\,000} = \frac{Q \cdot \Delta p}{1714 \cdot \eta_t}$ (hp)

Variables SI units [US units]

V_g	= Displacement per revolution	cm ³ /rev [in ³ /rev]
p_o	= Outlet pressure	bar [psi]
p_i	= Inlet pressure	bar [psi]
Δp	= $p_o - p_i$ (system pressure)	bar [psi]
n	= Speed	min ⁻¹ (rpm)
η_v	= Volumetric efficiency	
η_m	= Mechanical efficiency	
η_t	= Overall efficiency ($\eta_v \cdot \eta_m$)	

DESIGN

Series 45 Frame L and K pumps have a single servo piston design with a cradle-type swashplate set in polymer-coated journal bearings. A bias spring and internal forces increase swashplate angle. The servo piston decreases swashplate angle. Nine reciprocating pistons displace fluid from the pump inlet to the pump outlet as the cylinder block rotates on the pump input shaft. The block spring holds the piston slippers to the swashplate via the slipper retainer. The cylinder block rides on a bi-metal valve plate optimized for high volumetric efficiency and low noise. Tapered roller bearings support the input shaft and a viton lip-seal protects against shaft leaks.

An adjustable one spool (PC only, not shown) or two spool (LS and remote PC) control senses system pressure and load pressure (LS controls). The control ports system pressure to the servo piston to control pump output flow.

Frame K/L cross section

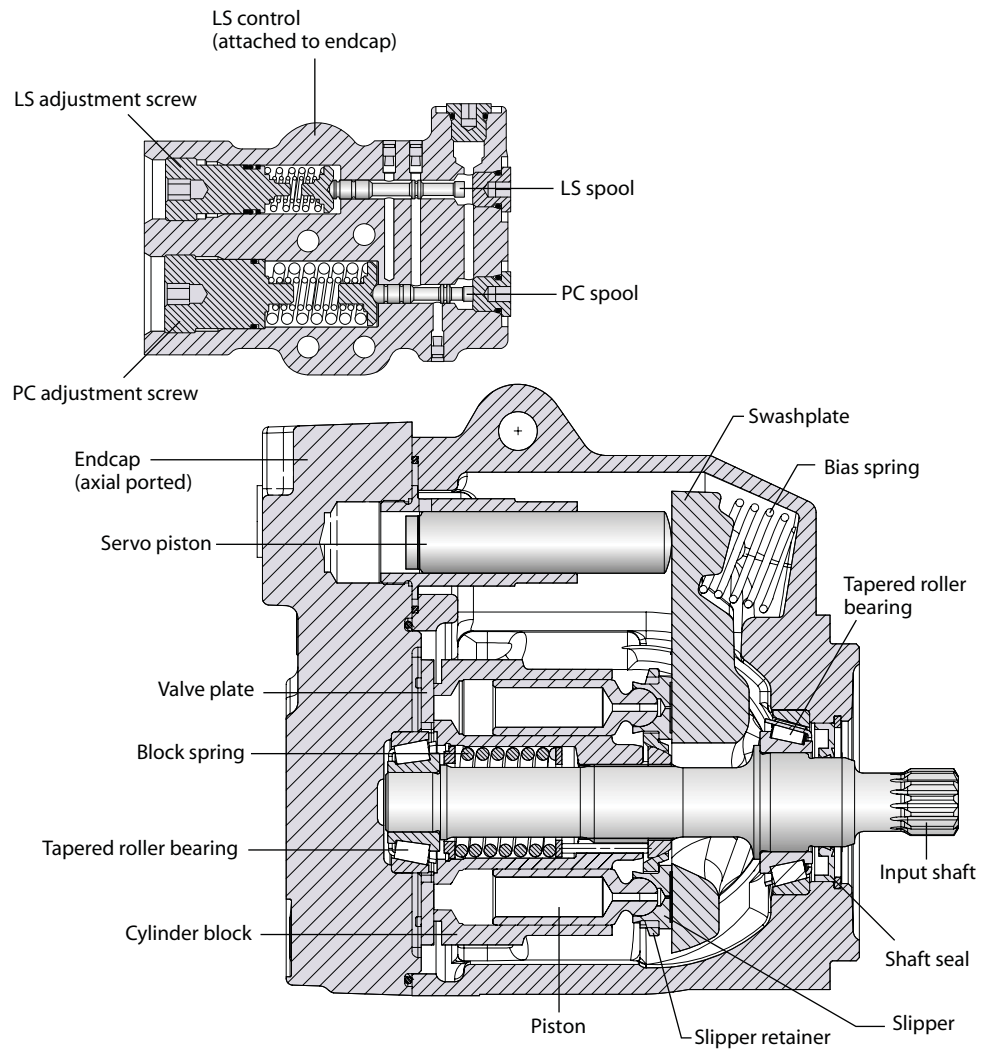

P101 659E

SPECIFICATIONS

For general operating parameters, including fluid viscosity, temperature, and inlet and case pressures, [see page 13](#). For system design parameters, including installation, filtration, reservoir, and line velocities, [see page 15](#).

Features and options		Model			
		L25C	L30D	K38C	K45D
Maximum Displacement	cm ³ [in ³]	25 [1.53]	30 [1.83]	38 [2.32]	45 [2.75]
Flow at rated speed (theoretical)	l/min [US gal/min]	80 [21]	96 [25.4]	100.7 [26.6]	119.3 [31.5]
Input torque at maximum displacement (theoretical)	N•m/bar [lbf•in/1000 psi]	0.398 [243]	0.477 [291]	0.605 [369]	0.716 [438]
Mass moment of inertia of internal rotating components	kg•m ² [slug•ft ²]	0.00169 [0.00125]	0.00161 [0.00119]	0.00184 [0.00135]	0.00203 [0.00150]
Weight	Axial ports	19 [42]			
	Radial ports	24 [53]			
Rotation		Clockwise, Counterclockwise			
Mounting		SAE-B			
Auxiliary mounting (See page 34)		SAE-A, SAE-B, SAE-BB			
System ports (type)		SAE O-ring boss			
System ports (location)		Axial, Radial			
Control types (See page 29)		ED, AA, PC, Remote PC, LS, LS with internal bleed			
Shafts (See page 32)	Splined	13 tooth, 15 tooth			
	Tapered	Ø 25.4 mm [1 in], 1:8 taper Ø 22.23 mm [0.875 in], 1:8 taper			
	Straight	Ø 22.23 mm [0.875 in] (short)		Ø 22.23 mm [0.875 in] (long)	
Displacement limiters (See page 36)		Optional, adjustable			

For definitions of pressure and speed ratings, [see page 14](#). For more information on external shaft loads, [see page 16](#); mounting flange loads, [see page 17](#).

Ratings			Model			
			L25C	L30D	K38C	K45D
Input speed ¹	minimum	min ⁻¹ (rpm)	500	500	500	500
	continuous		3200	3200	2650	2650
	maximum		3600	3600	2800	2800
Working pressure	continuous	bar [psi]	260 [3770]	210 [3045]	260 [3770]	210 [3045]
	maximum		350 [5075]	300 [4350]	350 [5075]	300 [4350]
External shaft loads	External moment (M _e)	N•m [lbf•in]	61 [540]	61 [540]	76 [673]	76 [673]
	Thrust in (T _m), out (T _{out})	N [lbf]	1000 [225]	1000 [225]	1200 [270]	1200 [270]
Bearing life	at 140 bar [2030 psi]	B ₁₀ hours	49 100	24 600	35 300	19 600
	at 210 bar [3045 psi]		14 100	7230	11 400	6200
	at 260 bar [3770 psi]		6590	—	5870	—
Mounting flange load moments	Vibratory (continuous)	N•m [lbf•in]	1005 [8895]			
	Shock (max)		3550 [31 420]			

1. Input speeds are valid at 1 bar absolute [0 in Hg vac] inlet pressure. See [Inlet pressure vs. speed](#) charts.

Sound levels²

For more information on noise levels, [see page 19](#).

dB(A)	210 bar [3045 psi]		260 bar [3770 psi]	
	1800 min ⁻¹ (rpm)	Rated speed	1800 min ⁻¹ (rpm)	Rated speed
L25C	65	69	66	70
L30D	66	70	—	—
K38C	65	70	66	71
K45D	66	71	—	—

2. Sound data was collected in a *semi-anechoic* chamber. Values have been adjusted (-3 dB) to reflect *anechoic* levels.

PERFORMANCE
L25C

Flow and power data valid at 49°C [120°F] and viscosity of 17.8 mm²/sec [88 SUS].

Flow vs. speed

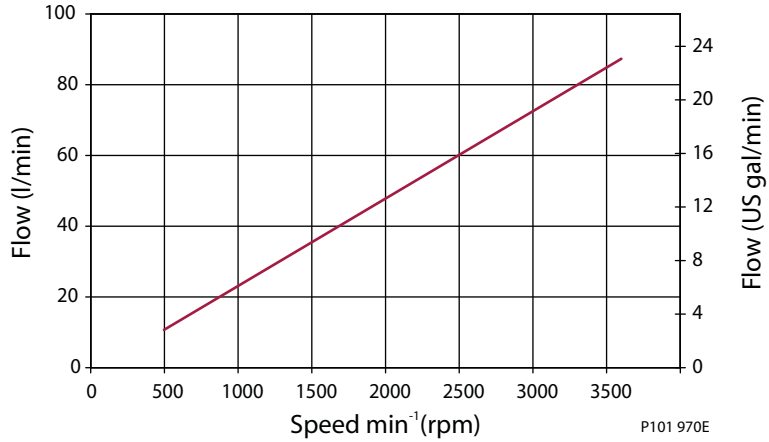

Input power vs. speed

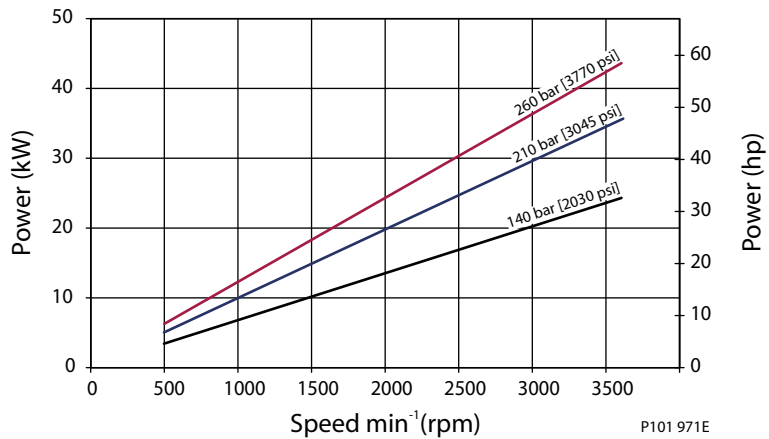

Inlet pressure vs. speed

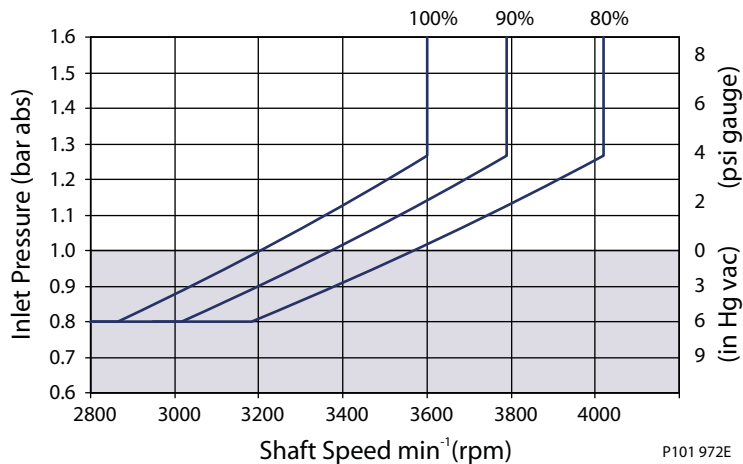

The chart on the right shows allowable inlet pressure and speed at various displacements. Greater speeds and lower inlet pressures are possible at reduced displacement. Operating outside of acceptable limits reduces pump life.

PERFORMANCE
L30D

Flow and power data valid at 49°C [120°F] and viscosity of 17.8 mm²/sec [88 SUS].

Flow vs. speed

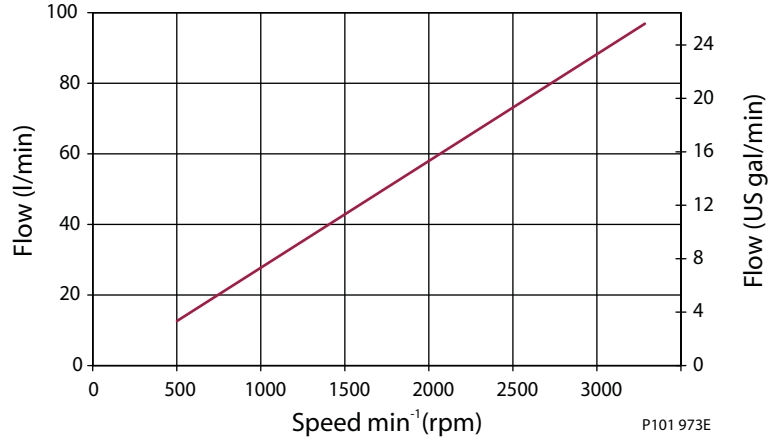

Input power vs. speed

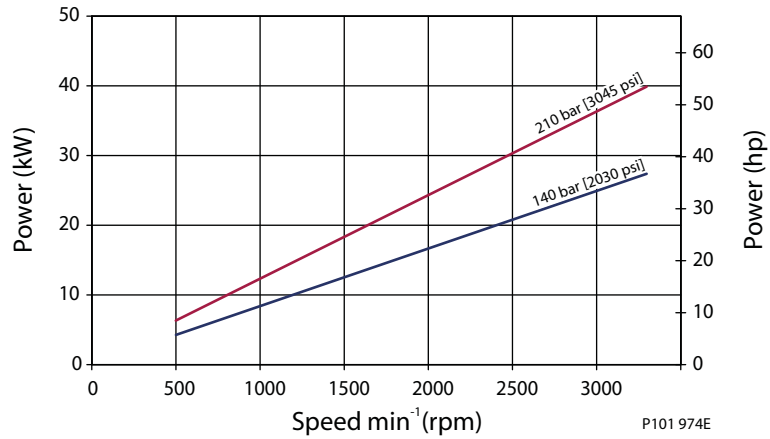

Inlet pressure vs. speed

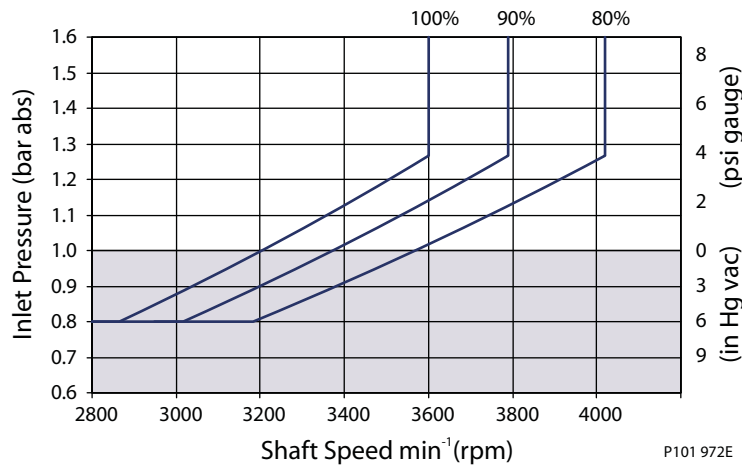

The chart on the right shows allowable inlet pressure and speed at various displacements. Greater speeds and lower inlet pressures are possible at reduced displacement. Operating outside of acceptable limits reduces pump life.

PERFORMANCE
K38C

Flow and power data valid at 49°C [120°F] and viscosity of 17.8 mm²/sec [88 SUS].

Flow vs. speed

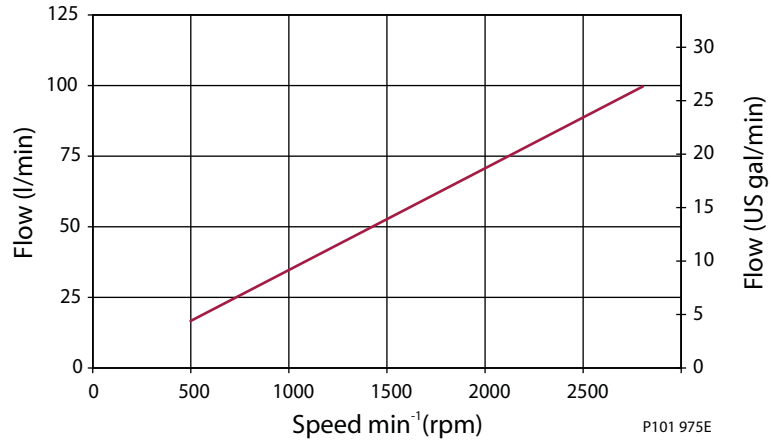

Input power vs. speed

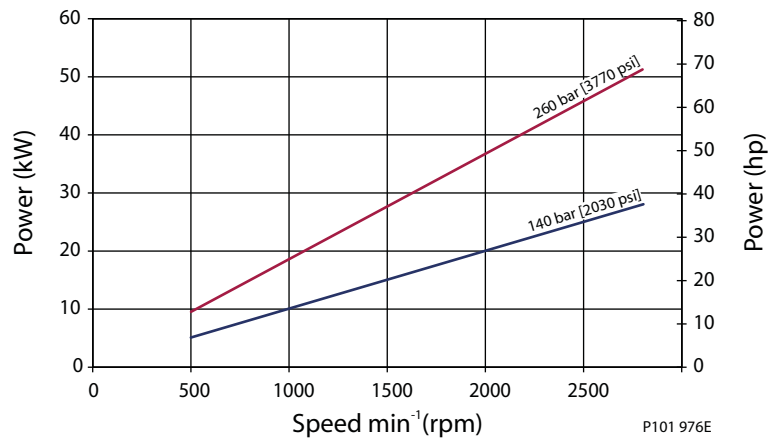

Inlet pressure vs. speed

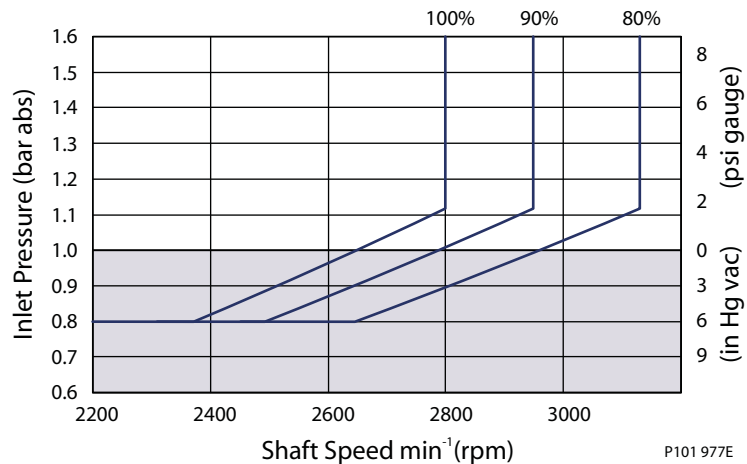

The chart on the right shows allowable inlet pressure and speed at various displacements. Greater speeds and lower inlet pressures are possible at reduced displacement. Operating outside of acceptable limits reduces pump life.

PERFORMANCE
K45D

Flow and power data valid at 49°C [120°F] and viscosity of 17.8 mm²/sec [88 SUS].

Flow vs. speed

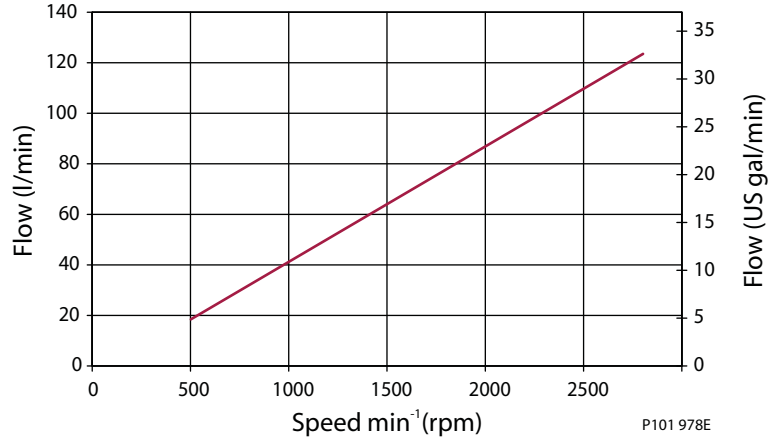

Input power vs. speed

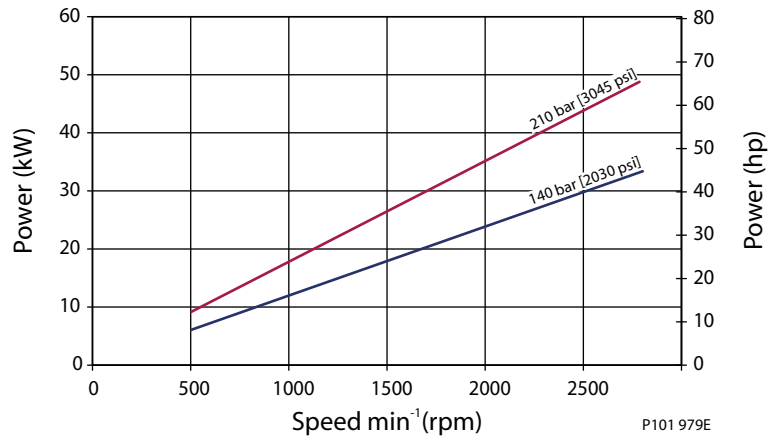

Inlet pressure vs. speed

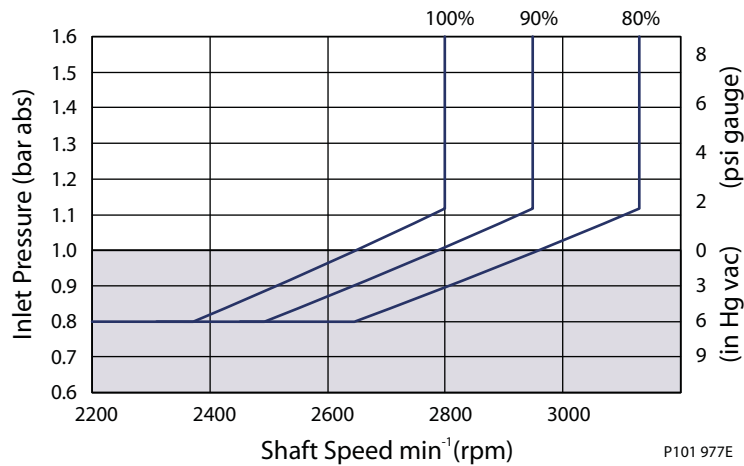

The chart on the right shows allowable inlet pressure and speed at various displacements. Greater speeds and lower inlet pressures are possible at reduced displacement. Operating outside of acceptable limits reduces pump life.

ORDER CODE



R Product

KR	K Frame, variable displacement open circuit pump
LR	L Frame, variable displacement open circuit pump

S Rotation

L	Left hand (counterclockwise)
R	Right hand (clockwise)

P Displacement and pressure rating

025C	025 cm ³ /rev [1.53 in ³ /rev], 260 bar [3770 psi] continuous working pressure
030D	030 cm ³ /rev [1.83 in ³ /rev], 210 bar [3045 psi] continuous working pressure
038C	038 cm ³ /rev [2.32 in ³ /rev], 260 bar [3770 psi] continuous working pressure
045D	045 cm ³ /rev [2.75 in ³ /rev], 210 bar [3045 psi] continuous working pressure

C Control type

PC	Pressure compensated control
RP	Remote pressure compensated control
LS	Load sensing / pressure compensating control
LB	Load sensing / pressure compensating control with internal bleed orifice
ED	Normally closed on/off electric PC control
AA	Normally open on/off electric PC control

D PC setting (2 digit code, 10 bar increments)

Example	10 = 100
10-26	100 to 260 bar [1450 to 3770 psi] (025C and 038C)
10-21	100 to 210 bar [1450 to 3045 psi] (030D and 045D)

E Load sensing setting (2 digit code, 1 bar increments)

Example	20 = 20 bar
12-40	12 to 40 bar [174 to 580 psi]
NN	Not applicable (use with PC and RP controls)

F Not used

NN	Not applicable
-----------	----------------

G Pilot orifice

N	None (standard)
----------	-----------------

H Gain orifice

3	Standard orifice
----------	------------------

ORDER CODE
 (continued)



J1 *Input shaft*

C2	13 tooth, 16/32 pitch (ANSI A92.1 1970 - Class 5)
C3	15 tooth, 16/32 pitch (ANSI A92.1 1970 - Class 5)
T1	Ø 25.4 mm [1 in], 1:8 taper
T2	Ø 22.23 mm [0.875 in], 1:8 taper
K1	Ø 22.23 mm [0.875 in] (short)
K2	Ø 22.23 mm [0.875 in] (long)

J2 *Auxiliary mounting flange*

N	None
A	SAE-A, 9-tooth output spline
T	SAE-A, 11-tooth output spline
B	SAE-B, 13-tooth output spline
V	SAE-BB, 15-tooth output spline

J3 *System port size and location*

Code	Location	Port type	Inlet size	Outlet size
2	Radial	4 bolt split flange	31.8 mm [1.25 in]	25.4 mm [1 in]
4	Axial	4 bolt split flange	31.8 mm [1.25 in]	25.4 mm [1 in]
F	Axial	O-ring boss	1 7/8 in.	1 5/16 in.
G	Radial	O-ring boss	1 7/8 in.	1 5/16 in.

K1 *Shaft seal*

A	Single lip seal, viton
----------	------------------------

K2 *Mounting flange and housing port style*

6	SAE-B 2-bolt, SAE O-ring boss housing ports
----------	---

K3 *Not used*

N	Not applicable
----------	----------------

L *Displacement limiter*

KNB	None
PLB	Endcap machined and plugged
AAA	Adjustable, factory set at max angle

M *Special hardware*

NNN	None
------------	------

N *Special features*

NNN	None
------------	------

CONTROLS

Pressure compensated control (PC)

Specifications **PC control setting range**

Model	bar	psi
L25C	100–260	1450–3770
L30D	100–210	1450–3045
K38C	100–260	1450–3770
K45D	100–210	1450–3045

*Response/recovery times**

(ms)	Response	Recovery
L25C	30	90
L30D	30	100
K38C	30	105
K45D	30	110

* For definitions, see page 9

Schematic diagram **PC schematic**

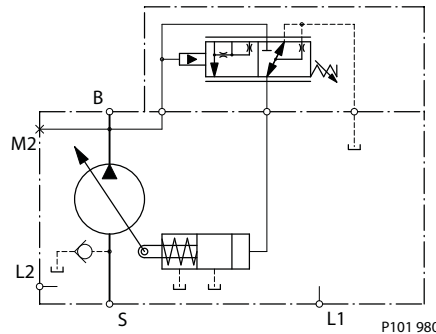

Legend

- B = Outlet
- S = Inlet
- L1, L2 = Case drain
- M2 = System pressure gauge port

Remote PC control (RP)

Specifications **PC control setting range**

Model	bar	psi
L25C	100–260	1450–3770
L30D	100–210	1450–3045
K38C	100–260	1450–3770
K45D	100–210	1450–3045

*Response/recovery times**

(ms)	Response	Recovery
L25C	30	90
L30D	30	100
K38C	30	105
K45D	30	110

* For definitions, see page 10.

Schematic diagram **Remote PC schematic**

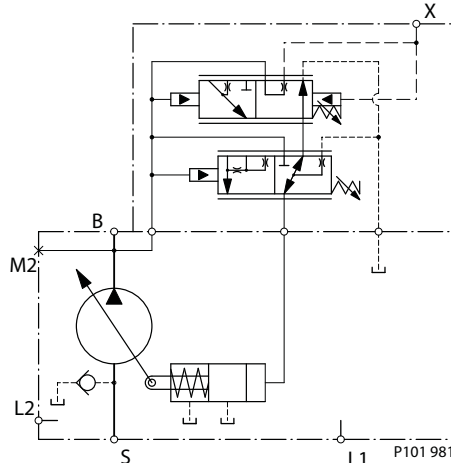

Legend

- B = Outlet
- S = Inlet
- L1, L2 = Case drain
- M2 = System pressure gauge port
- X = Remote PC port

CONTROLS
 (continued)

Load sensing control (LS)

Specifications *PC setting range*

Model	bar	psi
L25C	100–260	1450–3770
L30D	100–210	1450–3045
K38C	100–260	1450–3770
K45D	100–210	1450–3045

*Response/recovery times**

(ms)	Response	Recovery
L25C	30	70
L30D	30	70
K38C	30	80
K45D	30	80

Schematic diagram *LS Schematic*

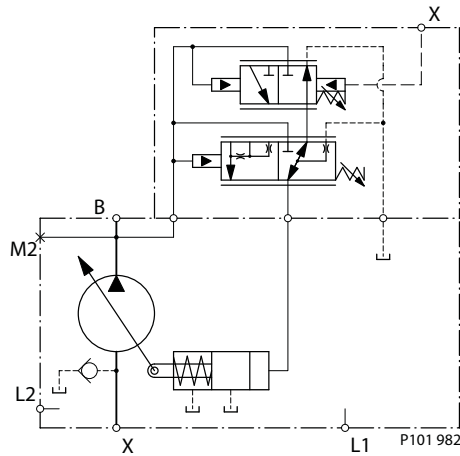

* For definitions, see page 11.

LS setting range

Model	bar	psi
All	12–40	174–580

Legend

- B = Outlet
- S = Inlet
- L1, L2 = Case drain
- M2 = System pressure gauge port
- X = LS signal port

Load sensing control with internal bleed orifice (LB)

Specifications *PC setting range*

Model	bar	psi
L25C	100–260	1450–3770
L30D	100–210	1450–3045
K38C	100–260	1450–3770
K45D	100–210	1450–3045

*Response/recovery times**

(ms)	Response	Recovery
L25C	30	70
L30D	30	70
K38C	30	80
K45D	30	80

Schematic diagram *LB Schematic*

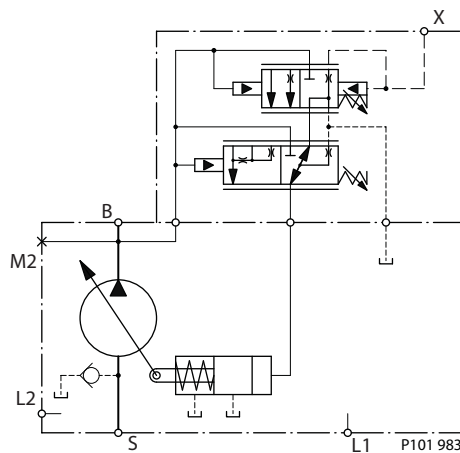

* For definitions, see page 11.

LS setting range

Model	bar	psi
All	12–40	174–580

Legend

- B = Outlet
- S = Inlet
- L1, L2 = Case drain
- M2 = System pressure gauge port
- X = LS signal port

CONTROLS
 (continued)

Normally closed on/off electric PC control (ED)

Specifications *PC control setting range*

Model	bar	psi
L25C, K38C	100-240 bar	[1450-3480 psi]
L30D, K45D	100-210 bar	[1450-3045 psi]

*Response/recovery times**

(ms)	Response	Recovery
L25C	30	90
L30D	30	100
K38C	30	105
K45D	30	110

* For definitions, see page 12.

Schematic diagram *ED schematic*

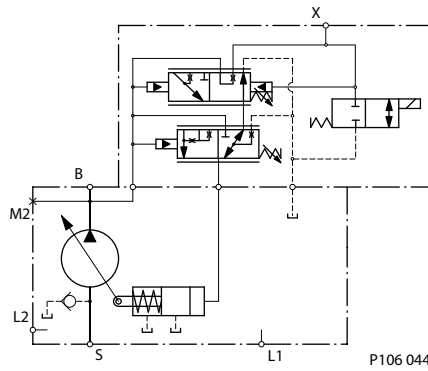

Legend

- B = Outlet
- S = Inlet
- L1, L2 = Case drain
- M2 = System pressure gauge port
- X = Remote PC port

Normally open on/off electric PC control (AA)

Specifications *PC control setting range*

Model	bar	psi
L25C, K38C, L30D, K45D	100-210 bar	[1450-3045 psi]
L30D, K45D	100-210 bar	[1450-3045 psi]

*Response/recovery times**

(ms)	Response	Recovery
L25C	30	90
L30D	30	100
K38C	30	105
K45D	30	110

* For definitions, see page 12.

Schematic diagram *AA schematic*

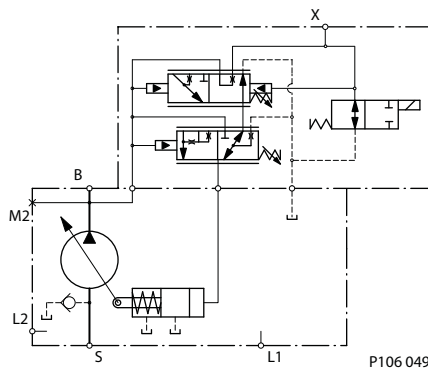

Legend

- B = Outlet
- S = Inlet
- L1, L2 = Case drain
- M2 = System pressure gauge port
- X = Remote PC port

The system must be evaluated to decide if normally open on/off (failsafe) control is necessary.

INPUT SHAFTS

Code	Description	Maximum torque rating ¹ N·m [lbf·in]	Drawing
C2	13 tooth spline 16/32 pitch (ANSI A92.1 1970 - Class 5)	288 [2546]	
C3	15 tooth spline 16/32 pitch (ANSI A92.1 1970 - Class 5)	404 [3575]	
T1	Ø 25.4 mm [1 in] 1:8 taper (SAE J501)	362 [3200]	

1. See *Input shaft torque ratings*, page 18 for an explanation of maximum torque.

INPUT SHAFTS
 (continued)

Code	Description	Maximum torque rating ¹ N•m [lbf•in]	Drawing
T2	Ø 22.23 mm [0.875 in] 1:8 taper (SAE J501)	305 [2700]	
K1	Ø 22.23 mm [0.875 in] 33 mm [1.3 in] long	305 [2700]	
K2	Ø 22.23 mm [0.875 in] 63 mm [2.48 in] long	305 [2700]	

1. See *Input shaft torque ratings*, page 18 for an explanation of maximum torque.

AUXILIARY MOUNTING PADS

See page 18 for mating pump pilot and spline dimensions.

SAE-A auxiliary mounting pad
 Dimensions

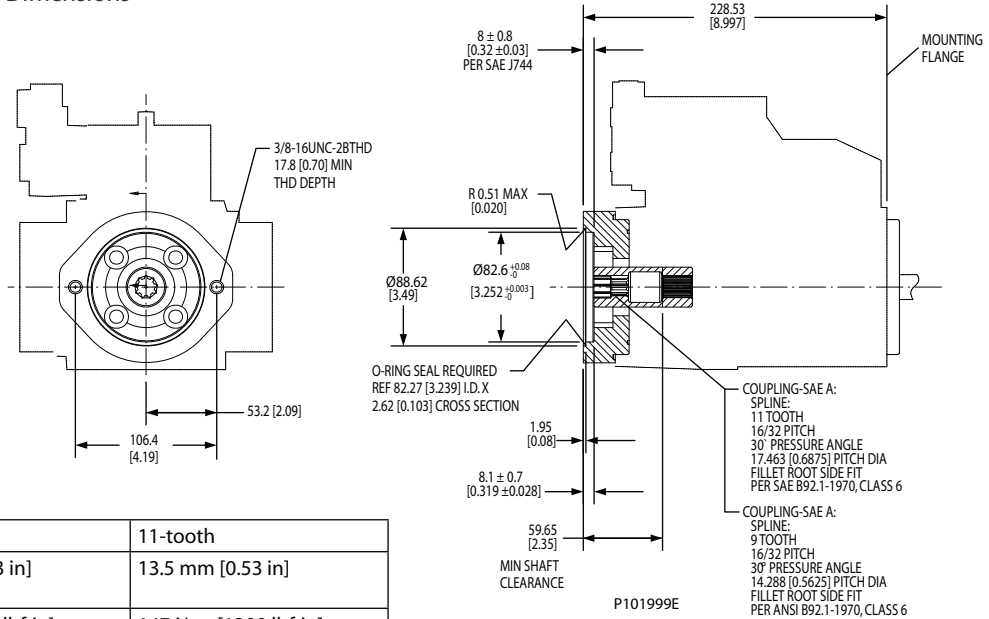

Specifications

Coupling	9-tooth	11-tooth
Spline minimum engagement	13.5 mm [0.53 in]	13.5 mm [0.53 in]
Maximum torque	107 N•m [950 lbf•in]	147 N•m [1300 lbf•in]

SAE-B auxiliary mounting pad
 Dimensions

See page 18 for mating pump pilot and spline dimensions.

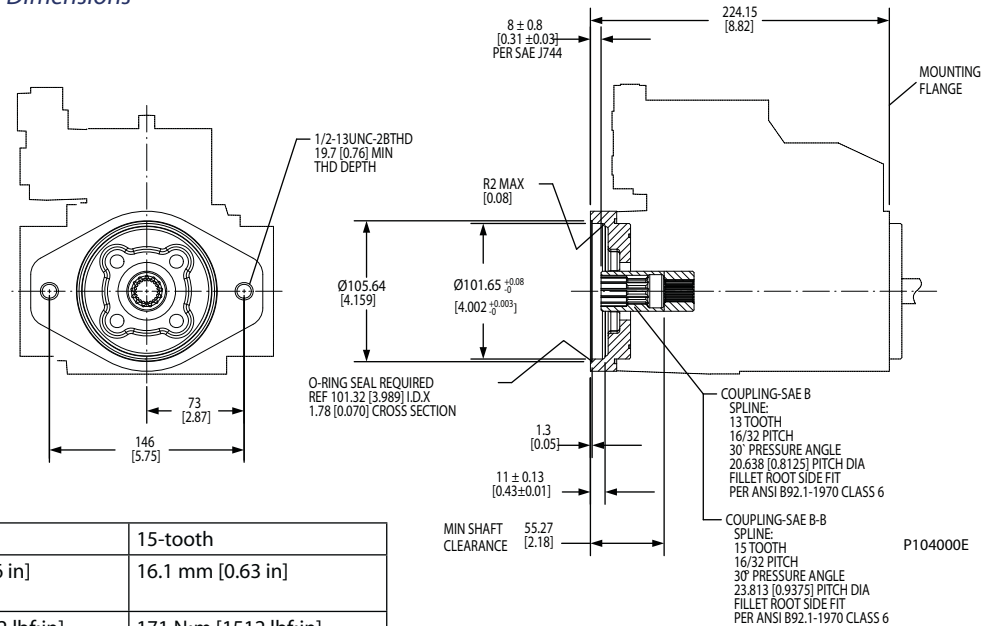

Specifications

Coupling	13-tooth	15-tooth
Spline minimum engagement	14.2 mm [0.56 in]	16.1 mm [0.63 in]
Maximum torque	171 N•m [1512 lbf•in]	171 N•m [1512 lbf•in]

**AUXILLIARY MOUNTING
PADS (continued)**

SAE - A auxiliary mounting pad at 90 degrees

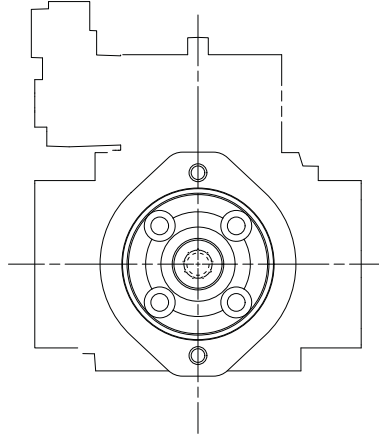

P106 076E

Running cover
Dimensions

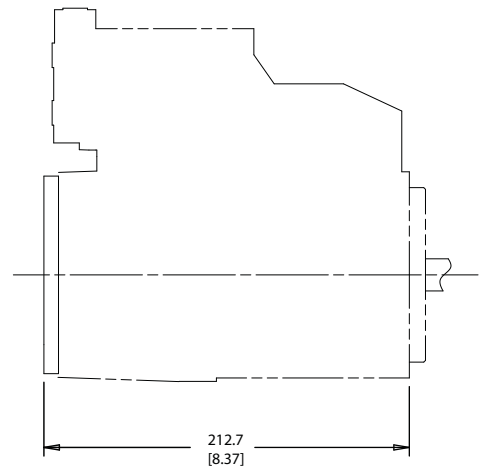
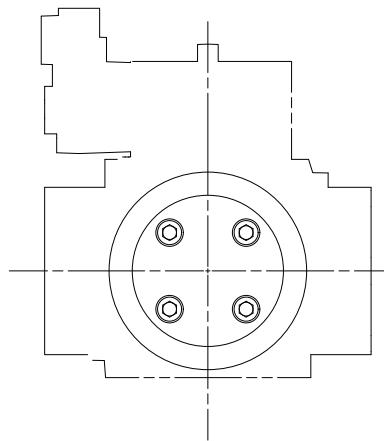

P106 077E

DISPLACEMENT LIMITER

L and K Frame open circuit pumps are available with an optional adjustable displacement limiter. This adjustable stop limits the pump's maximum displacement.

Displacement limiter cross-section

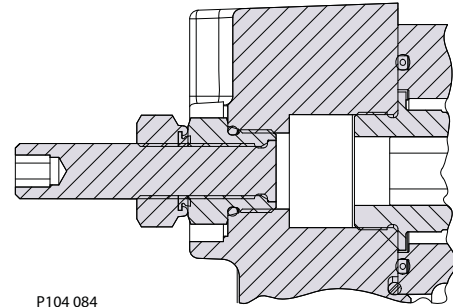

Setting range

L25C	0 to 25 cm ³ [0 to 1.53 in ³]
L30D	0 to 30 cm ³ [0 to 1.83 in ³]
K38C	0 to 38 cm ³ [0 to 2.32 in ³]
K45D	0 to 45 cm ³ [0 to 2.75 in ³]

**INSTALLATION
 DRAWINGS**

Axial ported endcap

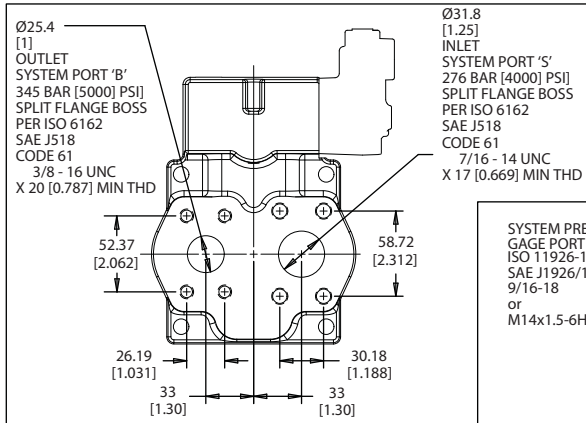

Split flange axial ports - counterclockwise rotation

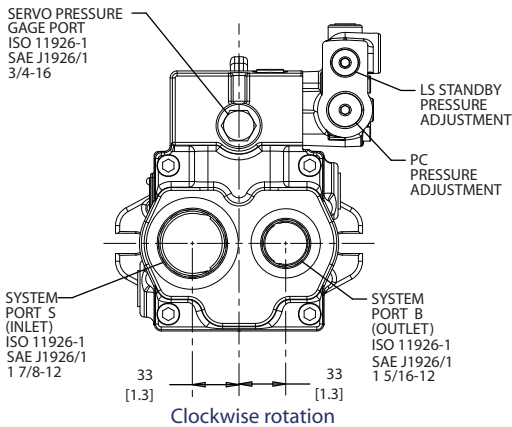

Clockwise rotation

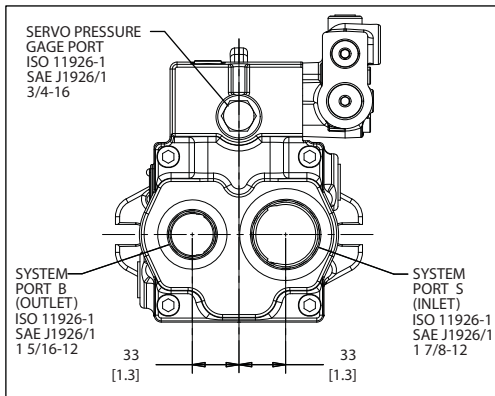

Counterclockwise rotation

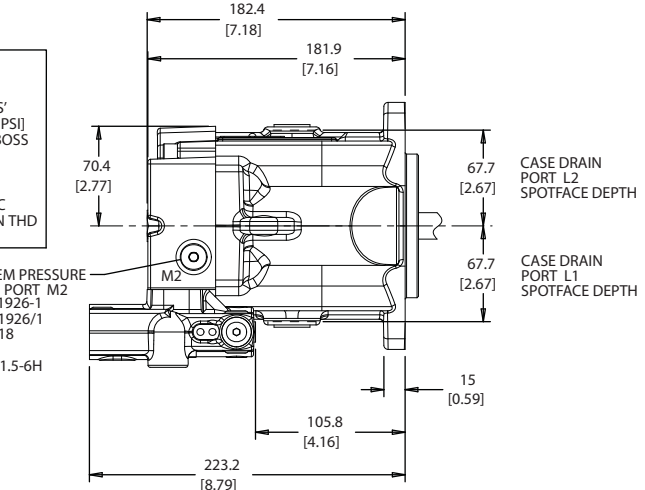

CASE DRAIN PORT L2 SPOTFACE DEPTH

CASE DRAIN PORT L1 SPOTFACE DEPTH

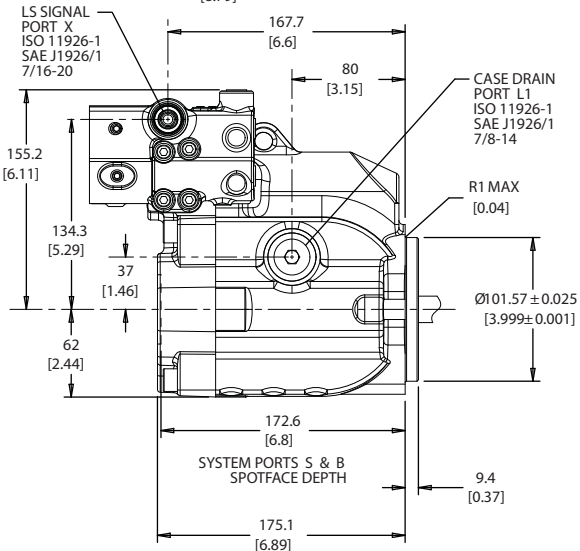

P106170E

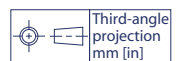

**INSTALLATION
 DRAWINGS
 (continued)**

Axial ported endcap (continued)

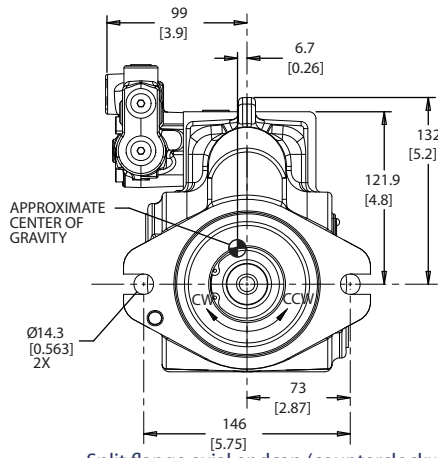

Split flange axial endcap (counterclockwise rotation shown)

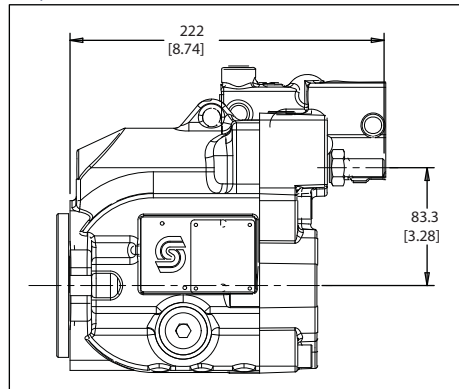
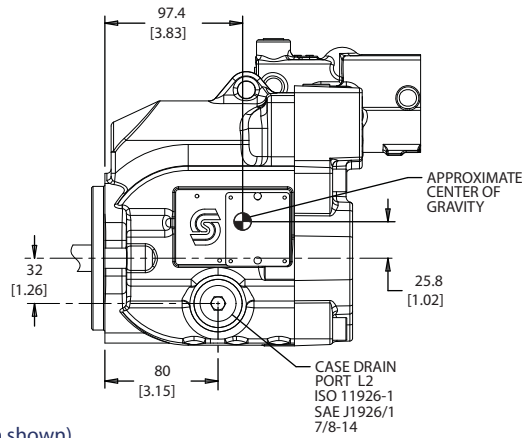

Adjustable displacement limiter

P104064E

**INSTALLATION
 DRAWINGS
 (continued)**

Radial ported endcap

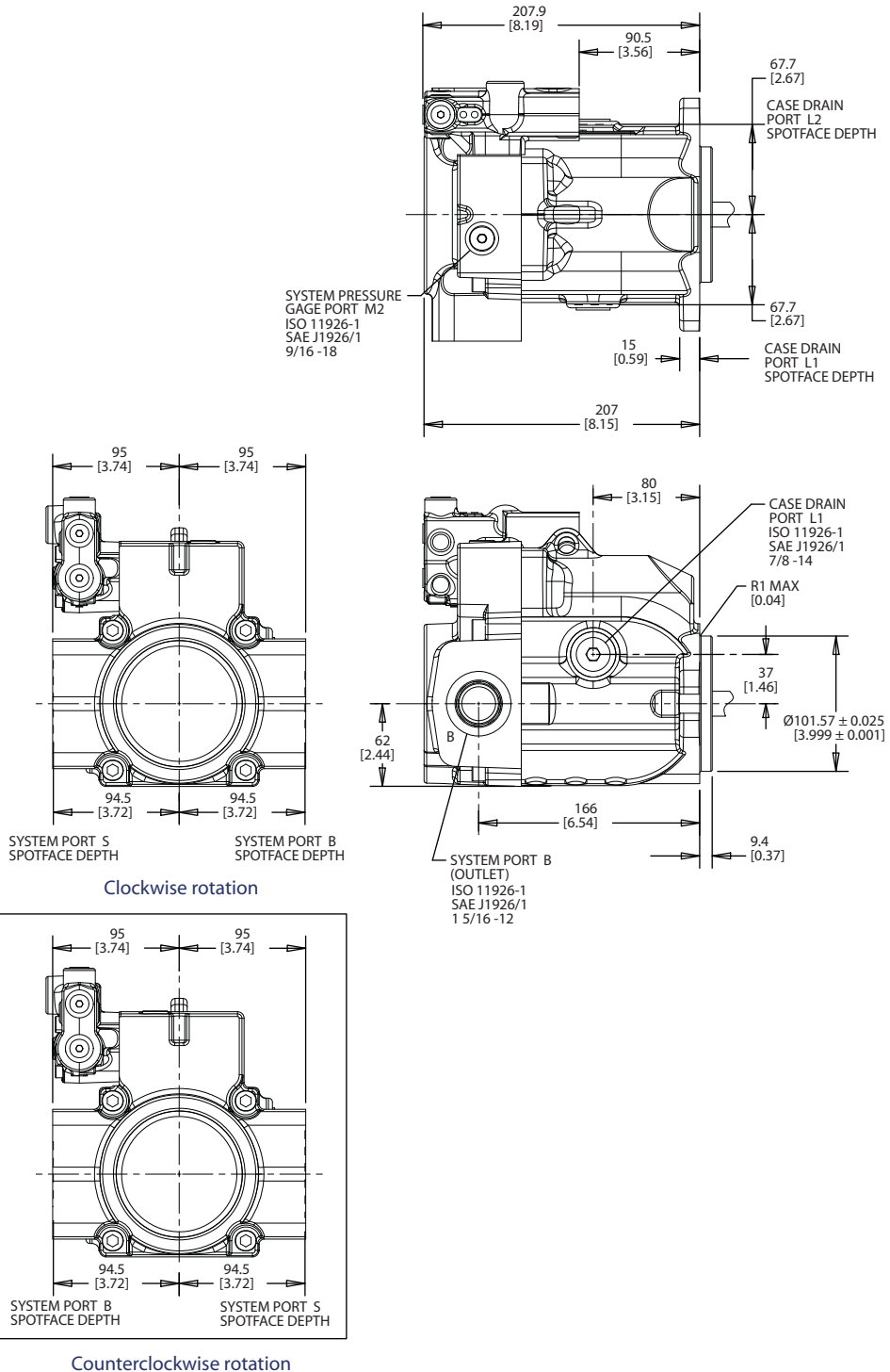

P106 171E

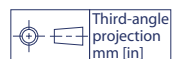

**INSTALLATION
DRAWINGS
(continued)**

Radial ported endcap (continued)

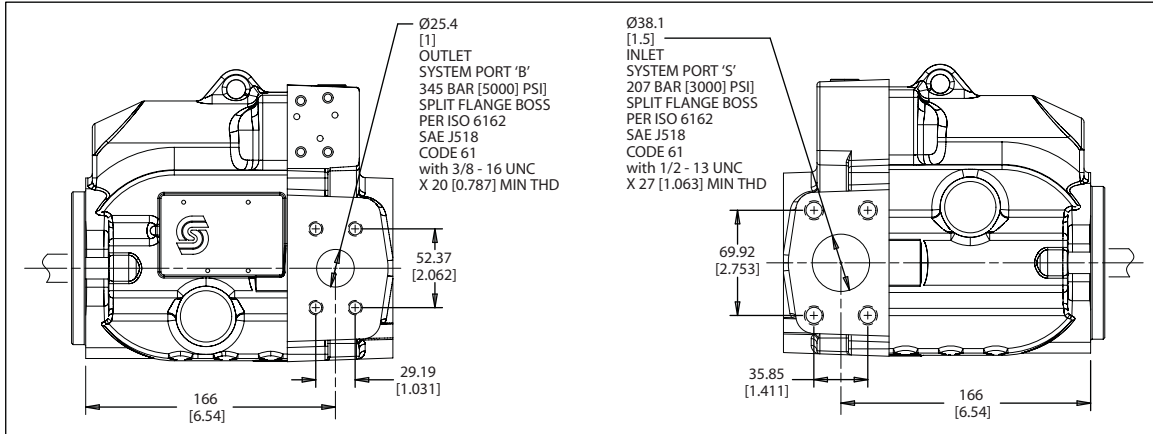

Split flange radial endcap (counterclockwise rotation shown)

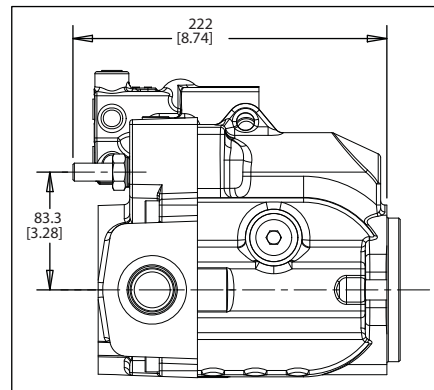
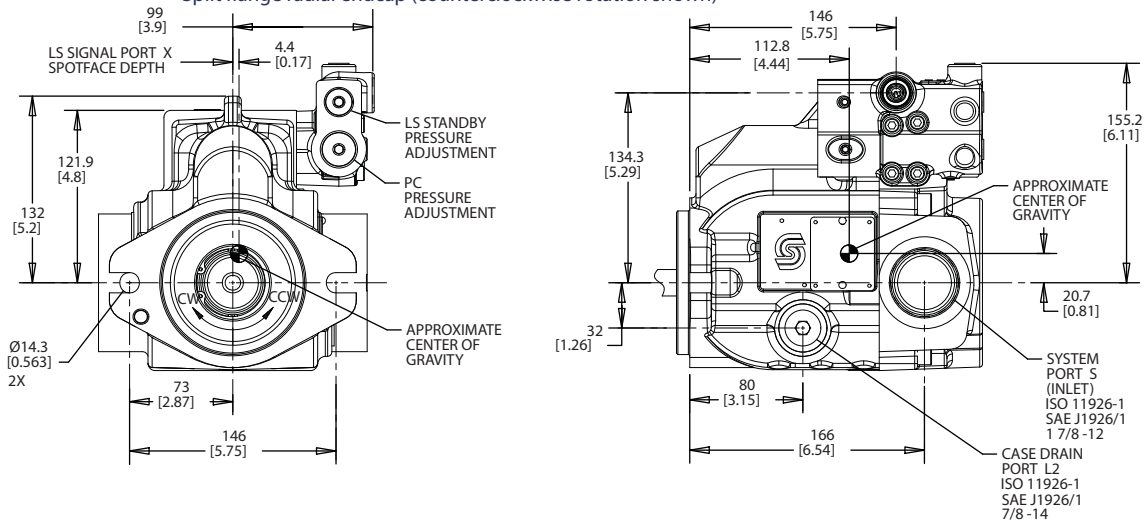

P104 065E

Adjustable displacement limiter



**INSTALLATION
DRAWINGS
(continued)**

Electric on/off control

Electric solenoid
control assembly (right side)

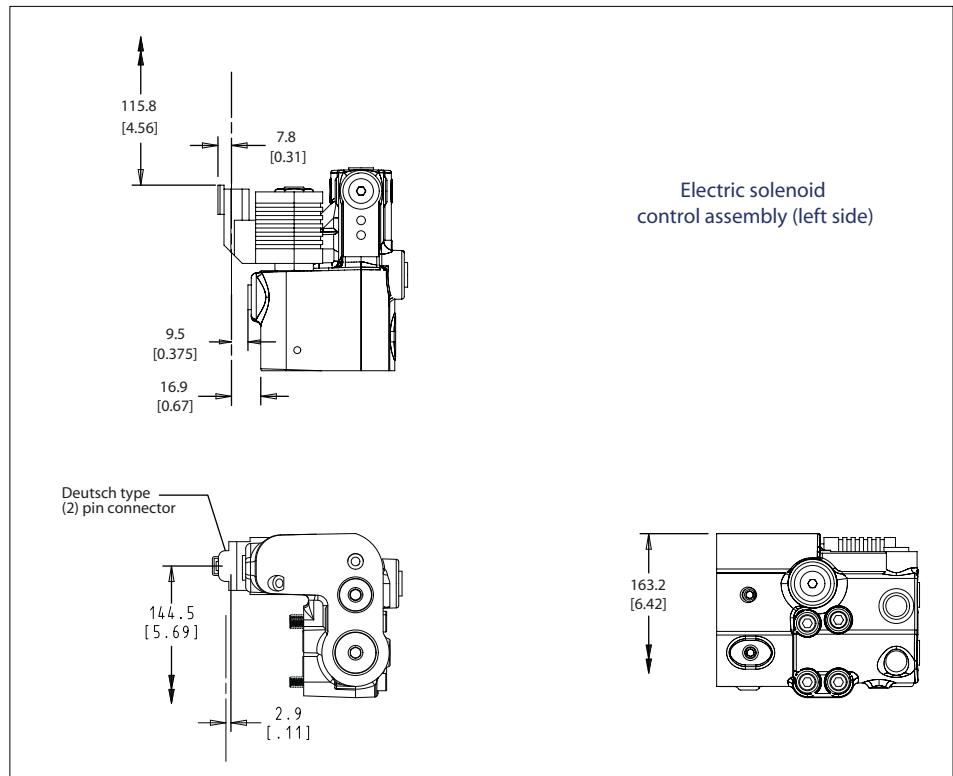
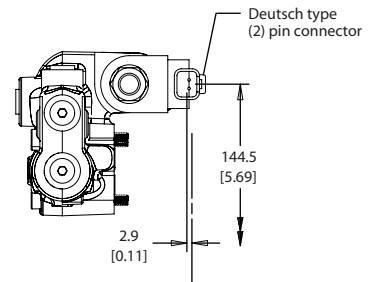
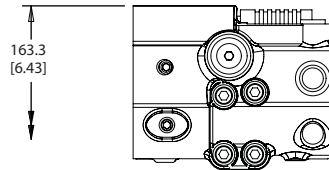
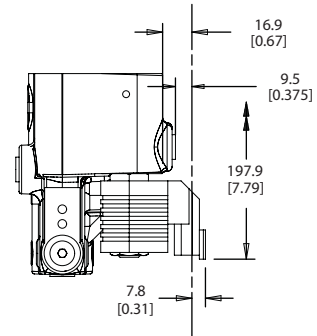

P106 190E

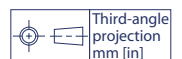

DESIGN

Series 45 Frame J pumps have a single servo piston design with a cradle-type swashplate set in polymer-coated journal bearings. A bias spring and internal forces increase swashplate angle. The servo piston decreases swashplate angle. Nine reciprocating pistons displace fluid from the pump inlet to the pump outlet as the cylinder block rotates on the pump input shaft. The block spring holds the piston slippers to the swashplate via the slipper retainer. The cylinder block rides on a bi-metal valve plate optimized for high volumetric efficiency and low noise. Tapered roller bearings support the input shaft and a viton lip-seal protects against shaft leaks.

An adjustable one spool (PC only, not shown) or two spool (LS and PC) control senses system pressure and load pressure (LS controls). The control ports system pressure to the servo piston to control pump output flow.

Frame J cross section

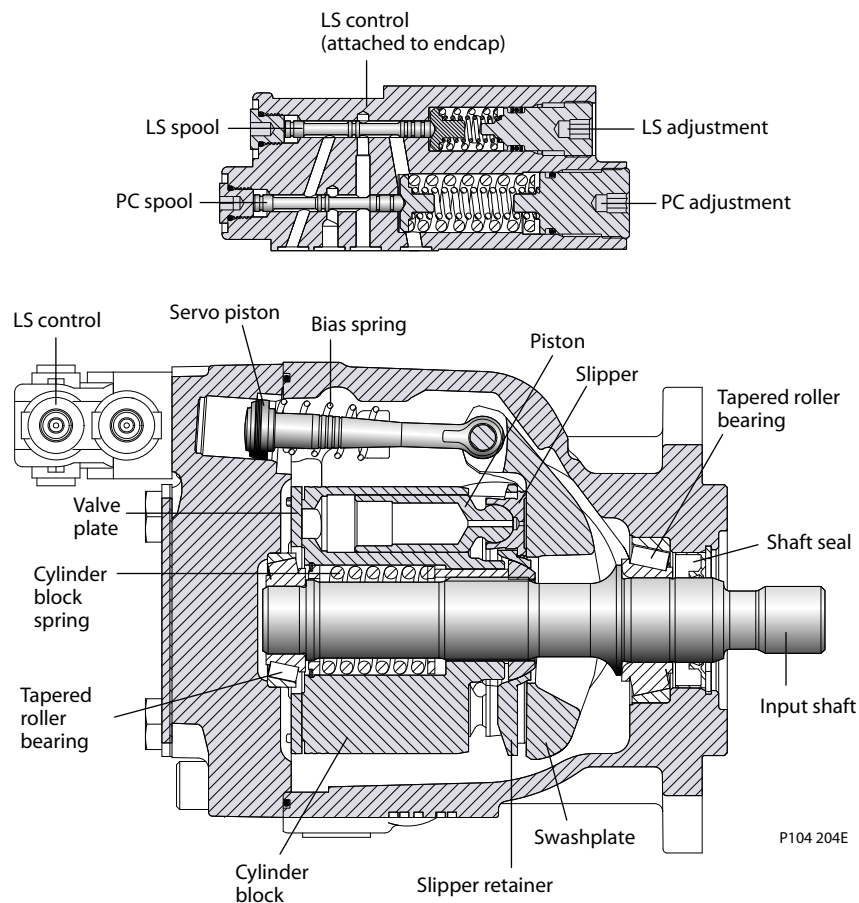

SPECIFICATIONS

For general operating parameters, including fluid viscosity, temperature, and inlet and case pressures, [see page 13](#). For system design parameters, including installation, filtration, reservoir, and line velocities, [see page 15](#).

Features and options

Feature		Unit	Model				
			J45B	J51B	J60B	J65C	J75C
Maximum Displacement		cm ³ [in ³]	45 [2.75]	51 [3.11]	60 [3.66]	65 [3.97]	75 [4.58]
Flow at rated speed (theoretical)		l/min [US gal/min]	126.0 [33.3]	137.7 [36.4]	156.0 [41.2]	162.6 [42.9]	180.0 [47.5]
Input torque at maximum displacement (theoretical)		N•m/bar [lbf•in/1000 psi]	0.716 [436.9]	0.811 [495.1]	0.956 [583.6]	1.035 [631.4]	1.193 [728.1]
Mass moment of inertia of internal rotating components		kg•m ² [slug•ft ²]	0.00455 [0.00336]	0.00455 [0.00336]	0.00455 [0.00336]	0.00433 [0.00319]	0.00433 [0.00319]
Weight	Axial ports	kg [lb]	23.13 [51]				
	Radial ports		26.65 [58.8]				
Rotation			Clockwise, Counterclockwise				
Mounting			2 bolt SAE-B, 4 bolt SAE-C				
Auxiliary mounting (See page 57)			SAE-A, SAE-B, SAE-BB, SAE-C				
System ports (type)			SAE O-ring boss. 4-bolt split flange				
System ports (location)			Axial, Radial				
Control types (See page 51)			AG, AF, PC, Remote PC, LS, LS with internal bleed				
Shafts (See page 54)	Splined		13 tooth, 14 tooth, 15 tooth				
	Tapered		Ø 31.75 mm [1.25 in], 1:8 taper				
	Straight		Ø 31.75 mm [1.25 in]				
Displacement limiters			Contact your Sauer-Danfoss representative				

Ratings

Rating			Model				
			J45B	J51B	J60B	J65C	J75C
Input speed ¹	minimum	min ⁻¹ (rpm)	500	500	500	500	500
	continuous		2800	2700	2600	2500	2400
	maximum		3360	3240	3120	3000	2880
Working pressure	continuous	bar [psi]	310 [4495]	310 [4495]	310 [4495]	260 [3770]	260 [3770]
	maximum		400 [5800]	400 [5800]	400 [5800]	350 [5075]	350 [5075]
External shaft loads	External moment (M _e)	N•m [lbf•in]	226 [2000]	226 [2000]	226 [2000]	226 [2000]	226 [2000]
	Thrust in (T _{in}), out (T _{out})	N [lbf]	2200 [495]	2200 [495]	2200 [495]	2200 [495]	2200 [495]
Bearing life	at 140 bar [2030 psi]	B ₁₀ hours	29 712	29 712	29 712	10 755	10 755
	at 210 bar [3045 psi]		6834	6834	6834	2474	2474
	at 260 bar [3770 psi]		3151	3151	3151	—	—
	at 310 bar [4495 psi]		1666	1666	1666	—	—
Mounting flange load moments	Vibratory (continuous)	N•m [lbf•in]	SAE-C: 1500 [14 000], SAE-B: 735 [6500]				
	Shock (max)		SAE-C: 5600 [50 000], SAE-B: 2600 [23 000]				

1. Continuous input speeds are valid at 1 bar absolute [0 in Hg vac] inlet pressure. Maximum input speeds require changing the inlet pressure or reducing pump displacement. See *Inlet pressure vs. speed* charts.

Sound levels²

For more information on noise levels, [see page 19](#).

dB(A)	210 bar [3045 psi]		260 bar [3770 psi]		310 bar [4495 psi]	
	Model	1800 min ⁻¹ (rpm)	Rated speed	1800 min ⁻¹ (rpm)	Rated speed	1800 min ⁻¹ (rpm)
J45B	75	79	77	80	76	80
J51B	75	79	77	78	77	78
J60B	75	79	77	79	76	79
J65C	75	78	77	77	—	—
J75C	77	78	77	77	—	—

2. Sound data was collected in a *semi-anechoic* chamber. Values have been adjusted (-3 dB) to reflect *anechoic* levels.

PERFORMANCE
J45B

Flow and power data valid at 49°C [120°F] and viscosity of 17.8 mm²/sec [88 SUS].

Flow vs. speed

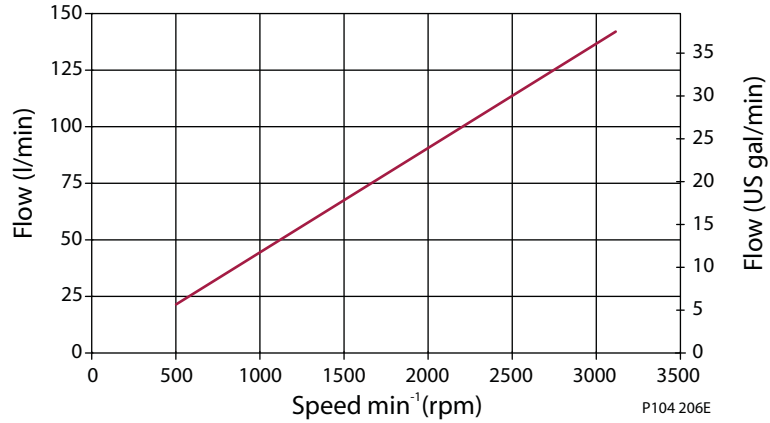

Input power vs. speed

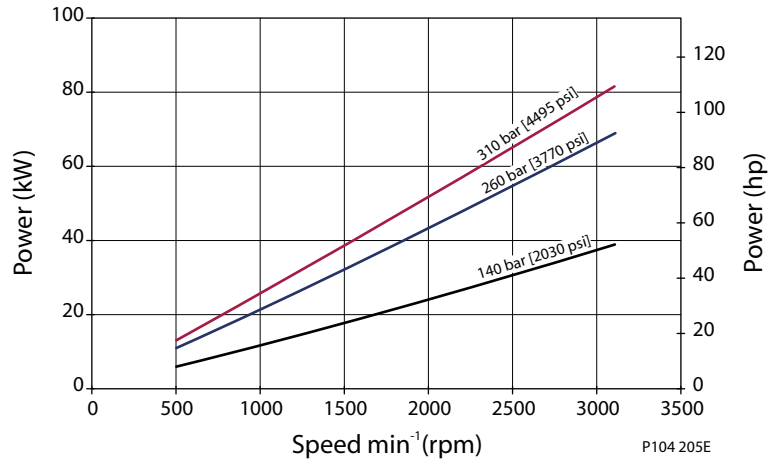

Inlet pressure vs. speed

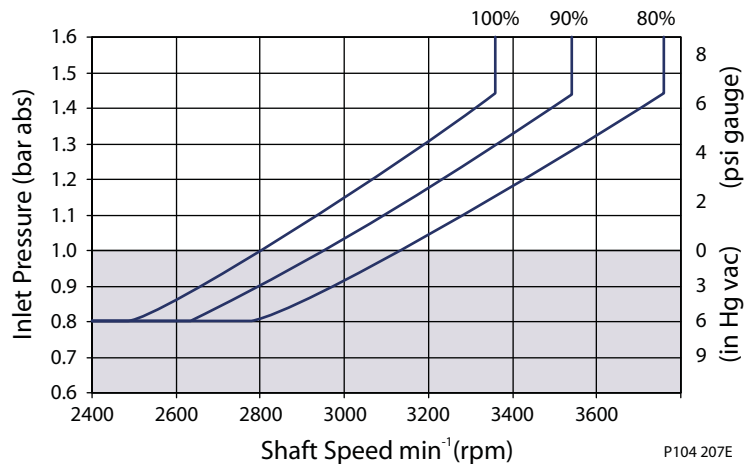

The chart on the right shows allowable inlet pressure and speed at various displacements. Greater speeds and lower inlet pressures are possible at reduced displacement. Operating outside of acceptable limits reduces pump life.

PERFORMANCE
J51B

Flow and power data valid at 49°C [120°F] and viscosity of 17.8 mm²/sec [88 SUS].

Flow vs. speed

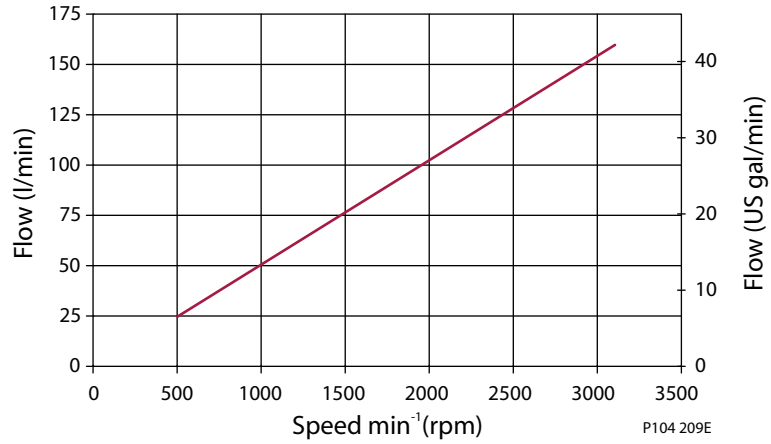

Input power vs. speed

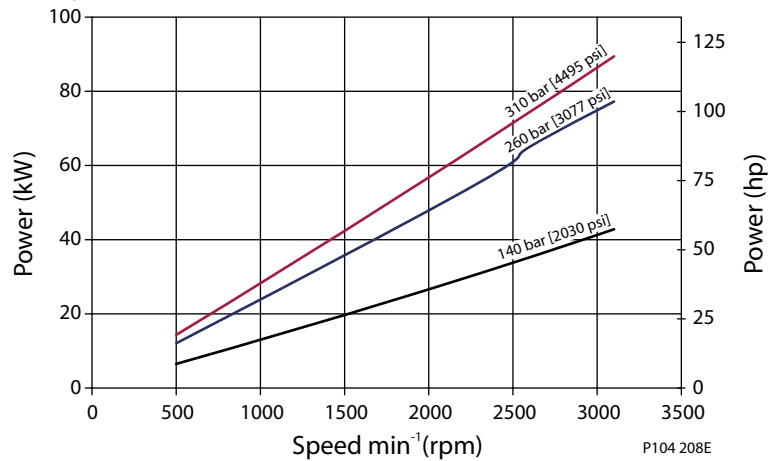

Inlet pressure vs. speed

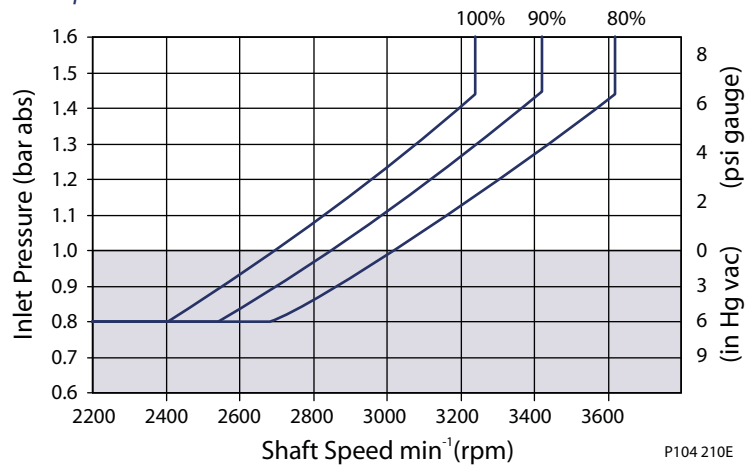

The chart on the right shows allowable inlet pressure and speed at various displacements. Greater speeds and lower inlet pressures are possible at reduced displacement. Operating outside of acceptable limits reduces pump life.

PERFORMANCE
J60B

Flow and power data valid at 49°C [120°F] and viscosity of 17.8 mm²/sec [88 SUS].

Flow vs. speed

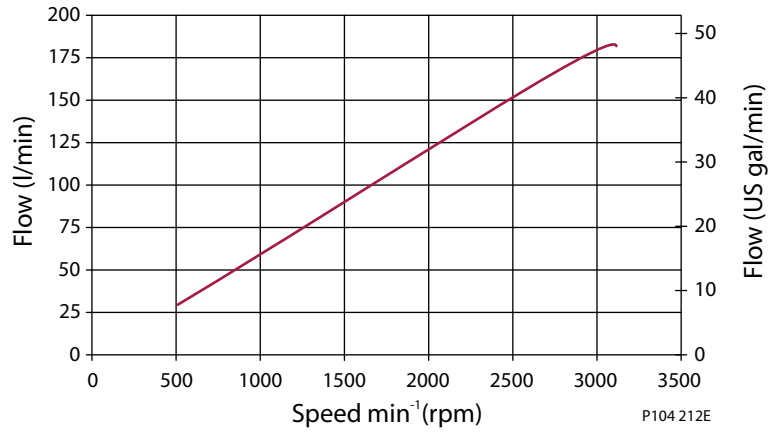

Input power vs. speed

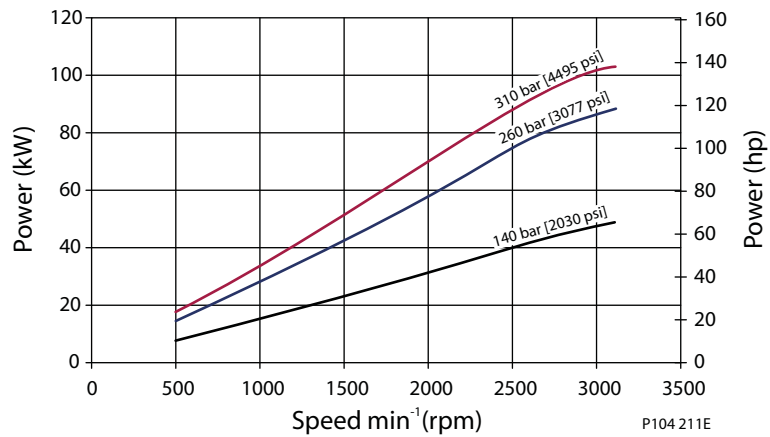

Inlet pressure vs. speed

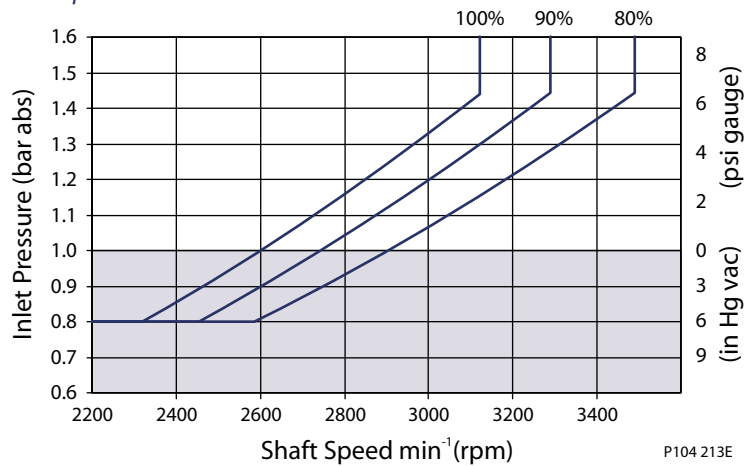

The chart on the right shows allowable inlet pressure and speed at various displacements. Greater speeds and lower inlet pressures are possible at reduced displacement. Operating outside of acceptable limits reduces pump life.

PERFORMANCE
J65C

Flow and power data valid at 49°C [120°F] and viscosity of 17.8 mm²/sec [88 SUS].

Flow vs. speed

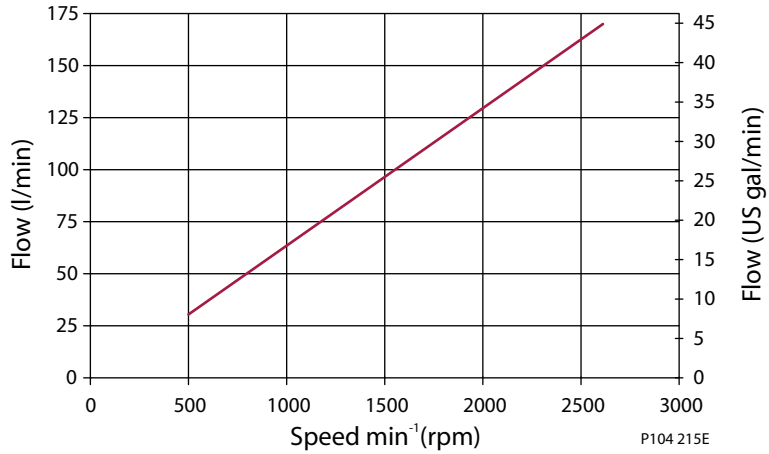

Input power vs. speed

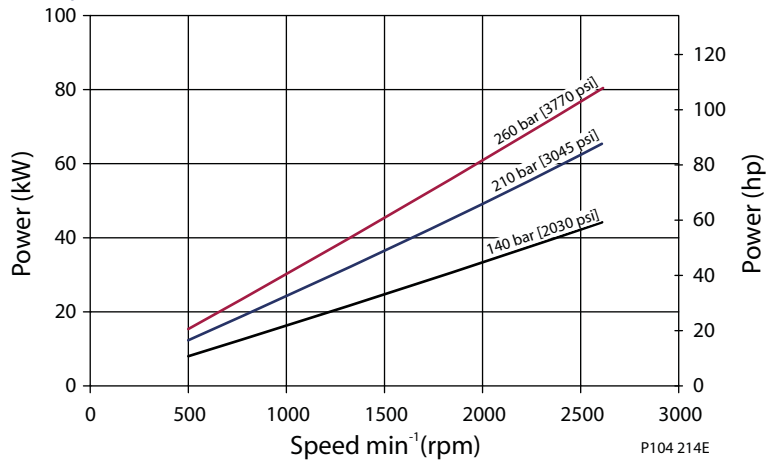

Inlet pressure vs. speed

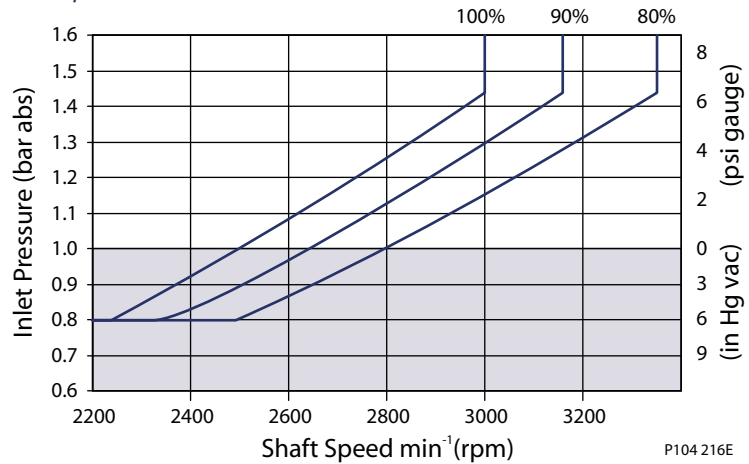

The chart on the right shows allowable inlet pressure and speed at various displacements. Greater speeds and lower inlet pressures are possible at reduced displacement. Operating outside of acceptable limits reduces pump life.

PERFORMANCE
J75C

Flow and power data valid at 49°C [120°F] and viscosity of 17.8 mm²/sec [88 SUS].

Flow vs. speed

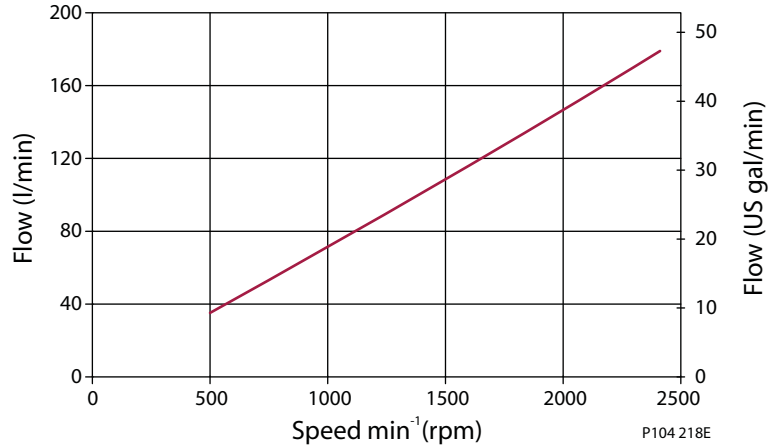

Input power vs. speed

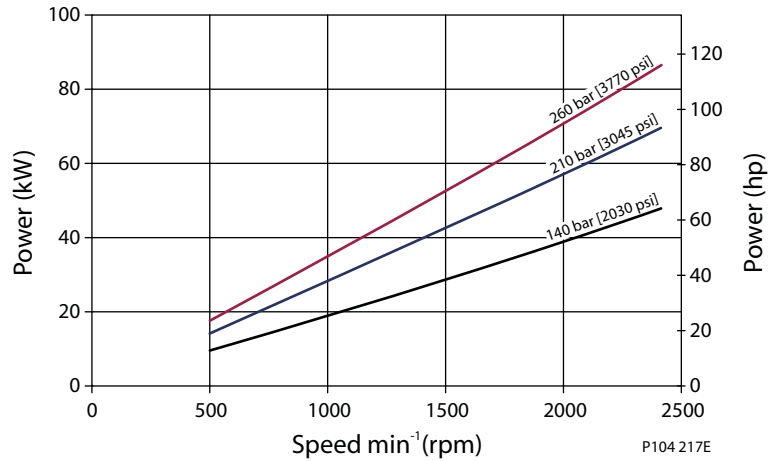

Inlet pressure vs. speed

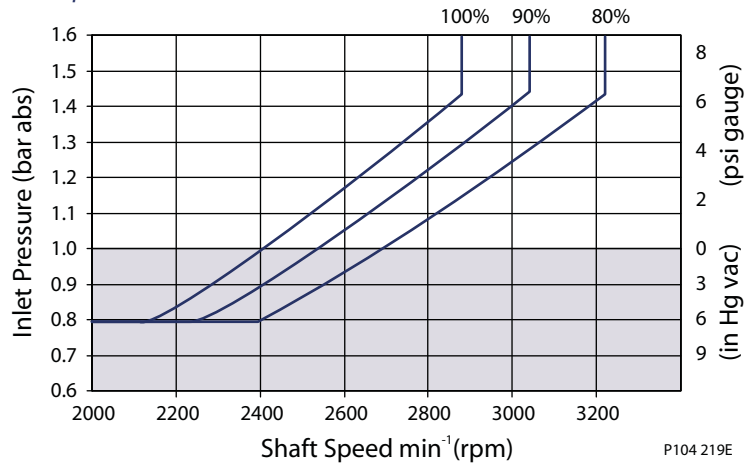

The chart on the right shows allowable inlet pressure and speed at various displacements. Greater speeds and lower inlet pressures are possible at reduced displacement. Operating outside of acceptable limits reduces pump life.

ORDER CODE



R Product

JR	J Frame, variable displacement open circuit pump
-----------	--

S Rotation

L	Left hand (counterclockwise)
R	Right hand (clockwise)

P Displacement and pressure rating

045B	045 cm ³ /rev [2.75 in ³ /rev], 310 bar [4495 psi] continuous working pressure
051B	051 cm ³ /rev [3.11 in ³ /rev], 310 bar [4495 psi] continuous working pressure
060B	060 cm ³ /rev [3.66 in ³ /rev], 310 bar [4495 psi] continuous working pressure
065C	065 cm ³ /rev [3.97 in ³ /rev], 260 bar [3077 psi] continuous working pressure
075C	075 cm ³ /rev [4.58 in ³ /rev], 260 bar [3077 psi] continuous working pressure

C Control type

PC	Pressure compensated control 100-280 bar [1450-4060 psi]
BC*	Pressure compensated control 290-310 bar [4205-4495 psi]
RP	Remote pressure compensated control 100-280 bar [1450-4060 psi]
BP*	Remote pressure compensated control 290-310 bar [4205-4495 psi]
LS	Load sensing / pressure compensating control 100-280 bar [1450-4060 psi]
BS*	Load sensing / pressure compensating control 290-310 bar [4205-4495 psi]
LB	Load sensing / pressure compensating control with internal bleed orifice 100-280 bar [1450-4060 psi]
BB*	Load sensing / pressure compensating control with internal bleed orifice 290-310 bar [4205-4495 psi]
AG	Pressure compensated control with electric on/off solenoid operated 2-way valve (normally closed)
AF	Pressure compensated control with electric on/off solenoid operated 2-way valve (normally open)

* Use only with 45, 51, and 60 cm³ displacements.

D PC setting (2 digit code, 10 bar increments)

Example	10 = 100 bar
10-26	100 to 260 bar [1450 to 3770 psi] (065C and 075C)
10-31	100 to 310 bar [1450 to 4495 psi] (045B, 051B and 060B)

E Load sensing setting (2 digit code, 1 bar increments)

Example	20 = 20 bar
10-30	10 to 30 bar [145 to 435 psi]
NN	Not applicable (use with PC, BC, RP, and BP controls)

F Not used

NN	Not applicable
-----------	----------------

G Pilot orifice

N	None (standard)
----------	-----------------

H Gain orifice

3	Standard orifice
----------	------------------

ORDER CODE
 (continued)



J1 *Input shaft*

C2	13 tooth, 16/32 pitch (ANSI A92.1 1970 - Class 5)
C3	15 tooth, 16/32 pitch (ANSI A92.1 1970 - Class 5)
S1	14 tooth, 12/24 pitch (ANSI A92.1 1970 - Class 5)
K4	Ø 31.75 mm [1.25 in] straight key
TO	Ø 31.75 mm [1.25 in], 1:8 taper

J2 *Auxiliary mounting flange type and coupling*

N	None (Use with axial ported endcap options 2 and 3 below)
A	SAE-A, 9-tooth output spline
B	SAE-B, 13-tooth output spline
C	SAE-C, 14-tooth output spline
T	SAE-A, 11-tooth output spline
V	SAE-BB, 15-tooth output spline
R	Running cover (Radial ported endcap machined for aux. pad. Pad and coupling sold separately.)

J3 *Endcap option (system port size and location)*

Code	Port location	Port type	Inlet size	Outlet size
2	Radial	4-bolt split flange	50.8 mm [2.0 in]	25.4 mm [1.0 in]
3	Axial	O-ring boss	1 7/8 in.	1 5/16 in.
4	Axial	4-bolt split flange	50.8 mm [2.0 in]	25.4 mm [1.0 in]

K1 *Shaft seal*

A	Single lip seal, viton
----------	------------------------

K2 *Mounting flange and housing port style*

2	SAE-C 4-bolt, SAE O-ring boss housing ports
8	SAE-B 2-bolt, SAE O-ring boss housing ports

K3 *Not used*

N	Not applicable
----------	----------------

L *Displacement limiter*

NNN	Consult Sauer-Danfoss representative.
------------	---------------------------------------

M *Special hardware*

NNN	None
------------	------

N *Special features*

NNN	None
------------	------

CONTROLS

Pressure compensated control (PC, BC)

Specifications **PC control setting range**

Model	RP	BP
J45B, J51B, J60B	100-280 bar [1450-4060 psi]	290-310 bar [4205-4495 psi]
J65C, J75C	100-260 bar [1450-3770 bar]	N/A

*Response/recovery times**

(ms)	Response	Recovery
J45B	33	140
J51B	33	150
J60B	39	170
J65B	45	140
J75B	45	150

* For definitions, *see page 9.*

Schematic diagram **PC schematic**

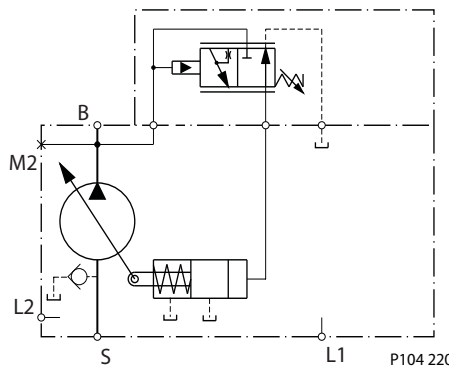

Legend

- B = Outlet
- S = Inlet
- L1, L2 = Case drain
- M2 = System pressure gauge port

Remote PC control (RP, BP)

Specifications **PC control setting range**

Model	RP	BP
J45B, J51B, J60B	100-280 bar [1450-4060 psi]	290-310 bar [4205-4495 psi]
J65C, J75C	100-260 bar [1450-3770 bar]	N/A

*Response/recovery times**

(ms)	Response	Recovery
J45B	33	140
J51B	33	150
J60B	39	170
J65B	45	140
J75B	45	150

* For definitions, *see page 10*

Schematic diagram **Remote PC schematic**

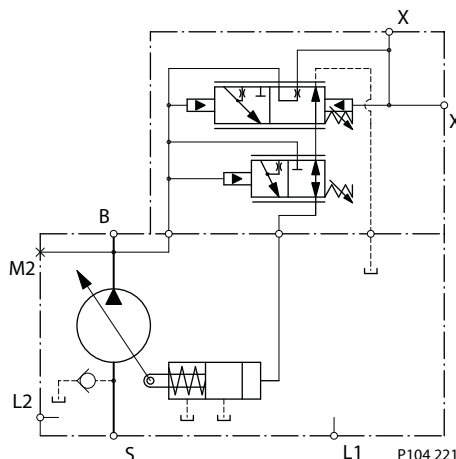

Legend

- B = Outlet
- S = Inlet
- L1, L2 = Case drain
- M2 = System pressure gauge port
- X = Remote PC port

Attach remote PC valve at port X. Size the external valve and plumbing for a pilot flow of 3.8 l/min [1 US gal/min].

CONTROLS
 (continued)

Load sensing control (LS, BS)

Specifications **PC control setting range**

Code	J45B, J51B, J60B	J65C, J75C
LS	100-280 bar [1450-4060 psi]	100-260 bar [1450-3770 bar]
BS	290-310 bar [4205-4495 psi]	N/A

*Response/recovery times**

(MS)	J45B	J51B	J60B	J65B	J75B
Response	28	30	33	43	45
Recovery	111	125	140	101	140

* For definitions, see page 11.

Schematic diagram **LS Schematic**

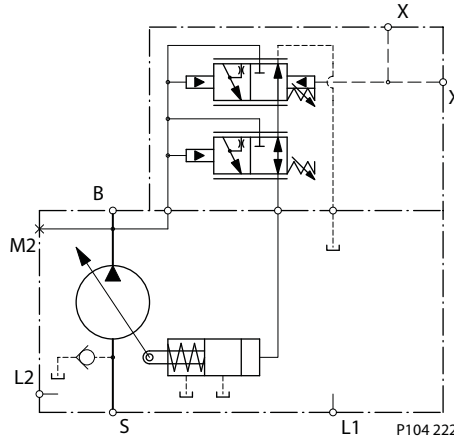

LS setting range

Model	bar	psi
All	10-30	145-435

Legend

- B = Outlet
- S = Inlet
- L1, L2 = Case drain
- M2 = System pressure gauge port
- X = LS signal port

Load sensing control with internal bleed orifice (LB, BB)

Specifications **PC control setting range**

Code	J45B, J51B, J60B	J65C, J75C
LB	100-280 bar [1450-4060 psi]	100-260 bar [1450-3770 bar]
BB	290-310 bar [4205-4495 psi]	N/A

*Response/recovery times**

(MS)	J45B	J51B	J60B	J65B	J75B
Response	28	30	33	43	45
Recovery	111	125	140	101	140

* For definitions, see page 11.

Schematic diagram **LB Schematic**

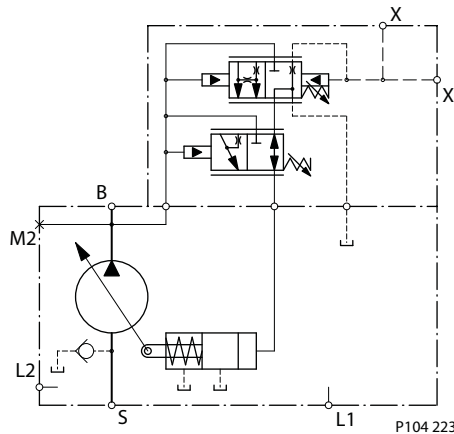

LS setting range

Model	bar	psi
All	10-30	145-435

Legend

- B = Outlet
- S = Inlet
- L1, L2 = Case drain
- M2 = System pressure gauge port
- X = LS signal port

CONTROLS
 (continued)

Normally closed on/off electric PC control (AG)

Specifications *PC control setting range*

Code	J45B, J51B, J60B	J65C, J75C
AG	100-280 bar [1450-4060 psi]	100-260 bar [1450-3770 bar]

*Response/recovery times**

(ms)	J45B	J51B	J60B	J65B	J75B
Response	33	33	39	45	45
Recovery	140	150	170	140	150

* For definitions, see page 12.

Schematic diagram *AG schematic*

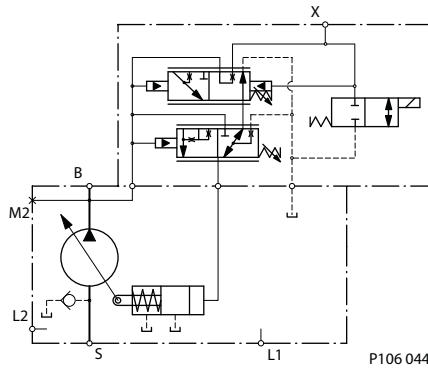

Legend

- B = Outlet
- S = Inlet
- L1, L2 = Case drain
- M2 = System pressure gauge port
- X = Remote PC port

Normally open on/off electric PC control (AF)

Specifications *AF control setting range*

Code	J45B, J51B, J60B	J65C, J75C
AF	100-280 bar [1450-4060 psi]	100-260 bar [1450-3770 bar]

*Response/recovery times**

(ms)	J45B	J51B	J60B	J65B	J75B
Response	33	33	39	45	45
Recovery	140	150	170	140	150

* For definitions, see page 12.

Schematic diagram *AF schematic*

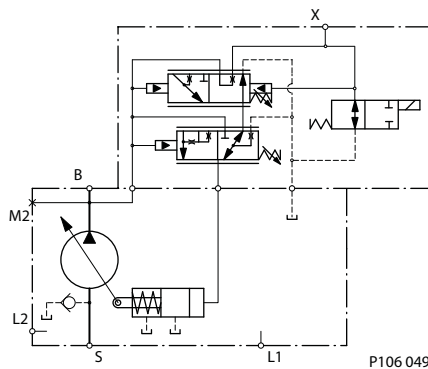

Legend

- B = Outlet
- S = Inlet
- L1, L2 = Case drain
- M2 = System pressure gauge port
- X = Remote PC port

Evaluate your system to decide if normally open or normally closed control override is required for failsafe operation.

INPUT SHAFTS

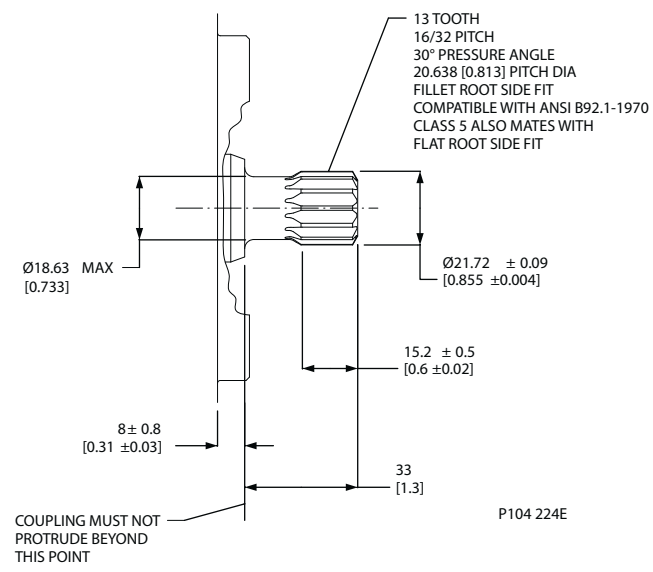
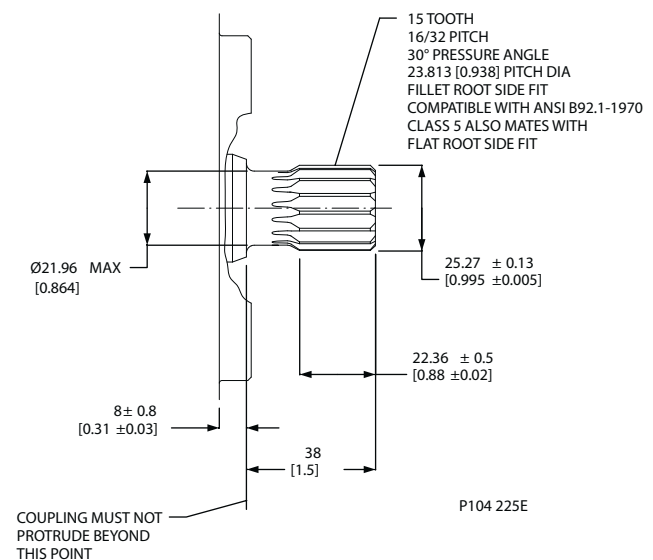
Code	Description	Maximum torque rating ¹ N·m [lbf·in]	Drawing
C2	13 tooth spline 16/32 pitch (ANSI A92.1 1970 - Class 5) <i>For use with SAE-B</i>	288 [2546]	 <p>13 TOOTH 16/32 PITCH 30° PRESSURE ANGLE 20.638 [0.813] PITCH DIA FILLET ROOT SIDE FIT COMPATIBLE WITH ANSI B92.1-1970 CLASS 5 ALSO MATES WITH FLAT ROOT SIDE FIT</p> <p>Ø18.63 MAX [0.733]</p> <p>Ø21.72 ± 0.09 [0.855 ± 0.004]</p> <p>15.2 ± 0.5 [0.6 ± 0.02]</p> <p>8 ± 0.8 [0.31 ± 0.03]</p> <p>33 [1.3]</p> <p>COUPLING MUST NOT PROTRUDE BEYOND THIS POINT</p> <p>P104 224E</p>
C3	15 tooth spline 16/32 pitch (ANSI A92.1 1970 - Class 5) <i>For use with SAE-B</i>	404 [3575]	 <p>15 TOOTH 16/32 PITCH 30° PRESSURE ANGLE 23.813 [0.938] PITCH DIA FILLET ROOT SIDE FIT COMPATIBLE WITH ANSI B92.1-1970 CLASS 5 ALSO MATES WITH FLAT ROOT SIDE FIT</p> <p>Ø21.96 MAX [0.864]</p> <p>25.27 ± 0.13 [0.995 ± 0.005]</p> <p>22.36 ± 0.5 [0.88 ± 0.02]</p> <p>8 ± 0.8 [0.31 ± 0.03]</p> <p>38 [1.5]</p> <p>COUPLING MUST NOT PROTRUDE BEYOND THIS POINT</p> <p>P104 225E</p>

1. See *Input shaft torque ratings*, page 18 for an explanation of maximum torque.

INPUT SHAFTS
 (continued)

Code	Description	Maximum torque rating ¹ N•m [lbf•in]	Drawing
S1	14 tooth spline 12/24 pitch (ANSI A92.1 1970 - Class 5) <i>For use with SAE-C</i>	734 [6495]	
K4	Ø 31.75 mm [1.25 in] straight key <i>For use with SAE-C</i>	655 [5797]	

1. See *Input shaft torque ratings*, page 18 for an explanation of maximum torque.

INPUT SHAFTS
 (continued)

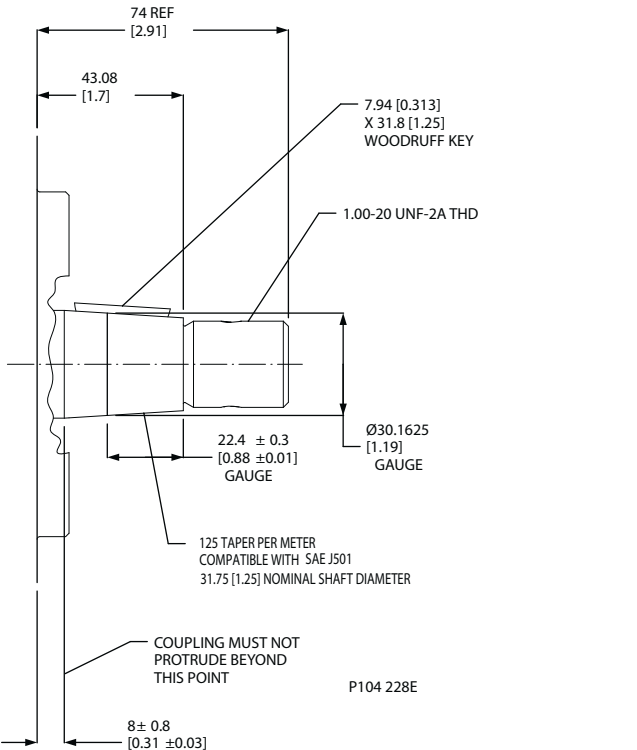
Code	Description	Maximum torque rating ¹ N·m [lb·in]	Drawing
TO	Ø 31.75 mm [1.25 in] 1:8 taper <i>For use with SAE-C</i>	734 [6495]	 <p>74 REF [2.91]</p> <p>43.08 [1.7]</p> <p>7.94 [0.313] X 31.8 [1.25] WOODRUFF KEY</p> <p>1.00-20 UNF-2A THD</p> <p>22.4 ± 0.3 [0.88 ± 0.01] GAUGE</p> <p>Ø30.1625 [1.19] GAUGE</p> <p>125 TAPER PER METER COMPATIBLE WITH SAE J501 31.75 [1.25] NOMINAL SHAFT DIAMETER</p> <p>COUPLING MUST NOT PROTRUDE BEYOND THIS POINT</p> <p>P104 228E</p> <p>8 ± 0.8 [0.31 ± 0.03]</p>

1. See *Input shaft torque ratings*, page 18 for an explanation of maximum torque.

AUXILIARY MOUNTING PADS

See page 18 for mating pump pilot and spline dimensions.

SAE-A auxiliary mounting pad (non-integral)
 Dimensions

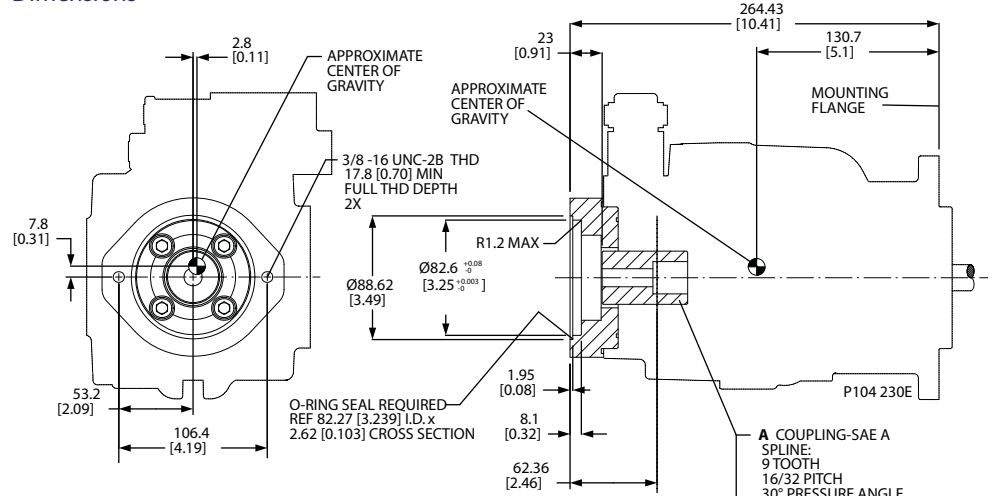

Specifications

Coupling	9-tooth	11-tooth
Spline minimum engagement	13.5 mm [0.53 in]	15 mm [0.59 in]
Maximum torque	107 N·m [950 lbf·in]	147 N·m [1300 lbf·in]

A COUPLING-SAE A
 SPLINE:
 9 TOOTH
 16/32 PITCH
 30° PRESSURE ANGLE
 14.288 [0.5625] PITCH DIA
 FILLET ROOT SIDE FIT
 PER ANSI B92.1-1970 CLASS 6

T COUPLING-SAE A
 SPLINE:
 11 TOOTH
 16/32 PITCH
 30° PRESSURE ANGLE
 17.463 [0.6875] PITCH DIA
 FILLET ROOT SIDE FIT
 PER ANSI B92.1-1970 CLASS 6

SAE-B auxiliary mounting pad
 Dimensions

See page 18 for mating pump pilot and spline dimensions.

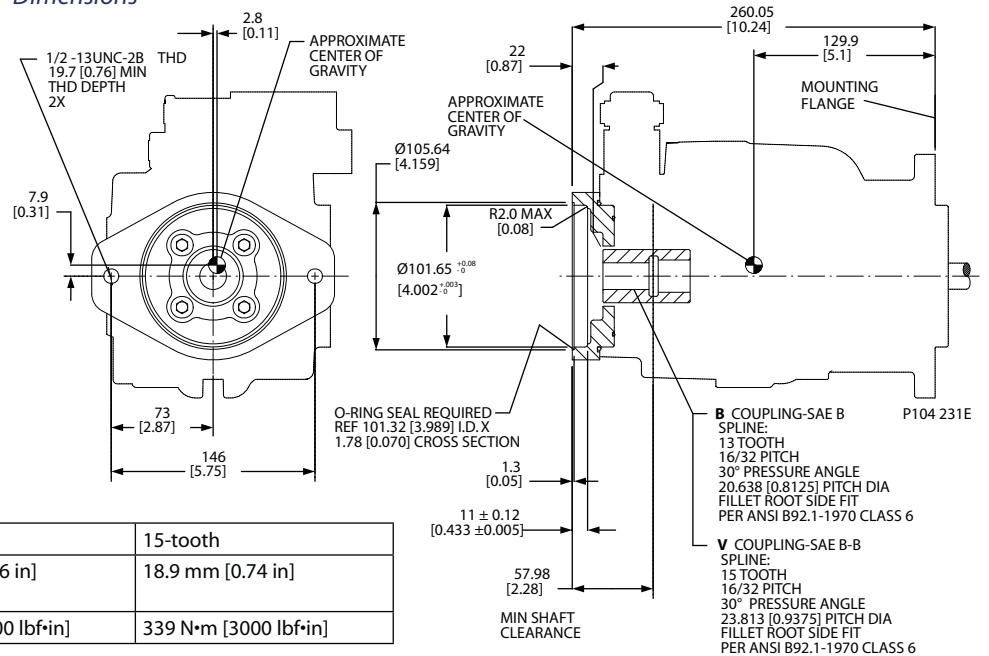

Specifications

Coupling	13-tooth	15-tooth
Spline minimum engagement	14.2 mm [0.56 in]	18.9 mm [0.74 in]
Maximum torque	249 N·m [2200 lbf·in]	339 N·m [3000 lbf·in]

B COUPLING-SAE B
 SPLINE:
 13 TOOTH
 16/32 PITCH
 30° PRESSURE ANGLE
 20.638 [0.8125] PITCH DIA
 FILLET ROOT SIDE FIT
 PER ANSI B92.1-1970 CLASS 6

V COUPLING-SAE B-B
 SPLINE:
 15 TOOTH
 16/32 PITCH
 30° PRESSURE ANGLE
 23.813 [0.9375] PITCH DIA
 FILLET ROOT SIDE FIT
 PER ANSI B92.1-1970 CLASS 6

AUXILIARY MOUNTING PADS (continued)

See page 18 for mating pump pilot and spline dimensions.

SAE-C auxiliary mounting pad Dimensions

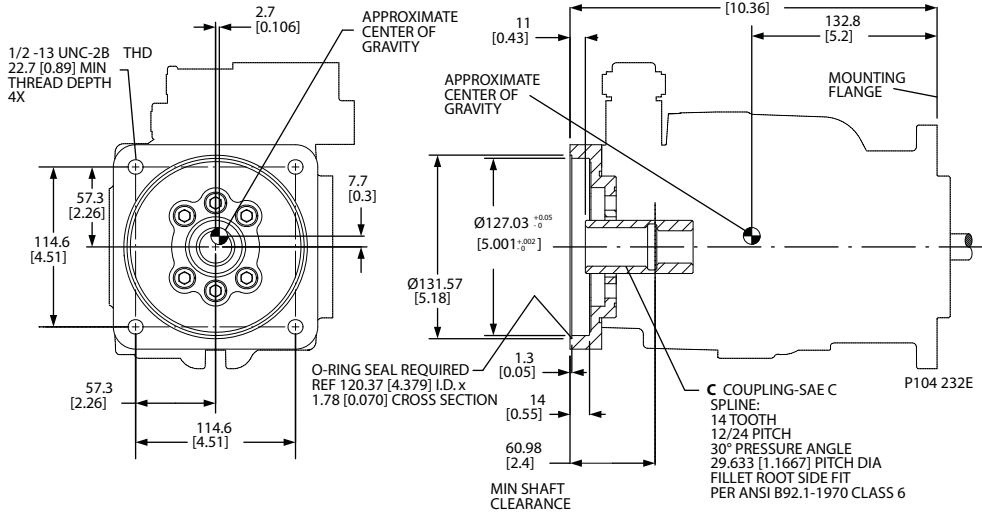

Specifications

Coupling	14-tooth
Spline minimum engagement	18.3 mm [0.72 in]
Maximum torque	339 N·m [3000 lbf·in]

Running cover

Endcap and shaft machined to accommodate auxiliary mounting pads; pad and coupling not included. Conversion kits are available for installation in the field.

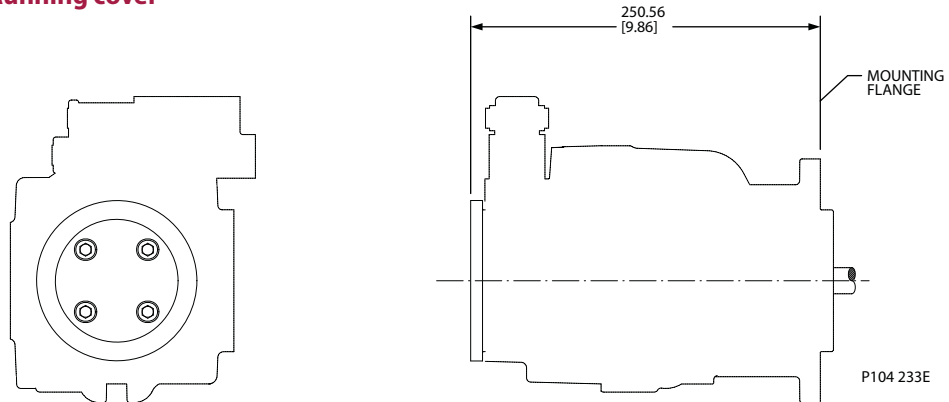

DISPLACEMENT LIMITER

For information on the J Frame displacement limiter, contact your Sauer-Danfoss representative.

**INSTALLATION
DRAWINGS**

Axial ported endcap

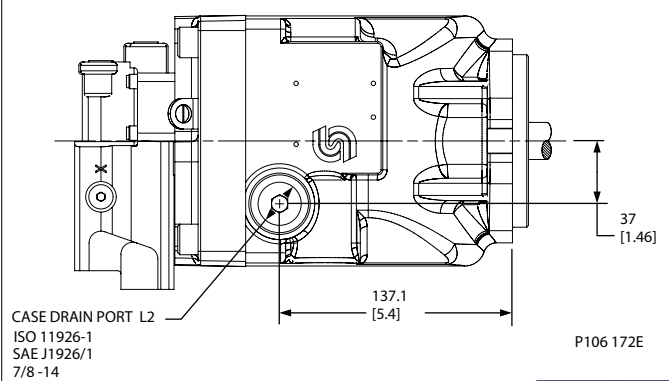
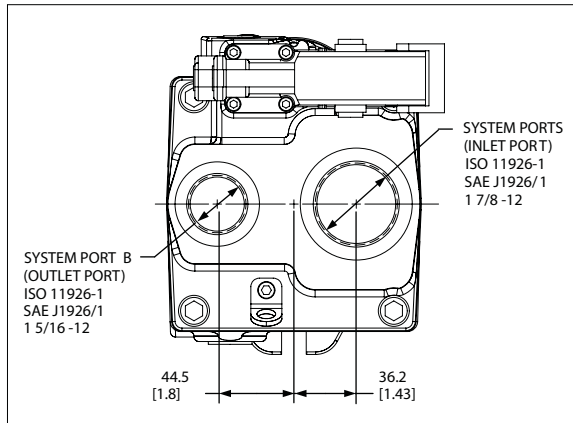
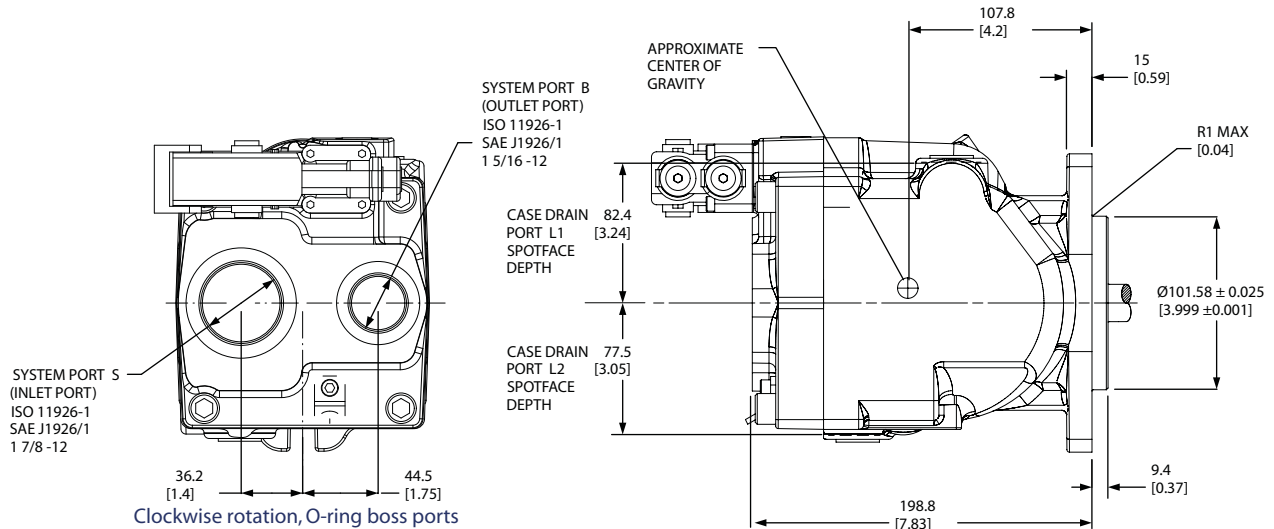
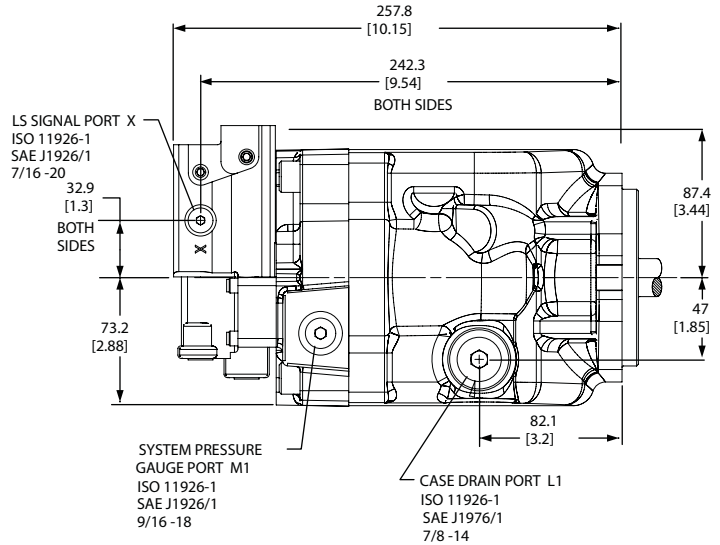

Counterclockwise rotation, O-ring boss ports



**INSTALLATION
DRAWINGS
(continued)**

Axial ported endcap (continued)

The drawings on these pages show a pump with two-bolt SAE-B mounting flange. This pump is also available with a four-bolt SAE-C mounting flange. The differences are detailed in the drawing to the right. All other dimensions are common.

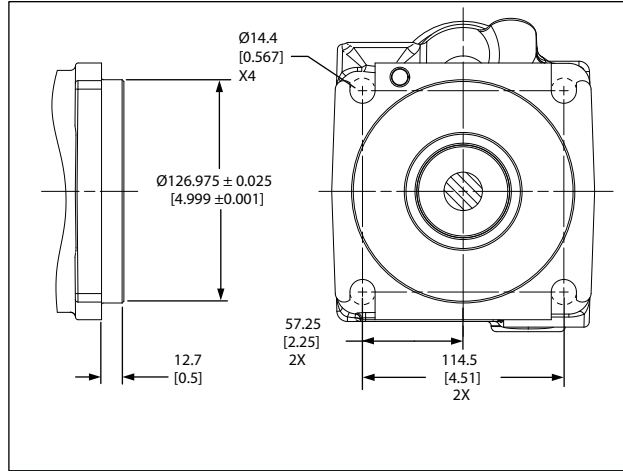

SAE-C four-bolt housing

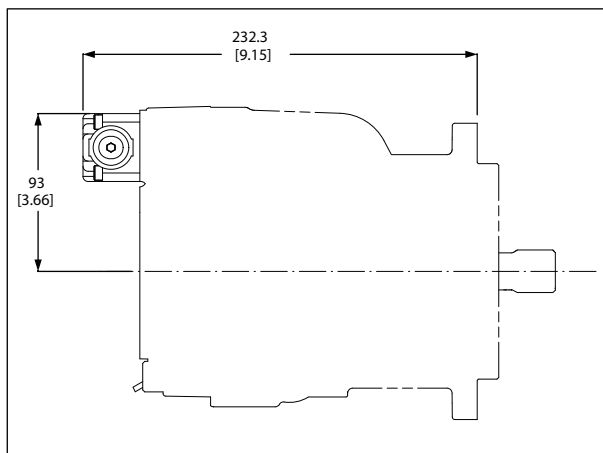
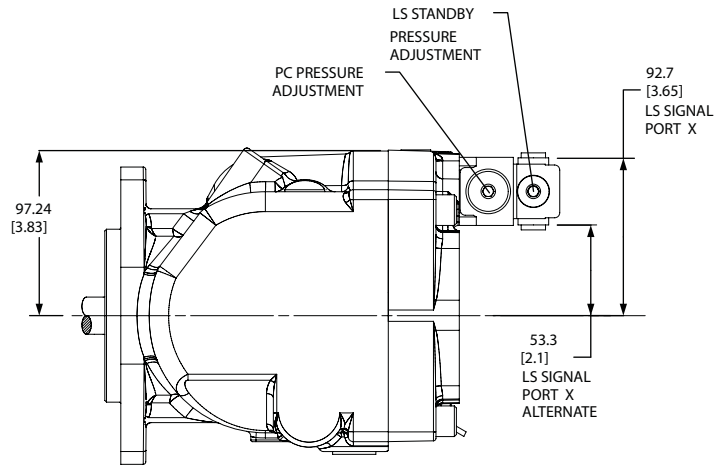
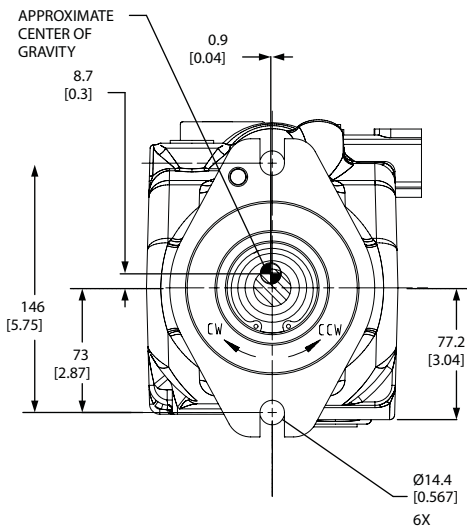

PC only control

P104 234E



**INSTALLATION
 DRAWINGS
 (continued)**

Axial ported endcap (continued)

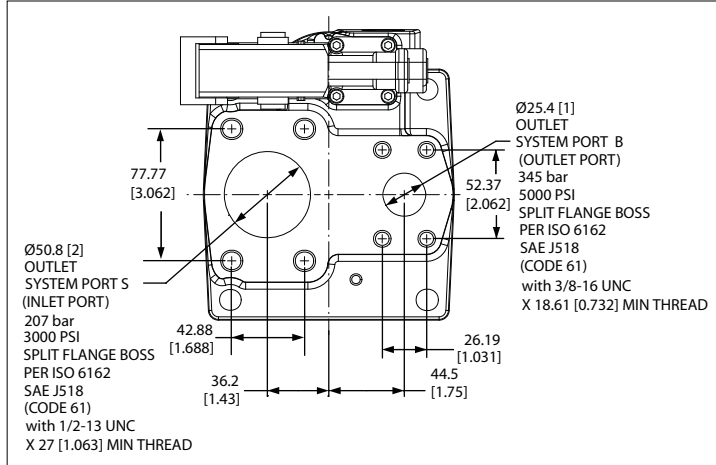

Clockwise rotation, split-flange ports

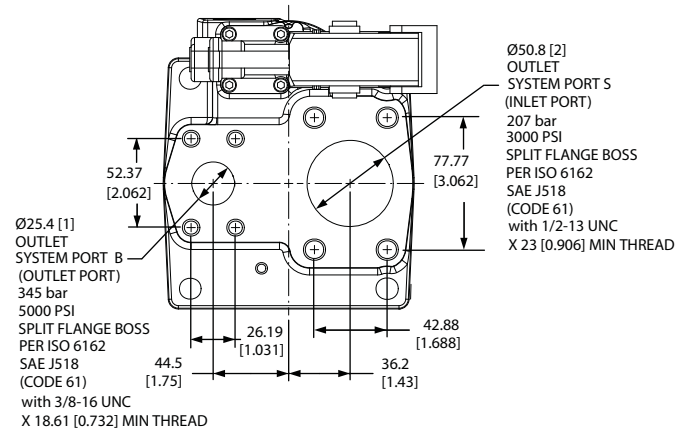

P104 235E

Counter clockwise rotation, split-flange ports

INSTALLATION DRAWINGS

Radial ported endcap

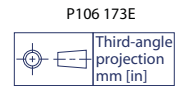
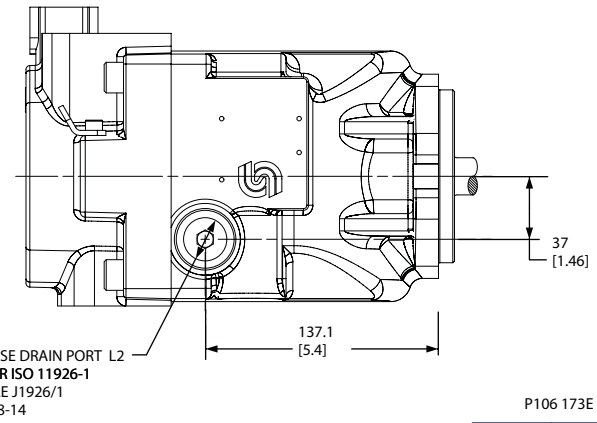
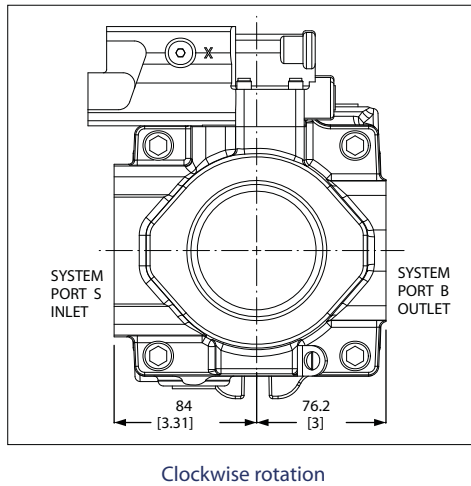
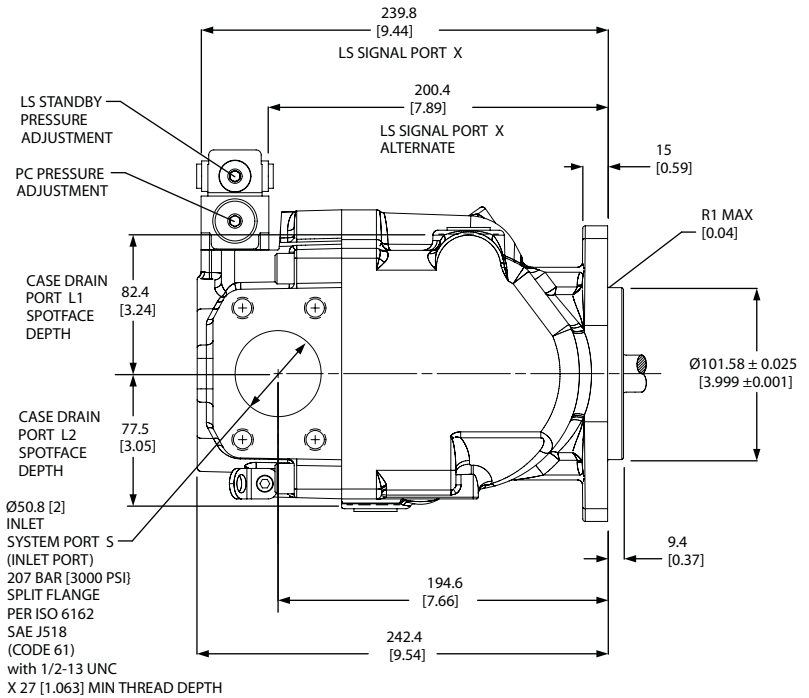
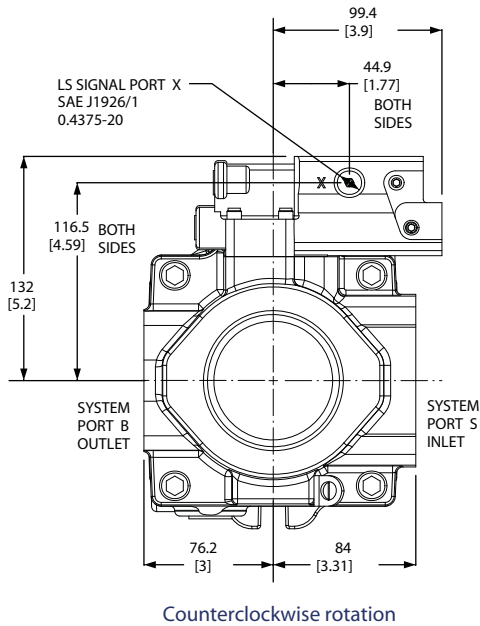
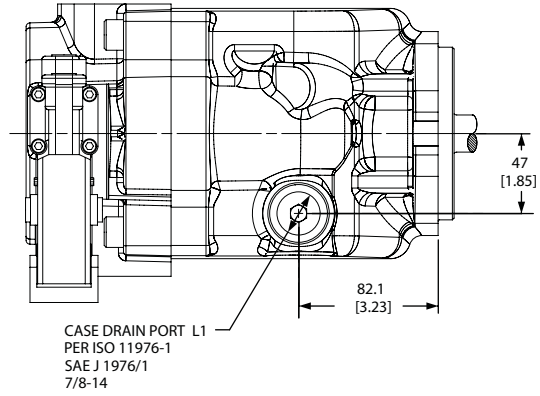

**INSTALLATION
 DRAWINGS
 (continued)**

Radial ported endcap (continued)

The drawings on these pages show a pump with two-bolt SAE-B mounting flange. This pump is also available with a four-bolt SAE-C mounting flange. The differences are detailed in the drawing to the right. All other dimensions are common.

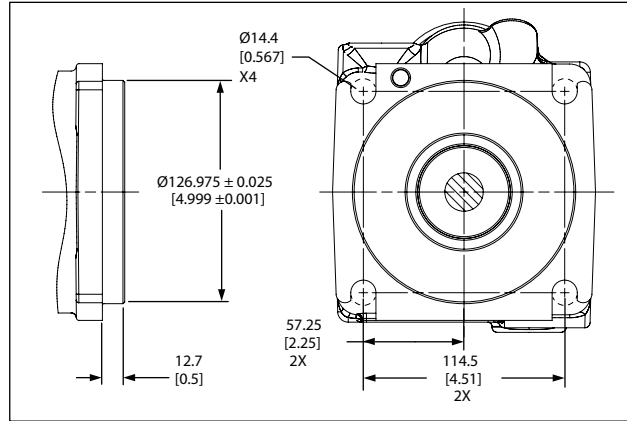

SAE-C four-bolt housing

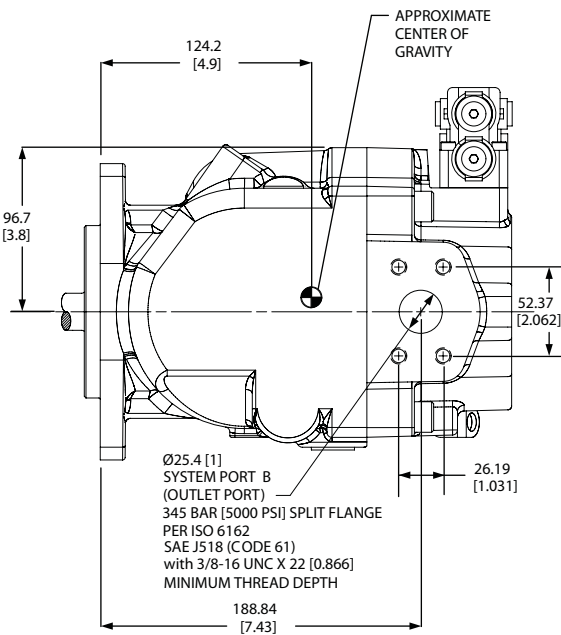
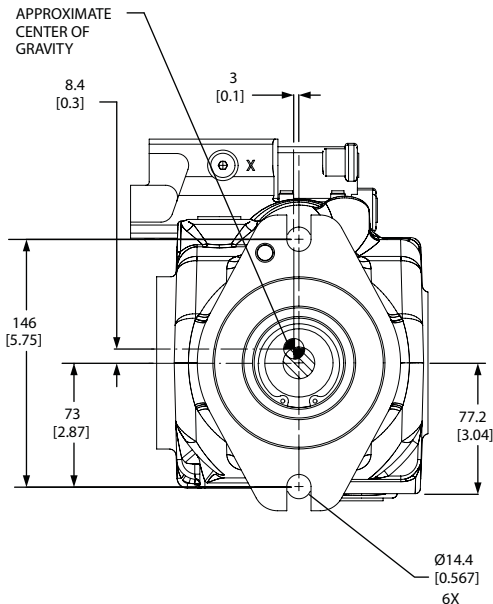

P104 236E

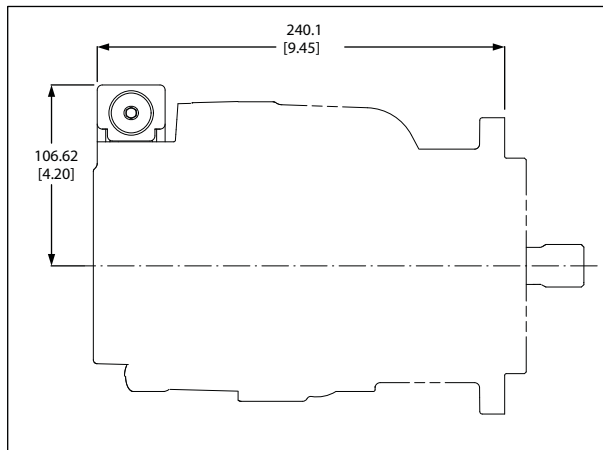

PC only control



**INSTALLATION
DRAWINGS
(continued)**

Electric on/off control

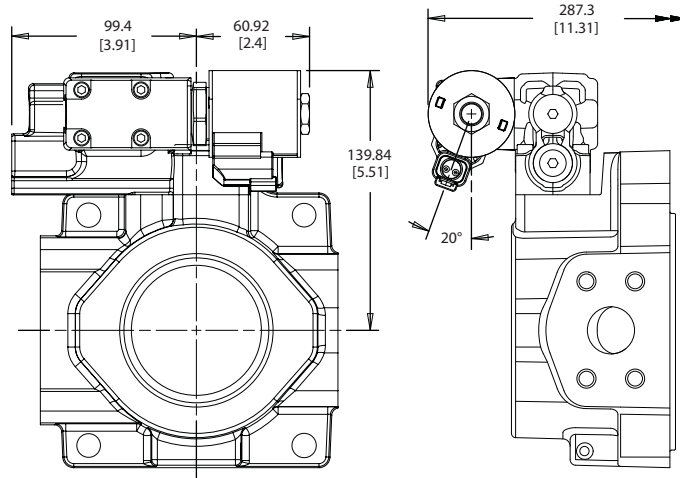

Radial endcap with electric on/off right control (clockwise)

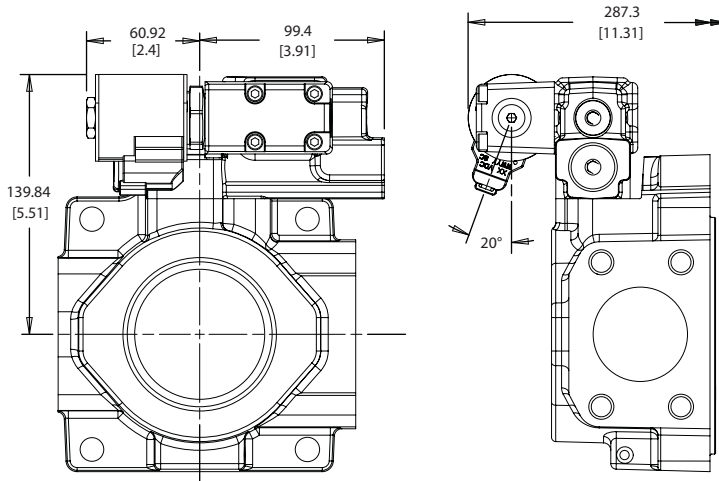

Radial endcap with electric on/off left control (counterclockwise)

P106 191E



Third-angle
projection
mm [in]

DESIGN

Series 45 Frame G pumps have a dual servo piston design with a cradle-type swashplate set in polymer-coated journal bearings. The bias piston increases swashplate angle. The displacement piston decreases swashplate angle. At equal pressure, the larger diameter displacement piston overpowers the bias piston. Nine reciprocating pistons displace fluid from the pump inlet to the pump outlet as the cylinder block rotates on the pump input shaft. The block spring holds the piston slippers to the swashplate via the slipper retainer. The cylinder block rides on a bi-metal valve plate optimized for high volumetric efficiency and low noise. Tapered roller bearings support the input shaft and a viton lip-seal protects against shaft leaks.

An adjustable one spool (PC only, not shown) or two spool (LS) control senses system pressure and load pressure (LS controls). The control ports system pressure to the displacement piston to control pump output flow.

Frame G cross section

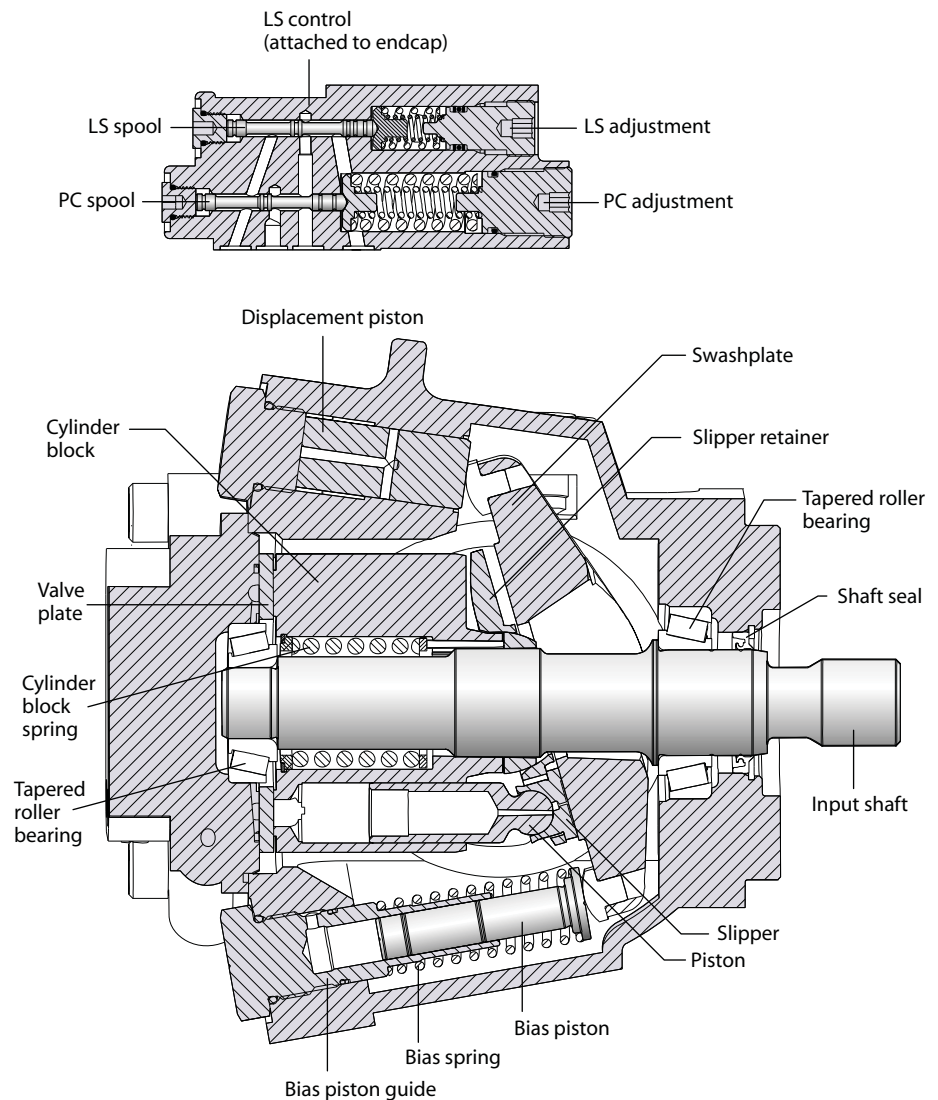

P104 002E

SPECIFICATIONS

For general operating parameters, including fluid viscosity, temperature, and inlet and case pressures, *see page 13*. For system design parameters, including installation, filtration, reservoir, and line velocities, *see page 15*.

Features and options		Model	
		G74B	G90C
Maximum Displacement	cm ³ [in ³]	74 [4.52]	90 [5.49]
Flow at rated speed (theoretical)	l/min [US gal/min]	177.6 [46.9]	198 [52.3]
Input torque at maximum displacement (theoretical)	N•m/bar [lbf•in/1000 psi]	1.178 [719]	1.432 [874]
Mass moment of inertia of internal rotating components	kg•m ² [slug•ft ²]	0.00630 [0.00465]	0.00650 [0.00480]
Weight	Axial ports	29 [63]	
	Radial ports	36 [80]	
Rotation		Clockwise, Counterclockwise	
Mounting		SAE-C	
Auxiliary mounting (See page 74)		SAE-A, SAE-B, SAE-BB, SAE-C	
System ports (type)		4-bolt split flange	
System ports (location)		Axial, Radial	
Control types (See page 71)		PC, Remote PC, LS, LS with internal bleed	
Shafts (See page 73)	Splined	14 tooth, 17 tooth	
	Straight	Ø 31.75 mm [1.25 in]	
Displacement limiters (See page 75)		Optional, adjustable	

For definitions of pressure and speed ratings, *see page 14*. For more information on external shaft loads, *see page 16*; mounting flange loads, *see page 17*.

Ratings			Model	
			G74B	G90C
Input speed ¹	minimum	min ⁻¹ (rpm)	500	500
	continuous		2400	2200
	maximum		2800	2600
Working pressure	continuous	bar [psi]	310 [4495]	260 [3770]
	maximum		400 [5800]	350 [5075]
External shaft loads	External moment (M _e)	N•m [lbf•in]	300 [2655]	
	Thrust in (T _m), out (T _{out})	N [lbf]	2900 [650]	
Bearing life	at 140 bar [2030 psi]	B ₁₀ hours	41 383	19 847
	at 210 bar [3045 psi]		9048	4339
	at 260 bar [3770 psi]		4062	1948
	at 310 bar [4495 psi]		2101	—
Mounting flange load moments	Vibratory (continuous)	N•m [lbf•in]	1580 [14 000]	
	Shock (max)		5650 [50 000]	

1. Input speeds are valid at 1 bar absolute [0 in Hg vac] inlet pressure. See *Inlet pressure vs. speed* charts.

Sound levels²

For more information on noise levels, *see page 19*.

dB(A)	210 bar [3045 psi]		260 bar [3770 psi]		310 bar [4495 psi]		
	Model	1800 min ⁻¹ (rpm)	Rated speed	1800 min ⁻¹ (rpm)	Rated speed	1800 min ⁻¹ (rpm)	Rated speed
G74B		75	78	74	76	75	77
C90C		74	76	75	77	—	—

2. Sound data was collected in a *semi-anechoic* chamber. Values have been adjusted (-3 dB) to reflect *anechoic* levels.

PERFORMANCE
G74B

Flow and power data valid at 49°C [120°F] and viscosity of 17.8 mm²/sec [88 SUS].

Flow vs. speed

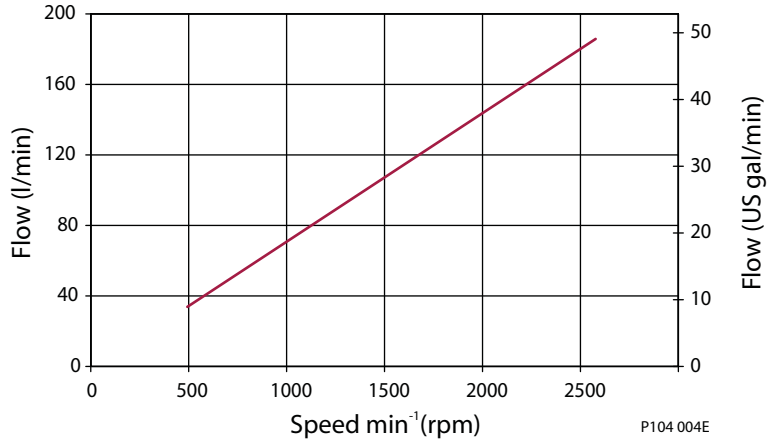

Input power vs. speed

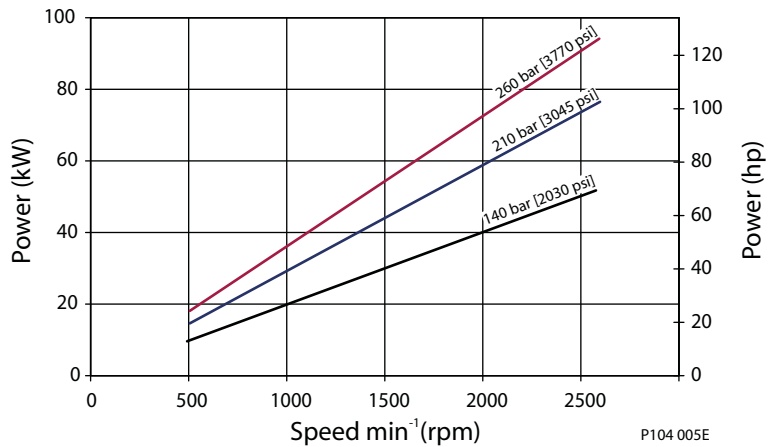

Inlet pressure vs. speed

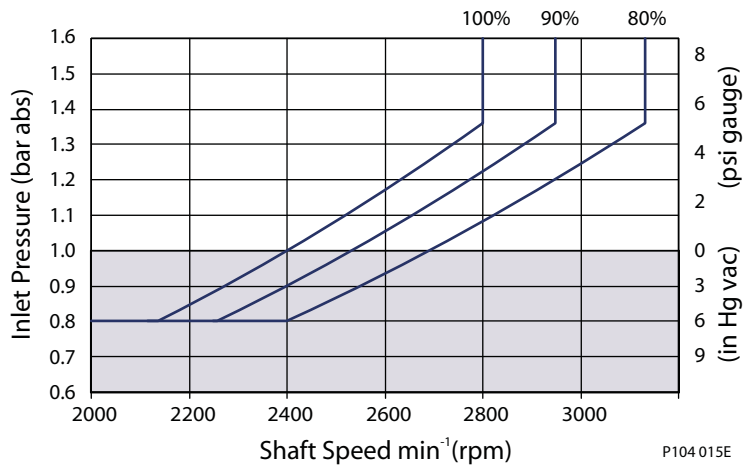

The chart on the right shows allowable inlet pressure and speed at various displacements. Greater speeds and lower inlet pressures are possible at reduced displacement. Operating outside of acceptable limits reduces pump life.

PERFORMANCE
G90C

Flow and power data valid at 49°C [120°F] and viscosity of 17.8 mm²/sec [88 SUS].

Flow vs. speed

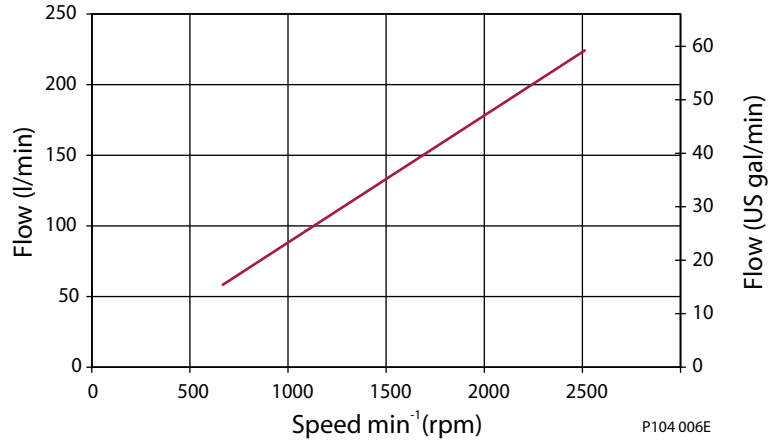

Input power vs. speed

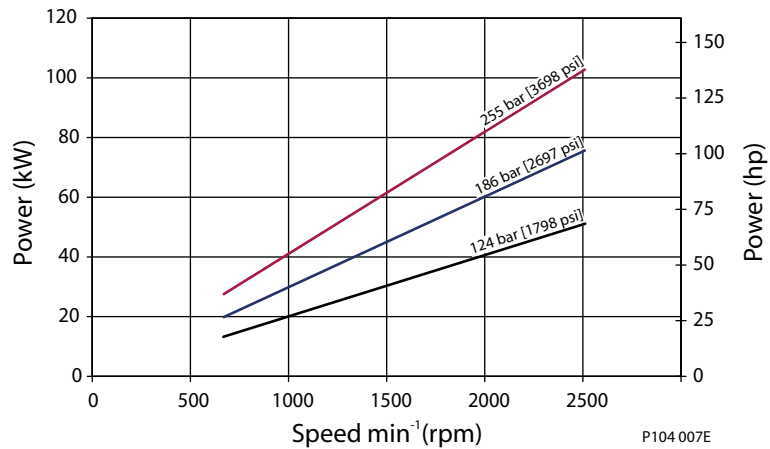

Inlet pressure vs. speed

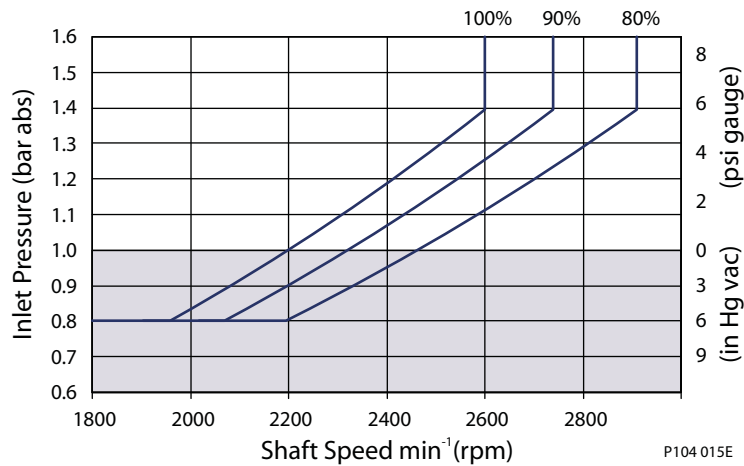

The chart on the right shows allowable inlet pressure and speed at various displacements. Greater speeds and lower inlet pressures are possible at reduced displacement. Operating outside of acceptable limits reduces pump life.

ORDER CODE



R Product

GR	G Frame, variable displacement open circuit pump
-----------	--

S Rotation

L	Left hand (counterclockwise)
R	Right hand (clockwise)

P Displacement and pressure rating

074B	074 cm ³ /rev [4.52 in ³ /rev], 310 bar [4495 psi] continuous working pressure
090C	090 cm ³ /rev [5.49 in ³ /rev], 260 bar [3770 psi] continuous working pressure

C Control type

PC	Pressure compensated control 100-280 bar [1450-4060 psi]
BC	Pressure compensated control 290-310 bar [4205-4495 psi]
RP	Remote pressure compensated control 100-280 bar [1450-4060 psi]
BP	Remote pressure compensated control 290-310 bar [4205-4495 psi]
LS	Load sensing / pressure compensating control 100-280 bar [1450-4060 psi]
BS	Load sensing / pressure compensating control 290-310 bar [4205-4495 psi]
LB	Load sensing / pressure compensating control with internal bleed orifice 100-280 bar [1450-4060 psi]
BB	Load sensing / pressure compensating control with internal bleed orifice 290-310 bar [4205-4495 psi]

D PC setting (2 digit code, 10 bar increments)

Example	10 = 100 bar
10-31	100 to 310 bar [1450 to 4495 psi] (074B)
10-26	100 to 260 bar [1450 to 3770 psi] (090C)

E Load sensing setting (2 digit code, 1 bar increments)

Example	20 = 20 bar
10-30	10 to 40 bar [145 to 435 psi]
NN	Not applicable (use with PC controls)

F Not used

NN	Not applicable
-----------	----------------

ORDER CODE
 (continued)



G Pilot orifice

N	Standard
----------	----------

H Gain orifice

3	Standard
----------	----------

J1 Input shaft

S1	14 tooth, 12/24 pitch (ANSI B92.1 1970 - Class 5)
S2	17 tooth, 12/24 pitch (ANSI B92.1 1970 - Class 5)
K4	Ø 31.75 mm [1.25 in], straight keyed

J2 Auxiliary mounting flange

N	None
A	SAE-A, 9-tooth coupling
T	SAE-A, 11-tooth coupling
B	SAE-B, 13-tooth coupling
V	SAE-BB, 15-tooth coupling
C	SAE-C, 14-tooth coupling

J3 System port size and location

Code	Location	Port type	Inlet size	Outlet size
2	Radial	4-bolt split-flange	2 in.	1 in.
4	Axial	4-bolt split-flange	2 in.	1 in.

K1 Shaft seal

A	Single lip seal, viton
----------	------------------------

K2 Mounting flange and housing port style

1	SAE-C 4-bolt, SAE O-ring boss housing ports
----------	---

K3 Not used

N	Not applicable
----------	----------------

L Displacement limiter

NNN	None
AAA	Adjustable, factory set at max angle (074B)
CAA	Adjustable, factory set at max angle (090C)

M Special hardware

NNN	None
------------	------

N Special features

NNN	None
------------	------

CONTROLS

Pressure compensated control (PC)

Specifications *PC control setting range*

Model	bar	psi
G74B	100–310	1450–4495
G90C	100–260	1450–3770

*Response/recovery times**

(ms)	Response	Recovery
G74B	35	130
G90C	40	140

* For definitions, *see page 9.*

Schematic diagram *PC schematic*

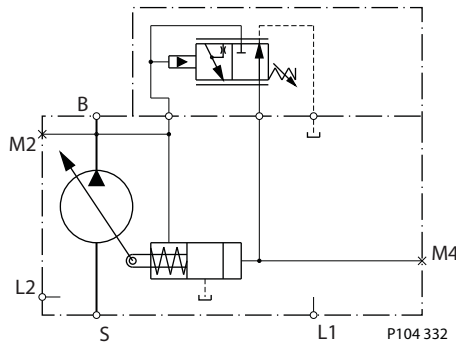

Legend

- B = Outlet
- S = Inlet
- L1, L2 = Case drain
- M2 = System pressure gauge port
- M4 = Servo pressure gauge port

Remote PC control (RP)

Specifications *PC control setting range*

Model	bar	psi
G74B	100–310	1450–4495
G90C	100–260	1450–3770

*Response/recovery times**

(ms)	Response	Recovery
G74B	35	130
G90C	40	140

* For definitions, *see page 10.*

Schematic diagram *Remote PC schematic*

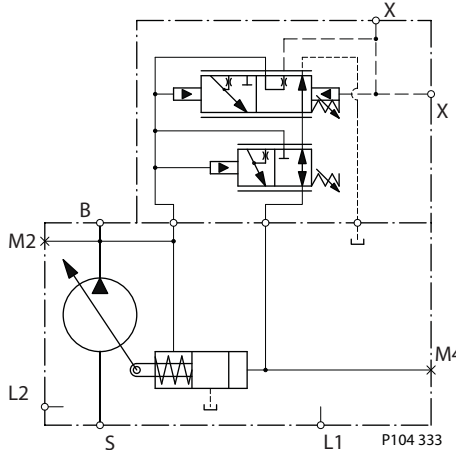

Legend

- B = Outlet
- S = Inlet
- L1, L2 = Case drain
- M2 = System pressure gauge port
- M4 = Servo pressure gauge port
- X = Remote PC port

CONTROLS
 (continued)

Specifications

Load sensing control (LS)

PC setting range

Model	bar	psi
G74B	100–310	1450–4495
G90C	100–260	1450–3770

*Response/recovery times**

(ms)	Response	Recovery
G74B	35	100
G90C	40	130

* For definitions, see page 11

Schematic diagram

LS Schematic

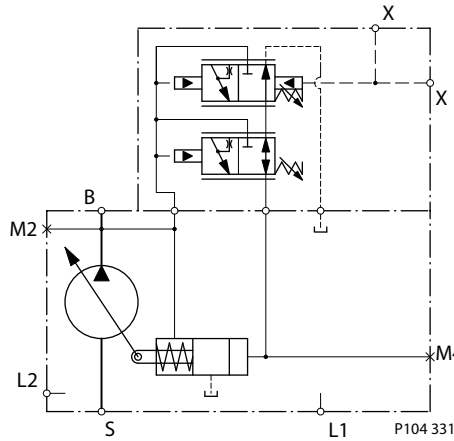

LS setting range

Model	bar	psi
All	10–30	145–435

Legend

- B = Outlet
- S = Inlet
- L1, L2 = Case drain
- M2 = System pressure gauge port
- M4 = Servo pressure gauge port
- X = LS signal port

Load sensing control with internal bleed orifice (LB)

Specifications

PC setting range

Model	bar	psi
G74B	100–310	1450–4495
G90C	100–260	1450–3770

*Response/recovery times**

(ms)	Response	Recovery
G74B	35	100
G90C	40	130

* For definitions, see page 11.

Schematic diagram

LB Schematic

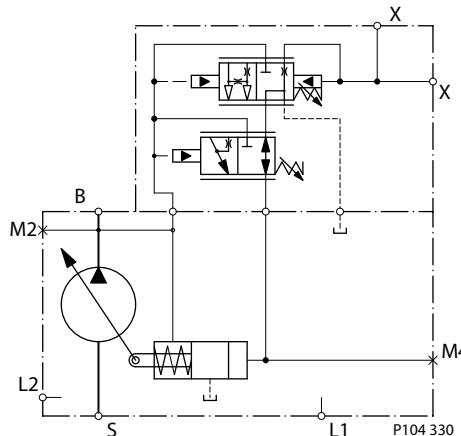

LS setting range

Model	bar	psi
All	10–30	145–435

Legend

- B = Outlet
- S = Inlet
- L1, L2 = Case drain
- M2 = System pressure gauge port
- M4 = Servo pressure gauge port
- X = LS signal port

INPUT SHAFTS

Shaft data

Code	Description	Maximum torque rating ¹ N·m [lbf·in]	Drawing
S1	14 tooth spline 12/24 pitch (ANSI B92.1 1970 - Class 5)	734 [6500]	
S2	17 tooth spline 12/24 pitch (ANSI B92.1 1970 - Class 5)	1017 [9000]	
K4	Ø 31.75 mm [1.25 in] Straight keyed	734 [6495]	

1. See *Input shaft torque ratings*, page 18 for an explanation of maximum torque.

AUXILIARY MOUNTING PADS

See page 18 for mating pump pilot and spline dimensions.

SAE-A auxiliary mounting pad
 Dimensions

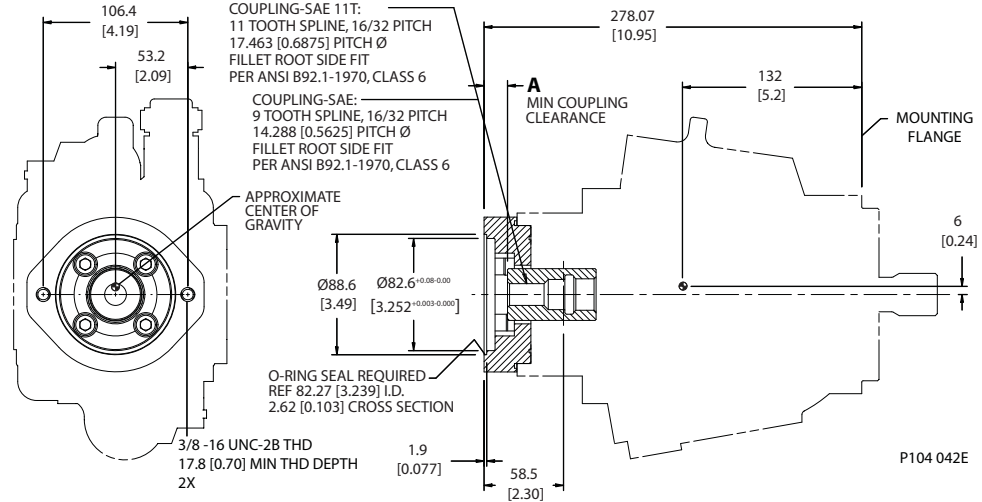

Specifications

Coupling	9-tooth	11-tooth
Spline minimum engagement	13.5 mm [0.53 in]	15 mm [0.59 in]
Maximum torque	107 N·m [950 lbf·in]	147 N·m [1300 lbf·in]
Dimension A	21.1 mm [0.83 in]	16.1 mm [0.63 in]

SAE-B auxiliary mounting pad
 Dimensions

See page 18 for mating pump pilot and spline dimensions.

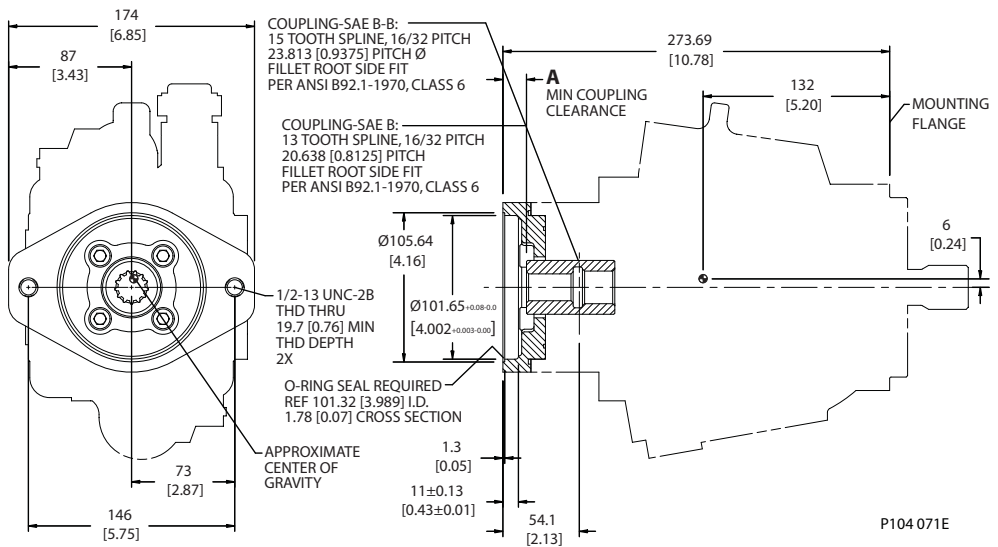

Specifications

Coupling	13-tooth	15-tooth
Spline minimum engagement	14.2 mm [0.56 in]	18.9 mm [0.74 in]
Maximum torque	249 N·m [2200 lbf·in]	339 N·m [3000 lbf·in]
Dimension A	20.7 mm [0.81 in]	12.7 mm [0.5 in]

AUXILIARY MOUNTING PADS (continued)

See page 18 for mating pump pilot and spline dimensions.

SAE-C auxiliary mounting pad
 Dimensions

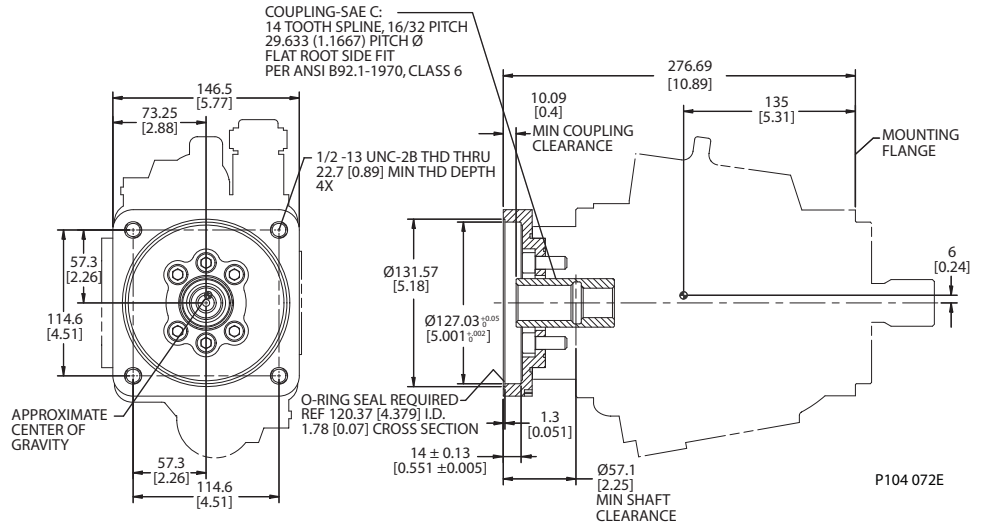

Specifications

Coupling	14-tooth
Spline minimum engagement	18.3 mm [0.72 in]
Maximum torque	339 N•m [3000 lbf•in]

DISPLACEMENT LIMITER

G Frame open circuit pumps are available with an optional adjustable displacement limiter. This adjustable stop limits the pump's maximum displacement.

Displacement limiter cross-section

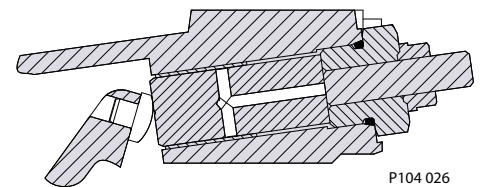

Setting range

G74B	56 to 74 cm ³ [3.39 to 4.52 in ³]
G90C	68 to 90 cm ³ [4.12 to 5.49 in ³]

INSTALLATION DRAWINGS

Running cover
 Dimensions

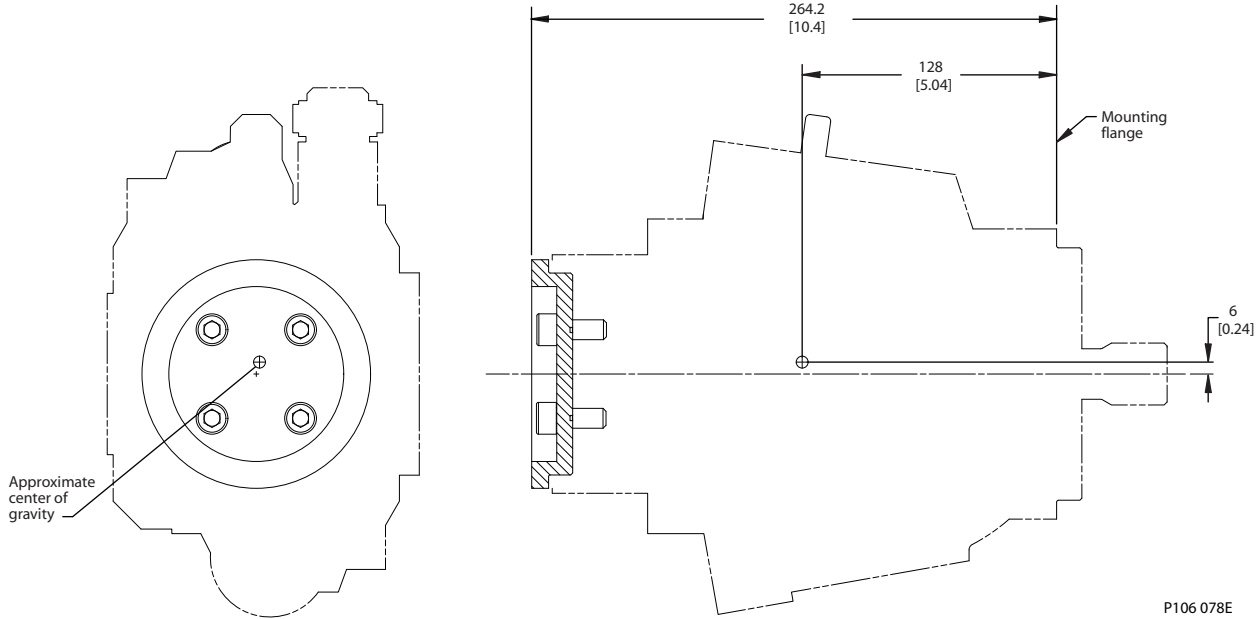

Adjustable displacement limiter
 Dimensions

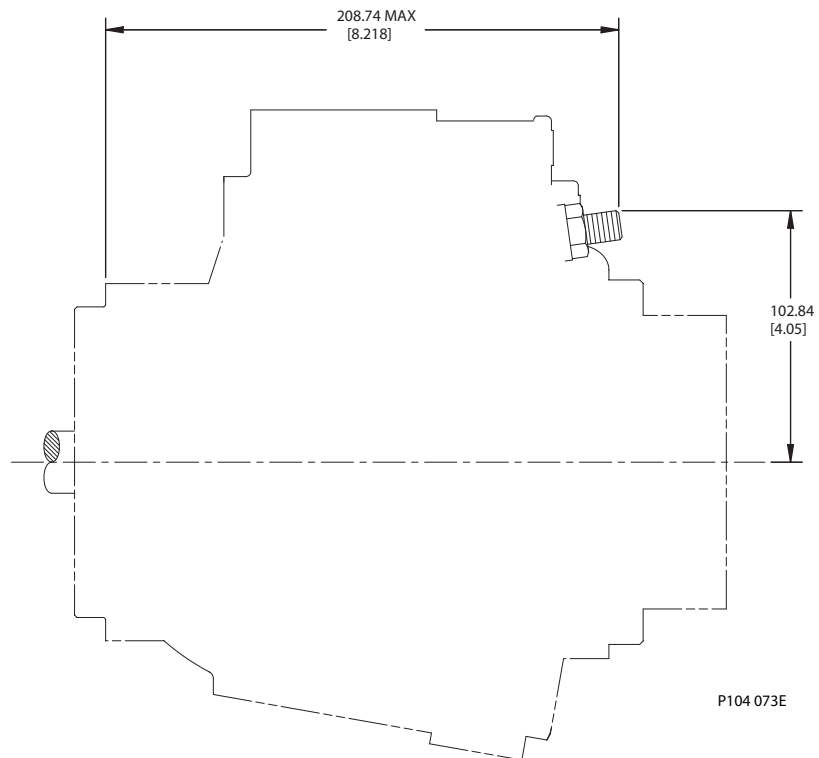

**INSTALLATION
 DRAWINGS
 (continued)**

Axial ported endcap

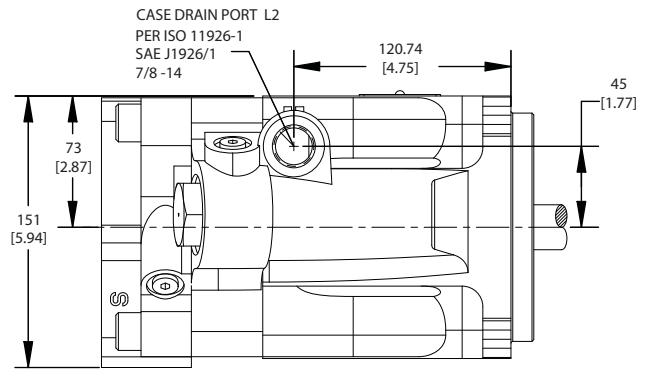
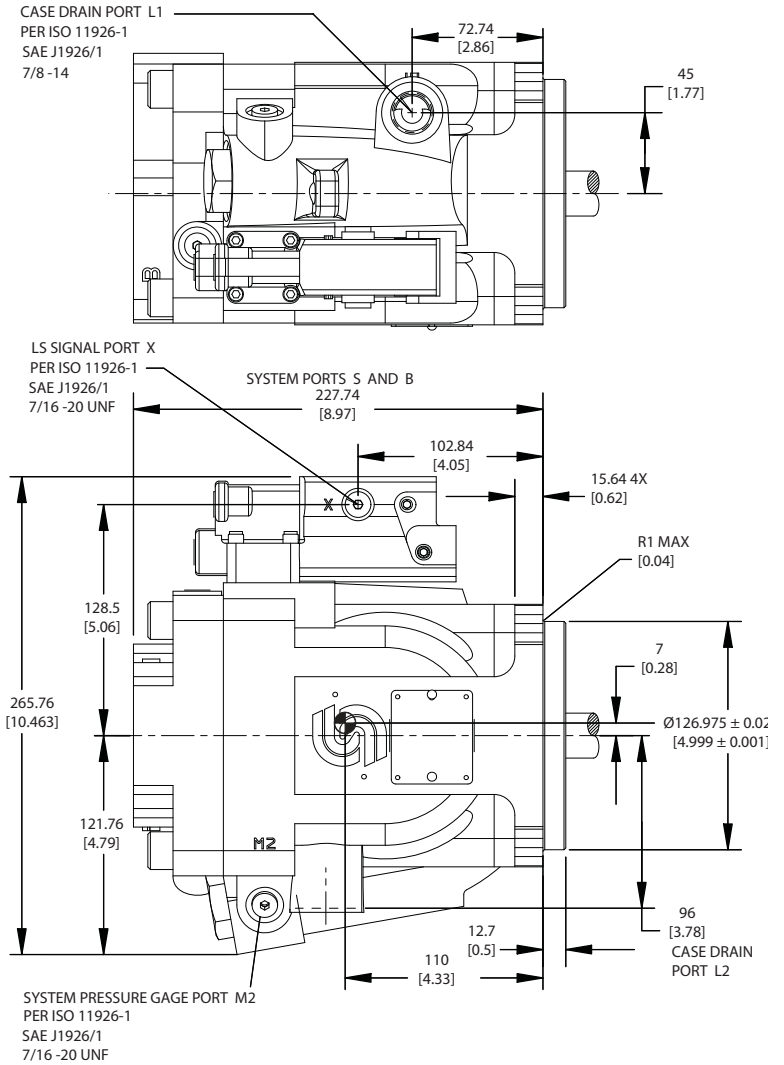
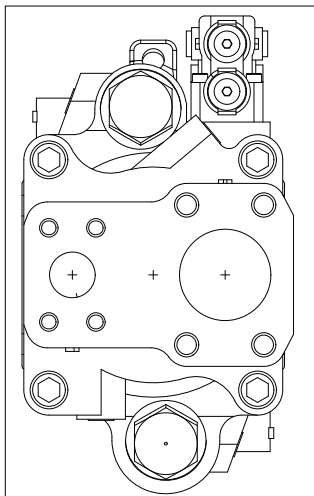
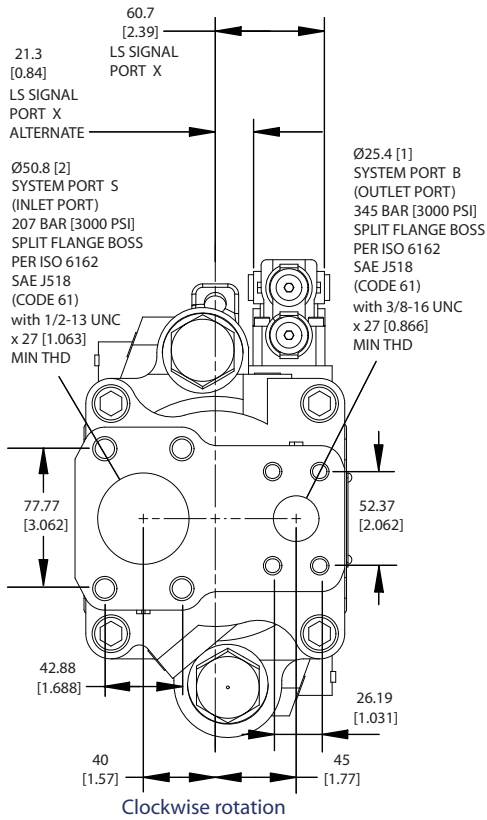

P106 174E



**INSTALLATION
DRAWINGS
(continued)**

Axial ported endcap (continued)

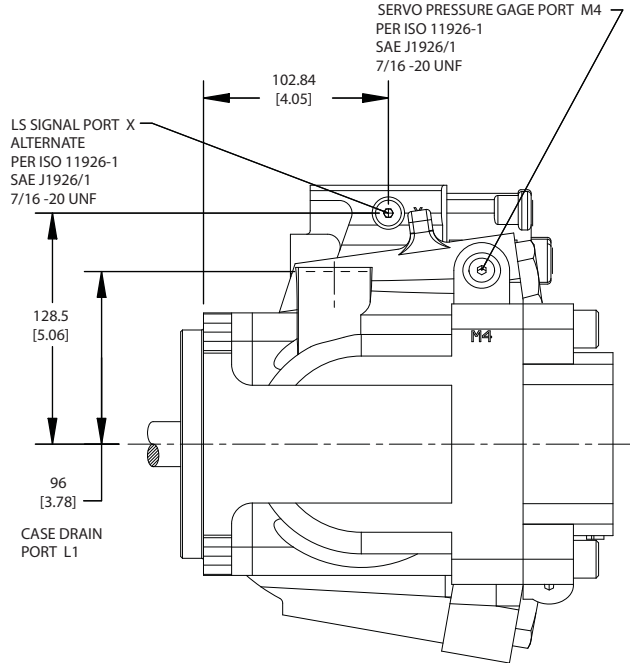
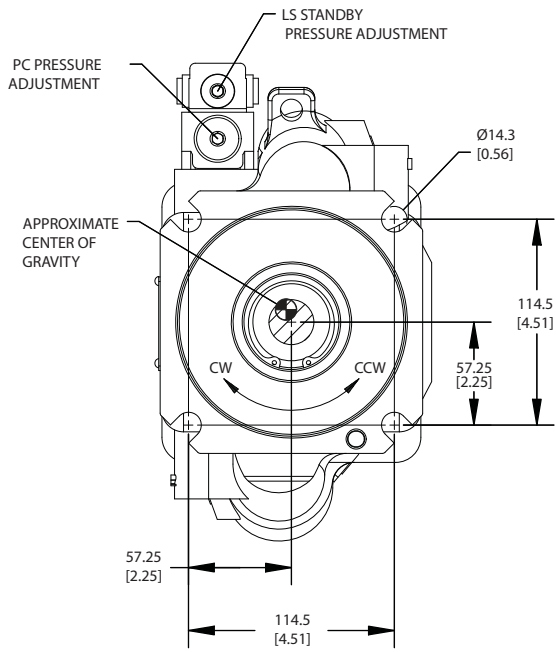

P104 074E



**INSTALLATION
 DRAWINGS
 (continued)**

Radial ported endcap

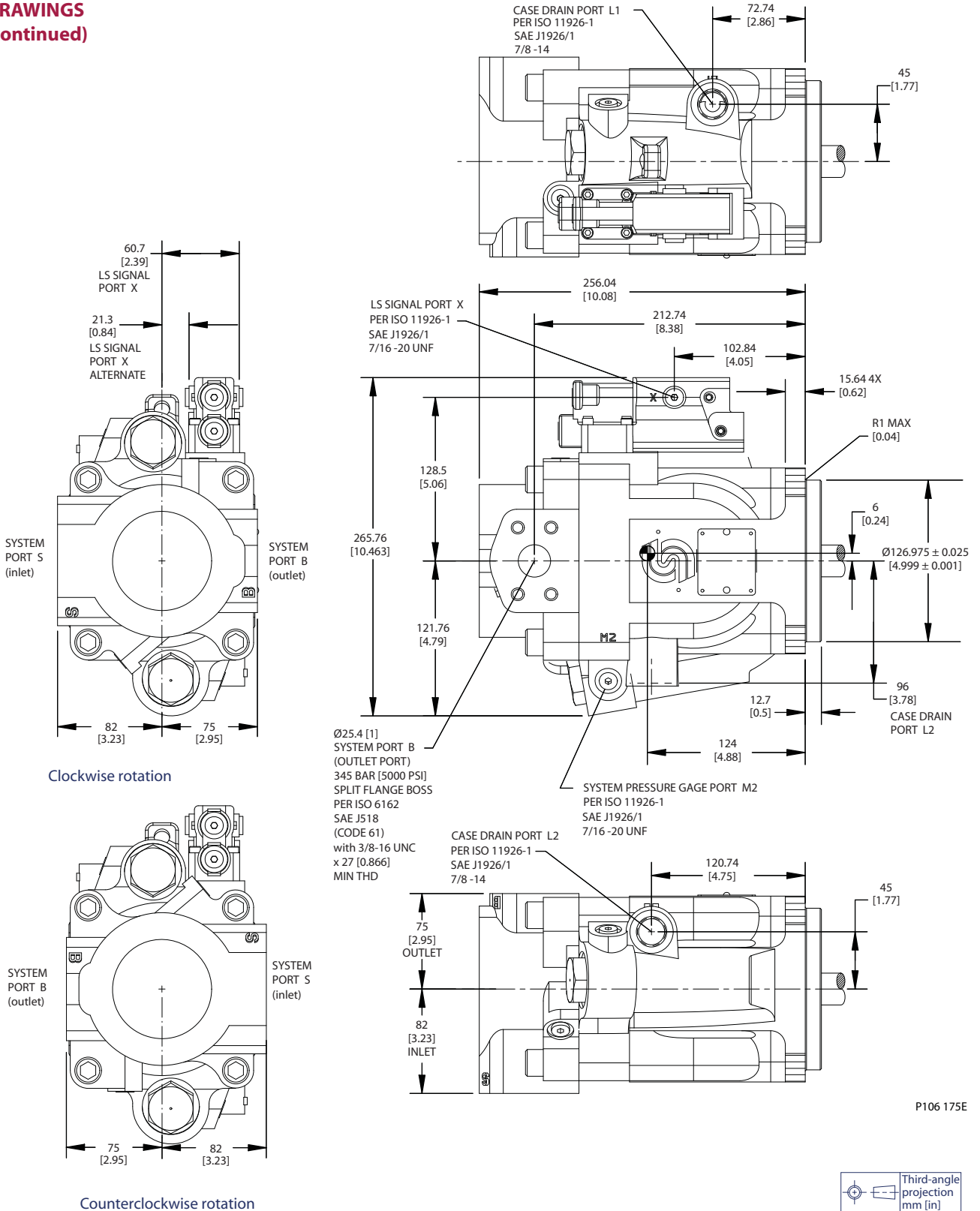

P106 175E

**INSTALLATION
DRAWINGS
(continued)**

Radial ported endcap (continued)

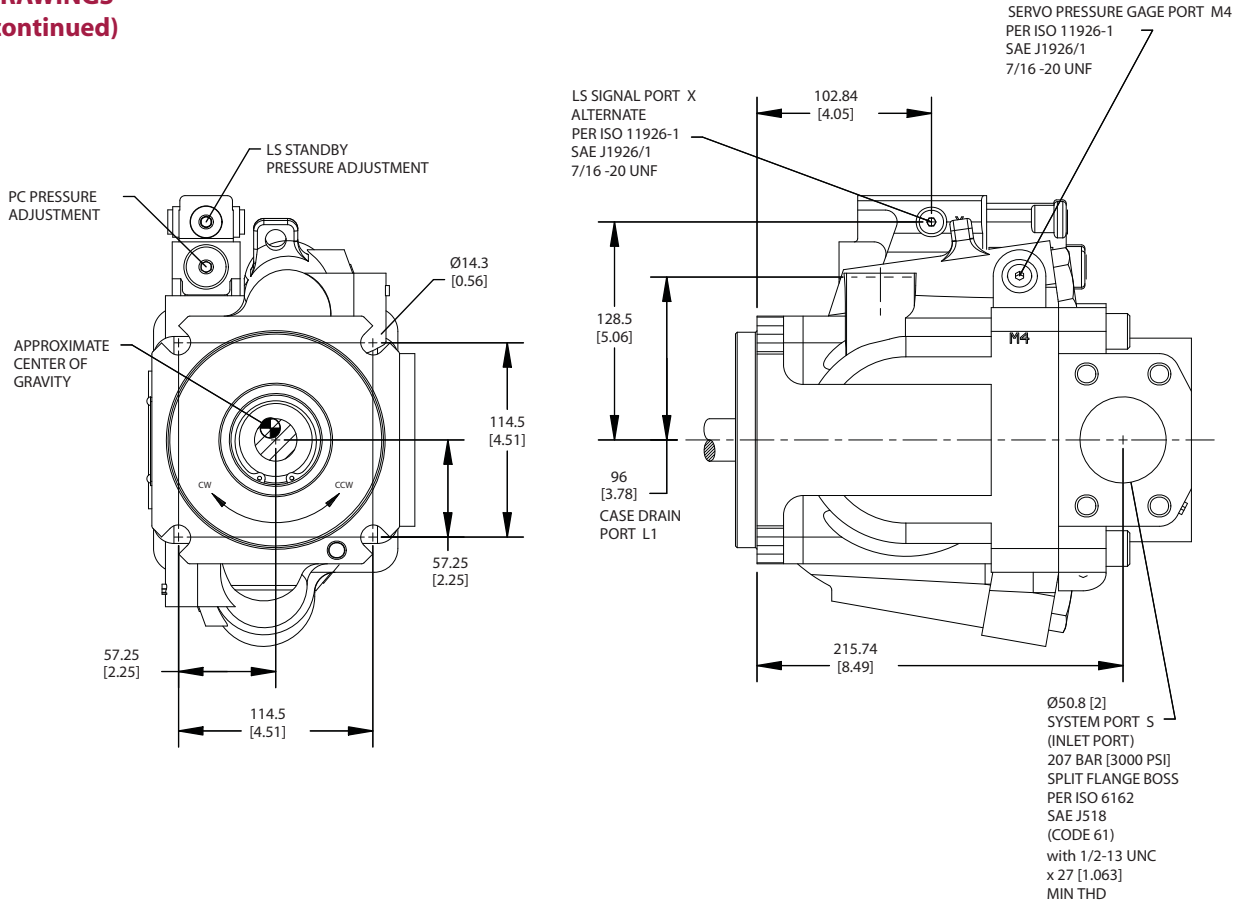

P104 075E



DESIGN

Series 45 Frame E pumps have a dual servo piston design with a cradle-type swashplate set in polymer-coated journal bearings. The bias piston increases swashplate angle. The displacement piston decreases swashplate angle. At equal pressure, the larger diameter displacement piston overpowers the bias piston. Nine reciprocating pistons displace fluid from the pump inlet to the pump outlet as the cylinder block rotates on the pump input shaft. The block spring holds the piston slippers to the swashplate via the slipper retainer. The cylinder block rides on a bi-metal valve plate optimized for high volumetric efficiency and low noise. Tapered roller bearings support the input shaft and a viton lip-seal protects against shaft leaks.

An adjustable one spool (PC only, not shown) or two spool (LS) control senses system pressure and load pressure (LS controls). The control ports system pressure to the displacement piston to control pump output flow.

Frame E cross section

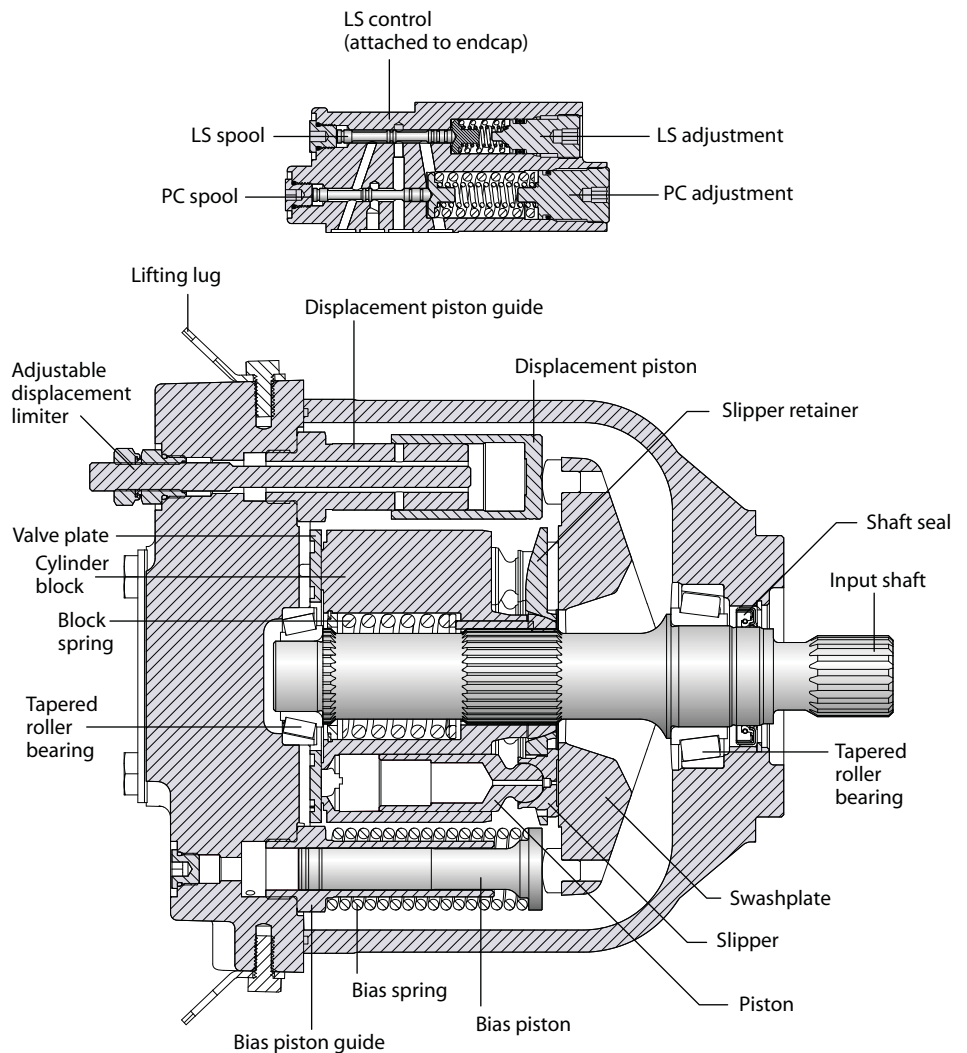

P104 001E

SPECIFICATIONS

For general operating parameters, including fluid viscosity, temperature, and inlet and case pressures, *see page 13*. For system design parameters, including installation, filtration, reservoir, and line velocities, *see page 15*.

Features and options

Feature		Unit	Model		
			E100B	E130B	E147C
Maximum Displacement		cm ³ [in ³]	100 [6.10]	130 [7.93]	147 [8.97]
Flow at rated speed (theoretical)		l/min [US gal/min]	245 [64.7]	286 [75.6]	309 [81.6]
Input torque at maximum displacement (theoretical)		N•m/bar [lbf•in/1000 psi]	1.592 [972]	2.069 [1263]	2.340 [1428]
Mass moment of inertia of internal rotating components		kg•m ² [slug•ft ²]	0.0128 [0.0094]	0.0128 [0.0094]	0.0128 [0.0094]
Weight	Axial ports	kg [lb]	51.3 [113]		
	Radial ports				
Rotation			Clockwise, Counterclockwise		
Mounting			SAE-C		
Auxiliary mounting (<i>See page 92</i>)			SAE-A, SAE-B, SAE-BB, SAE-C, SAE-CC		
System ports (type)			4-bolt split flange		
System ports (location)			Axial, Radial		
Control types (<i>See page 88</i>)			PC, Remote PC, LS, LS with internal bleed		
Shafts (<i>See page 90</i>)	Splined		13-tooth, 14-tooth, 17-tooth		
	Straight		Ø 38.08 mm [1.5 in]		
Displacement limiters (<i>See page 94</i>)			Optional, adjustable		

Ratings

Rating			Units	Model		
				E100B	E130B	E147C
Input speed ¹	minimum	min ⁻¹ (rpm)	500	500	500	
	continuous		2450	2200	2100	
	maximum		2880	2600	2475	
Working pressure	continuous	bar [psi]	310 [4495]	310 [4495]	260 [3770]	
	maximum		400 [5800]	400 [5800]	350 [5075]	
External shaft loads	External moment (M _e)	N•m [lbf•in]	455 [4030]	360 [3190]	396 [3500]	
	Thrust in (T _{in}), out (T _{out})		N [lbf]	2846 [640]	1735 [390]	2113 [475]
	Thrust out (T _{out})			7740 [1740]	6672 [1500]	7117 [1600]
Bearing life	at 140 bar [2030 psi]	B ₁₀ hours	77 200	32 700	21 600	
	at 210 bar [3045 psi]		19 800	8400	5500	
	at 260 bar [3770 psi]		9700	4116	2700	
	at 310 bar [4495 psi]		5400	2300	—	
Mounting flange load moments	Vibratory (continuous)	N•m [lbf•in]	1920 [17 000]			
	Shock (max)		6779 [60 000]			

1. Input speeds are valid at 1 bar absolute [0 in Hg vac] inlet pressure. See *Inlet pressure vs. speed* charts.

Sound levels²

For more information on noise levels, *see page 19*.

dB(A)	210 bar [3045 psi]		260 bar [3770 psi]		310 bar [4495 psi]		
	Model	1800 min ⁻¹ (rpm)	Rated speed	1800 min ⁻¹ (rpm)	Rated speed	1800 min ⁻¹ (rpm)	Rated speed
E100B		75	77	77	78	77	80
E130B		77	81	78	81	78	81
E147C		77	78	78	78	—	—

2. Sound data was collected in a *semi-anechoic* chamber. Values have been adjusted (-3 dB) to reflect *anechoic* levels.

PERFORMANCE
E100B

Flow and power data valid at 49°C [120°F] and viscosity of 17.8 mm²/sec [88 SUS].

Flow vs. speed

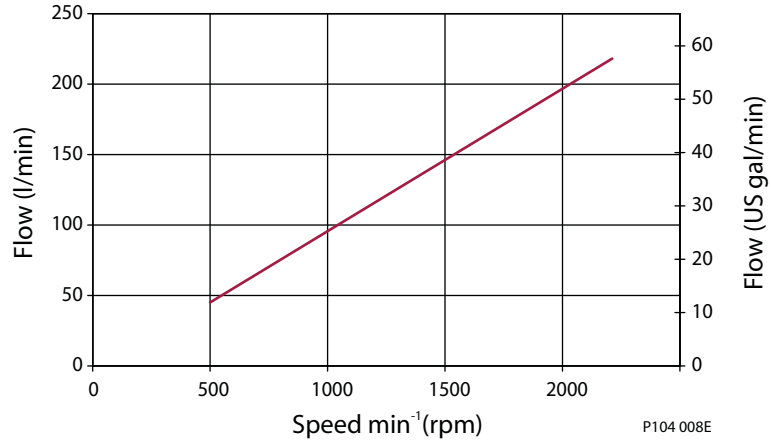

Input power vs. speed

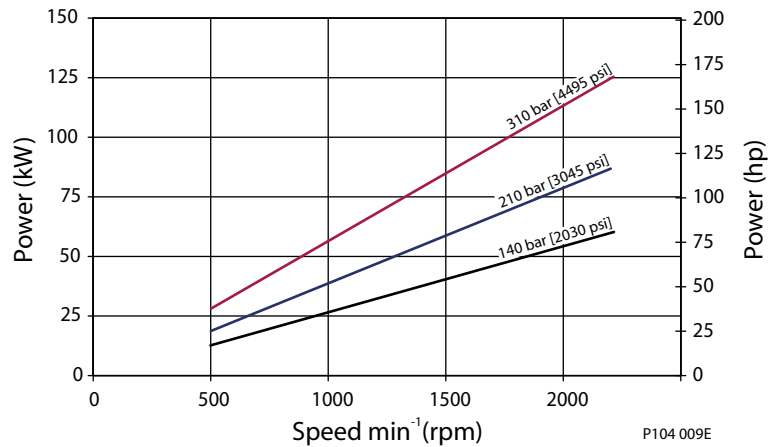

Inlet pressure vs. speed

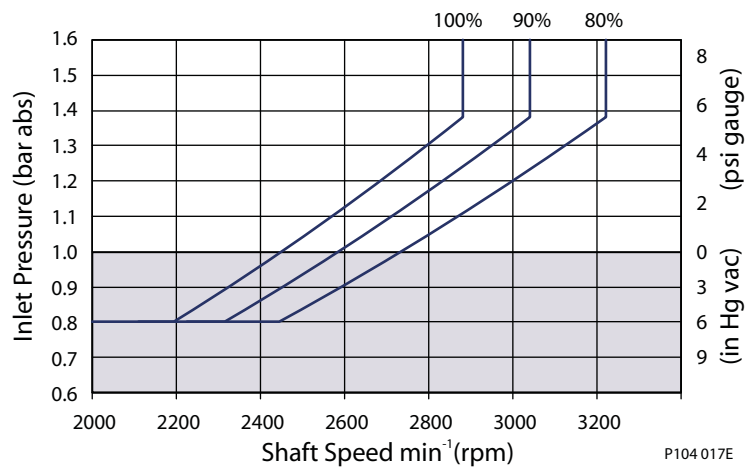

The chart on the right shows allowable inlet pressure and speed at various displacements. Greater speeds and lower inlet pressures are possible at reduced displacement. Operating outside of acceptable limits reduces pump life.

PERFORMANCE
E130B

Flow and power data valid at 49°C [120°F] and viscosity of 17.8 mm²/sec [88 SUS].

Flow vs. speed

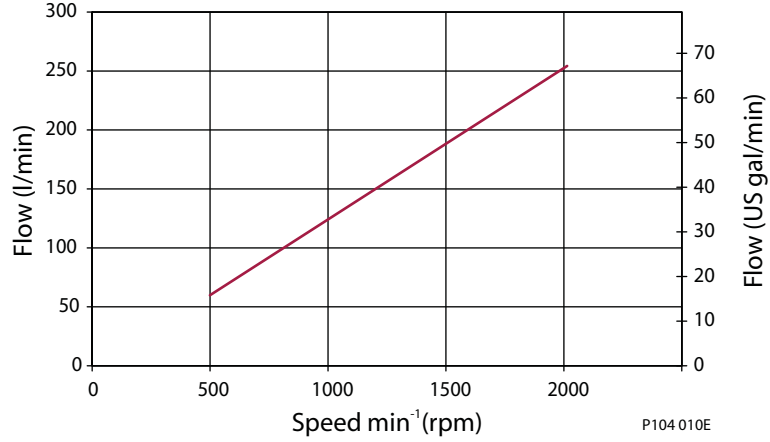

Input power vs. speed

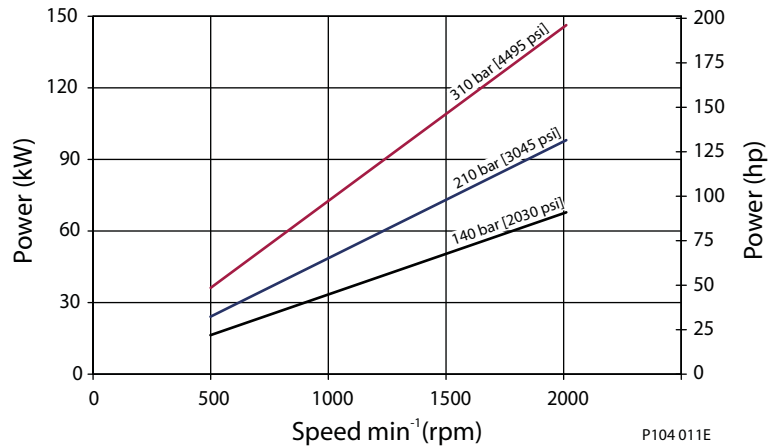

Inlet pressure vs. speed

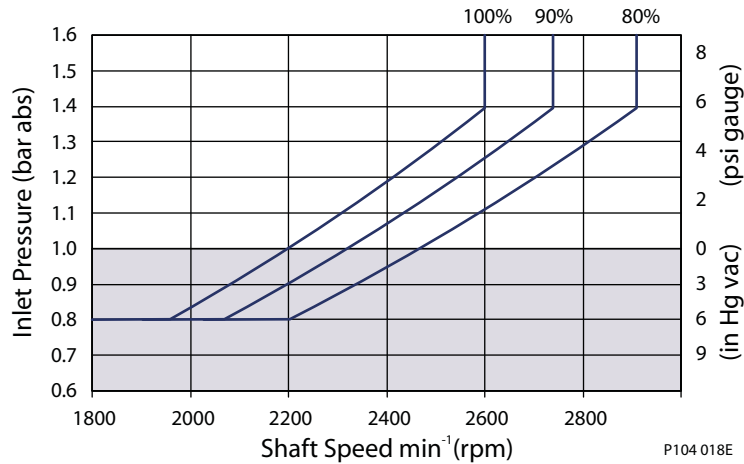

The chart on the right shows allowable inlet pressure and speed at various displacements. Greater speeds and lower inlet pressures are possible at reduced displacement. Operating outside of acceptable limits reduces pump life.

PERFORMANCE
E147C

Flow and power data valid at 49°C [120°F] and viscosity of 17.8 mm²/sec [88 SUS].

Flow vs. speed

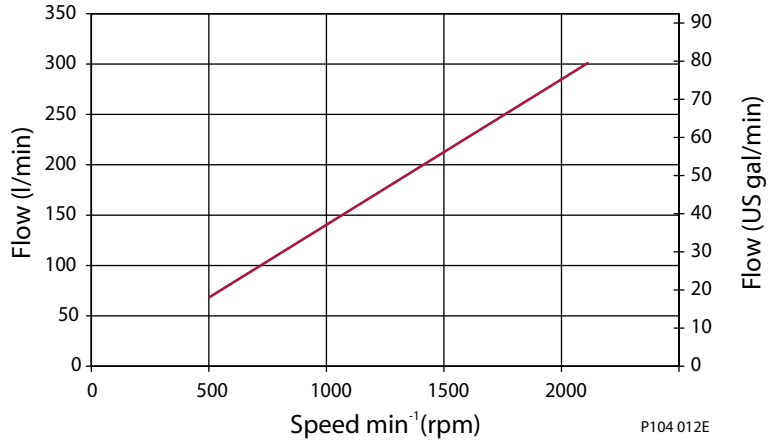

Input power vs. speed

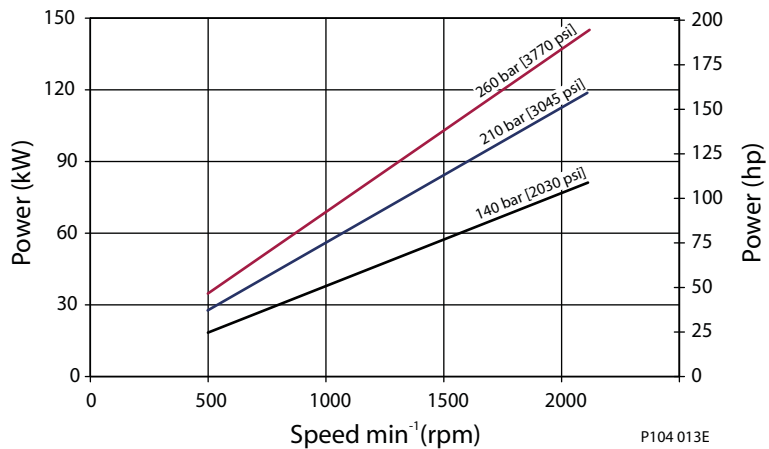

Inlet pressure vs. speed

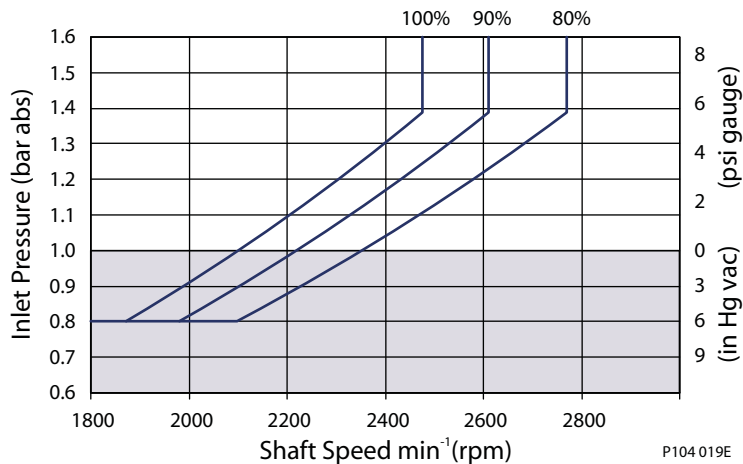

The chart on the right shows allowable inlet pressure and speed at various displacements. Greater speeds and lower inlet pressures are possible at reduced displacement. Operating outside of acceptable limits reduces pump life.

ORDER CODE



R Product

ER	E Frame, variable displacement open circuit pump
-----------	--

S Rotation

L	Left hand (counterclockwise)
R	Right hand (clockwise)

P Displacement and pressure rating

100B	100 cm ³ /rev [6.10 in ³ /rev], 310 bar [4495 psi] continuous working pressure
130B	130 cm ³ /rev [7.93 in ³ /rev], 310 bar [4495 psi] continuous working pressure
147C	147 cm ³ /rev [8.97 in ³ /rev], 260 bar [3770 psi] continuous working pressure

C Control type

PC	Pressure compensated control 100-280 bar [1450-4060 psi]
BC*	Pressure compensated control 290-310 bar [4205-4495 psi]
RP	Remote pressure compensated control 100-280 bar [1450-4060 psi]
BP*	Remote pressure compensated control 290-310 bar [4205-4495 psi]
LS	Load sensing / pressure compensating control 100-280 bar [1450-4060 psi]
BS*	Load sensing / pressure compensating control 290-310 bar [4205-4495 psi]
LB	Load sensing / pressure compensating control with internal bleed orifice 100-280 bar [1450-4060 psi]
BB*	Load sensing / pressure compensating control with internal bleed orifice 290-310 bar [4205-4495 psi]

* Use only with 100, and 130 cm³ displacements.

D PC setting (2 digit code, 10 bar increments)

Example	10 = 100 bar
10-31	100 to 310 bar [1450 to 4495 psi] (100B, 130B)
10-26	100 to 260 bar [1450 to 3770 psi] (147C)

E Load sensing setting (2 digit code, 1 bar increments)

Example	20 = 20 bar
10-30	10 to 30 bar [145 to 435 psi]
NN	Not applicable (use with PC controls)

F Not used

NN	Not applicable
-----------	----------------

ORDER CODE
 (continued)



G Pilot orifice

N	None (standard)
----------	-----------------

H Gain orifice

3	Standard orifice
----------	------------------

J1 Input shaft

S1	14-tooth, 12/24 pitch (ANSI B92.1 1970 - Class 5)
S2	17-tooth, 12/24 pitch (ANSI B92.1 1970 - Class 5)
S4	13-tooth, 8/16 pitch (ANSI B92.1 1970 - Class 5)
K5	Ø 38.08 mm [1.5 in], straight keyed
S5	14-tooth spline 12/24 pitch (ANSI B92.1 1970 - Class 5)

J2 Auxiliary mounting flange

N	None
A	SAE-A, 9-tooth coupling
T	SAE-A, 11-tooth coupling
B	SAE-B, 13-tooth coupling
V	SAE-BB, 15-tooth coupling
C	SAE-C, 14-tooth coupling
W	SAE-CC, 17-tooth coupling

J3 System port size and location

Code	Location	Port type	Inlet size	Outlet size
P	Radial	4-bolt split-flange	2 ½ in.	1 ¼ in.
L	Axial	4-bolt split-flange	2 ½ in.	1 ¼ in.

K1 Shaft seal

A	Single lip seal, viton
----------	------------------------

K2 Mounting flange and housing port style

1	SAE-C 4-bolt, SAE O-ring boss housing ports
----------	---

K3 Not used

N	Not applicable
----------	----------------

L Displacement limiter

NNN	None
AAA	Adjustable, factory set at max angle

M Special hardware

NNN	None
------------	------

N Special features

NNN	None
------------	------

CONTROLS

Pressure compensated control (PC)

Specifications *PC control setting range*

Model	bar	psi
E100B	100–310	1450–4495
E130B	100–310	1450–4495
E147C	100–260	1450–3770

*Response/recovery times**

(ms)	Response	Recovery
E100B	45	175
E130B	55	175
E147C	60	190

* For definitions, see page 9.

Schematic diagram *PC schematic*

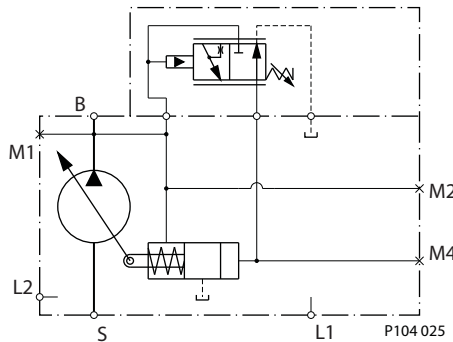

Legend

- B = Outlet
- S = Inlet
- L1, L2 = Case drain
- M2 = System pressure gauge port
- M4 = Servo pressure gauge port

Remote PC control (RP)

Specifications *PC control setting range*

Model	bar	psi
E100B	100–310	1450–4495
E130B	100–310	1450–4495
E147C	100–260	1450–3770

*Response/recovery times**

(ms)	Response	Recovery
E100B	45	175
E130B	55	175
E147C	60	190

* For definitions, see page 10.

Schematic diagram *Remote PC schematic*

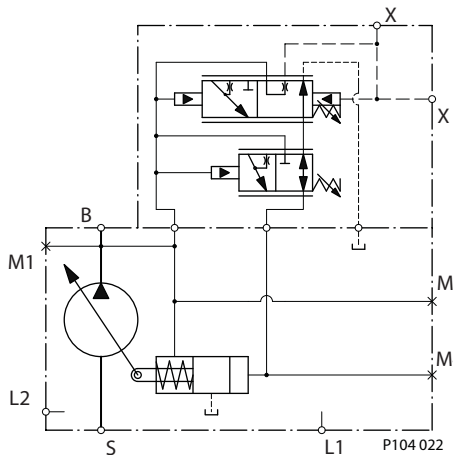

Legend

- B = Outlet
- S = Inlet
- L1, L2 = Case drain
- M2 = System pressure gauge port
- M4 = Servo pressure gauge port
- X = Remote PC port

CONTROLS
 (continued)

Load sensing control (LS)

Specifications *PC setting range*

Model	bar	psi
E100B	100–310	1450–4495
E130B	100–310	1450–4495
E147C	100–260	1450–3770

*Response/recovery times**

(ms)	Response	Recovery
E100B	45	200
E130B	50	200
E147C	60	200

* For definitions, see page 11.

Schematic diagram *LS Schematic*

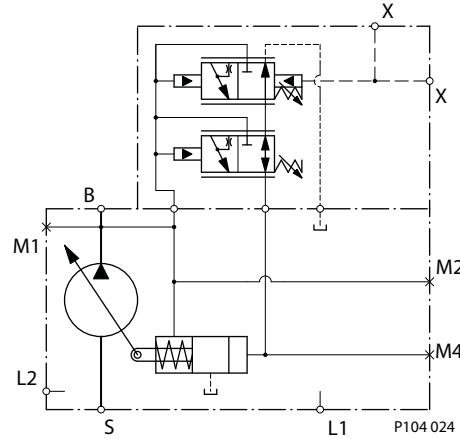

LS setting range

Model	bar	psi
All	10–30	145–435

Legend

- B = Outlet
- S = Inlet
- L1, L2 = Case drain
- M2 = System pressure gauge port
- M4 = Servo pressure gauge port
- X = LS signal port

Load sensing control with internal bleed orifice (LB)

Specifications *PC setting range*

Model	bar	psi
E100B	100–310	1450–4495
E130B	100–310	1450–4495
E147C	100–260	1450–3770

*Response/recovery times**

(ms)	Response	Recovery
E100B	45	200
E130B	50	200
E147C	60	200

* For definitions, see page 11.

Schematic diagram *LB Schematic*

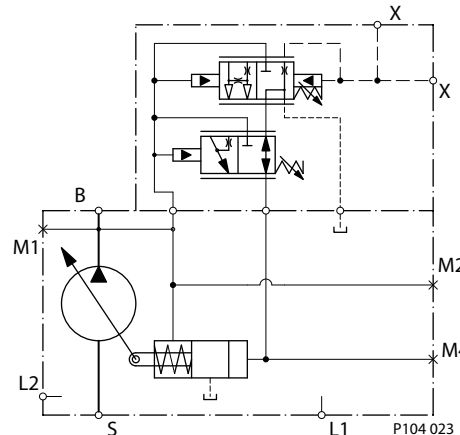

LS setting range

Model	bar	psi
All	10–30	145–435

Legend

- B = Outlet
- S = Inlet
- L1, L2 = Case drain
- M2 = System pressure gauge port
- M2 = Servo pressure gauge port
- X = LS signal port

INPUT SHAFTS

Shaft data

Code	Description	Maximum torque rating ¹ N·m [lbf·in]	Drawing
S1	14-tooth spline 12/24 pitch (ANSI B92.1 1970 - Class 5)	1093 [9675]	
S2	17-tooth spline 12/24 pitch (ANSI B92.1 1970 - Class 5)	1044 [9240]	
S4	13-tooth spline 8/16 pitch (ANSI B92.1 1970 - Class 5)	1551 [13 730]	

1. See *Input shaft torque ratings*, page 18 for an explanation of maximum torque.

INPUT SHAFTS
 (continued)

Code	Description	Maximum torque rating ¹ N•m [lbf•in]	Drawing
K5	Ø 38.08 mm [1.5 in] Straight keyed	1161 [10 270]	<p>9.525 [0.375] X 38.1 [1.5] LONG SQUARE KEY</p> <p>Ø38.075 ± 0.025 [1.5 ± 0.0009]</p> <p>Ø42.26 ± 0.125 [1.664 ± 0.005]</p> <p>54 [2.13]</p> <p>8 ± 0.7 [0.31 ± 0.03]</p> <p>COUPLING MUST NOT PROTRUDE BEYOND THIS POINT</p> <p>P104 037E</p>
S5	14-tooth spline 12/24 pitch (ANSI B92.1 1970 - Class 5)	594 [5261]	<p>Ø25.52 Max [1.005]</p> <p>14 TOOTH 12/24 PITCH 30° PRESSURE ANGLE 29.634 [1.167] PITCH FILLET ROOT SIDE FIT COMPATIBLE WITH ANSI B92.1-1970 CLASS 5 ALSO MATES WITH FLAT ROOT SIDE FIT</p> <p>Ø31.14 ± 0.08 [1.226 ± 0.003]</p> <p>24 ± 0.5 [0.945 ± 0.02]</p> <p>48 [1.89]</p> <p>8 ± 0.7 [0.31 ± 0.03]</p> <p>COUPLING MUST NOT PROTRUDE BEYOND THIS POINT</p> <p>P106 062E</p>

1. See *Input shaft torque ratings*, page 18 for an explanation of maximum torque.

AUXILIARY MOUNTING PADS

See page 18 for mating pump pilot and spline dimensions.

SAE-A auxiliary mounting pad
 Dimensions

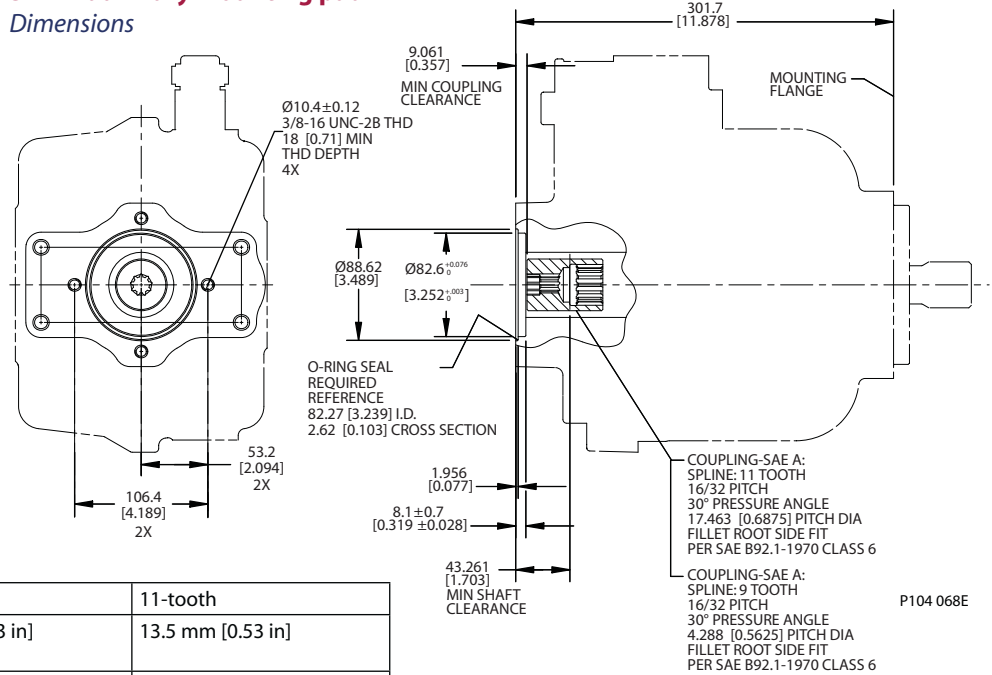

Specifications

Coupling	9-tooth	11-tooth
Spline minimum engagement	13.5 mm [0.53 in]	13.5 mm [0.53 in]
Maximum torque	107 N•m [950 lbf•in]	147 N•m [1300 lbf•in]

SAE-B auxiliary mounting pad
 Dimensions

See page 18 for mating pump pilot and spline dimensions.

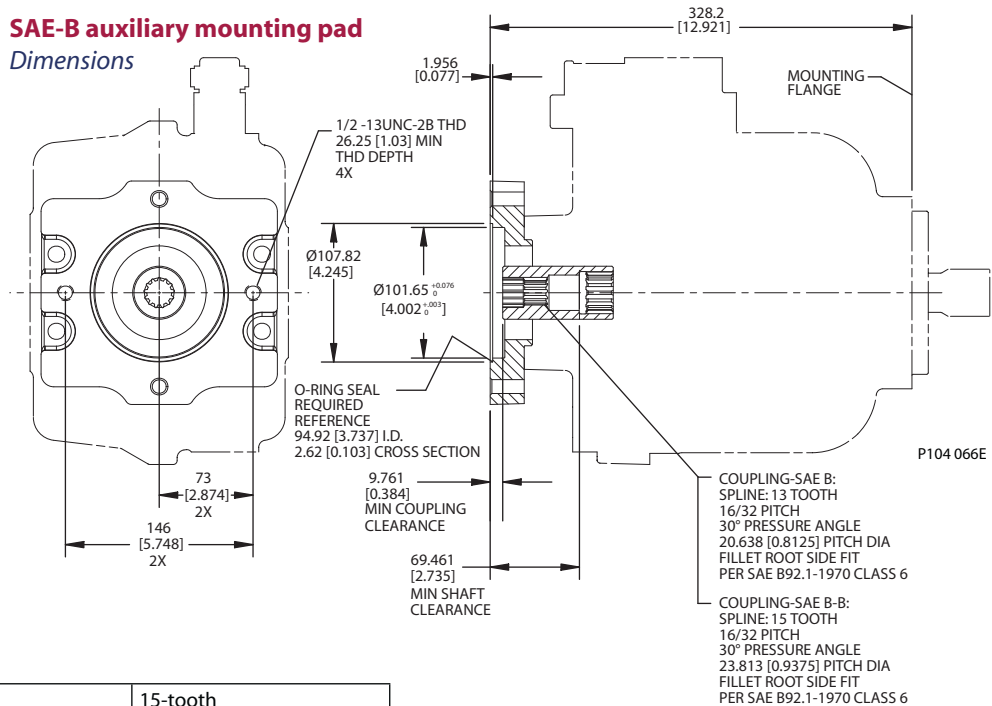

Specifications

Coupling	13-tooth	15-tooth
Spline minimum engagement	14.2 mm [0.56 in]	16.1 mm [0.63 in]
Maximum torque	249 N•m [2200 lbf•in]	339 N•m [3000 lbf•in]

AUXILIARY MOUNTING PADS (continued)

See page 18 for mating pump pilot and spline dimensions.

SAE-C auxiliary mounting pad
 Dimensions

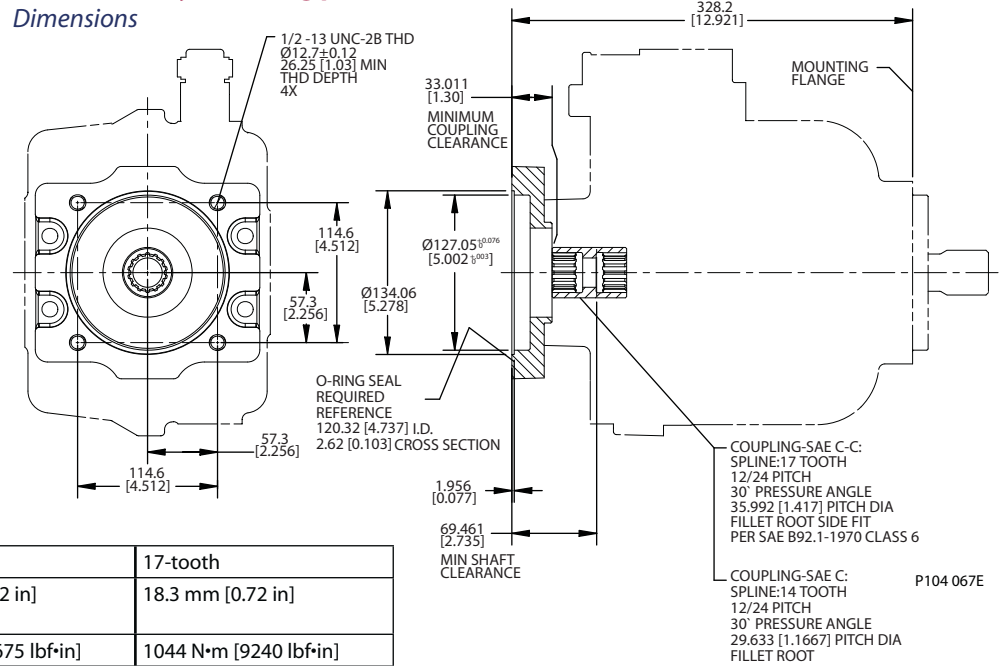

Specifications

Coupling	14-tooth	17-tooth
Spline minimum engagement	18.3 mm [0.72 in]	18.3 mm [0.72 in]
Maximum torque	1093 N·m [9675 lbf·in]	1044 N·m [9240 lbf·in]

Running cover
 Dimensions

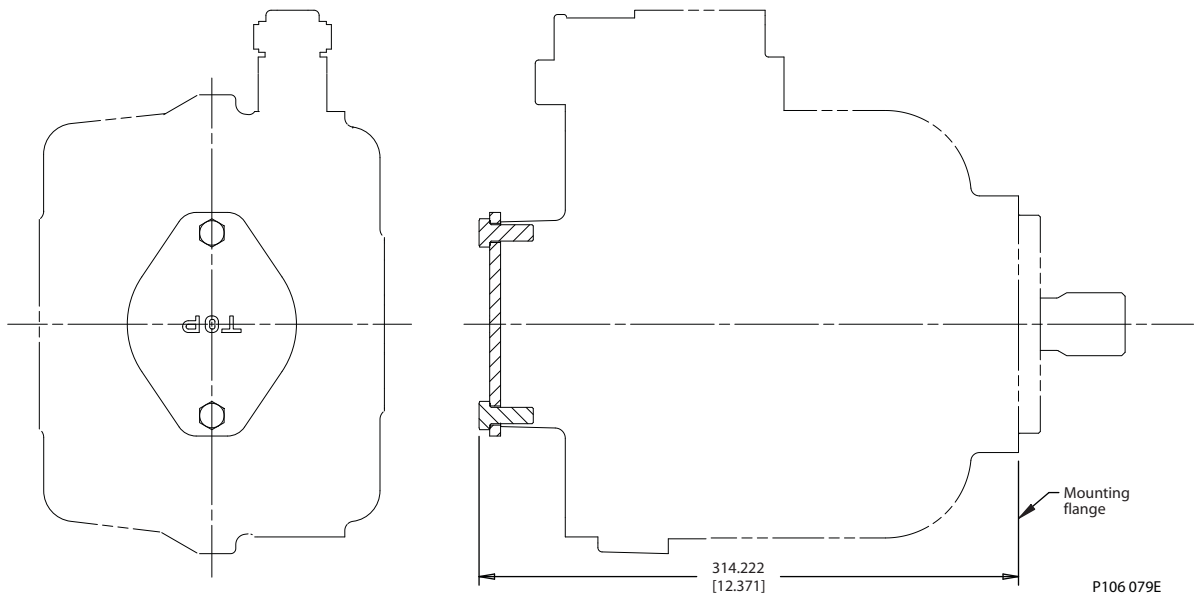

DISPLACEMENT LIMITERS

E Frame open circuit pumps are available with an optional adjustable displacement limiter. This adjustable stop limits the pump's maximum displacement.

Displacement limiter cross-section

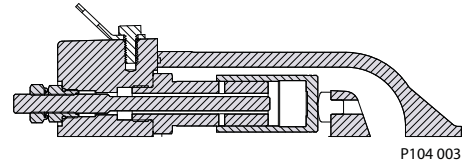

P104 003

Setting range

E100B	40 to 100 cm ³ [2.44 to 6.1 in ³]
E130B	70 to 130 cm ³ [4.27 to 7.93 in ³]
E147C	87 to 147 cm ³ [5.31 to 8.97 in ³]

**INSTALLATION
 DRAWINGS**

Axial ported endcap, clockwise rotation

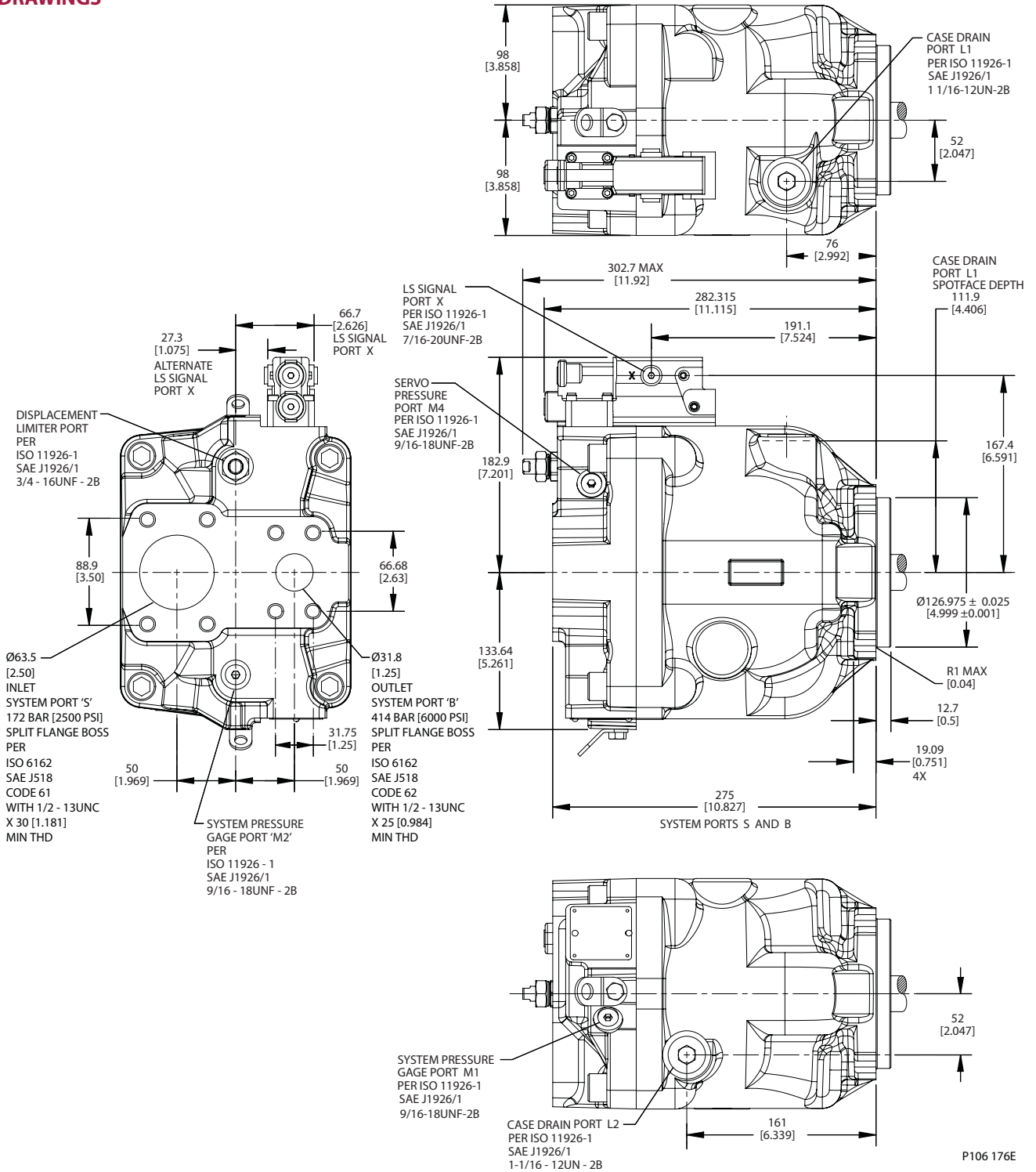

INSTALLATION DRAWINGS (continued)

Axial ported endcap, clockwise rotation (continued)

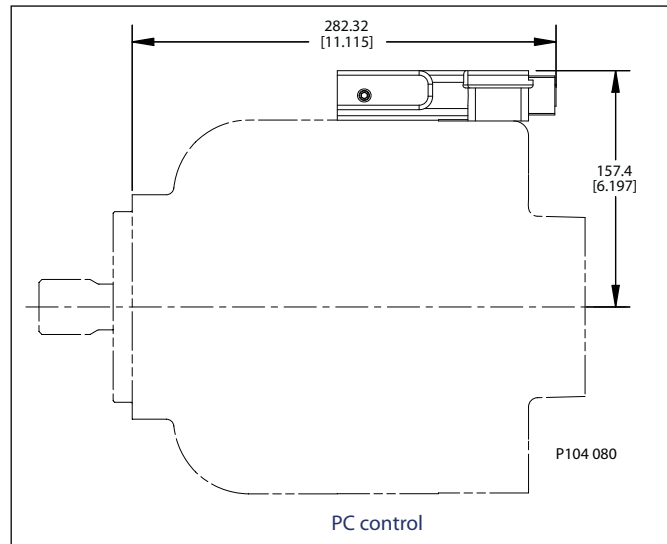
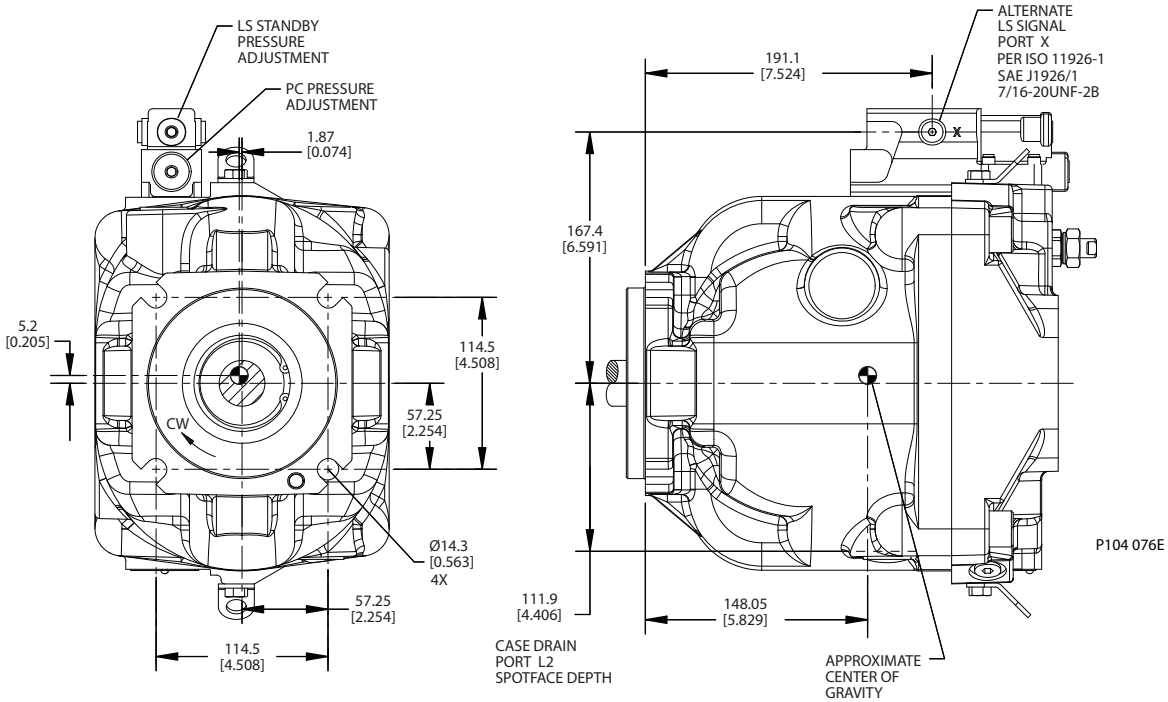

**INSTALLATION
 DRAWINGS
 (continued)**

Axial ported endcap, counterclockwise rotation

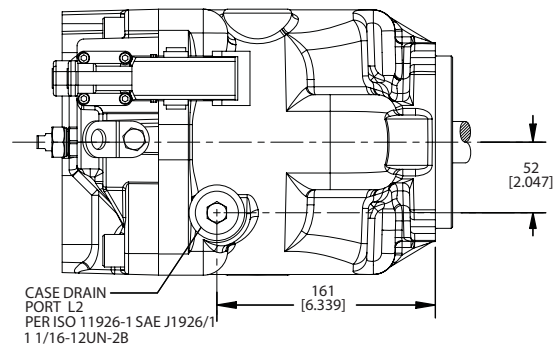
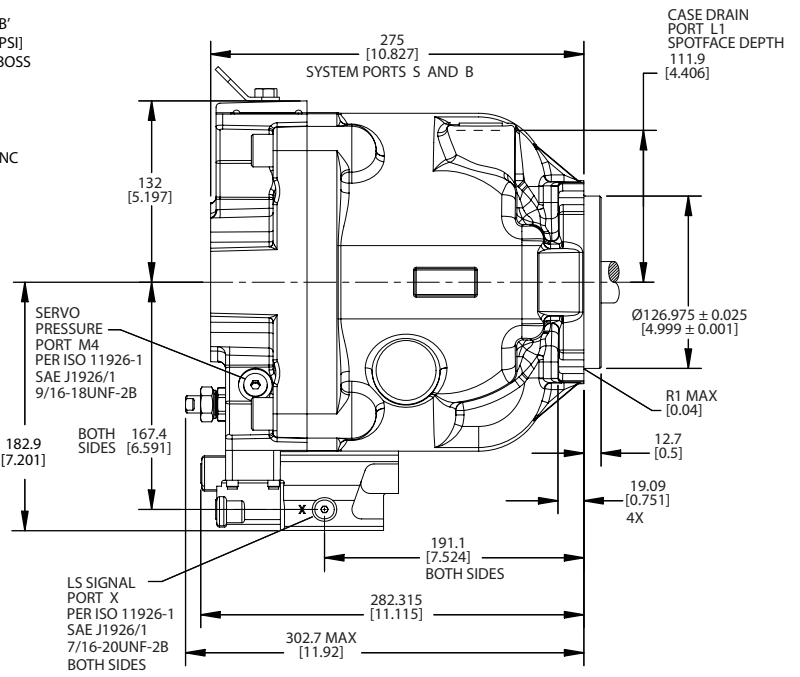
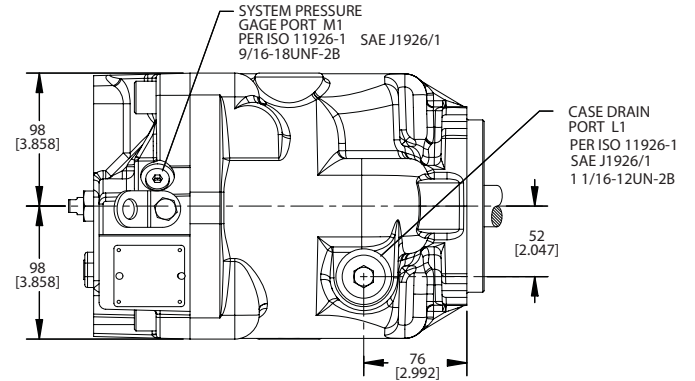
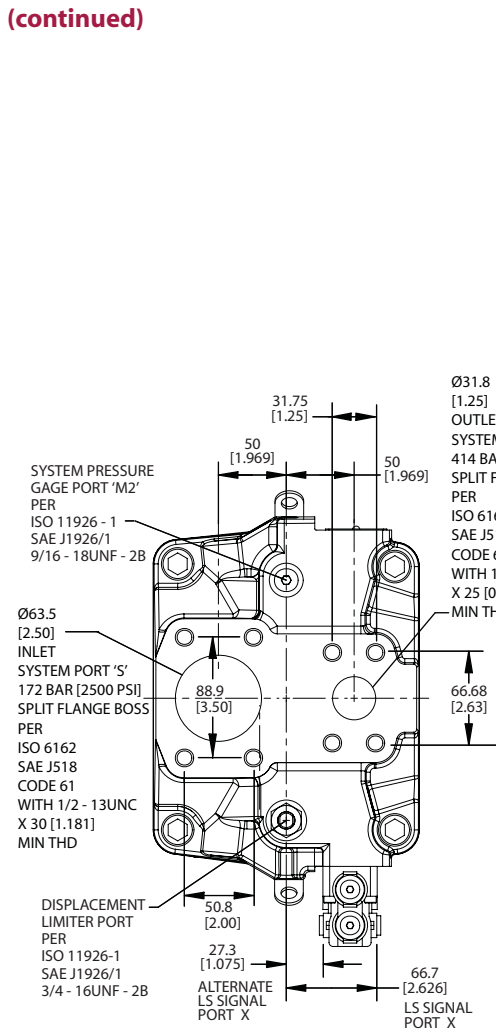

P106 177E



**INSTALLATION
DRAWINGS
(continued)**

Axial ported endcap, counterclockwise rotation (continued)

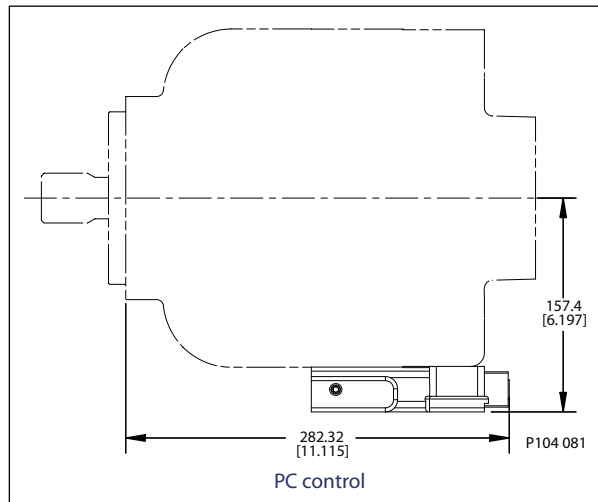
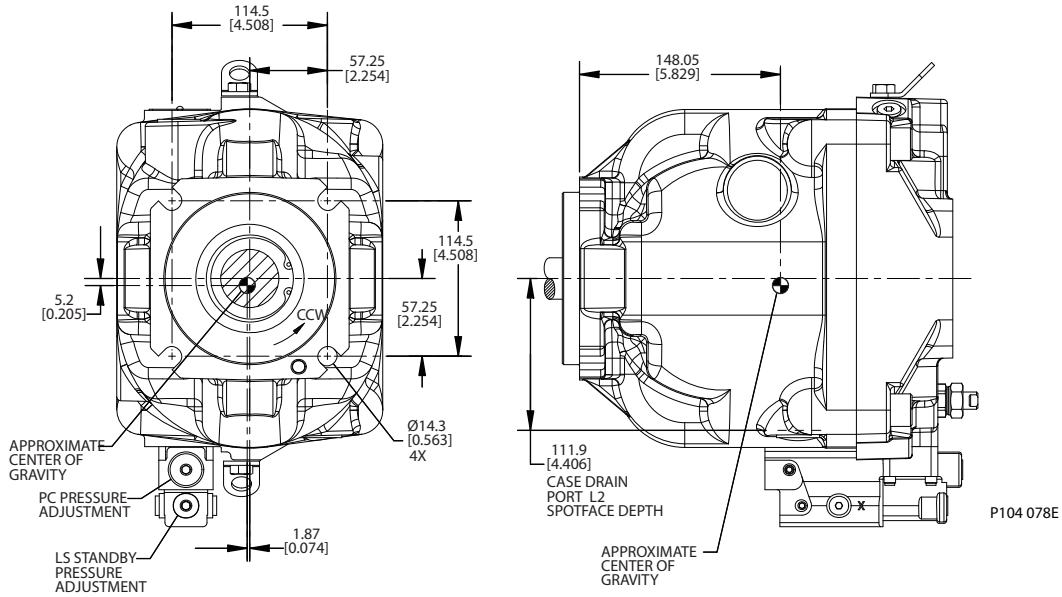

**INSTALLATION
 DRAWINGS
 (continued)**

Radial ported endcap, clockwise rotation

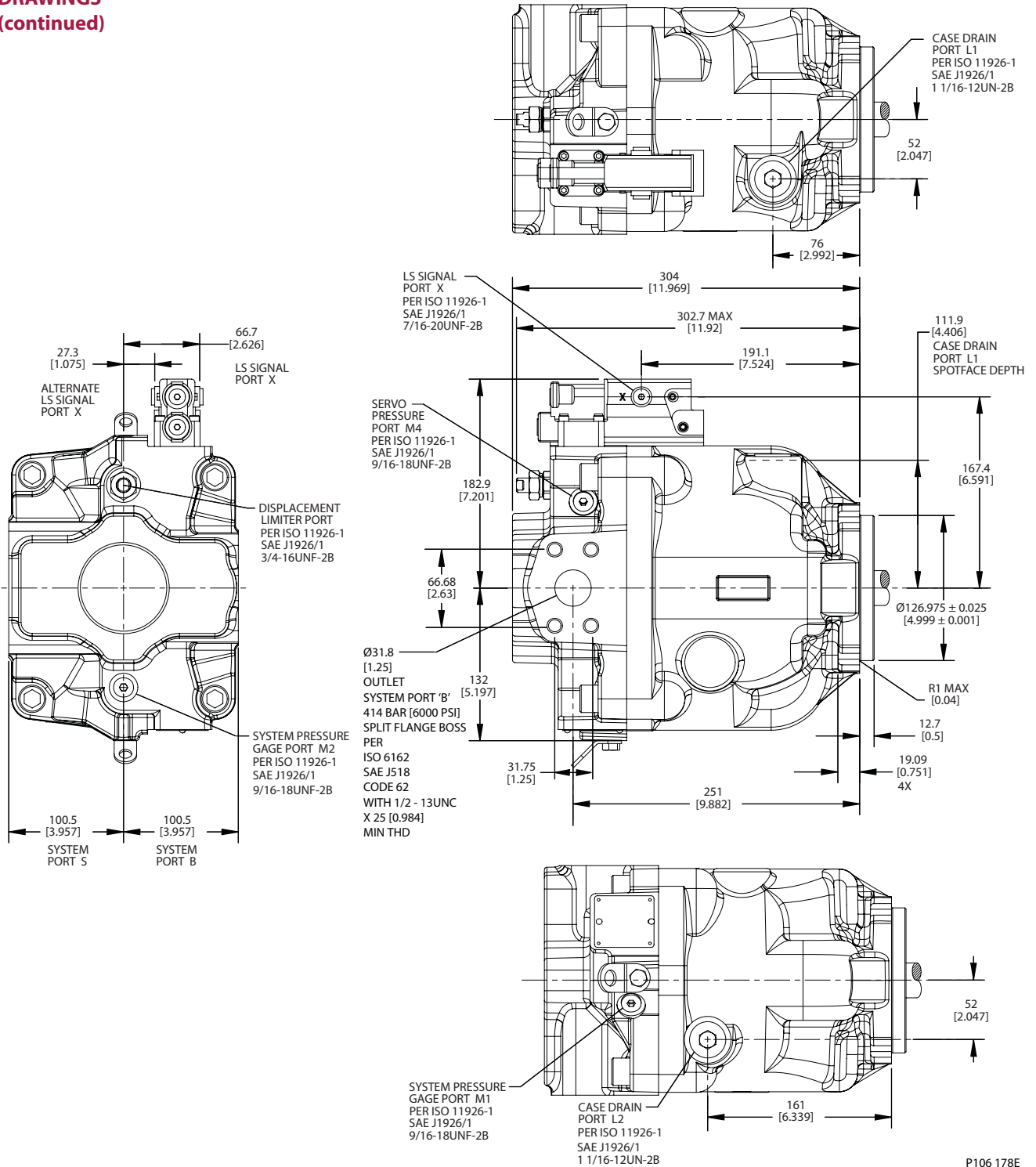

P106 178E



INSTALLATION DRAWINGS (continued)

Radial ported endcap, clockwise rotation (continued)

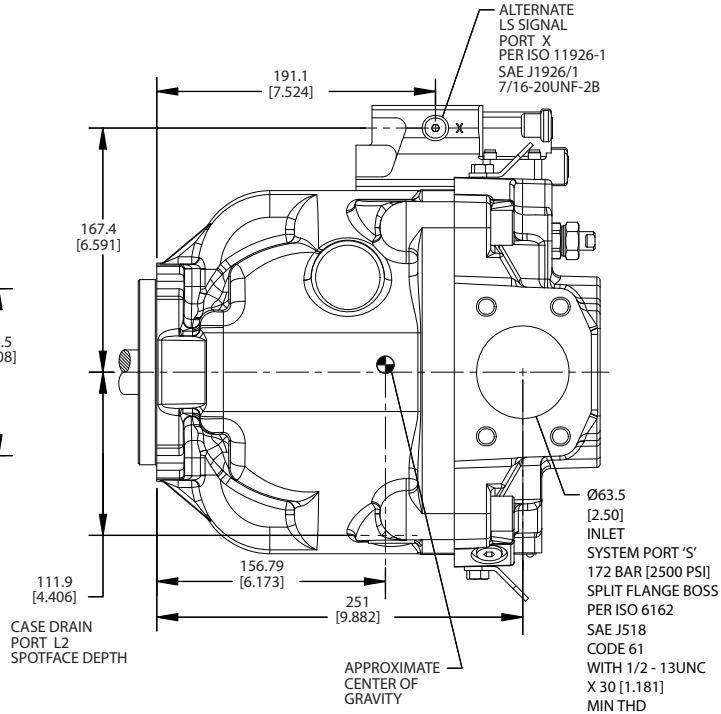
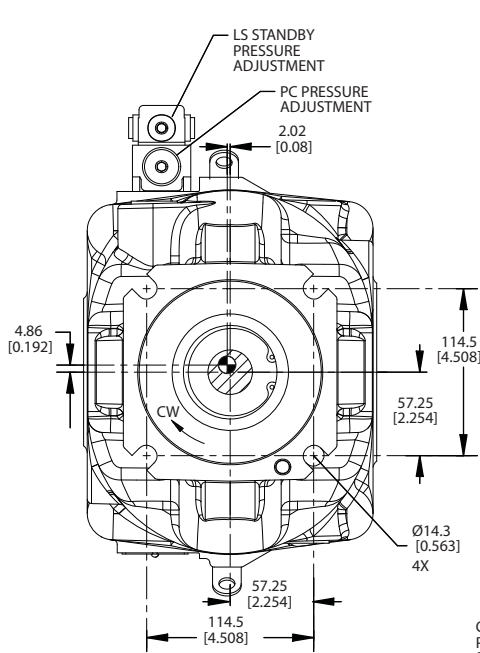

P104 077E

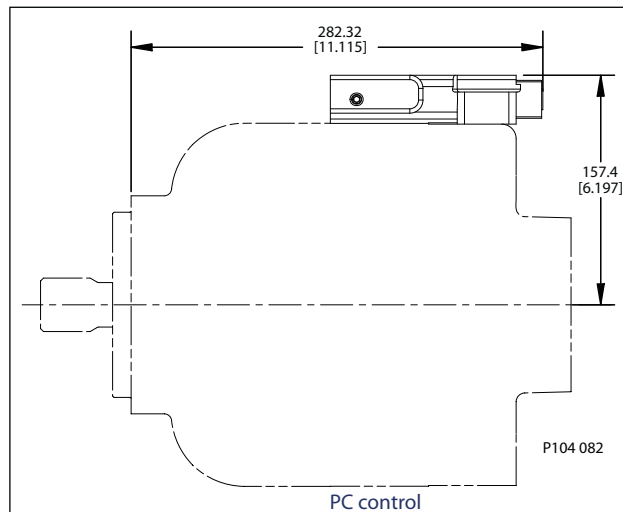

**INSTALLATION
 DRAWINGS
 (continued)**

Radial ported endcap, counterclockwise rotation

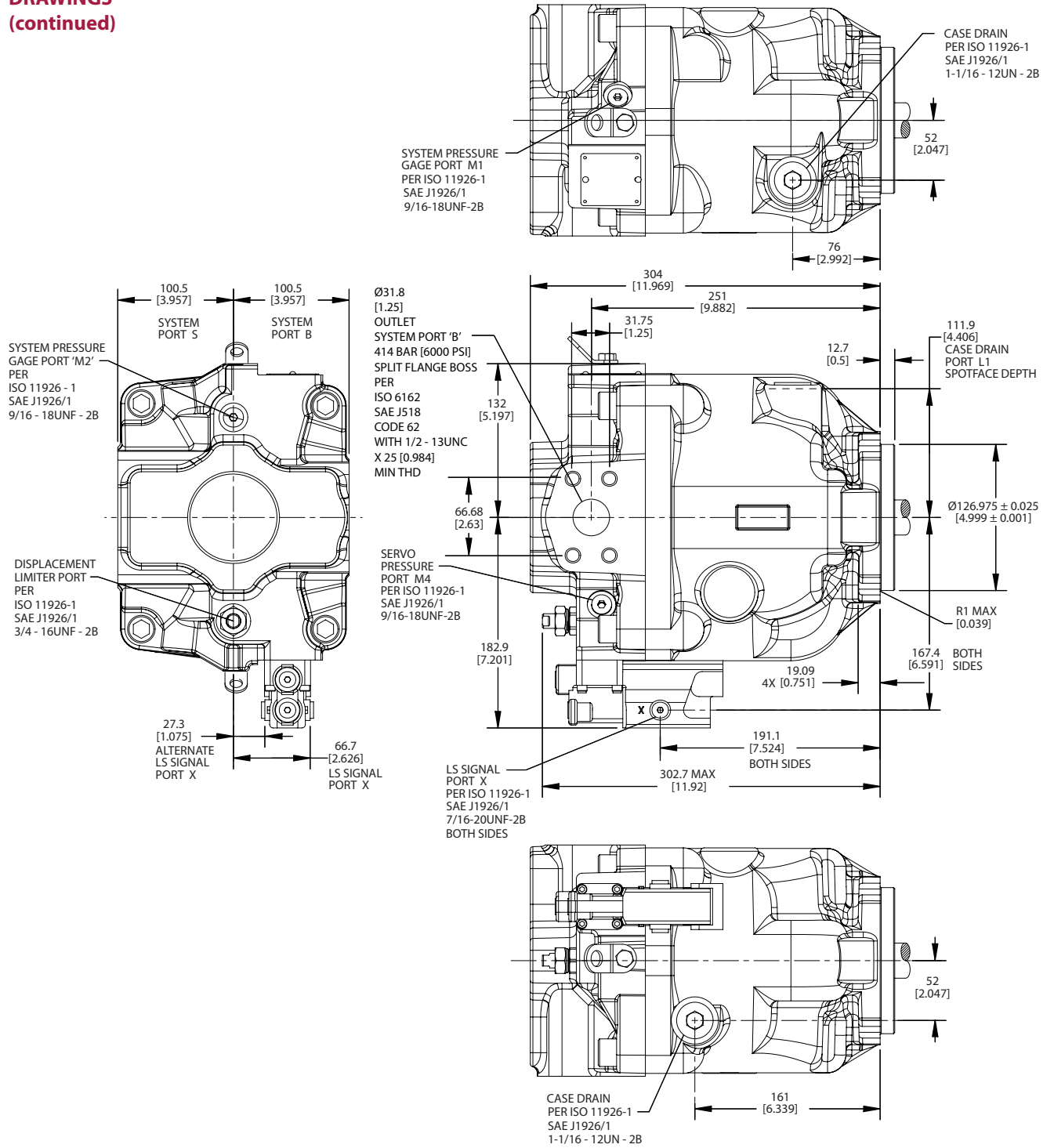

P106 179E



INSTALLATION DRAWINGS (continued)

Radial ported endcap, counterclockwise rotation (continued)

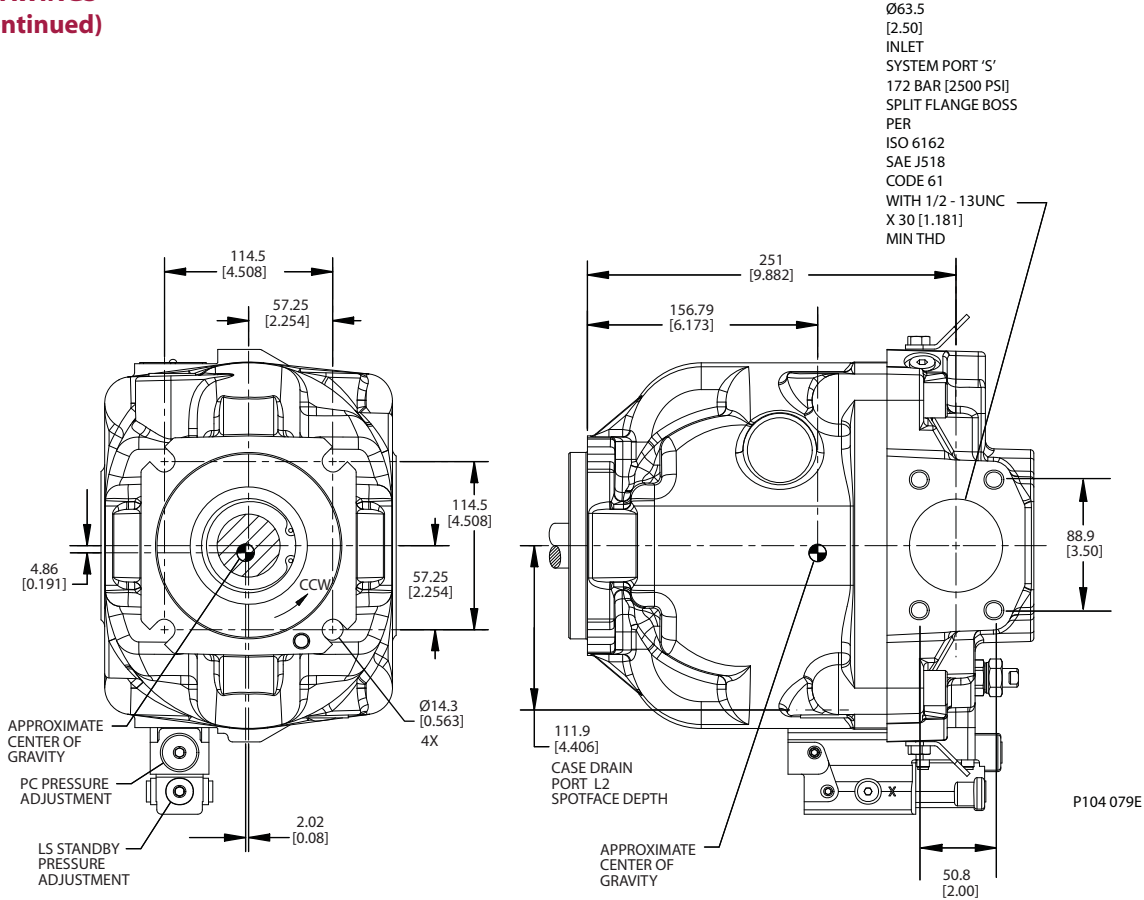

Ø63.5 [2.50]
 INLET SYSTEM PORT 'S'
 172 BAR [2500 PSI]
 SPLIT FLANGE BOSS PER ISO 6162 SAE J518 CODE 61 WITH 1/2 - 13UNC X 30 [1.181] MIN THD

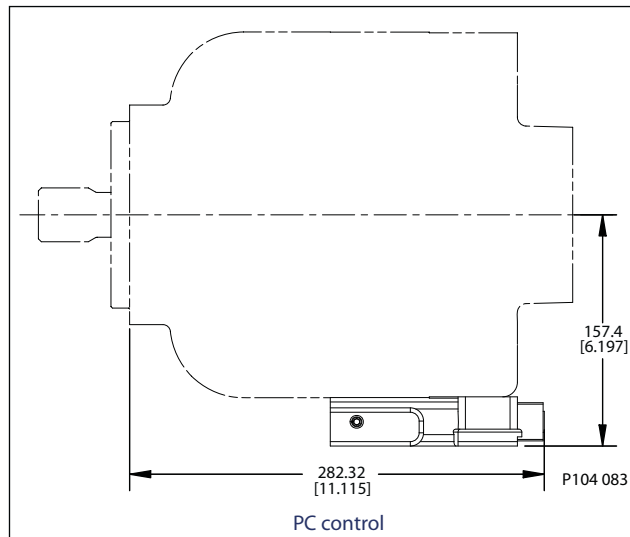



Series 45 Axial Piston Open Circuit Pumps
Technical Information
Notes



OUR PRODUCTS

Hydrostatic transmissions
Hydraulic power steering
Electric power steering
Electrohydraulic power steering
Closed and open circuit axial piston pumps and motors
Gear pumps and motors
Bent axis motors
Orbital motors
Transit mixer drives
Planetary compact gears
Proportional valves
Directional spool valves
Cartridge valves
Hydraulic integrated circuits
Hydrostatic transaxles
Integrated systems
Fan drive systems
Electrohydraulics
Microcontrollers and software
Electric motors and inverters
Joysticks and control handles
Displays
Sensors

Sauer-Danfoss Mobile Power and Control Systems – Market Leaders Worldwide

Sauer-Danfoss is a comprehensive supplier providing complete systems to the global mobile market.

Sauer-Danfoss serves markets such as agriculture, construction, road building, material handling, municipal, forestry, turf care, and many others.

We offer our customers optimum solutions for their needs and develop new products and systems in close cooperation and partnership with them.

Sauer-Danfoss specializes in integrating a full range of system components to provide vehicle designers with the most advanced total system design.

Sauer-Danfoss provides comprehensive worldwide service for its products through an extensive network of Authorized Service Centers strategically located in all parts of the world.

Sauer-Danfoss (US) Company
2800 East 13th Street
Ames, IA 50010, USA
Phone: +1 515 239-6000, Fax: +1 515 239 6618

Sauer-Danfoss GmbH & Co. OHG
Postfach 2460, D-24531 Neumünster
Krokamp 35, D-24539 Neumünster, Germany
Phone: +49 4321 871-0, Fax: +49 4321 871 122

Sauer-Danfoss ApS
DK-6430 Nordborg, Denmark
Phone: +45 7488 4444, Fax: +45 7488 4400