

RAPID-AIR

OPERATING INSTRUCTIONS FOR PILOT RELEASE KITS FOR AIR FEEDS

RAPID-AIR
4601 KISHWAUKEE ST.
ROCKFORD , IL. 61109-2925
PHONE: (815) 397-2578
FAX: (815) 398-3887
WEB SITE: www.rapidair.com

TABLE OF CONTENTS

PAGE

1. TYPES OF PILOT RELEASE CLAMPS
2. OPERATION OF PNEUMATIC PILOT RELEASE CLAMP
3. OPERATION OF PNEUMATIC PILOT RELEASE CLAMP
4. ASSEMBLY DRAWING "A" SERIES
5. ASSEMBLY DRAWING "B" SERIES
6. ASSEMBLY DRAWING "C" SERIES
7. ASSEMBLY DRAWING "D" SERIES
8. ASSEMBLY DRAWING "F" SERIES
9. ASSEMBLY DRAWING "H" SERIES
10. ASSEMBLY DRAWING "L" SERIES
11. ASSEMBLY DRAWING "P" SERIES
12. ASSEMBLY DRAWING "FX" SERIES
13. ASSEMBLY DRAWING "LX" SERIES
14. ASSEMBLY DRAWING "W" SERIES
15. SPRING-LOADED PILOT RELEASE CLAMP ASSEMBLIES

TYPES OF PILOT RELEASE CLAMPS

SPRING-LOADED PILOT RELEASE CLAMP

The spring-loaded stock clamp permits slight movement of the stock for positioning by the pilots or to correct for excessive camber in the strip.

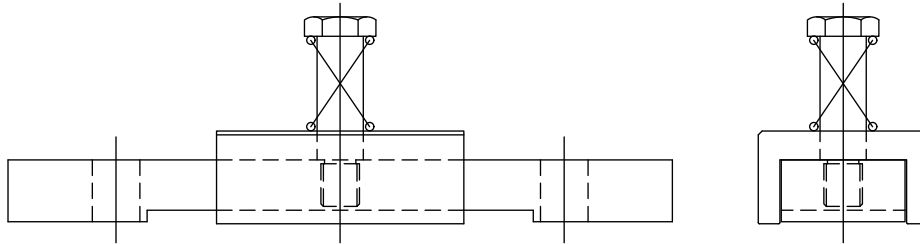

PNEUMATIC PILOT RELEASE CLAMP

The pneumatic pilot release clamp lifts completely to allow for free movement of material to position it when pilots are used. The pilot release clamp is actuated by an electric signal such as a solenoid valve.

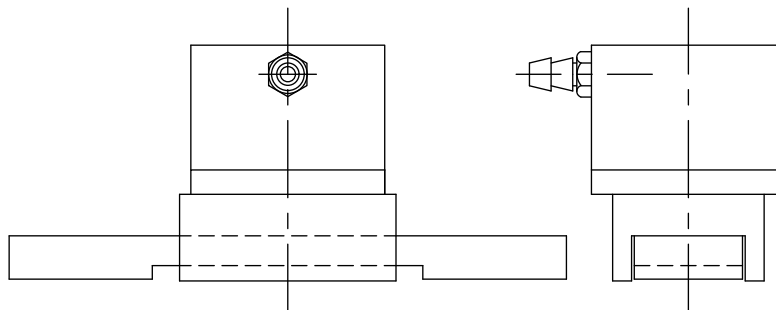

OPERATION OF PNEUMATIC PILOT RELEASE CLAMP

Energize solenoid valve when tool
pilots engage material, pilot clamp
releases material

De-energize solenoid valve with tool
pilots engaged, clamp grips material

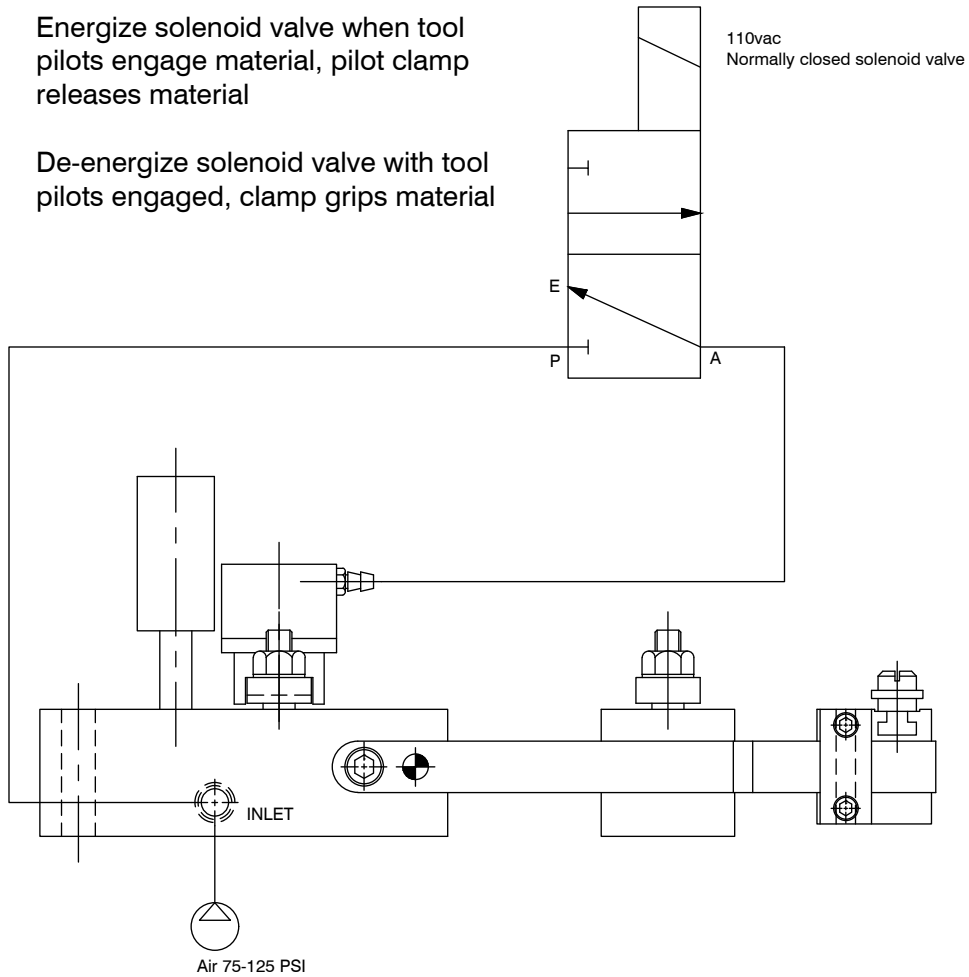

OPERATION OF PNEUMATIC PILOT RELEASE CLAMP

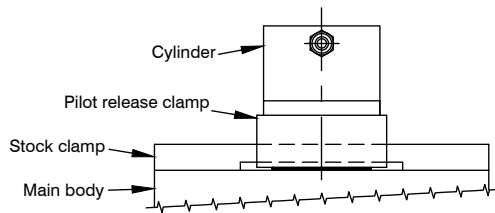

- ① Stock clamp down
Pilot release down
Strip is not able to move

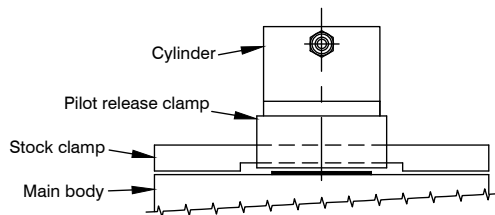

- ② Stock clamp up
Pilot release down
Feed clamp down
Strip is feeding

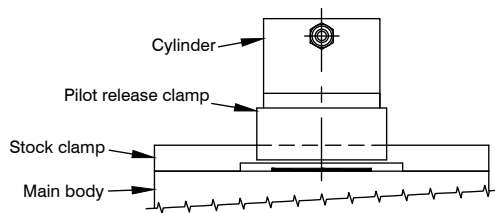

- ③ Stock clamp down
Pilot release up
Feed clamp also up
Strip can be positioned freely

PNEUMATIC PILOT RELEASE CLAMP "A" SERIES

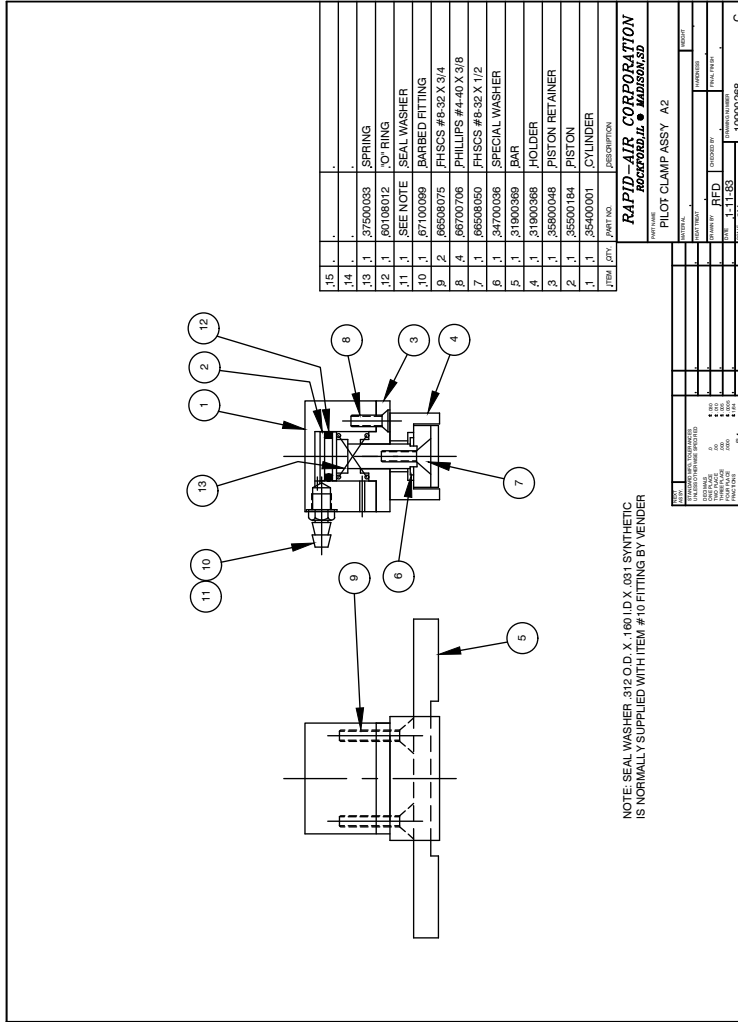

NOTE: SEAL WASHER .312 O.D. X .160 I.D. X .031 SYNTHETIC IS NORMALLY SUPPLIED WITH ITEM # 10 FITTING BY VENDOR

ITEM	QTY.	DESCRIPTION
15	1	CYLINDER
14	1	PISTON
13	1	PISTON RETAINER
12	1	BAR
11	1	SPECIAL WASHER
10	1	PHILLIPS #8-32 X 1/2
9	2	FHSCS #8-32 X 3/4
8	4	BARBED FITTING
7	1	SEAL WASHER
6	1	O'RING
5	1	SPRING

RAPID-AIR CORPORATION
ROCKFORD, IL • MADISON, SD

FROM PART NO. _____

PILOT CLAMP ASSY. A2

REVISIONS

NO.	DATE	DESCRIPTION
1	11-53	REVISED

TOTAL _____

10900288

C

PNEUMATIC PILOT RELEASE CLAMP "B" SERIES

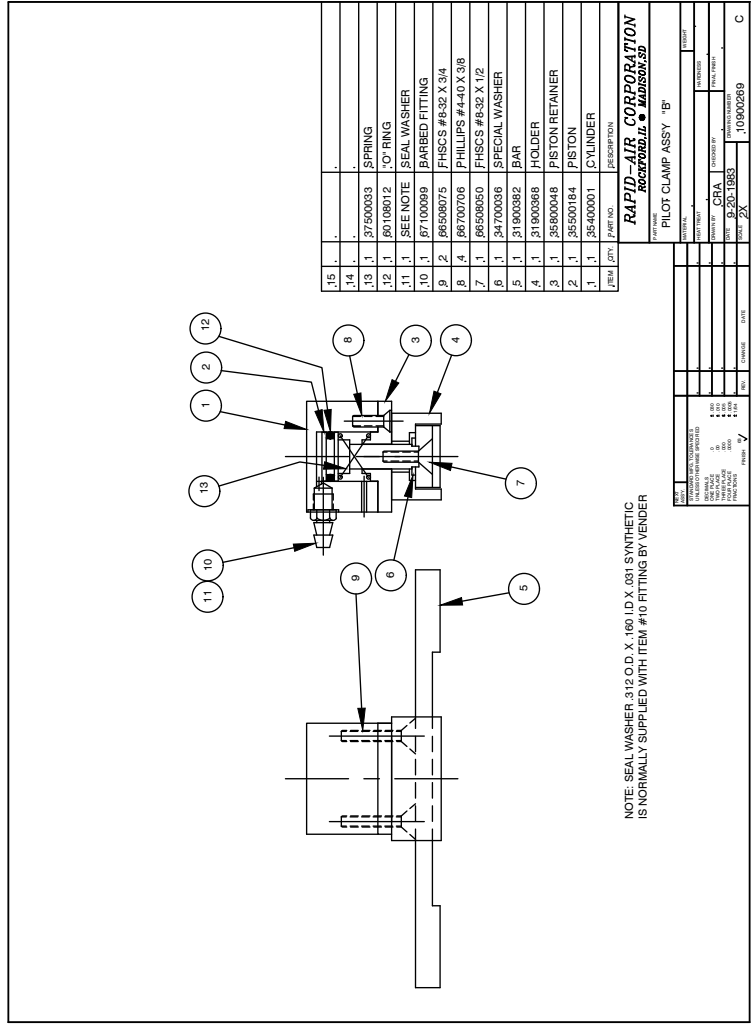

NOTE: SEAL WASHER .512 O.D. X .160 I.D. X .081 SYNTHETIC IS NORMALLY SUPPLIED WITH ITEM #10 FITTING BY VENDOR

ITEM	QTY	PART NO.	DESCRIPTION
15	1		SEAL WASHER
14	1		O-RING
13	1	37500033	SPRING
12	1	36108012	O-RING
11	1	SEE NOTE	SEAL WASHER
10	1	67100099	BARBED FITTING
9	2	66508075	PHILLIPS #4-40 X 3/8
8	4	66700706	PHILLIPS #4-40 X 3/8
7	1	66508050	PHILLIPS #4-40 X 1/2
6	1	34700036	SPECIAL WASHER
5	1	31900368	HOLDER
4	1	31900368	HOLDER
3	1	36500184	PISTON RETAINER
2	1	36500184	PISTON
1	1	36500001	CYLINDER

RAPID-AIR CORPORATION
2824 Forbes Blvd • Baltimore, MD

PART NAME: PILOT CLAMP ASSY "B"

DATE: 9-20-1983

REV: 2X

10900269

C

PNEUMATIC PILOT RELEASE CLAMP "C" SERIES

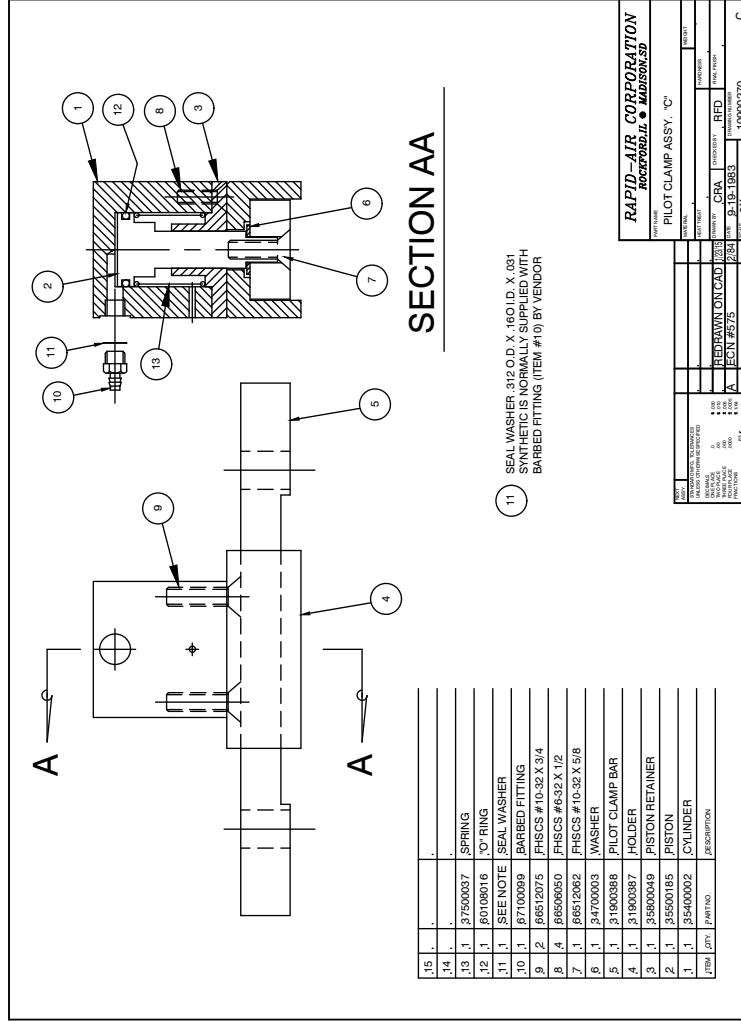

PNEUMATIC PILOT RELEASE CLAMP "D" SERIES

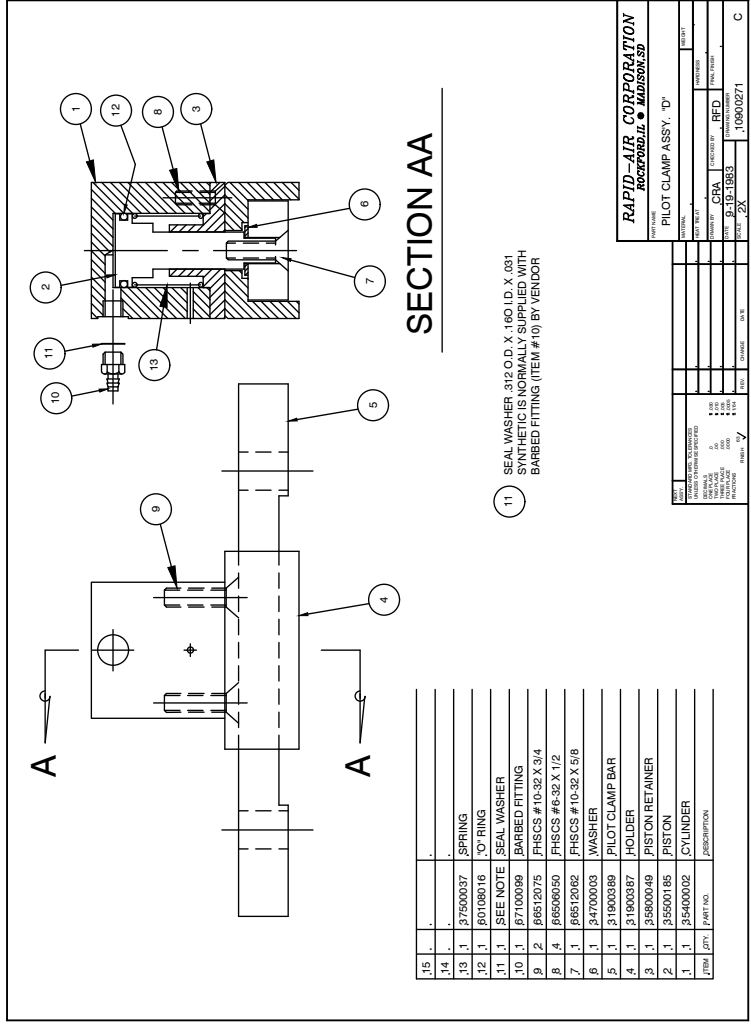

ITEM	QTY	PART NO.	DESCRIPTION
15	1		
14	1		
13	1	37500037	SPRING
12	1	50108016	O-RING
11	1	SEE NOTE	SEAL WASHER
10	1	87100099	BARBED FITTING
9	2	86512075	FHSCS #10-32 X 3/4
8	4	86506050	FHSCS #6-32 X 1/2
7	1	86512082	FHSCS #10-32 X 5/8
6	1	34700003	WASHER
5	1	31900089	PILOT CLAMP BAR
4	1	31900087	HOLDER
3	1	35800049	PISTON RETAINER
2	1	35500185	PISTON
1	1	35400002	CYLINDER

11 SEAL WASHER .312 O.D. X .160 I.D. X .081
 SYNTHETIC IS NORMALLY SUPPLIED WITH
 BARBED FITTING (ITEM #10) BY VENDOR

SECTION AA

RAPID-AIR CORPORATION
ROCKFORD, ILL. 61089-3530

PILOT CLAMP ASSY. "D"

DATE: 9.19.1983
 DRAWN BY: CRA
 CHECKED BY: RFD
 SCALE: 2X
 PART NO.: 109610271
 C

PNEUMATIC PILOT RELEASE CLAMP "F" SERIES

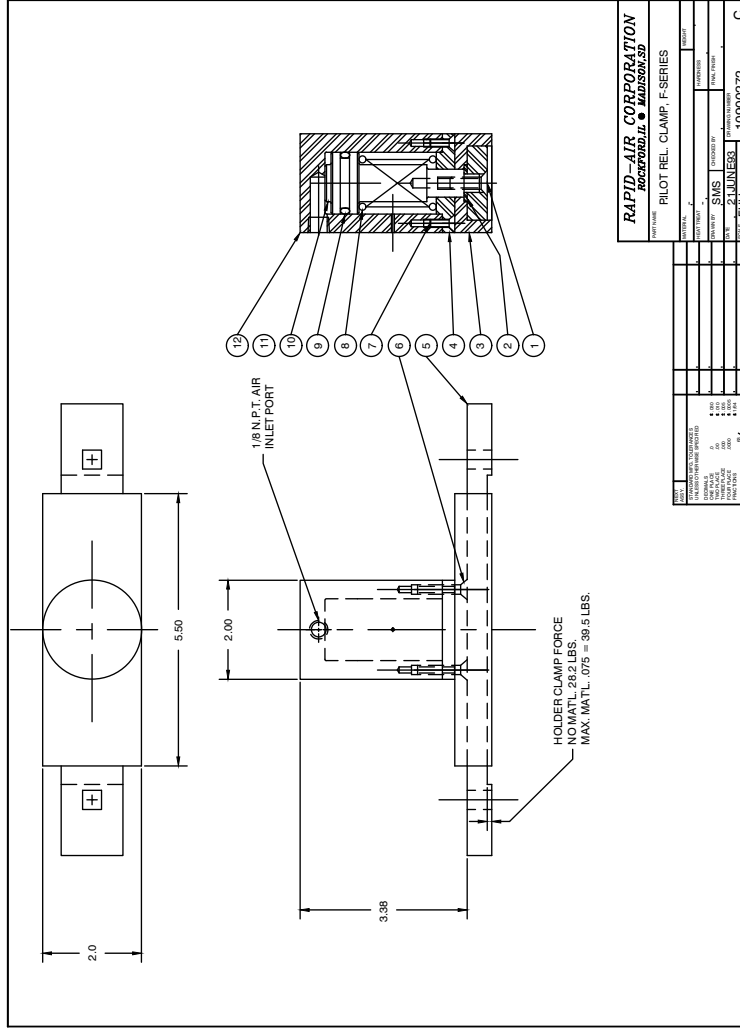

PNEUMATIC PILOT RELEASE CLAMP "H" SERIES

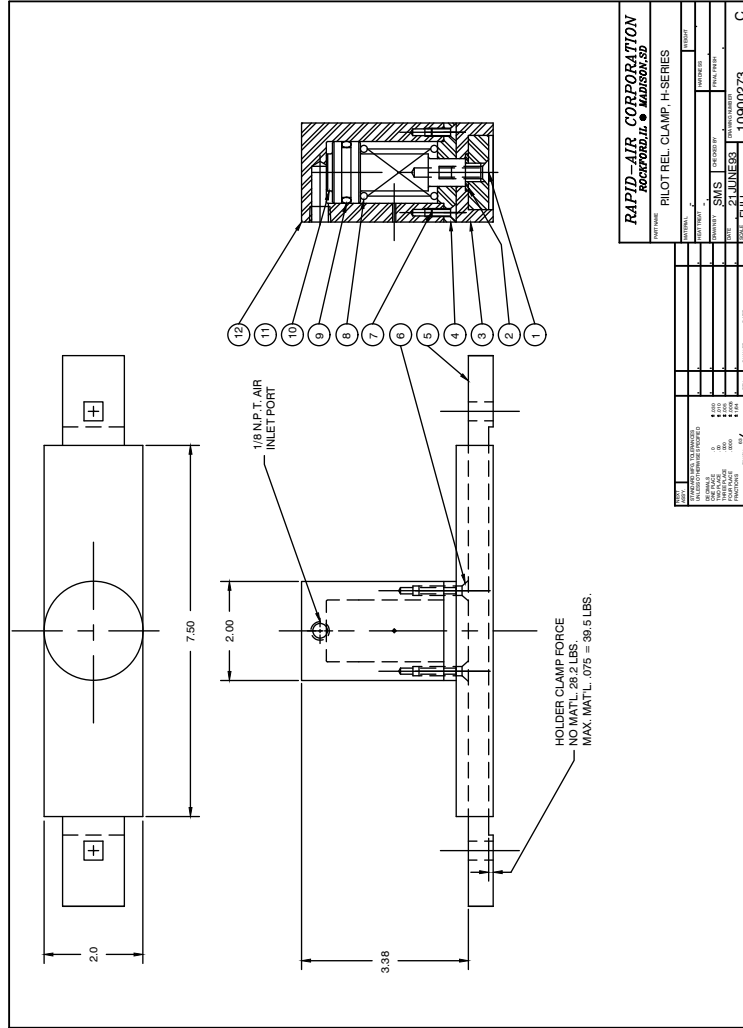

RAPID-AIR CORPORATION	
Rapid Air Division • 4400 S.W. 50th St.	
ITEM NO.	PILOT REL. CLAMP, H-SERIES
QUANTITY	1
DATE	21 JUNE 83
BY	SMS
CHKD BY	
APPROVED BY	
PRICE	.1090273
STATUS	FULL
REVISION	C

PNEUMATIC PILOT RELEASE CLAMP "L" SERIES

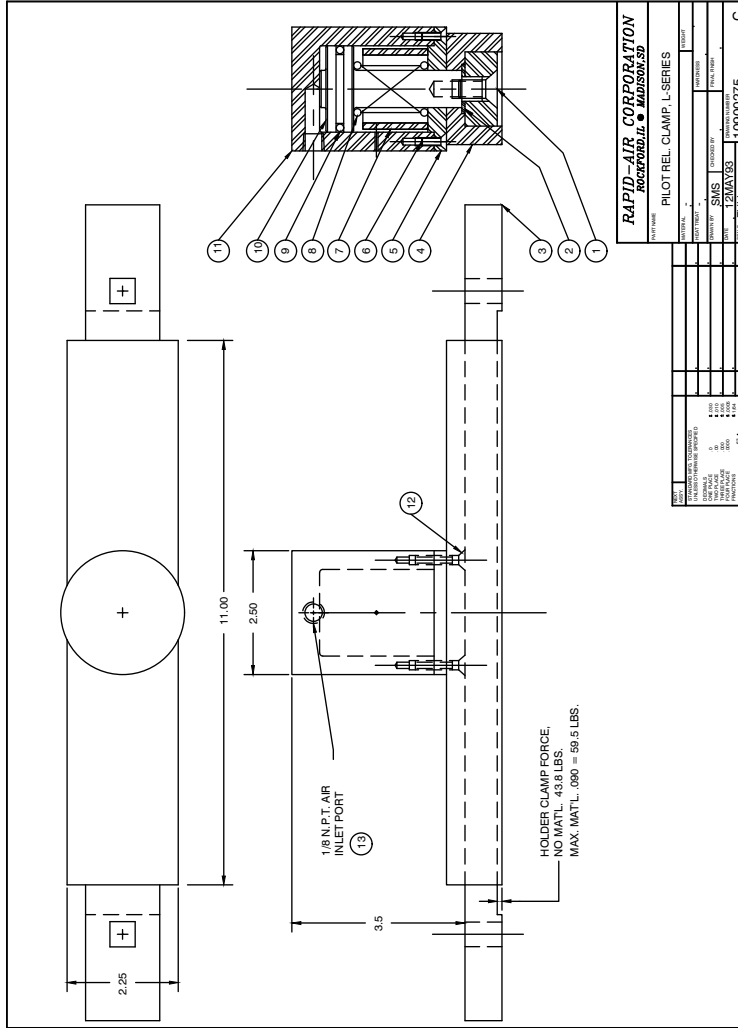

PNEUMATIC PILOT RELEASE CLAMP "FX" SERIES

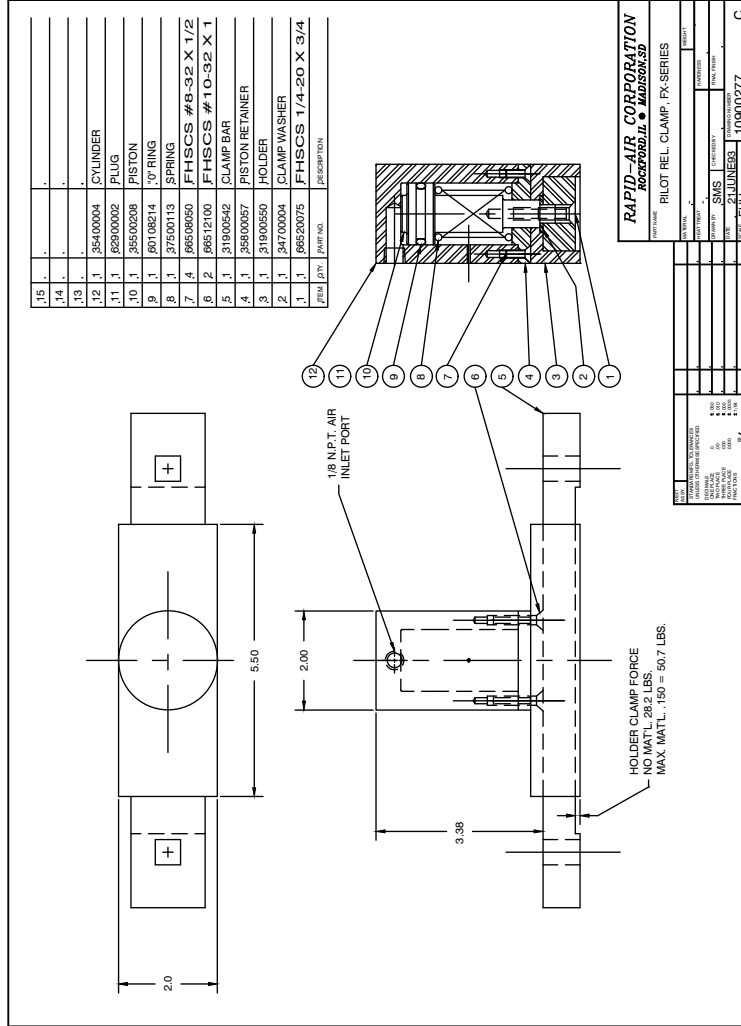

PNEUMATIC PILOT RELEASE CLAMP "LX" SERIES

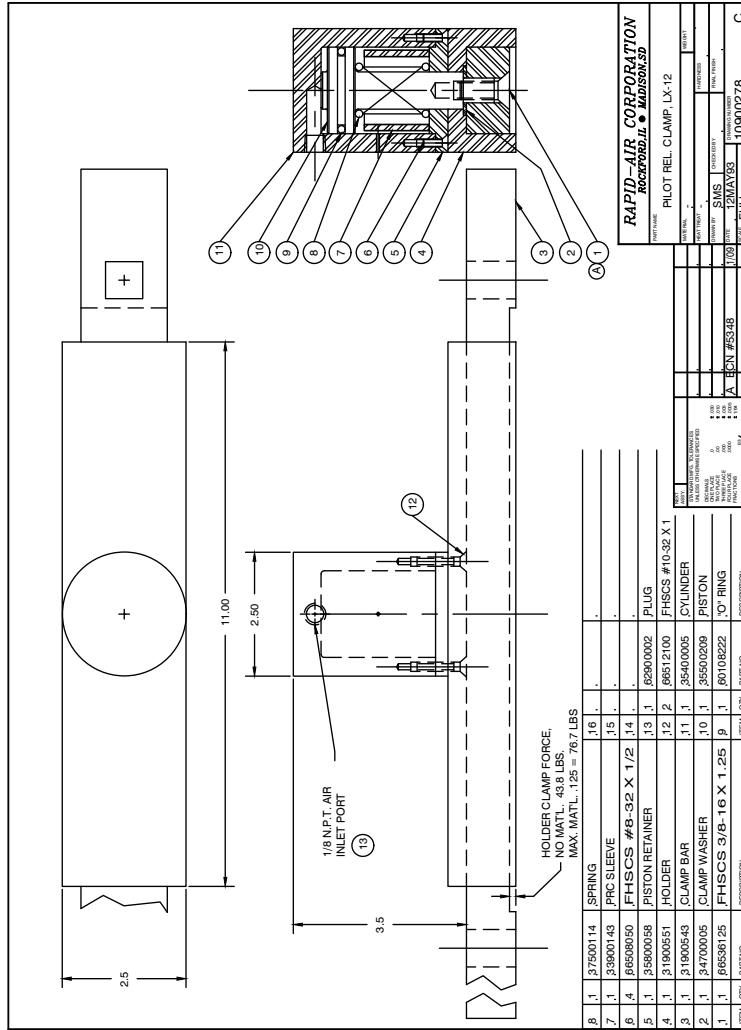

PNEUMATIC PILOT RELEASE CLAMP "W" SERIES

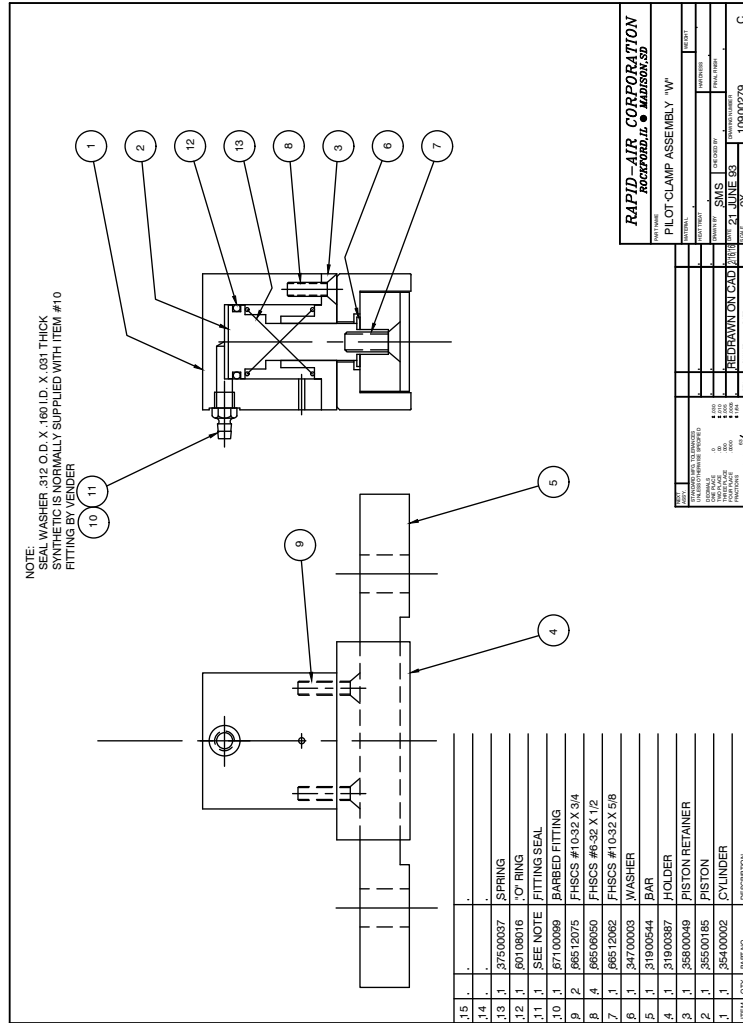

RAPID-AIR CORPORATION
 ROCKFORD, ILL. • HANSON, SD

PILOT CLAMP ASSEMBLY "W"

DATE: 21 JUNE 83
 DRAWN BY: SMS
 CHECKED BY: JZ
 PART NO.: 1.0900279
 C

SPRING-LOADED PILOT RELEASE CLAMP ASSEMBLIES

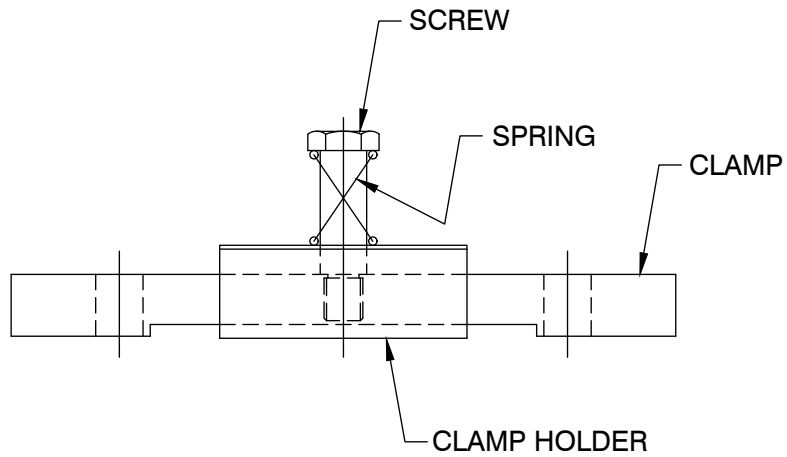

MODEL	CLAMP	CLAMP HOLDER	SPRING	SCREW
"A"	31900107	31900126	37500012	36100014
"B"	31900108	31900126	37500012	36100014
"C"	31900109	31900127	37500013	36100015
"D"	31900111	31900127	37500013	36100015
"F"	31900113	31900128	37500013	36100015
"H"	31900115	31900128	37500013	36100015
"W"	31900124	31900127	37500013	36100015
"L"	31900119	31900129	37500014	36100016
"P"	31900123	31900190	37500014	36100016
"FX"	31900114	31900129	37500014	36100016
"LX"	31900121	31900130	37500014	36100016