

IMPROVING INDUSTRIAL CONTROL SINCE 1936



BECK
ELECTRIC ACTUATORS

HAROLDBECK.COM

AN ISO 9001 COMPANY



MADE IN THE USA
SINCE 1936

THE HISTORY OF
MAKING BECK ACTUATORS
Since 1936



Our Founder: Harold C. Beck
Inventor & Entrepreneur



1936 Where it all began. Harold Beck's Chestnut Hill basement.

1936 - 1942

Later that same year, a bigger basement became necessary. The 2nd BECK Headquarters: 223 W. Mt Airy Ave, Philadelphia, PA.



1942 BECK becomes integral to the war effort, helping the steel & aluminum industries keep pace with skyrocketing demand.

Keeping pace required a move to BECK's first factory. 45 W Durham St., Mt. Airy Section of Philadelphia.





**HAROLD
BECK**
& SONS, INC.
AUTOMATIC
CONTROLS
3640



1970 -
Present

BECK's 4th and
present location:
Terry Dr.,
Newtown, P.A.



→ 1945 And yet more space was
required.

TODAY



STILL SERVING INDUSTRY
Still Made in the U.S.A.



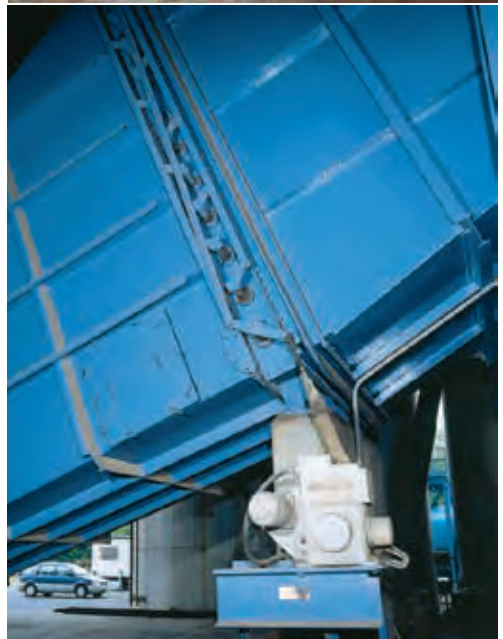
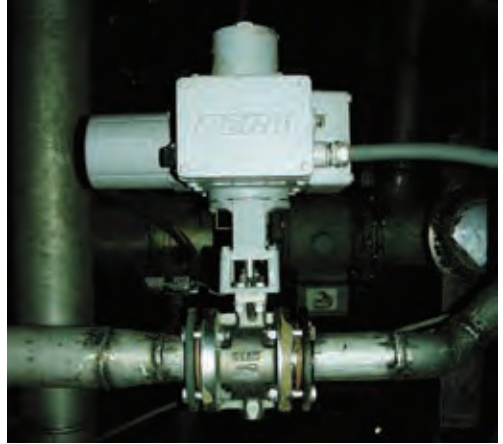

TABLE OF CONTENTS

Introduction 7
 Process Control Improvement 8

Rotary Actuators

Available in a range of torque outputs from 15 to 8,000 lb-ft. Linkage kits, pedestals and valve hardware are available for easy field mounting to final control elements.

Model Group 11 11
 Damper and quarter-turn valve actuators

Model Group 22 25
 High torque damper actuators

Model Group 31 33
 Compact actuators for low torque damper and valve applications

Model Group 57 41
 AC/DC powered quarter-turn valve actuators

Model Group 75 47
 Special purpose actuators for windbox dampers and small valve applications where heat, space and access is an issue.

Linear Actuators

Available with a range of stroke options from 5/16" to 18", custom hardware is available for easy field mounting to final control elements.

Model Group 14 57
 Providing up to 4,000 lbs. of thrust, these actuators incorporate a unique design feature that ensures tight shut-off at the end of travel—commonly used on globe valve applications

Model Group 29 65
 Providing up to 6,100 lbs. of thrust, these actuators incorporate a unique design feature that ensures tight shut-off at the end of travel—even in hazardous locations

Model Group 42 73
 Long stroke actuators providing up to 1,000 lbs. of thrust, ideally suited for burner air register type applications

Specialty Applications 82

Beck electric actuators are available to improve the efficiency of almost any process; including multi-rev drives, burner tilt units, fluid couplings, magnetic couplings, material flow gates and pump handle valves.

Accessories / Services 84

Beck offers a wide range of accessories and services to meet all of your actuation needs; including installation assistance, various options, linkage kits, hazardous location ratings, site surveys and spare parts planning. Beck also offers remotely located electronics for extreme application sites, remote indication and/or control stations and a back-up power option.



INTRODUCTION



Beck's reliability, unique design and expert assistance will help you meet your process control objectives.

INDUSTRY'S CHOICE FOR PRODUCT AND SERVICE EXCELLENCE

Uniquely designed Beck electric actuators offer constant, precise control without the performance and maintenance limitations of typical actuators. Unlike pneumatic and conventional electric actuators, Beck actuators can withstand continuous duty modulation without degradation of performance. Our unique electric actuators combine the positioning necessary for optimum control with the reliability to keep the process running.

- Unique, no-burnout motor allows continuous modulation
- Easy drop-in installation
- Factory calibrated smart digital control electronics
- Virtually maintenance-free
- Three year warranty

Beck has an electric actuator for most industrial control applications and, with over 80 years of industrial actuation experience, we have the know-how to ensure an excellent solution to your actuator needs.

Industries Served

Beck actuators provide precise, reliable positioning of valves, dampers, fluid couplings and other final control elements. Below is a list of just some of the industries that depend on Beck actuators:

- Wood products
- Electric power
- Cement and lime
- Pulp and paper
- Water and wastewater treatment
- Glass
- Minerals
- Chemical/petrochemical
- Steel
- Refineries
- Aluminum and other metals
- Food and beverage

For more detailed information regarding our industrial applications, visit our website:

<http://www.haroldbeck.com/industries.htm>

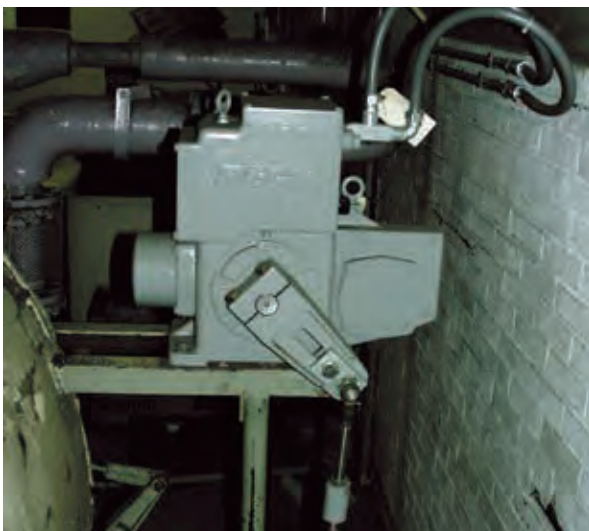

PROCESS CONTROL IMPROVEMENT

Engineered to the High Performance Standards of Today's Sophisticated Control Instrumentation

To fully utilize the power and performance capabilities of today's process control instrumentation, the final control element must be positioned quickly, precisely and consistently. Beck electric actuators provide instantaneous response with the precision and repeatability necessary to fully utilize control system capabilities.

As the emphasis in industry continues to focus on improved quality and efficiency, and as environmental pressures continue to expand, the need for improved process control performance will also continue to broaden. Industry will continue to make large capital investments in state-of-the-art instrumentation and advanced control technologies. However,

real performance improvements will only be realized if the final control element is up to the task. Frequently, the inconsistent and sluggish performance of pneumatic actuators or the unreliability of typical electric actuators is the limiting factor in the performance of the control loop. Therefore, when it is necessary to improve process control performance, the first step is to improve final control element performance.

Beck actuators maximize final control element performance, providing responsive, repeatable actuation. Beck's unique design—incorporating a no-burnout motor, efficient spur gearing and accurate, durable electronics—enables the Beck actuator to start and stop instantly, virtually eliminating dead time and overshoot regardless of load or process conditions.

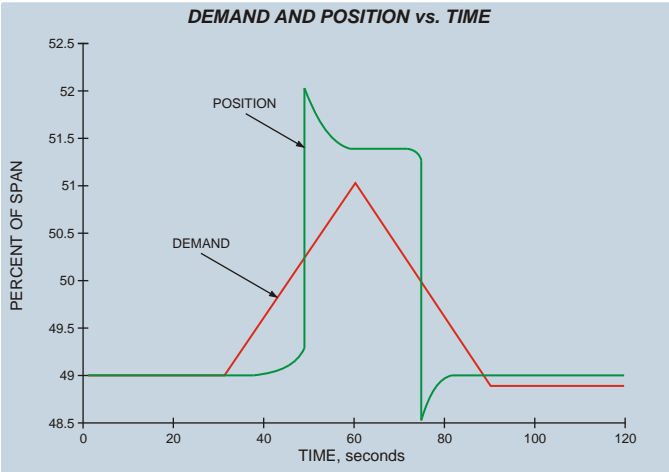

Figure 1-1
Pneumatic actuator response to a 2% ramping demand

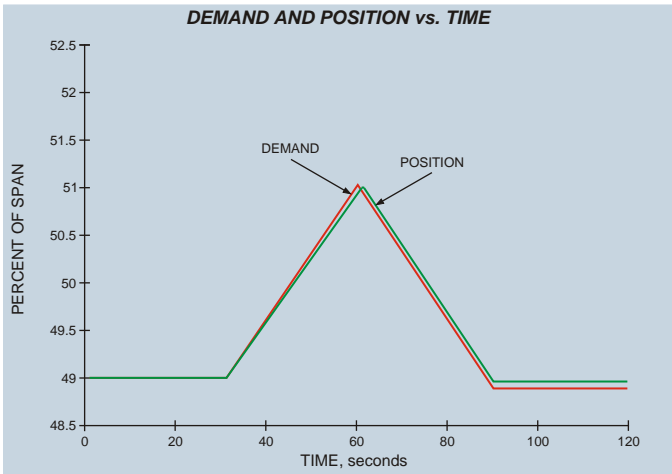

Figure 1-2
Beck actuator response to a 2% ramping demand

More Consistent and Precise than Pneumatics

Beck actuators eliminate the performance bottlenecks created by inconsistent and nonlinear pneumatic actuator performance, which typically varies as a function of frictional and dynamic load, process conditions, the condition of the valve or damper and the performance of actuator accessories such as I/P transducers, regulators and positioners. Unlike pneumatic actuators, Beck actuators provide consistent and repeatable positioning.

Figure 1-1 shows the response of a pneumatic diaphragm valve actuator to a 2% ramping demand signal representative of a control signal modulating the valve. The response demonstrates actuator dead time and overshoot often referred to as “stick and slip.” It is not unusual for stick to completely prevent actuator response to the small demand changes typical of continuous process control.

Figure 1-2 shows the response of a Beck electric actuator to the same demand. The Beck actuator tracks the demand closely, eliminating dead time and the significant overshoot associated with the pneumatic actuator. This type of performance gain in the actuator could be the difference between an uncontrollable flow loop and a tightly controlled one.

Throughout this brochure, the phrase “continuous operation” refers to the actuator’s ability to operate continuously when required for accurate process control, especially during start-up, load changes and process upsets. However, excessive modulation due to process noise, electrical control signal noise, or control signal aliasing will shorten the life of the actuator as well as the valve or damper. For this reason, the control loop should be properly analyzed and tuned to avoid excessive or unwarranted modulation.

More Reliable than Conventional Electric Actuators

Beck actuators incorporate a no-burnout motor, an efficient spur gear drive train and accurate, durable electronics. This unique design eliminates the performance limitations typical of electric actuators, including overheating motors, trips, worm gear wear-induced backlash, coasting and other positioning inaccuracies.

Beck-built motors are specifically designed to provide instant acceleration and deceleration for extremely precise positioning in modulating applications. These reliable motors do not burn out or overheat even under the demanding conditions of an active control loop.

Figure 1-3 illustrates the cool, stable operation of the Beck motor in comparison with conventional single-phase and three-phase motors. Tests were conducted under a 100% duty cycle to simulate maximum control loop activity. The temperature in the conventional motors quickly rose to a dangerous level, tripping the thermal overloads, rendering the motor unavailable for control.

The Beck motor, in contrast, slowly rose in temperature under these service conditions, remaining stable and continuously available for process control.

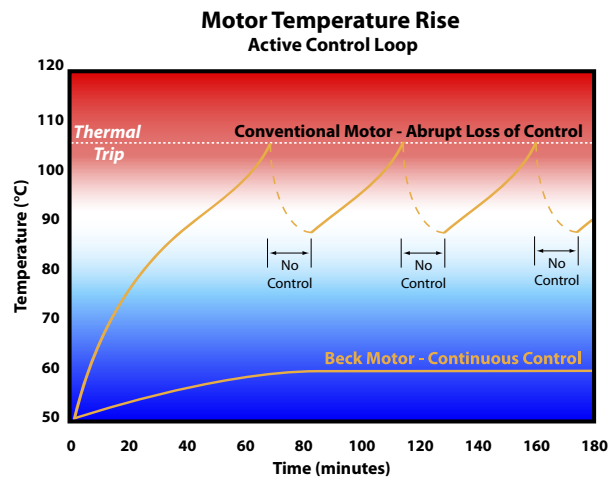
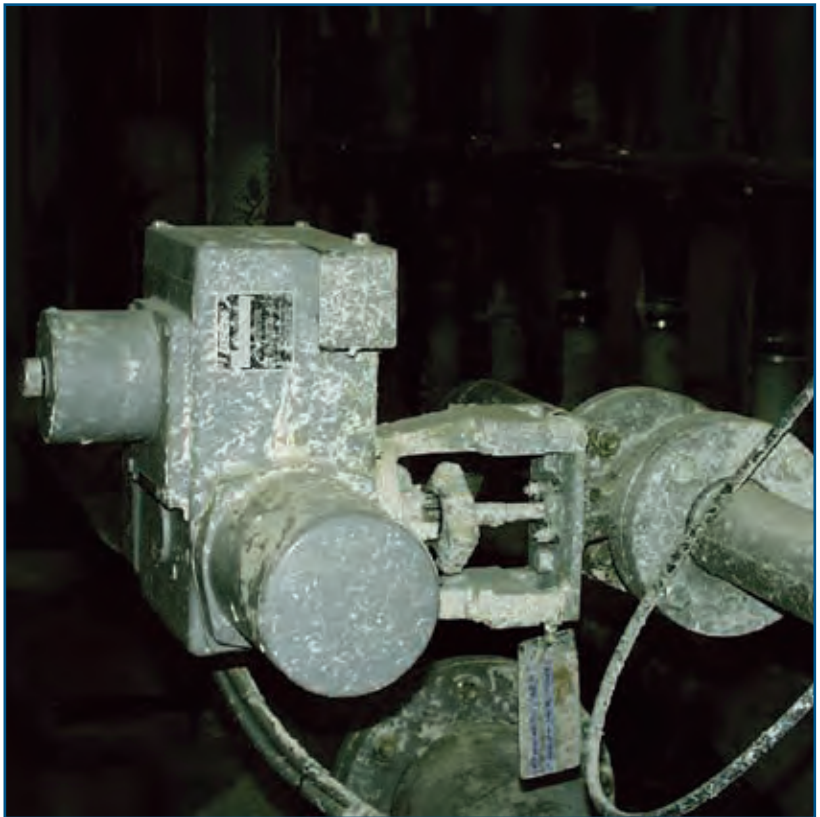

Figure 1-3

Cool, stable operation of the Beck control motor



GROUP 11

DAMPER & QUARTER-TURN VALVE ACTUATORS

Accurate, dependable control for a wide variety of applications.

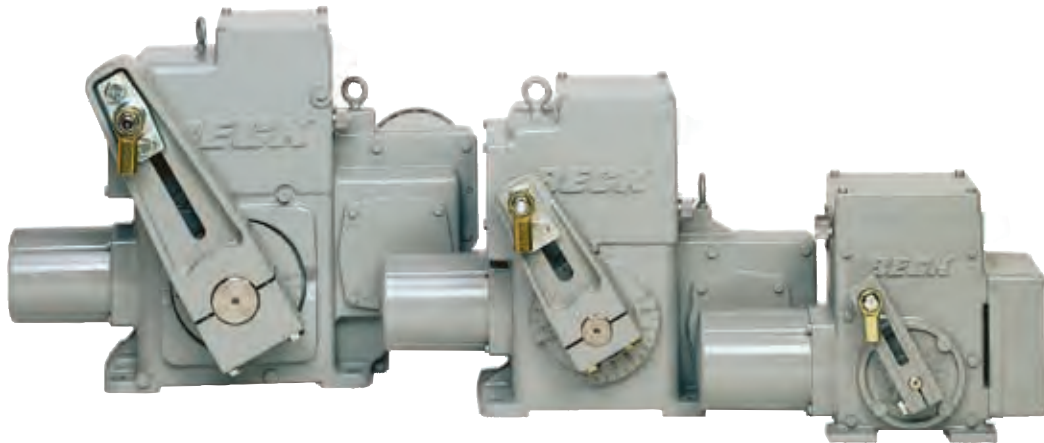

Beck Group 11 electric actuators provide precise, consistent modulation of all types and sizes of dampers and valves. Unlike traditional electric actuators, Beck actuators have no duty cycle limitation and can continuously modulate without overheating.

Beck actuators have the unique ability to quickly, accurately and consistently track the control signal. This ability significantly decreases process variability—improving product quality and reducing operating costs.

Beck has eliminated the problems associated with pneumatic actuators such as stick-slip response, inconsistent performance and air quality issues. Virtually maintenance-free and designed for harsh industrial environments, Beck will drastically reduce your maintenance costs while improving your process control.



Beck Group 11 damper drives are equipped with a specially engineered crank arm. Custom linkage arrangements are available.

Beck Group 11 valve actuators are engineered for direct-coupling on quarter-turn ball, plug and butterfly valves. They may also be installed using specially engineered crank arm and linkage arrangements.

Valves and actuators may be ordered together as pre-engineered assemblies ready for drop-in installation; or actuators can be supplied separately along with the necessary hardware for field installation on existing valves.



FEATURES

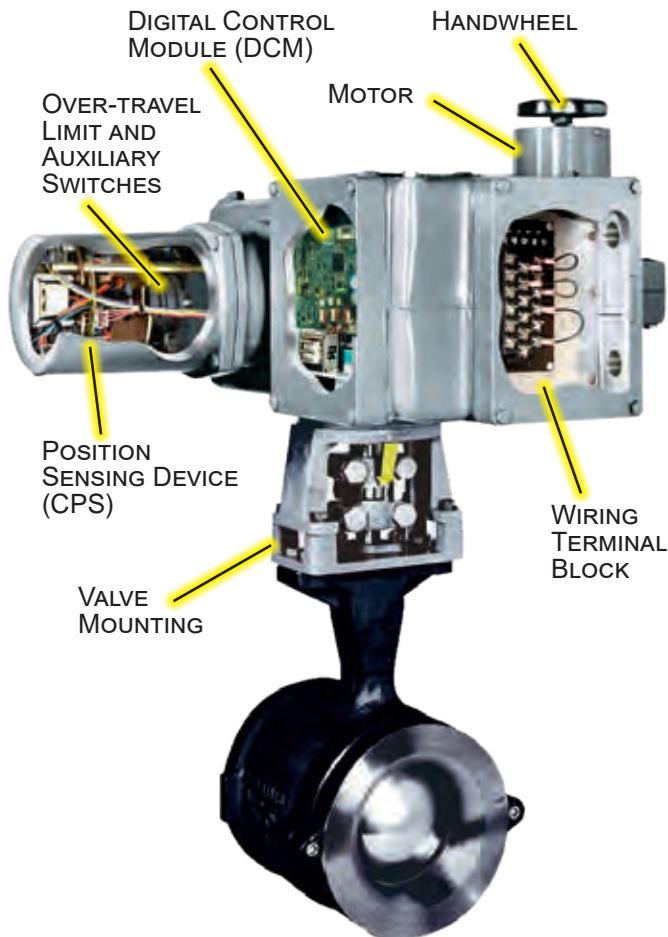
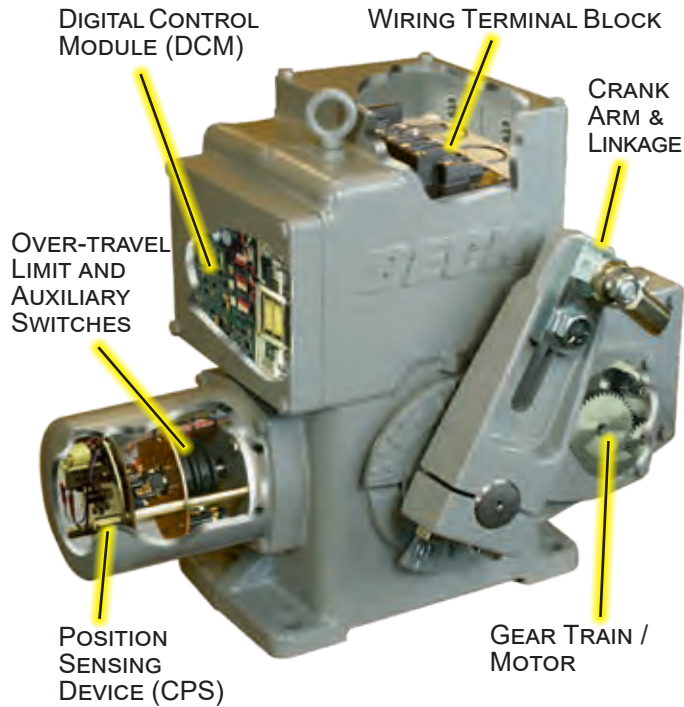

Beck Motor

Precise, Reliable Control

Together with Beck's control electronics and rugged gear train, Beck motors provide the precise, reliable positioning required for modern control loops.

- **Never overheats or burns out**, even under demanding modulating control or stalled conditions.
- Reaches full speed and torque in less than 50 milliseconds and stops within 25 milliseconds, eliminating deadtime.
- Provides extremely accurate positioning in modulating applications.
- **Will not coast or overshoot** the desired position.
- Low current draw of 0.17 A to 3.0 A, and therefore low power consumption, eliminates the need for relays and permits the use of uninterruptible power supplies.
- Maintenance-free with double-lipped, grease-sealed bearings.

Electric Handswitch

Time-Saving Local Operation

Dampers or valves may be operated at their individual locations with the built-in electric Handswitch. This saves time during installation and troubleshooting, allowing online adjustments to be made quickly and easily by bypassing the electronics in the actuator and control system.

The Handswitch also serves as an electrical backup in the event of control system failure.

Auxiliary and Over-travel Limit Switches

Two over-travel protection limit switches are provided. Up to four auxiliary switches are available. Optional switch features:

- SPDT switches rated for a minimum of 6 A at 120 Vac, (three times maximum motor current for most models) to ensure long life.
- Field-adjustable to operate at any point in the actuator's travel range.
- May initiate secondary functions or provide remote indication of actuator position.
- Eliminates unreliable and maintenance-intensive proximity switches.

Group 11 Components

Drive Train

Power and Durability to Maximize Control Availability

Beck's durable gear train maintains accurate, consistent control element positioning even under the demanding conditions of an active control loop.

- Gear trains employ a unique, all spur gear construction of heat-treated alloy steels and ductile iron.
- Efficient, wide-face spur gearing essentially eliminates wear-induced backlash and positioning inaccuracies.
- Durable design provides up to 4 days of protection against intermittent or extended accidental stalls.
- Integral self-locking mechanism ensures that drives hold a minimum of 200% of rated torque with the motor de-energized.

Manual Handwheel

Convenient Manual Control Without Declutch

An easy-to-turn, spoke-free Handwheel is incorporated into the Group 11 design to allow manual operation during installation or power outages.

- Handwheel can be used to move valves and dampers to any position smoothly and easily under full load conditions.
- Mechanical stops in housing prevent manual overtravel.
- The motor operates at 72 or 120 RPM, so the Handwheel poses no safety hazard.

Housing

Superior Protection and Convenient Access to Components

Beck actuators feature a cast aluminum body with individual compartments to protect components from moisture and dirt, and allow easy access for installation and calibration.

- Precision-machined aluminum alloy castings with corrosion-resistant poly-urethane paint provide a rugged, dust-tight, weatherproof Type 4X enclosure. Models approved for use in Hazardous classified locations are available—contact a Beck Sales or Application Engineer for details.

- Individual compartments protect all major components: Motor, DCM, CPS, gear train and installation wiring terminal board.
- Each compartment can be accessed without exposing other components.
- Gasketed, precision-machined covers provide extra protection for harsh indoor and outdoor environments.
- Output and Handwheel shafts are also sealed with weatherproof, double-lip seals.

Mounting Versatility

Beck Actuators can be Mounted in any Orientation for Greater Installation Flexibility

Beck actuators are configured and lubricated in such a way that they may be mounted in any convenient position. This flexibility allows actuators to be installed in hard-to-fit locations.

If housing compartments are accessible, there are no mounting orientation limits.

Mounting Arrangements

Direct-Coupled Configurations

A factory machined coupling is used to connect the actuator directly to the valve. This configuration is compact in design and is ideal for applications where a constant torque is desired over the full 90° range of travel.

Crank Arm / Linkage Configurations

Valve / actuator assemblies may be specified with crank arm and linkage mounting arrangement. This design allows 100° actuator travel, thus providing variable torque distribution and increased seating effectiveness.

- With linkage characterization, high seating torques can be obtained for certain valve types.
- Standard bracket and linkage mounting hardware is available for most popular valve types.
- Custom mountings are easily handled allowing Beck actuators to be economically mounted to virtually any rotary valve.
- Link-Assist™ computer program helps you specify the ideal arrangement for your application (see Appendix).

CONTROL OPTIONS & SAMPLE WIRING DIAGRAMS

Diagrams are functional—customer wiring may vary. Certified wiring diagrams can be provided for the actuator you select.

Modulating Option 9

Digital Position Control with Contactless Position Sensing

The Beck DCM positions the actuator in proportion to an input current or voltage signal, and the CPS provides integral feedback for the DCM. A 4–20 mA position feedback signal is available for remote indication. Foundation Fieldbus is also available.

The DCM may be used to provide pre-determined positioning of the actuator upon loss of input control signal.

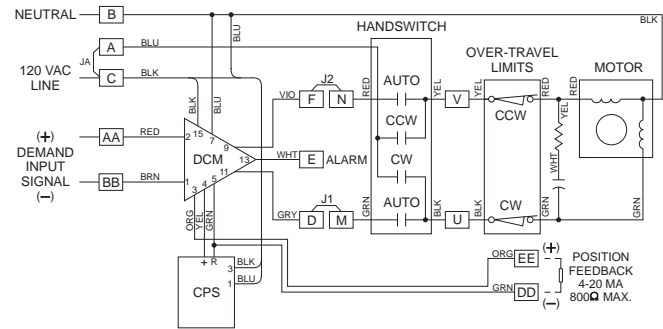

Modulating Option 8

Analog Position Control with Contactless Position Sensing

The Beck ESR positions the actuator in proportion to an input current or voltage signal, and the CPS provides integral feedback for the ESR and isolated feedback for remote position indication (also available without external feedback).

The ESR may be used to provide pre-determined positioning of the actuator upon loss of input control signal.

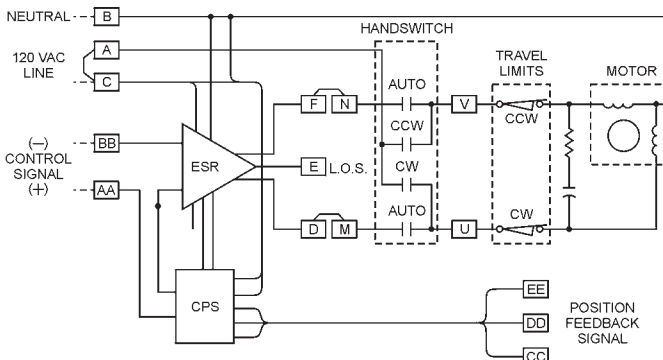

Modulating Option 7

Analog Position Control with Potentiometer Position Sensing

The Beck ESR positions the actuator in proportion to an input current or voltage signal. A film potentiometer is used in place of the CPS for position sensing and internal feedback to the ESR.

An optional auxiliary potentiometer, requiring external power, may be added for remote position indication or control. The ESR may be used to provide predetermined positioning of the drive upon loss of input control signal.

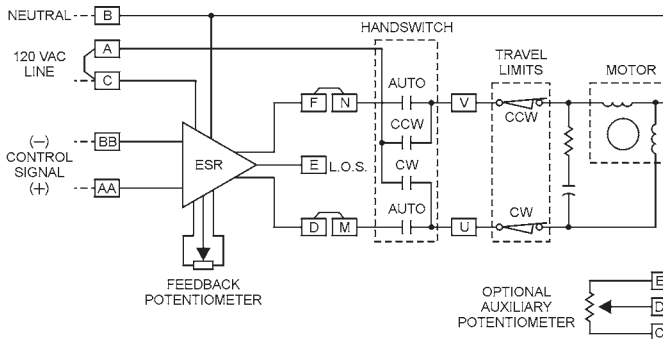

Modulating Option 6

Direct AC Control with Contactless Position Sensing

Control option 6 features clockwise / counterclockwise control from a remote automatic controller or manual switches.

The CPS provides a feedback signal for remote position indication.

If the available 120 / 240 Vac control voltage is not able to supply enough current to operate a actuator, a Relay Board must be added to the control compartment.

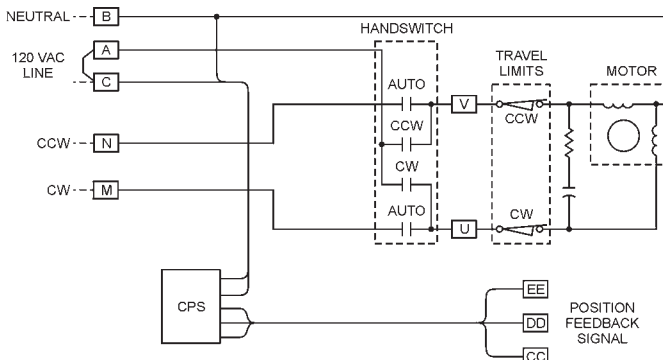

Modulating Option 5

Direct AC Control with Potentiometer Position Sensing

Actuated in clockwise or counterclockwise from a remote location or manual switches, this configuration includes a 1000 ohm film potentiometer for remote feedback. An optional auxiliary 1000 ohm potentiometer can be added as an additional remote position indication.

If the available 120 / 240 Vac control voltage is not able to supply enough current to operate an actuator, a Relay Board must be added to the control compartment.

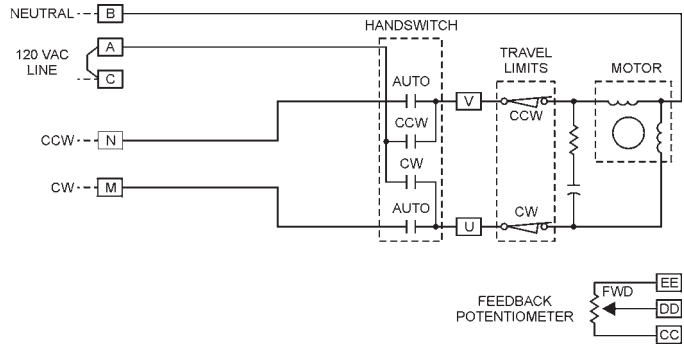

Multi-Position Option 4

Direct AC Control with Cam-Operated Switches to Stop Actuator Travel

Option 4 incorporates adjustable cam-operated switches to stop the actuator in 6 positions (two end-of-travel, four intermediate positions), or 3 positions (one intermediate position). 4-position and 5-position control can also be attained using a different number of switches.

Standard end-of-travel switches have extra contacts that can be used for external signaling or interlocking.

Configuration shown: BASIC 3-position.

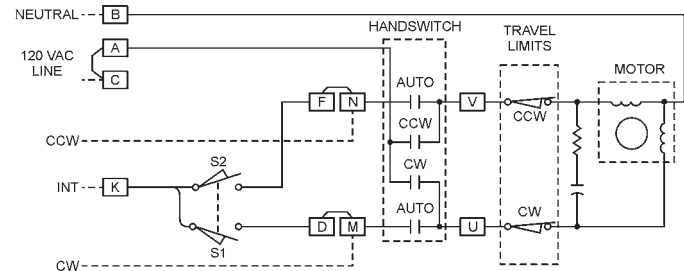

Open / Close Option 3

Direct AC Control

For simple open / close operation, Option 3 includes two limit switches, which stop the actuator at each end of travel and may also be used for external signaling.

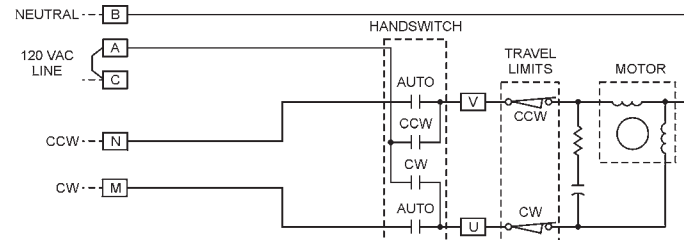

Other operating voltages available

All of the options described on this page and the previous page are also available for 208, 240, 380, 415, 480 & 575 Vac operation instead of 120 Vac operation.

Auxiliary Switch Terminals

Auxiliary switches may be added for control or annunciation functions. Switches are rated at 6 A 120 Vac. They may be factory-set or field-adjusted to operate at any point in the actuator's travel.

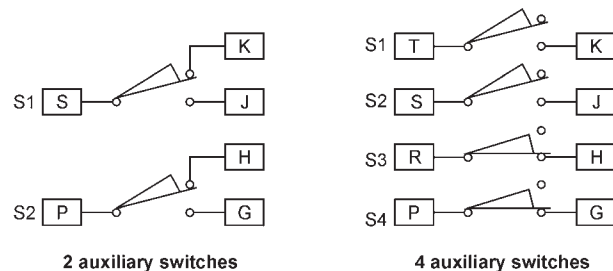

2 auxiliary switches

4 auxiliary switches

SPECIFICATIONS

Use the charts on this page to create a full specification model number.

First, select the basic model no. from the chart at right (blue column) and enter the first four digits in the blue "Model No." field below. Now select the control option that suits the application requirements using the information in the chart at the bottom of the page (brown column). Enter the control option designation number (3 through 9) in the brown area of the "Model No." field below.

The next step is to determine the required torque for the application as well as select the full stroke time in seconds as shown in the chart at right (green and yellow columns). Enter the selected torque option in the green "Torque" field and the selected timing option in the yellow "Timing" field below.

Finally, select the number of auxiliary switches desired (0, 2 or 4) and enter that number in the purple "Aux. Switches" field below.

The full specification model number is complete and can be used to specify a Beck drive.

For example, **11-409-1000-40-2** denotes an 11-400 basic model for modulating control (option 9 Digital Control Module) that is rated for 1,000 lb-ft (1355 N•m) torque output with a full stroke time of 40 sec/100°. It is equipped with two auxiliary form C switches.

TORQUE, TIMING & MOTOR CURRENTS

Basic Model No.	Torque (lb-ft)[N•m]	Timing ^{4*} (sec./100°)	Timing ^{4**} (sec./90°)	Motor 1,2,3 Current (A)
11-150 (100°)* 11-160 (90°)**	15 [20]	11	10	0.31
	20 [27]	20	18	0.17
	40 [54]	12	11	0.32
	40 [54]	20	18	0.31
	40 [54]	40	36	0.17
	60 [81]	60	54	0.17
	80 [108]	24	22	0.32
	80 [108]	40	36	0.31
	80 [108]	90	81	0.17
11-200 (100°)* 11-260 (90°)**	125 [169]	20	18	0.71
	125 [169]	40	36	0.43
	175 [237]	60	54	0.43
	250 [339]	24	22	0.74
	250 [339]	40	36	0.71
11-300 (100°)* 11-360 (90°)**	250 [339]	75	68	0.43
	300 [406]	24	22	0.74
	300 [406]	40	36	0.71
	300 [406]	100	90	0.43
	400 [542]	36	32	0.74
	400 [542]	60	54	0.71
	550 [745]	45	41	0.74
11-400 (100°)* 11-460 (90°)**	550 [745]	75	68	0.71
	650 [881]	100	90	0.71
	350 [474]	24	22	1.30
	550 [745]	40	36	1.30
	650 [881]	24	22	2.30
	800 [1084]	60	54	1.30
11-400 (100°)* 11-460 (90°)**	1,000 [1355]	24	22	3.00
	1,000 [1355]	40	36	2.30
	1,000 [1355]	75	68	1.30
	1,500 [2032]	100	90	1.30
	1,800 [2439]	36	32	3.00
	1,800 [2439]	60	54	2.30
11-430 (100°)*	2,900 [3929]	72	n/a	3.00
	2,900 [3929]	120	n/a	2.30
	5,200 [7046]	108	n/a	3.00
	5,200 [7046]	180	n/a	2.30

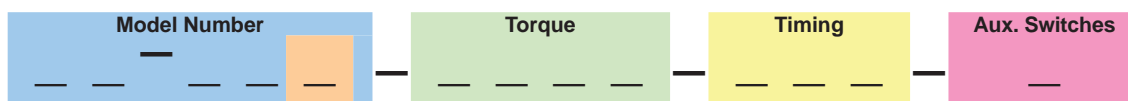

0 = Standard
2 or 4 = Optional⁵

CONTROL OPTION CHART⁶

Control Option	Control Mode	Control Board	Std. Control Input	Position Sensor	Std. Position Feedback
9	Modulating	DCM [^]	4-20 mA	CPS	4-20 mA
8	Modulating	ESR	4-20 mA	CPS	4-20 mA
7	Modulating	ESR	4-20 mA	Film Potentiometer	None
6	Modulating	None	120 Vac	CPS	4-20 mA
5	Modulating	None	120 Vac	Film Potentiometer	Film Potentiometer
4	5-Position	None	120 Vac	None	None
4	3-Position	None	120 Vac	None	None
3	2-Position (Open / Close)	None	120 Vac	None	None

¹ Unique Beck motor design has starting & stall current that approximate running current, so thermal overload protection is not required--just provide normal short-circuit protection.

² Motor currents shown are 60 Hz -- 50 Hz currents do not exceed 120% of 60 Hz levels.

³ Actuator current @ 240 Vac is approx. 1/2 the 120 Vac current (motor current does not change @ 240 Vac).

⁴ Stroke timings shown are based on 60 Hz power; 50 Hz power provides timings 20% greater.

⁵ 2 or 4 auxiliary switches are available for most Group 11 actuators. Contact the factory regarding switch availability on control option 4 models.

Standard travel limit switches have extra contacts which can be used for external signaling on 2-, 3- or 5-position control modes.

⁶ Contact the factory if the signal options listed do not meet your requirements.

[^] Smart Digital Control Module with std. HART communication capabilities; optional Foundation Fieldbus, Profibus PA and Modbus RTU.

Input Power

120 Vac, single-phase 50 or 60 Hz
208, 240, 380, 415, 480, 575 Vac, 50 or 60 Hz—requires optional integral transformer

Operating Conditions

–40° to 85°C (–40° to 185°F)
–50° to 85°C (–58° to 185°F); optional for 11-200/-300-400 models
0 to 100% relative humidity

Isolation

Demand Input and Position Feedback signals are isolated from the ground and the ac power line.

Action on Loss of Power

Stays in place.

Control Types

Modulating with Digital Control Module (DCM)
Modulating with analog electronics (ESR)
Modulating direct ac motor control
3 or 5 position control
2 position (open/close) control

Input and Feedback Signals

Depends upon the actuator control option. See page 16.

Available Communication Protocols (control option 9)

HART® (standard). Options: Foundation Fieldbus, Profibus PA and Modbus RTU.

Minimum Step Size (Modulating Control)

DCM -- 0.10% (0.15% typical) (configurable)
ESR -- 0.10% (0.15% typical)
Direct AC -- 0.1° (function of control system capabilities)

Stall Protection (protects actuator and driven elements under stall conditions)

DCM -- Time to stall is configurable from 30 to 300 seconds.
Other control types -- Optional Stall Protection Module is available.

Action on Loss of Input Signal (Power On)

Stays in place or, with some options, is field configurable to move to any preset position.

Overtravel Limit Switches (Dedicated)

Two Form C switches provide overtravel protection.

Auxiliary Switches (Non-Dedicated)

Up to four 6A, 120 Vac switches available. Switches are cam-operated and field-adjustable.

Handswitch

Permits local electrical operation independent of the controller signal. Standard on all units. An optional auxiliary contact can be used to indicate that the Handswitch is in "AUTO" mode or to sound an alarm if it is taken out of "AUTO". A locking Handswitch is also available.

Enclosure

Precision-machined, aluminum alloy castings painted with corrosion-resistant polyurethane paint provide a rugged, dust-tight, weatherproof enclosure. Type 4X; IP68, 3 meters/48 hours.

NOTE: Internal water damage is not covered by warranty.

Standards

CSA Labeled (US & Canada); CE Compliant

NOTE: For standards not specifically listed, please call Beck for more information at 215-968-4600.

Hazardous Locations (Optional)

Class I, Div. 2, Groups A, B, C & D; Class II, Div. 1, Groups E, F & G; Class II, Div. 2, Groups F & G;
Class III, Div. 1 & 2.

NOTE: May not be available with all options & models. If these ratings do not meet your requirements, call Beck at 215-968-4600.

Mounting Orientation

Any orientation—no limitations.

OUTLINE DIMENSION DRAWINGS

Model 11-150

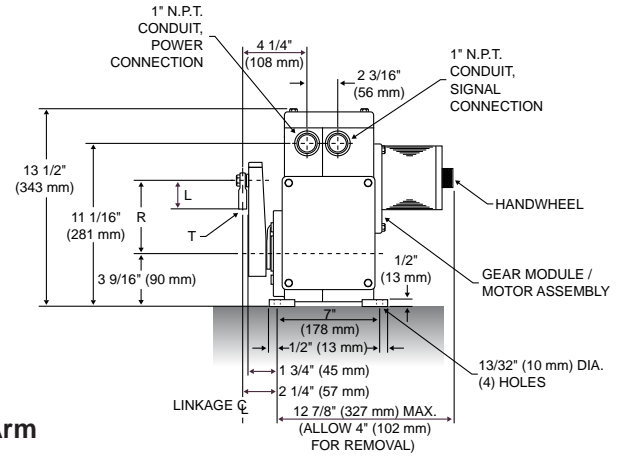
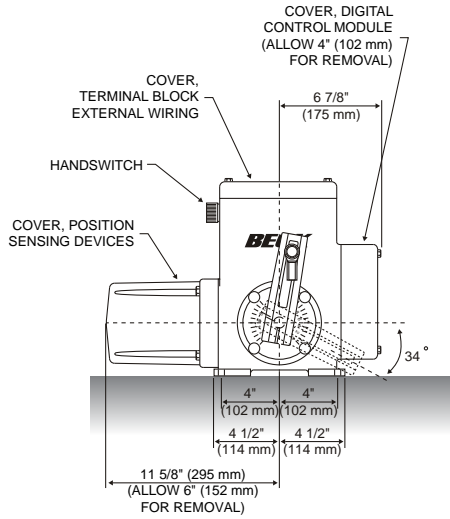

Crank Arm

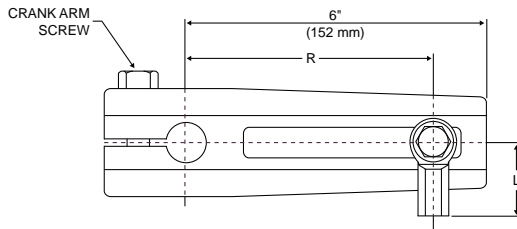

ADJUSTABLE RADIUS "R" 1 1/2" (38 mm) TO 5 1/8" (130 mm)

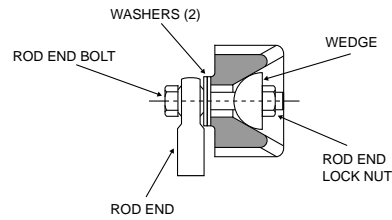

Model 11-160

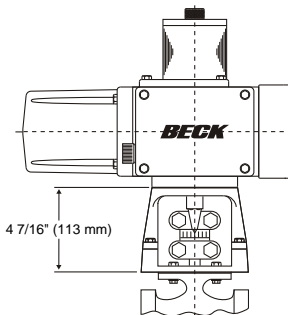
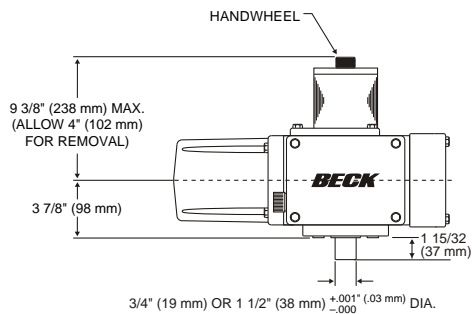
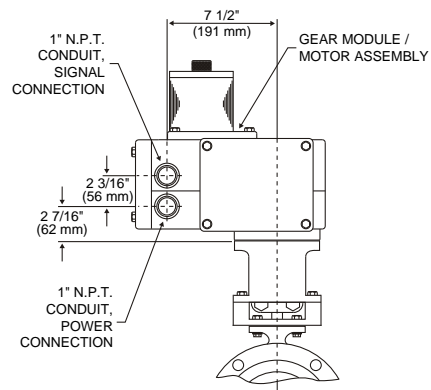
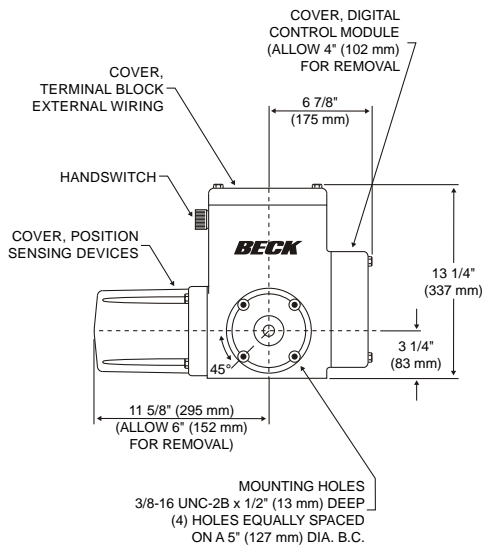

Actuators may be mounted in any orientation.

Model 11-200/-300

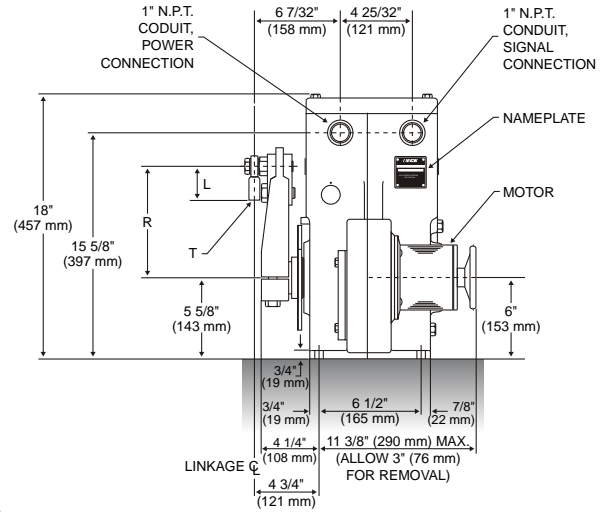
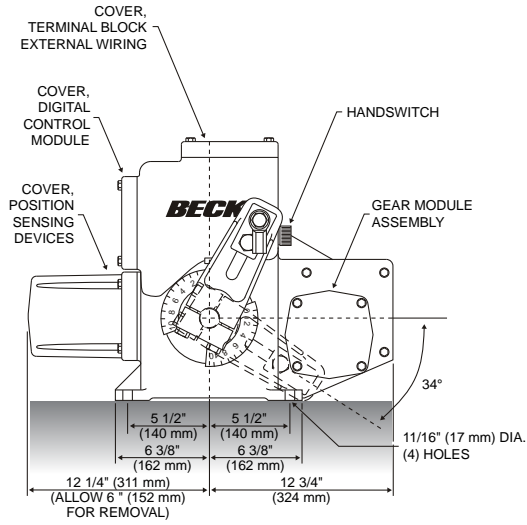

Crank Arm

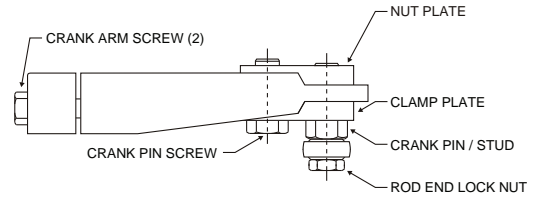
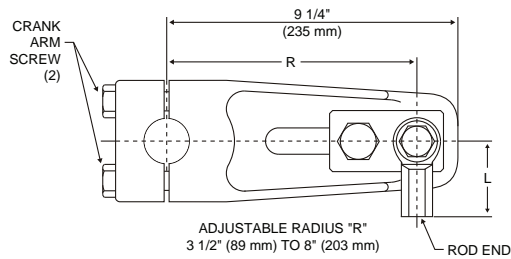

Model 11-260/-360

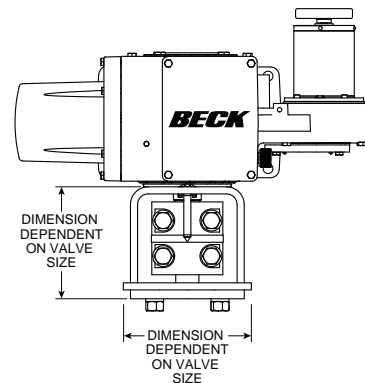
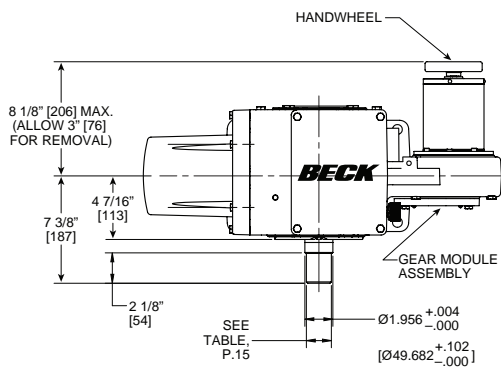
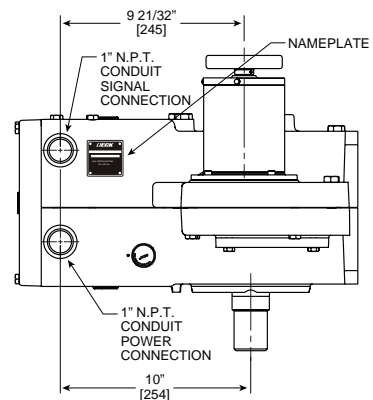
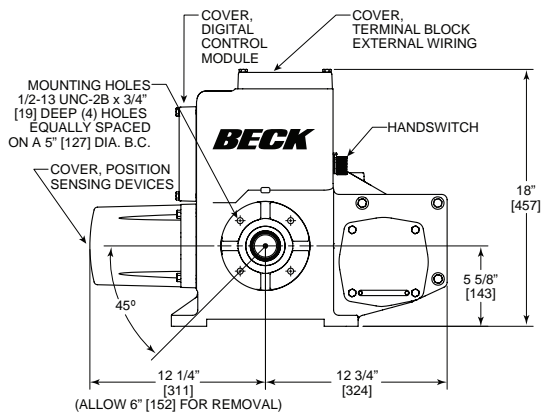

OUTLINE DIMENSION DRAWINGS

Model 11-400

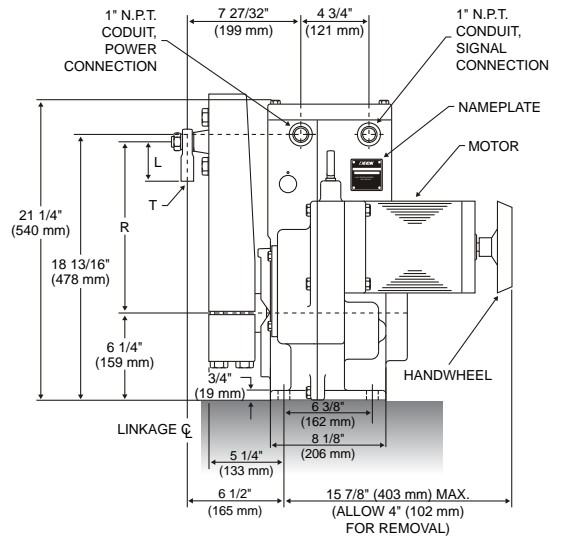
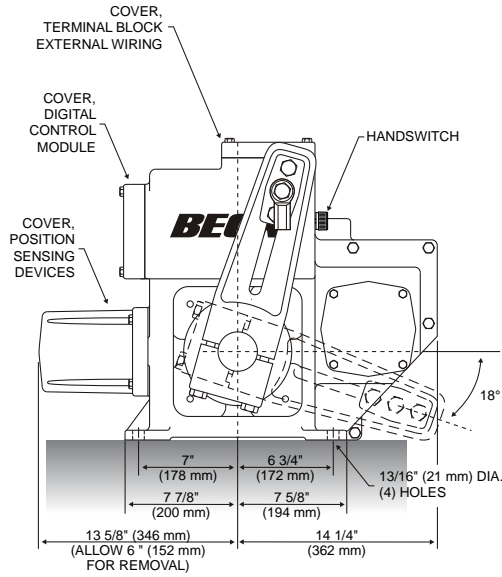

Crank Arm

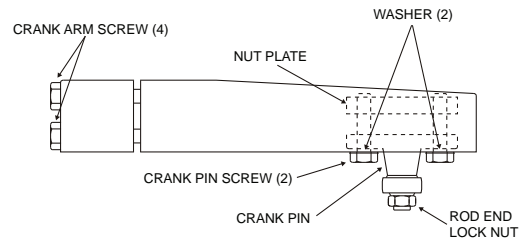
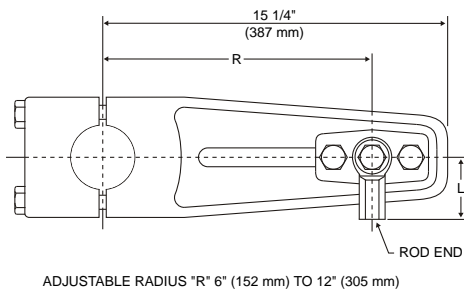

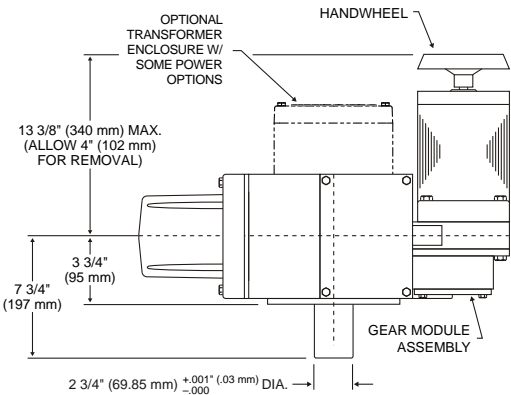
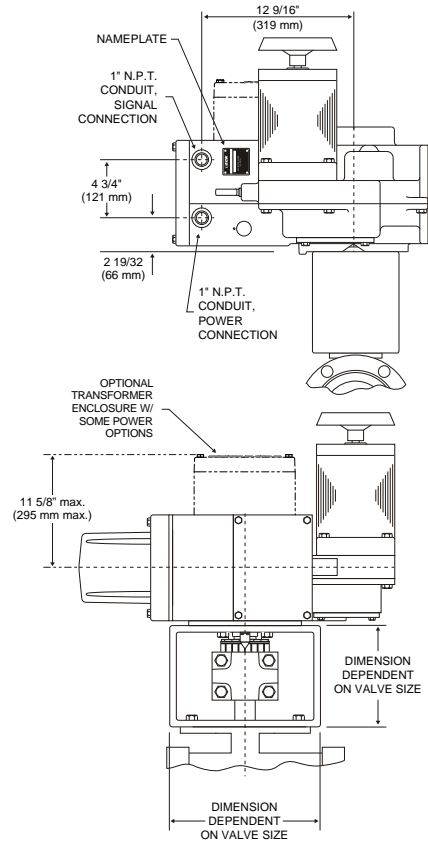
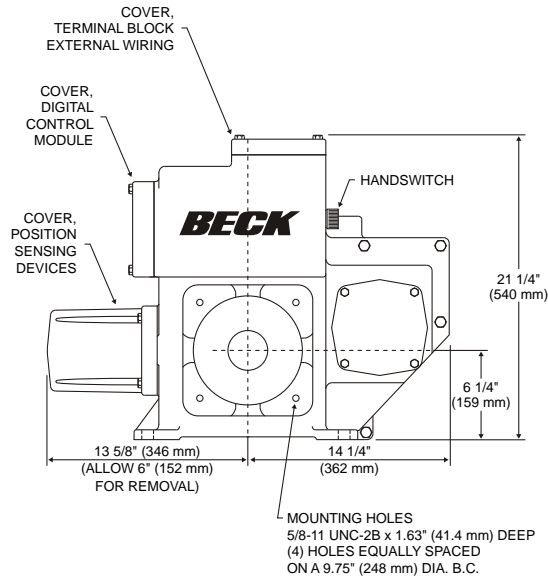

Mechanical Specifications

Crank Arm & Rod End Supplied as Standard							
Beck Actuator Model Number	Approx. Wt. (lbs) [kgs]*	Output Shaft Diameter (in) [mm]	Crank Arm Part Number	Crank Arm Radius "R" (adjustable) (in) [mm]**	Rod End Length "L" Dimension (in) [mm]	Rod End Internal Thread "T" (in) [mm]	Maximum Overhung Load (lbs) [kgs]
11-150	(50) [23]	(.75) [19]	10-3491-05	(1.5 - 5.125) [38 - 130]	(2.125) [54]	(1/2-20 x 1.1875) [1/2-20 x 30]	(750) [340]
11-200	(120) [54]	(1.5) [38]	14-7330-40	(3.5 - 8) [89 - 203]	(2.125) [54]	(1/2-20 x 1.1875) [1/2-20 x 30]	(3,000) [1361]
11-300	(125) [57]	(1.75) [44]	14-8010-34	(3.5 - 8) [89 - 203]	(2.5) [64]	(5/8-18 x 1.5) [5/8-18 x 38]	(4,500) [2041]
11-400	(270) [122]	(2.75) [70]	14-8018-02	(6 - 12) [152 - 305]	(2.875) [73]	(3/4-16 x 1.75) [3/4-16 x 44]	(9,000) [4082]

*Approx. weights are the same for the 11-160, -260, -360 & -460 and their counterparts in the table above.

**Longer or shorter crank arms allowing for a greater or lesser radius are available as an option.

Actuators may be mounted in any orientation.

All dimensions are subject to change. Request certified dimensional drawings for the actuators you select.

OUTLINE DIMENSION DRAWINGS

Model 11-430

Orientation A

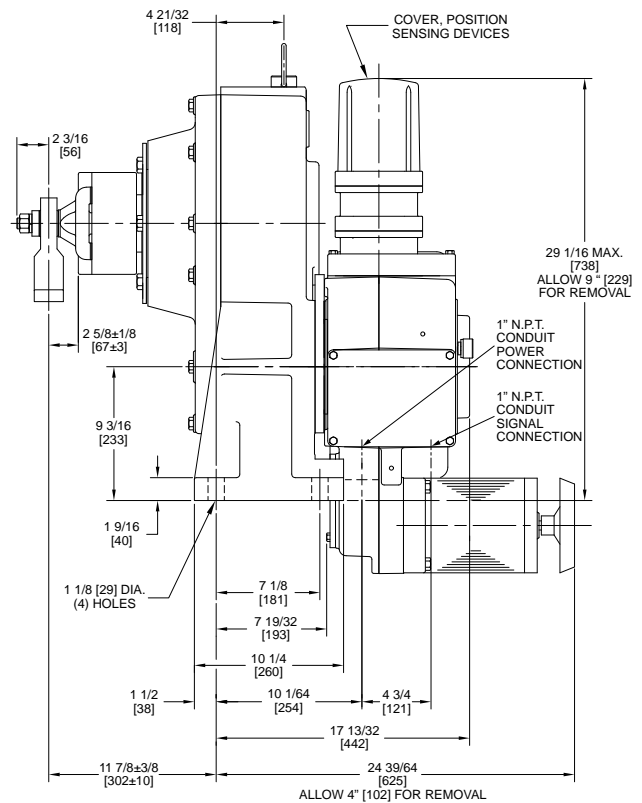
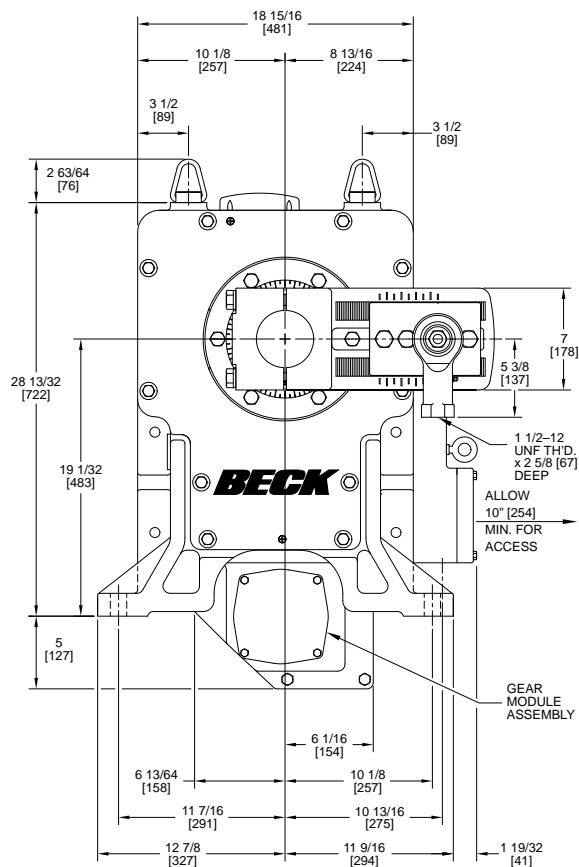

Available Crank Arms

**Standard Crank Arm
(p/n 14-8022-42)**

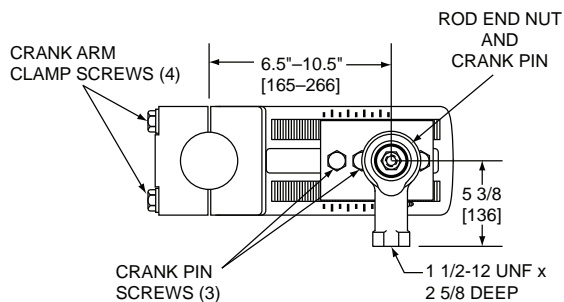

**Alternate Crank Arm
(p/n 14-8022-44)**

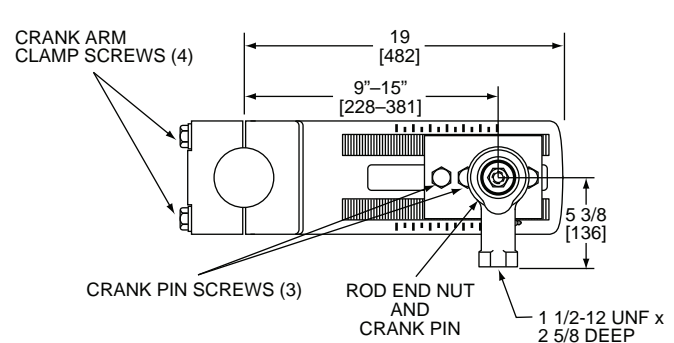

Actuators may be mounted in any orientation.

All dimensions are subject to change. Request certified dimensional drawings for the actuators you select.

Orientation B

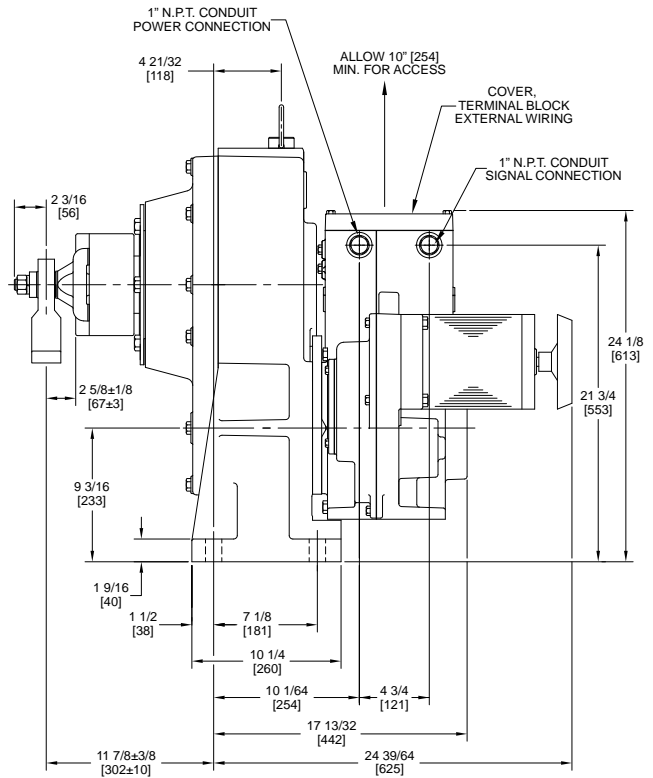
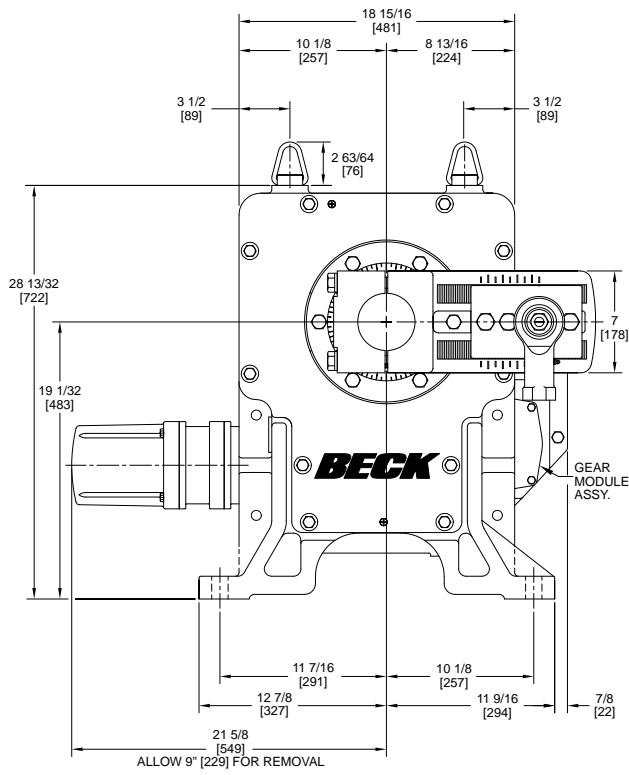

Approx. Wt. (lb) [kg]	Output Shaft Dia. (in) [mm]	Max. Overhung Load (lb) [kg]
790 [358]	3 15/16 [100]	20,000 [9072] Crank Arm 14-8022-42 or 15,000 [6804] Crank Arm 14-8022-44



GROUP 22

HIGH TORQUE DAMPER ACTUATORS

High torque capability in a compact, modular design featuring advanced digital electronics and traditional Beck reliability.

Group 22 damper actuators offer excellent performance in a maintenance-free design, plus the added flexibility and features provided by microprocessor-based electronics.

Ideally suited for large fan damper applications, model 22-309, 22-409 and 22-809 actuators are capable of modulating both static and dynamic loads up to 8,000 lb-ft (10839 N•m) of torque, even in the harshest of environments.

Group 22 installation is simple due to a compact, weatherproof body design which houses all the components, including the advanced control module.



FEATURES

Gear Train

Proven Durability

Beck Group 22 actuators utilize a high-efficiency gear train designed for long life and minimal wear. The precision-cut spur gears are fabricated from heat-treated alloy steel and ductile iron.

Self-Locking Mechanism (SLM)

Back-driving Protection

A Self-Locking Mechanism is an integral part of the Group 22 actuator system. The SLM is a coupling that transmits motor torque to the gear train in either direction, but instantly locks in place when the motor is de-energized; thus preventing back-driving by dynamic loads.

Manual Handwheel

Convenient Local Operation

A manual Handwheel (and Handcrank on model 22-809 drives) is standard on all Group 22 models for use during installation and testing, or during power outages. This Handwheel does not require a declutch mechanism for operation and turns at a safe, slow speed.

Adjustable Crank Arm

Easy Installation and Set up

For ease of installation on any application, the Group 22 crank arm can be easily positioned to start anywhere in the full 360° rotation of the output shaft. To further facilitate proper installation and set up, the crank arm radius is easily adjustable through a wide range of values.

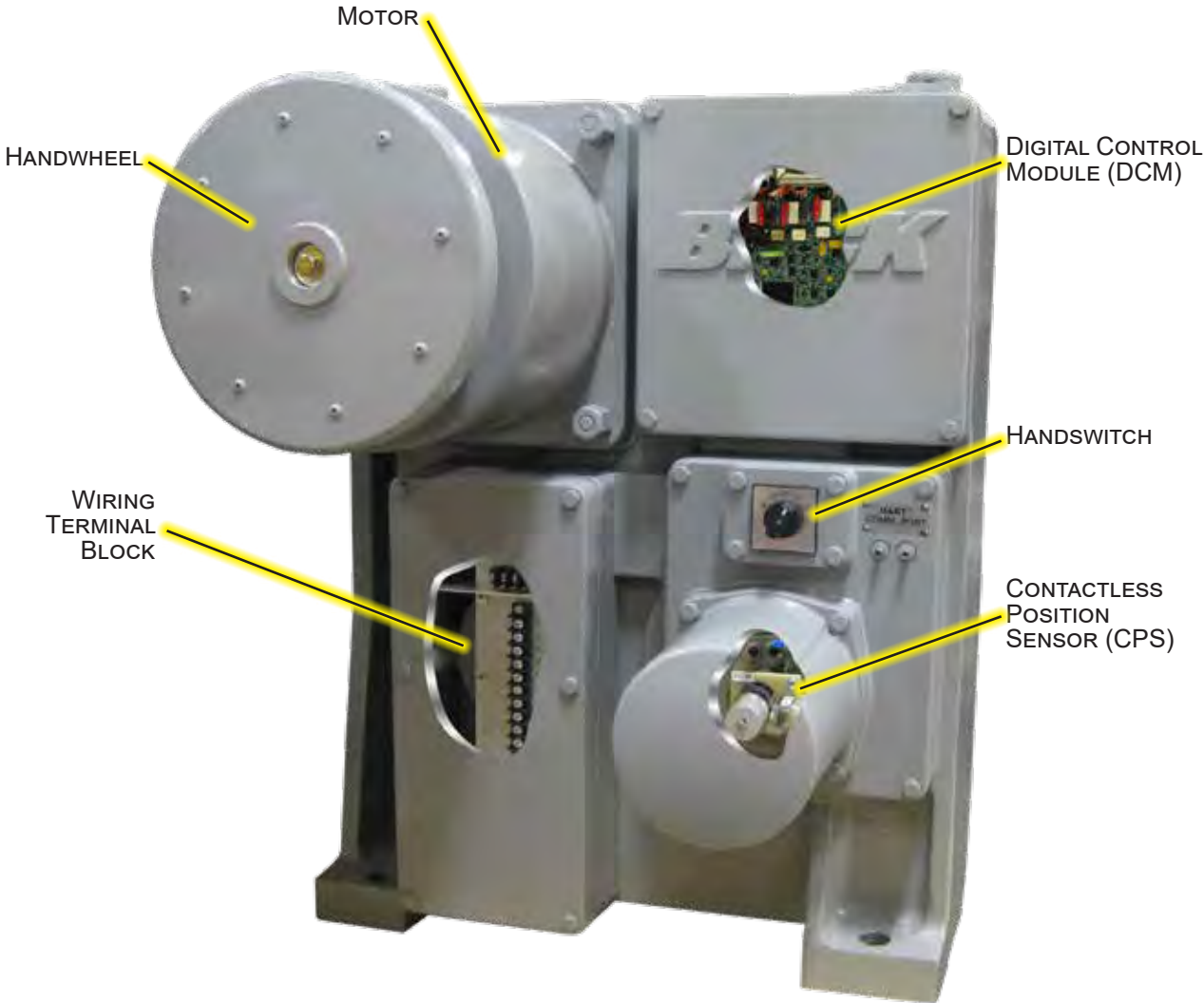

Group 22 Damper Actuator Component Locations (Model 22-309 shown)

Motor

No Burnout

The Beck Group 22 actuator motor design allows for precise control, with low current draw and no duty-cycle limitations. The actuator's onboard control electronics directly feed the motor windings, thus eliminating external motor starters or remote mounted electronics. In addition, the motor does not coast or overshoot and will not overheat—even under continuous modulation.

Live Torque Sensing

The Group 22 includes output torque sensing featuring overtorque protection which will shut the motor off if actuator output torque exceeds 115% of the actuator rating.

Handswitch

Complete Local Control

The Group 22 is equipped with an electrical override Handswitch to aid in set up and installation. It provides local control of the actuator independent of external control signals.

Auxiliary Switches

Easily Adjustable Trip Points

All Group 22 actuators include two non-dedicated SPDT switches, which are cam-actuated directly by the output shaft. Wiring connections are provided in the actuator terminal compartment, allowing for easy access. The switch trip points are easily adjusted in the field to operate at any point in the actuator travel rotation.



Contactless Position Sensor and Auxiliary Switches

State-of-the-Art Design

The Group 22 combines years of experience in actuator design with the latest technologies to provide all of the performance and reliability customers expect from Beck actuators in an even more flexible, powerful and easy-to-use package.

In addition to actuator control, the microprocessor-based electronics provide a host of features and functions. Some of the advanced features include:

- Error-based variable speed operation for precise positioning performance.
- A unique position compensating algorithm and variable speed inverter provide consistent positioning of the actuator down to 0.1° movements.
- Configurable full stroke speeds.
- Two-way digital communications via HART protocol or RS-232 serial connection.
- Live torque measurement and overtorque protection.
- Simplified calibration without any mechanical or electrical adjustment.
- Actuator diagnostics and operating statistics available locally or remotely.
- Stall protection with configurable stall time setting.
- The choice of linear or square input signal characterization.
- Configurable action on loss of demand input signal.
- Easy configuration, set up and documentation of actuator operating parameters.
- All operating parameters including temperature can be displayed via HART.
- Read/write parameters including tag and descriptor information, last calibration date, and model and serial numbers are saved on board.
- Ability to restore all actuator calibration and set up information to the factory “as-built” configuration.
- Compatible with common asset management systems.

CONTROL OPTIONS & SAMPLE WIRING DIAGRAMS

Diagrams are functional—customer wiring may vary. Certified wiring diagrams can be provided for the actuator you select.

Modulating Option 9

Digital Position Control with Contactless Position Sensing

The Beck DCM positions the actuator in proportion to an input current or voltage signal, and the CPS provides integral feedback for the DCM. A 4–20 mA position feedback signal is available for remote indication.

The DCM may be used to provide pre-determined positioning of the actuator upon loss of input control signal.

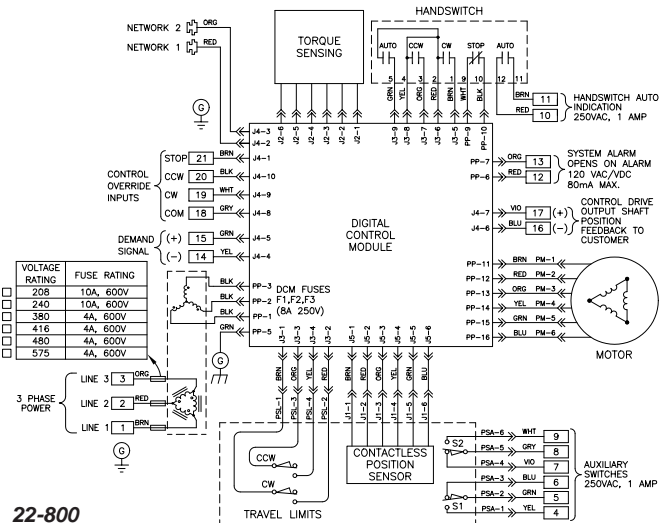
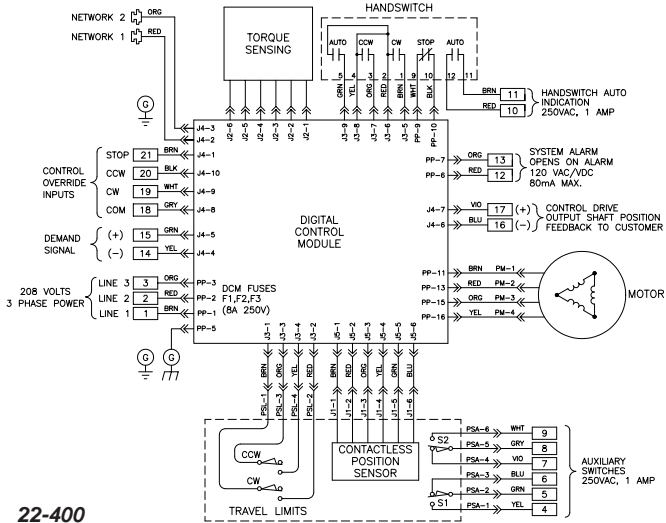
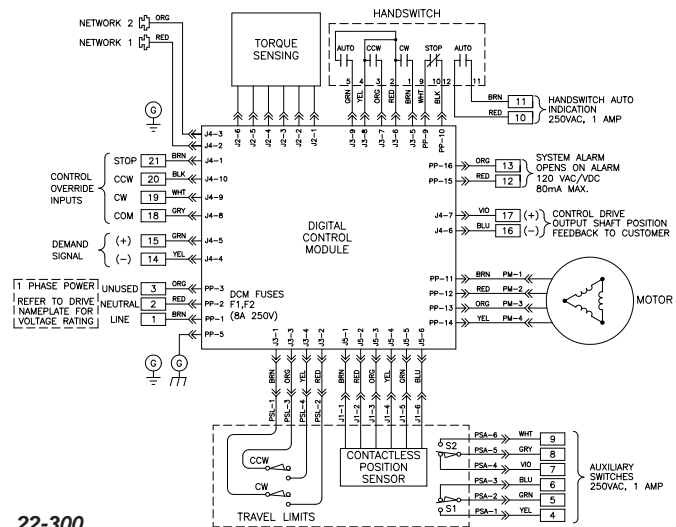

SPECIFICATIONS

Actuator Current Rating in Amps (listed by operating voltage)* / Torque & Timing

Model No.	Operating Voltage (Volts AC)								Output Torque, lb-ft [N•m]	Timing (configurable) sec./100°
	1-phase		3-phase							
	120	240	208	240	380	416	480	575		
22-309	6.0	3.0	3.5	3.0	1.9	1.7	1.5	1.3	3,000 [4 065]	30–300
22-409	N/A	N/A	4.0	3.5	2.2	2.0	1.7	1.4	4,000 [5 420]	15–300
									2,500 [3 387]	10–180
									2,000 [2 710]	08–150
22-809	N/A	N/A	6.9	6.0	3.8	3.5	3.0	2.5	8,000 [10 839]	15–300

*Operating voltage tolerance is +10% to -15%. All models may be operated at 60 Hz or 50 Hz frequency. Standard operating voltage configurations are highlighted. Non-standard operating voltages for the 22-309 & 22-409 are available with an optional transformer.

Weight 22-309, 22-409—540 lbs [245 kgs]; 22-809—1,250 lbs [567 kgs]
Operating Conditions -40° to 85° C. (-40° to 185° F.); 0 to 99% relative humidity
Demand Input Signal Range 4–20 mA, 1–5 Vdc
Communication Protocol HART® Foundation™ technology (standard). Available options: Foundation Fieldbus, Profibus PA
Minimum Step 0.1° typical
Linearity ±1% of span, max. independent error
Hysteresis 0.25% of span at any point
Demand Input Signal Characterization Linear: Actuator output shaft moves proportionally to the input signal. Square: Actuator output shaft moves proportionally to the square of the input signal.
Position Feedback Signal 4–20 mA
Isolation Demand input and position Feedback signals are isolated from ground and the ac power line. Signal buffering provides 24 Vdc isolation between the Demand and Feedback signals.
Overtorque Protection If actuator output torque exceeds 115% of actuator rating, the motor will shut off (feature can be enabled / disabled).
Action on Loss of Input Signal (Power On) Stays in place or runs to any preset position (configurable).
Stall Protection (protects actuator and driven elements under stall conditions) If the motor tries to run in one direction for more than 300 seconds (configurable from 30–300), motor will shut off.
Over-travel Protection Switches (Dedicated) Two Form C, one for CW and one for CCW limit of output shaft travel. Standard switch setting allows 100° of travel.
Auxiliary Switches (Non-dedicated) Two Form C, rated for 1 A, 250 Vac—cam operated and field adjustable.
Handswitch Permits local electrical operation, independent of Demand input signal.
Handwheel (and Handcrank on the 22-809) Provides manual operation without electrical power.
Enclosure Precision-machined, aluminum alloy castings painted with corrosion-resistant polyurethane paint provide a rugged, dust-tight, weatherproof enclosure. Type 4, 4X; IP66.
Standards UL Listed; CE Compliant <i>Note: For standards not specifically listed, please call Beck for more information at 215-968-4600.</i>
Mounting Orientation Upright, as depicted in outline dimension drawings.

OUTLINE DIMENSION DRAWINGS

Model 22-309/-409

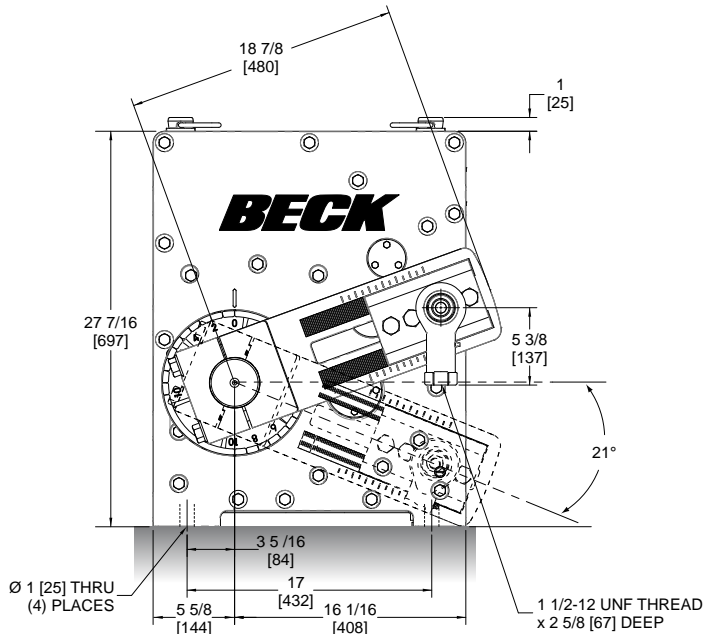

Front View

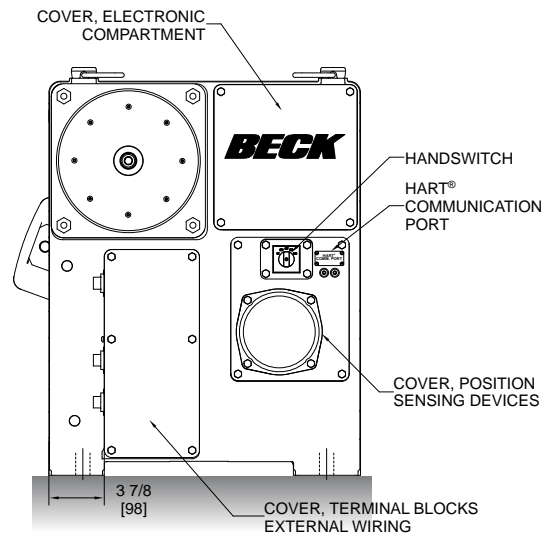

Rear View

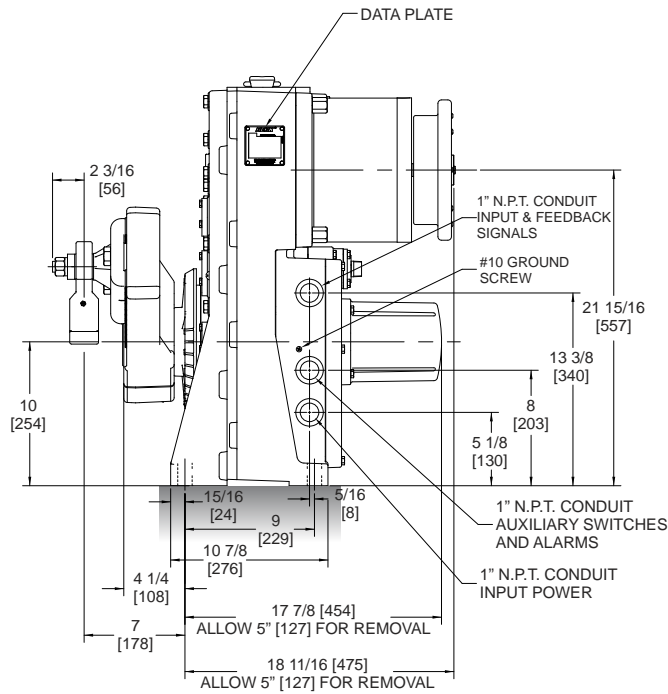

Side View

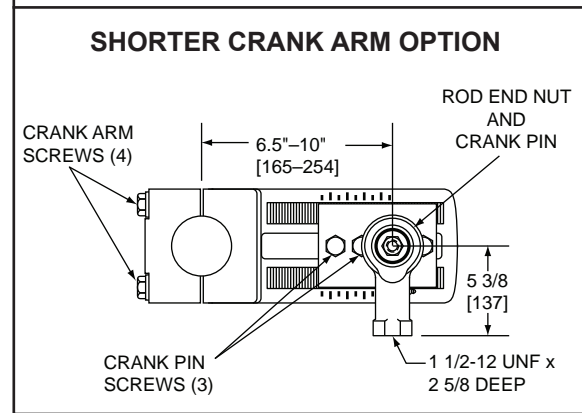
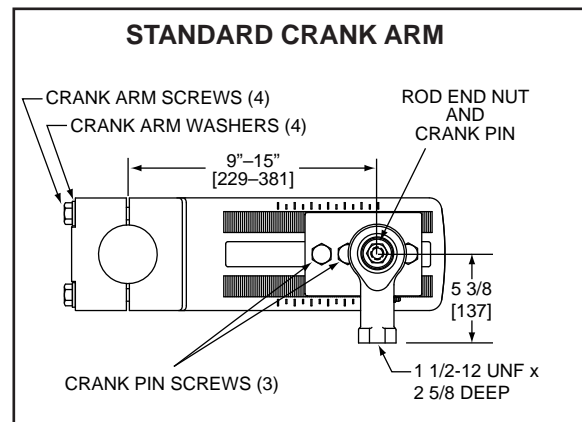

Mechanical Specifications

Model No.	Torque, lb-ft [N•m]	Timing sec./ 100°	Approx. Weight, lbs [kgs]	Output Shaft Diameter, in [mm]	Max. Overhung Load, lbs [kgs]
22-309	3,000 [4065]	30-300	540 [245]	3.5 [89]	15,000 [6804]
22-409	4,000 [5420]	15-300	540 [245]	3.5 [89]	15,000 [6804]

Model No.	Torque, lb-ft [N•m]	Timing sec./ 100°	Approx. Weight, lbs [kgs]	Output Shaft Diameter, in [mm]	Max. Overhung Load, lbs [kgs]
22-409	2,500 [3387]	10-180	540 [245]	3.5 [89]	15,000 [6804]
22-409	2,000 [2710]	08-150	540 [245]	3.5 [89]	15,000 [6804]

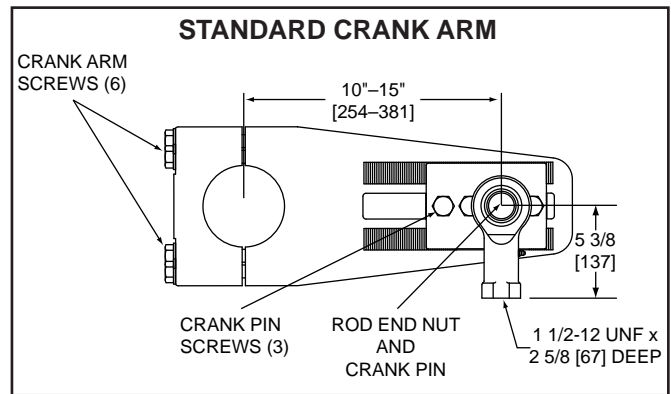
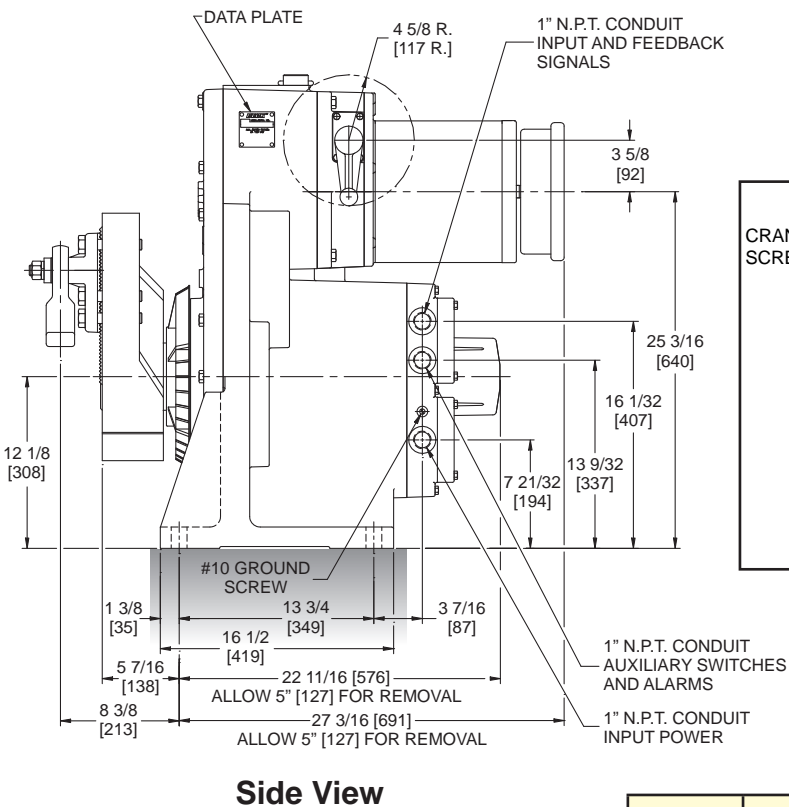
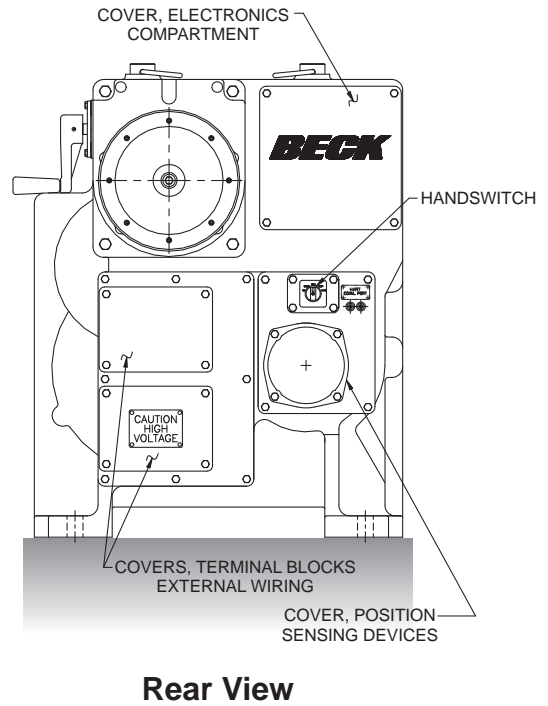
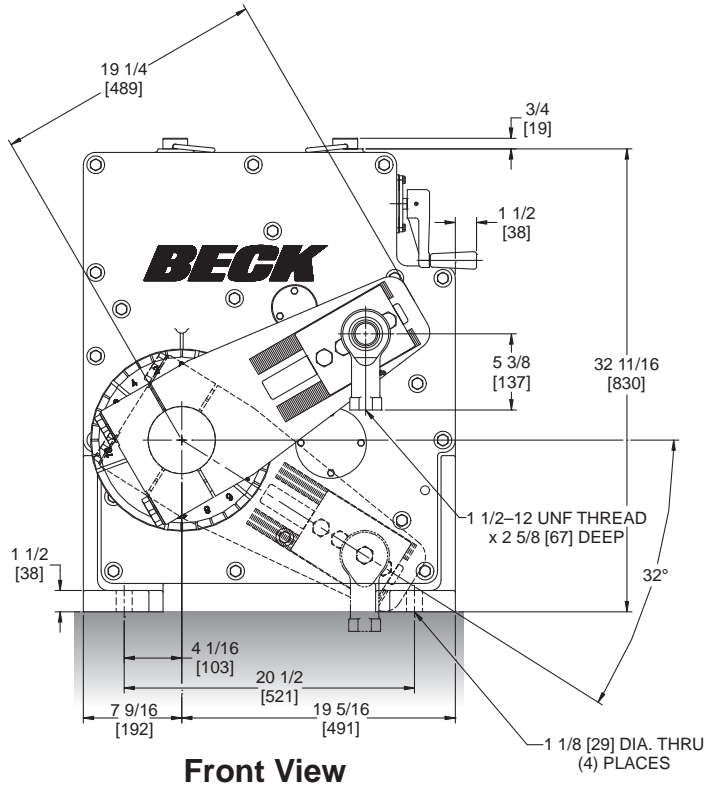

Mechanical Specifications

Model Number	Torque, lb-ft [N•m]	Timing sec./100°	Approx. Weight, lbs [kgs]	Output Shaft Diameter, in [mm]	Max. Overhung Load, lbs [kgs]
22-809	8,000 [10839]	15-300	1,250 [567]	(4.75) [121]	(30,000) [13608]

All dimensions are subject to change.

Request certified dimensional drawings for the drives you select.

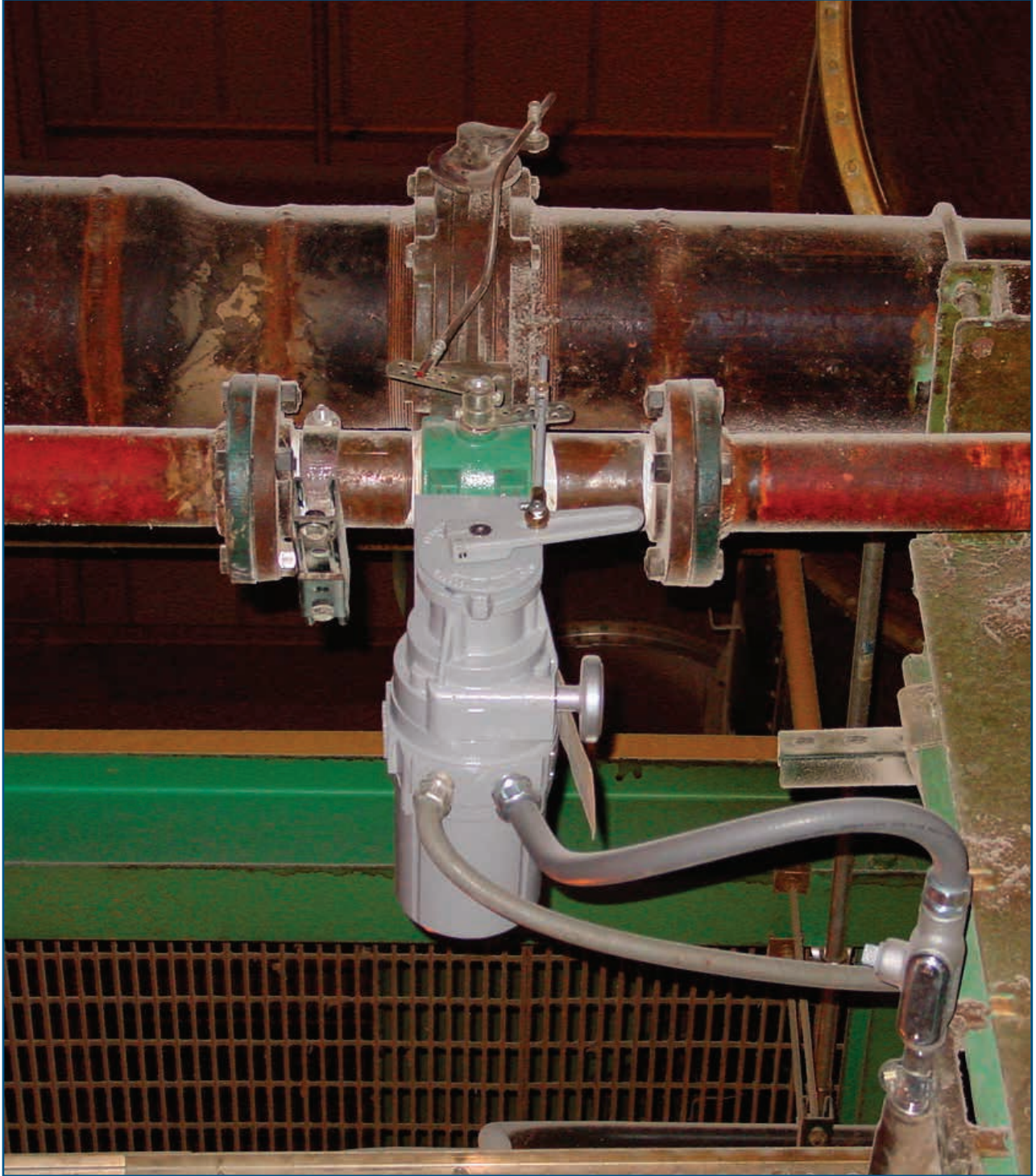

GROUP 31

COMPACT ACTUATORS FOR LOW TORQUE DAMPER AND VALVE APPLICATIONS

High reliability and responsiveness in a small package.

The Group 31 actuator is designed for coupling to small quarter-turn ball and butterfly valves.

Its compact in-line design consists of an output section housing the drive train and motor, and a control module section containing the electronics. Together, these two sections provide an enclosure designed to meet Type 4 specifications for protection against corrosion, dust and moisture. A design that meets Type 7 specifications is also available.

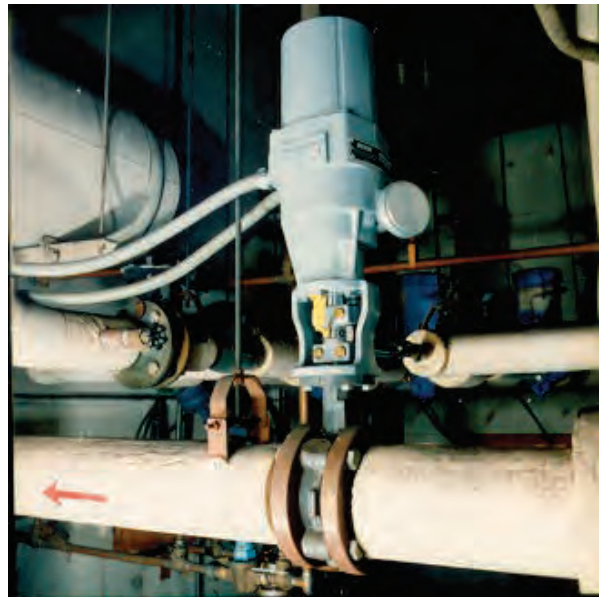

The Group 31 incorporates the same type of motor used in Beck's Group 11 and Group 14 drives, which provides millisecond response to signal commands in a modulating control loop. This no-burnout, non-coasting motor is capable of more than 60 starts per minute during process upsets and will remain cool and stable during operation for unparalleled online performance.

FEATURES

Motor and Drive Train

Unequaled Availability

Beck's Group 31 rotary actuators incorporate an exclusive no-burnout motor, so that online dependability of valves is ensured. Heat-treated alloy steel and ductile iron hypocycloidal gearing transmits torque smoothly and powerfully to the output shaft. The Beck-built control motor provides millisecond response to signal commands in a modulating control loop—eliminating the coasting and overshooting problems typical of outdated electric actuators.

The motor stator of the Group 31 actuator is molded into the centerpiece, providing stable delivery of torque without overheating and without burning out.

Mechanical Stops

Protection from Overtravel Damage

Rugged mechanical stops are furnished as a standard component of the valve mounting assembly. These stops prevent over-travel damage to valves and limit drive travel during manual cycling to maintain proper orientation of the drive output shaft with respect to switches and controls. A built-in position indicator shows the valve position.

Manual Handwheel

Convenient Local Operation

A manual Handwheel is standard on all Group 31 models for use during installation and testing, or during power outages. This Handwheel does not require a declutch mechanism for operation and does not rotate during automatic operation.

Electronic Control Module

Accurate Position Control

Group 31 Analog Modulating actuators include a single electronic control module which receives a 4–20 mA or 1–5 Vdc input signal and provides a 4–20 mA or 1–5 Vdc feedback for position control and indication.

- Electronic module has a deadband of 1.0% of span with sensitivity of 25% of deadband.
- The input signal span is nominally adjustable from 50% to 125% of the 4 V span, with the zero adjustable up to 120% of span, providing flexibility for split range operation.

Limit & Auxiliary Switches

Four cam-operated switches are included as part of the control module. Two switches open the motor circuit and function as end-of-travel limit switches, and two auxiliary switches are for external signaling as required by the user. The switch cams are driven directly by the actuator's output shaft for accurate control.

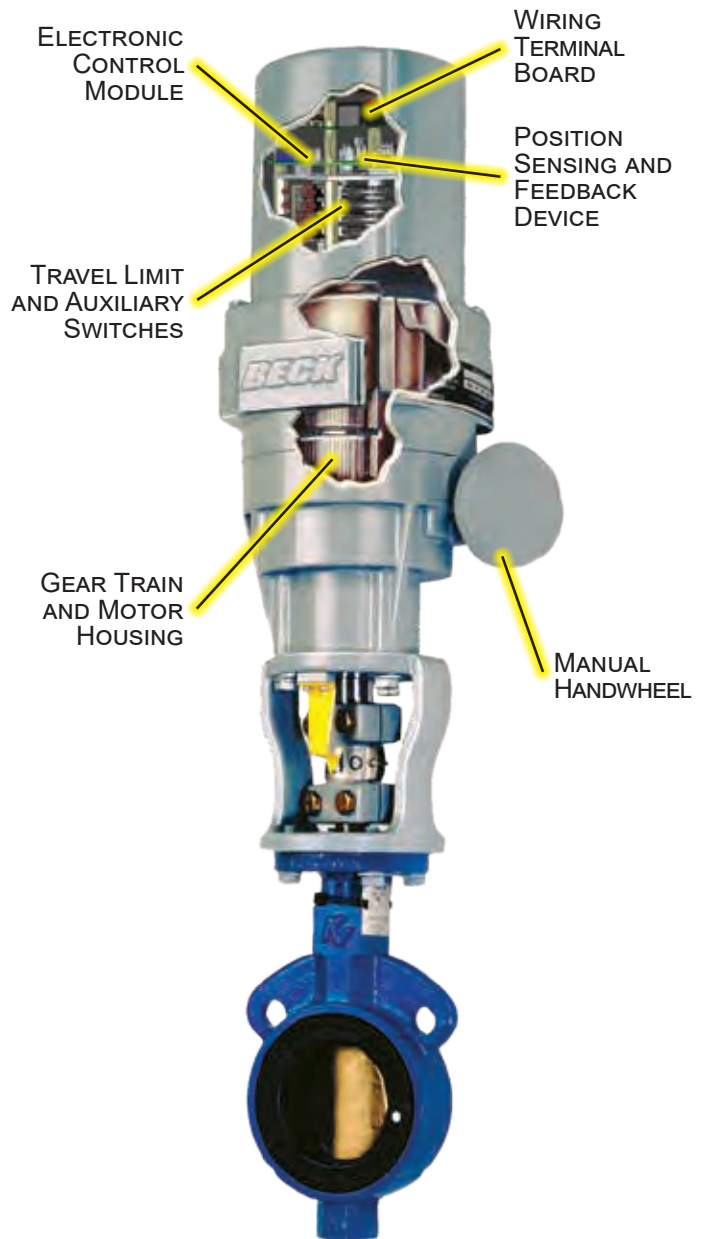

Group 31 Rotary Actuator Components

Electric Handswitch

Convenient Local Operation

Included in the Analog Modulating models is an integral electric Handswitch, which permits safe, local operation at the valve's individual location. This feature saves time during installation and allows adjustments to be made quickly and easily.

Large Terminal Block

Easy Field Wiring

The upper board on the Group 31 actuator provides wiring terminals for field connection. This board is easily accessible to minimize time needed for installation wiring and testing.

Position Feedback

Beck Group 31 actuators equipped with feedback capability use a film potentiometer incorporated into the control module.

All modulating models feature electronic position indication. Direct AC models allow controllers to monitor drive position as the controller output directly positions the drive. Analog control modulating models provide electronic signal receiver circuitry, which compares the position indication to the control loop demand signal and provides automatic control.

Dual Feedback Capability

All models incorporating the film potentiometer have dual feedback capability, permitting user choice of 2-wire or 4-wire field connection.

- 2-wire systems for 4–20 mA feedback, as follows.

Either:

300 ohm max. load resistance, which requires less than 35 Vdc external power supply.

or:

Up to 800 ohm max. load resistance, which requires greater than 36 Vdc external power supply.

- 4-wire systems utilizing 120 Vac power supplied to the actuator.

Either:

4–20 mA feedback,

500 ohm max. load resistance.

or:

1–5 Vdc feedback,

12,000 ohm min. load resistance.

Connections for feedback selection are made in the field and need not be specified on order.

Low Power Consumption for Use with Uninterruptible Power Supplies

The uniquely low power draw of Beck Group 31 actuators permits the use of various standard uninterruptible power supplies for operation during loss of AC power. Beck Sales Engineers can provide you with specifications on UPS equipment recommended for Beck drives.

Direct-Coupled Configurations

The Group 31 actuator may be coupled directly to the valve by the use of a factory machined, heat-treated coupling. This configuration is compact in design. A factory designed yoke between the actuator and the valve provides rigidity and accessibility to mounting hardware.

Crank Arm / Linkage Configurations

For applications requiring linkage connection, Beck Group 31 actuators can be furnished with a machined crank arm and mounting bracket. Beck hex linkage kits may be used to simplify final connections.

Factory Mounted Assemblies

The relationship of valve, actuator and mounting / coupling configuration can be of critical importance in ensuring a successful installation. For this reason, Beck provides Group 31 actuators and valves together—factory mounted and tested for simple drop-in installation. These fully integrated, unitized assemblies are pre-engineered to match the mechanical and electronic requirements of your system.

CONTROL OPTIONS & SAMPLE WIRING DIAGRAMS

Diagrams are functional—customer wiring may vary. Certified wiring diagrams can be provided for the drive you select.

Option 3, Modulating

Analog Position Control with Drive Powered Position Feedback Signal

Customer must supply two wires to power the drive: One 120 Vac line (terminal 1), and one neutral (terminal 2). Customer must supply two wires for analog control: Connect to terminal 11 (-) and to terminal 12 (+). Customer may supply two additional wires to monitor the analog position feedback signal: Connect to terminal 13 (-) and to terminal 14 (+). The drive's feedback circuit power supply is derived from the 120 Vac line, therefore the feedback signal must be wired to a "4-wire" type, non-powered analog input.

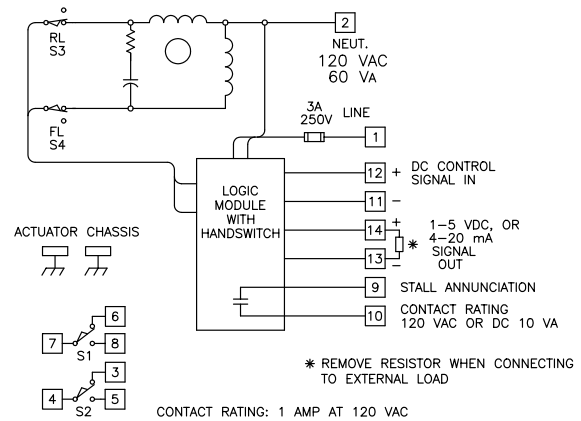

Analog Position Control with Loop Powered Position Feedback Signal

Customer must supply two wires to power the drive: One 120 Vac line (terminal 1), and one neutral (terminal 2). Customer must supply two wires for the analog input control signal: Connect to terminal 11 (-) and to terminal 12 (+). The loop powered position feedback signal must be connected to a "2-wire" type analog input that provides a dc voltage over the signal wires (a dc voltage power supply must be wired in series with the signal wiring). If the dc supply is 24 to 35 volts, connect to terminal 14 (-) and to terminal 15 (+). If the dc power supply is 36 to 45 volts, reverse polarity and connect to terminal 14 (+) and to terminal 15 (-).

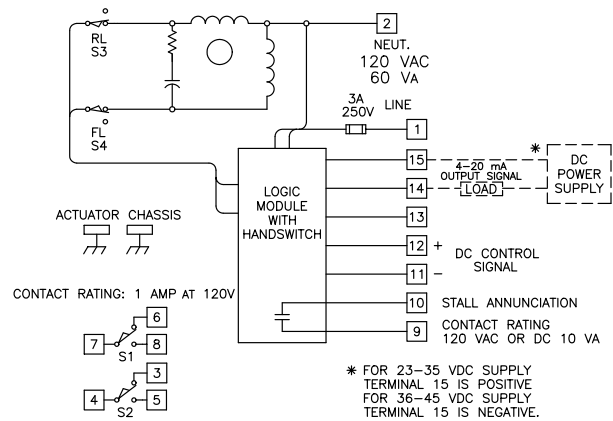

Option 2, Modulating

Direct AC Control with Loop Powered Position Feedback Signal

Customer must supply three wires to directly control the drive motor direction: One 120 Vac line to run Forward (terminal 10), one 120 Vac line to run Reverse (terminal 9), and one neutral (terminal 2). Customer may supply two additional wires to monitor a loop powered position feedback signal. The loop powered position feedback signal must be connected to a "2-wire" type analog input that provides a dc voltage over the signal wires (a dc voltage power supply must be wired in series with the signal wiring). If the dc supply is 24 to 35 volts, connect to terminal 14 (-) and to terminal 15 (+). If the dc supply is 36 to 45 volts, reverse polarity and connect to terminal 14 (+) and to terminal 15 (-).

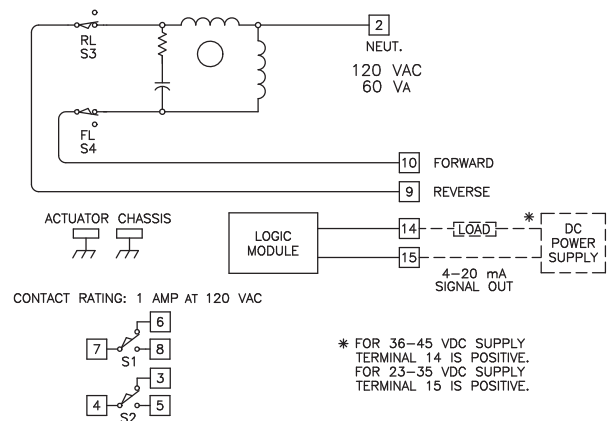

Option 2, Modulating (con't)

Direct AC Control with Drive Powered Position Feedback Signal

Customer must supply three wires to directly control the drive motor direction: One 120 Vac line to run Forward (terminal 10), one 120 Vac line to run Reverse (terminal 9), and one neutral (terminal 2). Customer may supply two additional wires to monitor the analog position feedback signal: Connect to terminal 13 (-) and to terminal 14 (+). If position feedback monitoring is desired, a 120 Vac line must be connected to terminal 1. The drive's feedback circuit power supply is derived from this 120 Vac line, therefore the feedback signal must be wired to a "4-wire" type, non-powered analog input.

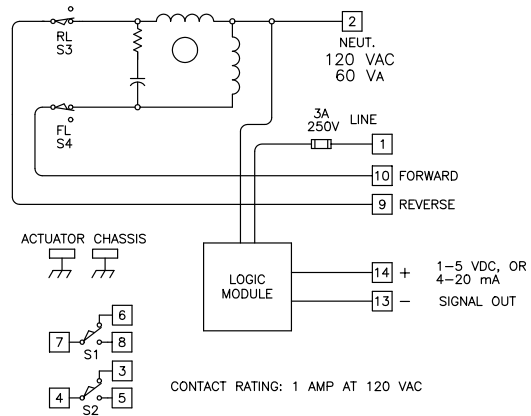

Option 1, Open/Close

Direct AC Control

Customer must supply three wires to directly control the drive motor direction: One 120 Vac line to run Forward (terminal 10), one 120 Vac line to run Reverse (terminal 9), and one neutral (terminal 2).

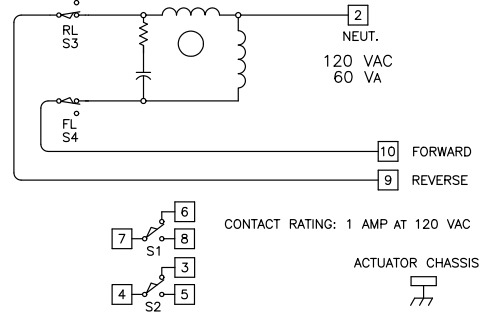

SPECIFICATIONS

Control Options, Torque and Timing

Model Number	Control Option	Control Mode	Input Signal	Feedback Signal	Auxiliary Switches	Torque lb-ft [N•m]	Timing (sec./90°) 60 Hz ¹
31-M30 31-M50	3	Modulating (Analog Position Control)	4–20 mA 1–5 Vdc	4–20 mA 1–5 Vdc	2	15 [20] 30 [41]	18 24
31-330 31-350	2	Modulating (Direct AC Control)	120 Vac	4–20 mA 1–5 Vdc	2	15 [20] 30 [41]	18 24
31-230 31-250	1	Open / Close Operation	120 Vac	None	2	15 [20] 30 [41]	18 24

¹50 Hz timing data does not exceed 120% of 60 Hz levels.
Maximum drive current is 0.5A.

<p>Input Power 120 Vac, single-phase 50 or 60 Hz, 0.5 amp, 60 watts</p>
<p>Operating Conditions –40° to 65°C (–40° to 150°F)</p>
<p>Action on Loss of Power Stays in place.</p>
<p>Control Types <u>Milliamp modulating (Control Option 3)</u>—Differences between the Feedback signal and Input signal are amplified, activating the electronic output switch necessary to drive the motor in the proper direction to force the signal differential to zero. <u>120 Vac contact closure (Control Options 1 & 2)</u>—Motor is energized by 120 Vac line current from a remote controller or manual switches.</p>
<p>Deadband 1.0% of Span</p>
<p>Sensitivity .2% of Span</p>
<p>Action on Loss of Input Signal (Option 3) Stays in place or moves to a predetermined position with ac power supplied.</p>
<p>Action on Stall (Option 3) Relay contacts open after 68 seconds of stall, remote signal available. Power to motor is turned off.</p>
<p>Enclosure Precision machined aluminum alloy castings, painted with corrosion resistant polyurethane paint. Rated Type 4, IP66.</p>
<p>Standards CSA Labeled (US & Canada); CE Compliant <i>NOTE: For standards not specifically listed, please call Beck for more information at 215-968-4600.</i></p>
<p>Hazardous Locations (Optional) Class I, Div.1, Group D; Class I, Div.2, Group D; Class II, Div. 1, Groups E, F & G; Class II, Div.2, Groups F & G; Class III, Div.'s 1 & 2. <i>NOTE: May not be available with all options & models. If these ratings do not meet your requirements, call Beck at 215-968-4600.</i></p>

OUTLINE DIMENSION DRAWINGS

Basic Actuator

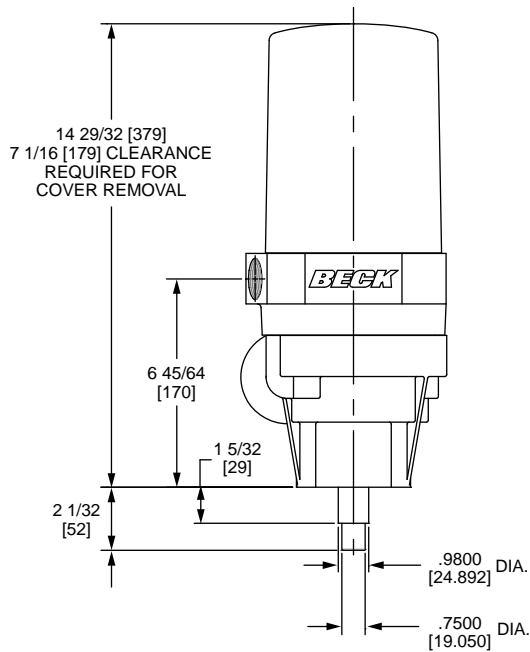

MOUNTING HOLES
3/8-16 UNC-2B x 7/8 [22] DEEP
TYP. (3) PLACES HOLES EQUALLY
SPACED ON 3 3/8 [86] B.C.

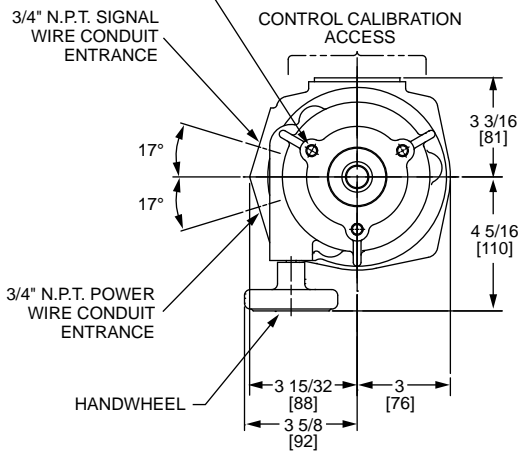

Mounting Option A

Yoke Mounting with coupling connection and mechanical stop

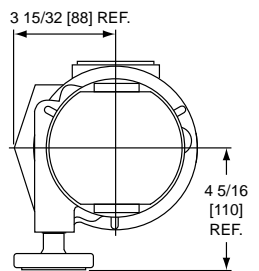
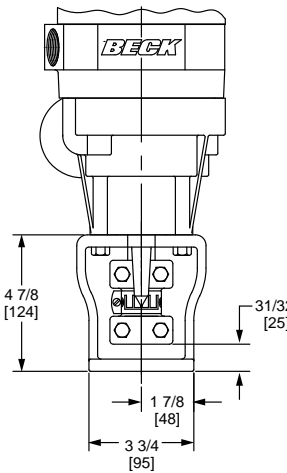

BOLT HOLE PATTERN AND SHAFT THROUGH HOLE DIMENSION MUST BE SPECIFIED PER APPLICATION

Mounting Option B

Bracket mounting with crank arm assembly and mechanical stop

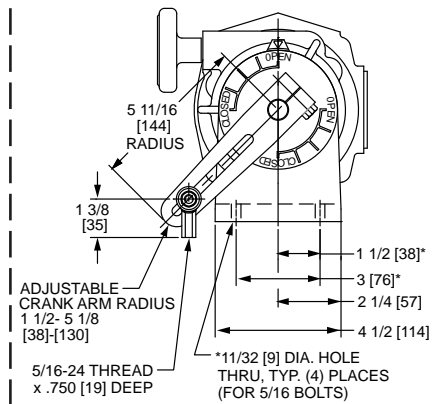
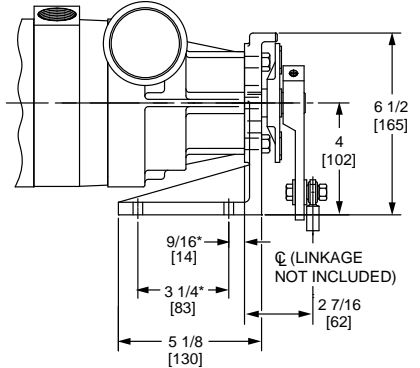

*STANDARD BRACKET CAN BE SUPPLIED WITHOUT HOLES OR HOLE PATTERN SHOWN.

Mounting Option C

Basic actuator with crank arm assembly and mechanical stop

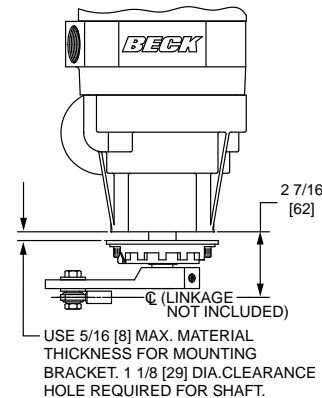

Mounting Option D

Basic actuator with mechanical stop

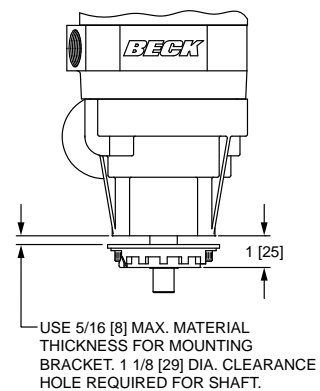

Mechanical Specifications

Beck Drive Model	Approx. Wt. lbs [kg]	Max. Overhung Load lbs [kg]
Group 31	36 [16]	500 [227]

Drives may be mounted in any orientation.

All dimensions are subject to change. Request certified dimensional drawings for the drives you select.



GROUP 57

AC/DC powered quarter-turn valve actuators

Ideally suited for remote applications where AC line power is not available and/or fail-to-safe position response is required.

The Group 57 actuator has features designed to meet the requirements found in many remote and hazardous locations—such as wellhead and pipeline valves in the oil and gas industry.



Features and advantages specific to the Group 57 include:

- **The ability to run on 12–48 Vdc power**, making the Group 57 ideal for use with solar panel operation.
- **Class I, Division 1, Groups B, C & D hazardous location ratings.**
- **Built-in electric fail-safe capability** with optional, internal ultra-capacitor backup power.
- **Fast stroking speeds (9 seconds for 90°)** for applications with fast open or close requirements (adjustable).
- **Simple and flexible valve mounting options** including compliance with the ISO 5211 Part-turn Actuator Mounting Standard or custom hardware to fit virtually any valve.
- **Space efficient packaging** making it easier to fit on valves in any orientation.

FEATURES

Beck Motor

Compact, Reliable Control & Uniquely Fast

The compact Beck motor provides powerful, reliable performance.

- **Never overheats or burns out**, even under demanding modulating control or stalled conditions.
- Starts and stops instantaneously—eliminating deadtime.
- Travels 90 degrees in 9 seconds.
- Provides extremely accurate positioning in modulating applications.
- **Will not coast or overshoot** the desired position.
- Low power draw eliminates the need for relays. Very efficient when used with the optional, internal backup power supply.
- Maintenance-free with double-lipped, grease-sealed bearings.

Lockable, Electric Handswitch

Time-Saving Local Operation

Valves may be operated at their individual locations with the built-in, lockable, electric Handswitch. This saves time during installation and troubleshooting, allowing online adjustments to be made quickly and easily by bypassing the electronics in the actuator and control system.

The Handswitch also serves as an electrical backup in the event of control system failure.

The Handswitch may also be locked in the AUTO position to prevent local operation.

Over-travel Limit Switches & Auxiliary Switches

Two over-travel protection limit switches are provided and up to four additional auxiliary switches are available as an option. Switch features include:

- Rated for a minimum of 6 A at 120 Vac to ensure long life.
- Field-adjustable to operate at any point in the actuator's travel range.
- May initiate secondary functions or provide remote indication of actuator position.
- Eliminates unreliable and maintenance-intensive proximity switches.

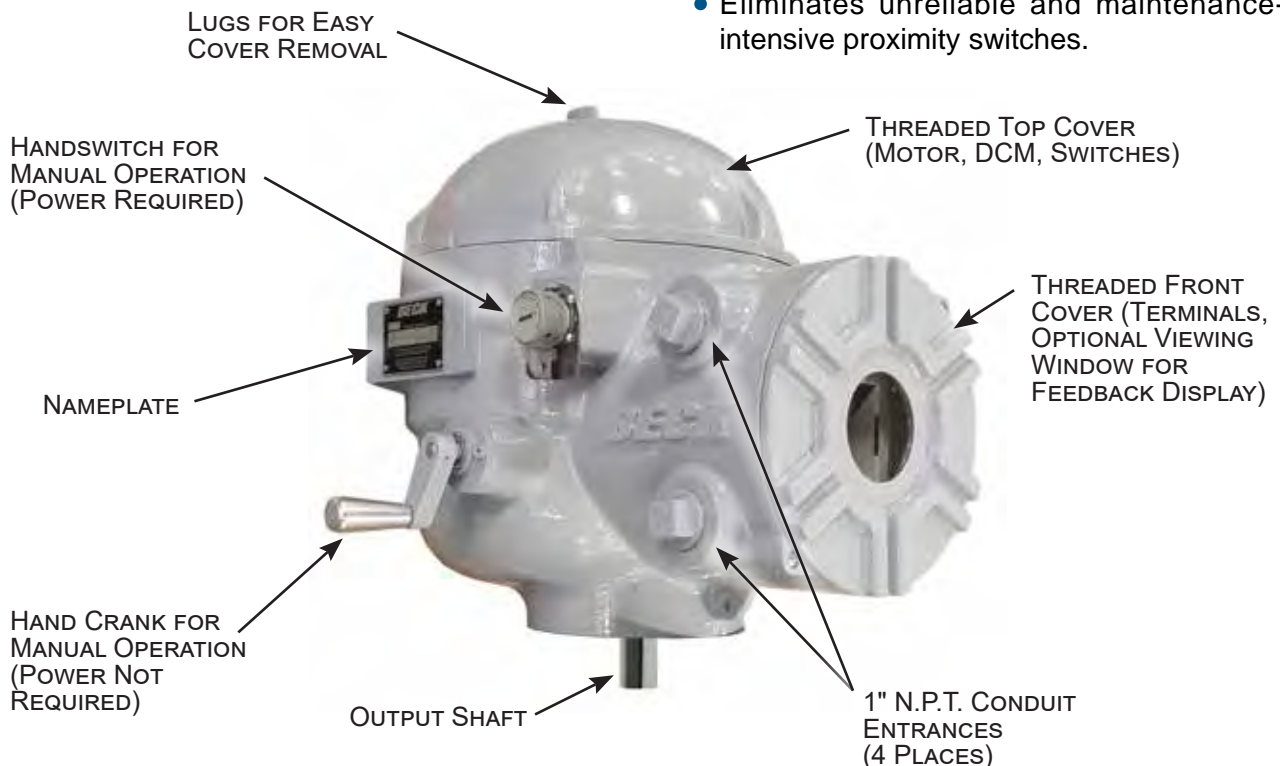

Group 57 Actuator Component Locations

Feedback Display (optional)

Actuator position at a glance

The feedback display is an illuminated, numerical readout showing the actuator's position as a percentage of full travel. The display is viewed through a tempered glass window in the terminal compartment.

Three LEDs are visible through the window. Two configurable LEDs light at either end of actuator travel—a red LED and a green LED. A yellow LED lights when the actuator is moving toward either end of travel.

Drive Train

Power and Durability that Maximize Reliability and Minimize Maintenance

Beck's durable gear train maintains accurate, consistent valve positioning even under the demanding conditions of an active control loop.

- Gear trains are constructed of heat-treated alloy steels and ductile iron.
- Efficient gearing essentially eliminates wear-induced backlash and positioning inaccuracies.
- Durable design provides up to 4 days of protection against intermittent or extended accidental stalls.
- Integral self-locking mechanism ensures that actuators hold a minimum of 200% of rated torque with the motor de-energized.

Hand crank

Manual Control Without Declutch

An easy-to-turn Hand crank is incorporated into the Group 57 design to allow manual operation during installation or power outages.

- The hand crank can be used to move valves to any position smoothly and easily under full load conditions.
- Mechanical stops prevent manual overtravel.

Housing

Superior Protection and Convenient Access to Components

Beck actuators feature a cast aluminum body with compartments to protect components from moisture and dirt, and allow easy access for installation and calibration.

- Precision-machined aluminum alloy castings with corrosion-resistant poly-urethane paint provide a rugged, dust-tight, weatherproof Type 4X enclosure.
- Specifically designed for use in Hazardous classified locations—Class I, Division 1, Groups B, C & D.
- The top compartment protects the motor, electronics and switches. A separate, sealed compartment protects the terminals and display.
- Gasketed, precision-machined, threaded covers provide extra protection for harsh environments.
- Output and hand crank shafts use double-lip seals to ensure lifelong protection from harsh environments.

Mounting Versatility

Can be Mounted in any Orientation for Greater Installation Flexibility

Group 57 actuators are lubricated in such a way that they may be mounted in any convenient position. This flexibility allows actuators to be installed in hard-to-fit locations.

Mounting orientation is limited only by the accessibility of the housing compartments.

SAMPLE WIRING DIAGRAM & SPECIFICATIONS

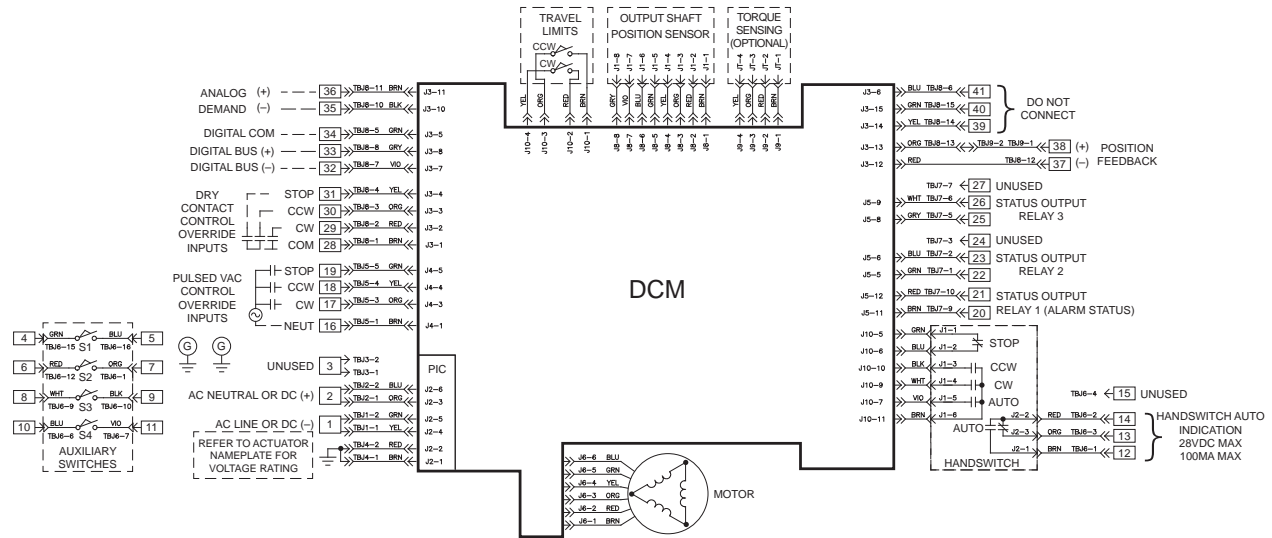

<p>Power 12–30 Vdc (standard). Optional variants: Extended range DC (12–48 Vdc); AC transformers (120, 208, 240, 380, 415, 480, 575 Vac).</p>
<p>Torque Output 120 lb-ft (162.7 N•m).</p>
<p>Stroke Timing 9 seconds per 90° (configurable for slower speeds).</p>
<p>Positioning Resolution (Minimum Step Size) 0.1° typical. Configurable from 0.1° to 2.25°.</p>
<p>Weight Approximately 59 lbs. (27 kgs.).</p>
<p>Certifications Ordinary & Hazardous Locations available: Class I, Division 1, Groups B, C & D and Class II, Division 1, Groups E, F & G. Enclosure ratings: Type 4X; IP66/IP68 at 3 meters for 48 hours.</p>
<p>Environmental Temperature Rating -50°C to 85°C (-58°F to 185°F) (may vary depending on options).</p>
<p>Control Input 4–20 mA signal or ac/dc pulses.</p>
<p>Communication Interfaces HART and Modbus RTU (standard); Modbus TCP (optional)</p>
<p>Configuration Options Local pushbuttons, RS-232 Serial command port, Device Description (DD) based HART tools, Modbus.</p>
<p>Modulation Duty 100% continuous duty with no limitations.</p>
<p>Mounting Orientations Actuator may be mounted in any orientation without restrictions.</p>
<p>Manual Operation Hand crank (no power required) and Handswitch (power required).</p>
<p>Switches and Relays (2) cam-operated over-travel protection switches (standard); up to (4) Form C auxiliary, cam-operated switches (optional); (1) SS alarm; (2) programmable SS SPST relays (standard) or (2) mechanical DPDT relays (optional); status relay (standard).</p>
<p>Wiring and Termination Easy access, screw-type terminals accept up to 12 AWG wire.</p>
<p>Hard Stops Internal, fixed (standard); external adjustable hard stops (optional).</p>
<p>Status Indications Configurable LEDs (red, green and yellow) visible through optional terminal compartment window; digital numeric LED position display available (only if ordered with optional terminal compartment window).</p>
<p>External Position Feedback Signal 4–20 mA or 1–5 Vdc signal (standard).</p>
<p>Backup Power Supply (Optional) An internal backup supply utilizing ultra-capacitors to provide “go-to-position” response upon power loss; maximum operating temperature limitations apply.</p>
<p>Valve Mounting Hardware (Optional) ISO 5211 compatible hardware or custom hardware.</p>

OUTLINE DIMENSION DRAWINGS

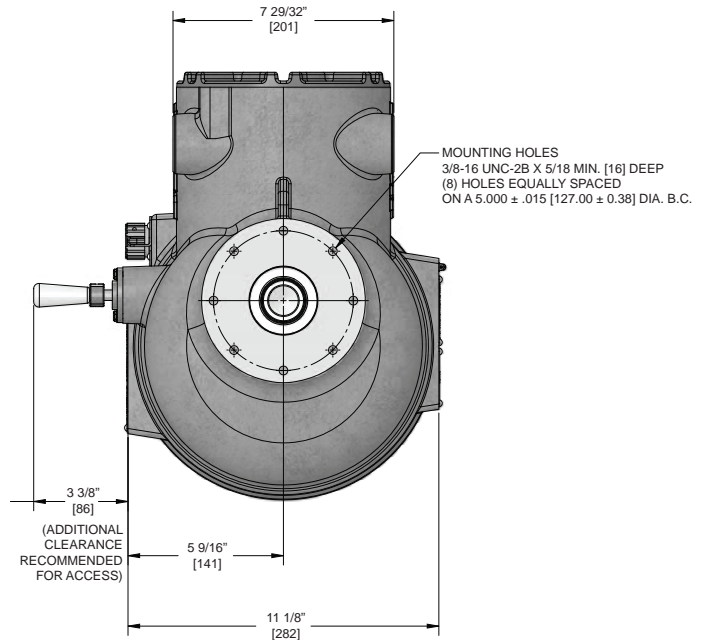
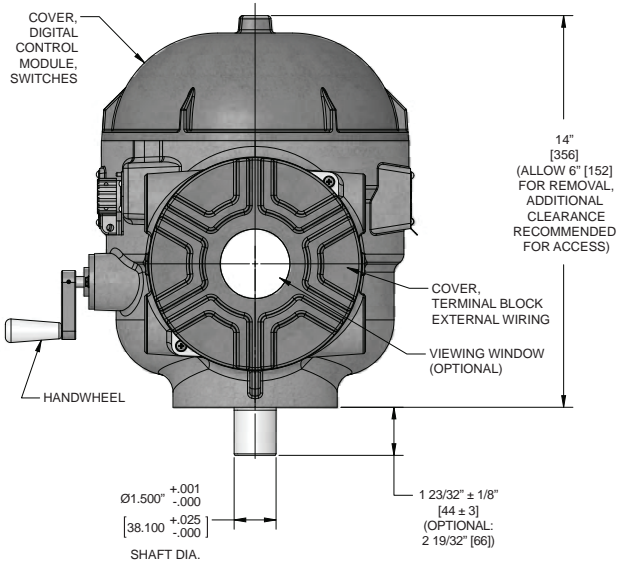
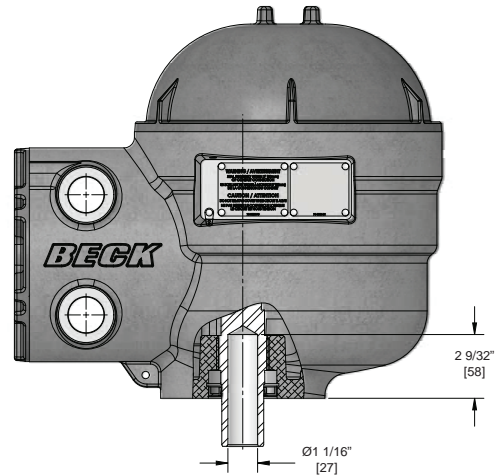
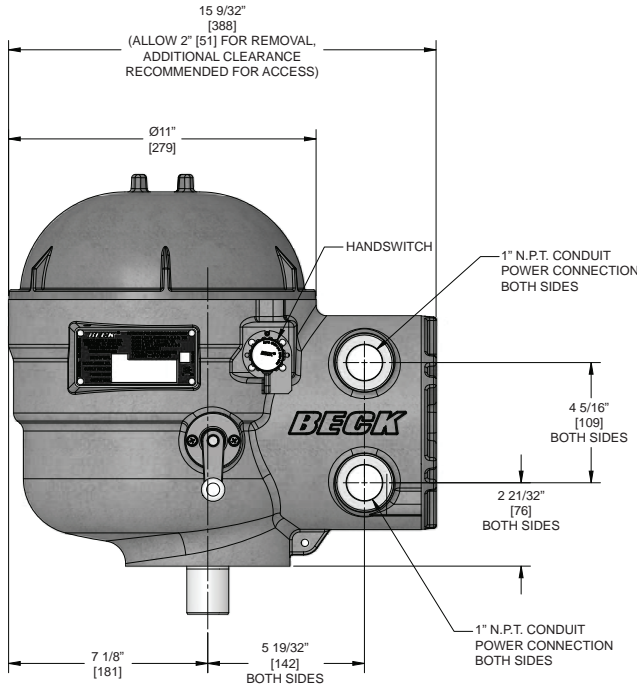

NOTE: Measurements shown in inches and [mm].

BECK MODEL 57-109

Approx. Weight	Rated Torque	Max. Overhung Load
59 lbs. 27 kgs.	120 lb-ft 163 N•m	750 lbs. 340 kgs.

DIRECT MOUNT FASTENER GUIDE

	Size (in.)	Torque* lb-ft [N•m]
Coupling Screws	5/8-18	170 [230]
Actuator Mounting Screws	3/8-16	25 [34]

*May vary per application.

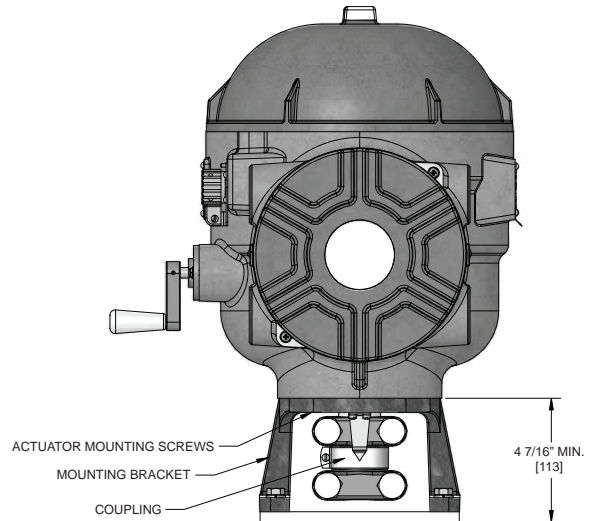

VALVE DIRECT MOUNT HARDWARE



GROUP 75



COMPACT ROTARY ACTUATOR

Mounting flexibility combined with a highly compact design make this actuator ideal for all types of small rotary valve and Windbox damper applications.

The Beck Group 75 actuator has an evolutionary design that combines the performance, reliability and control advantages of Beck actuators with an extremely efficient and flexible form factor. The design is smaller and lighter than the Group 11 and more robust than the Group 31. It also incorporates technologies that allow for an optional low temperature version rated for -50°C (-58°F) or a high temperature version rated for 120°C (248°F)—exceeding Beck's standard rating of 85°C (185°F) for the Group 11 and 65°C (150°F) for the Group 31. The high temperature capabilities and efficient, flexible packaging make the Group 75 ideal for space restricted, hot environments typical of boiler windbox applications. It is also well-suited for small rotary valve applications in tight spaces. This actuator shares electronics and

firmware with existing Beck products.

This interchangeability of electronics keeps critical spare parts common with existing Beck actuators. It also means that all the latest configuration, setup and diagnostic features are available as well.



FEATURES

Beck Motor

Precise, Reliable Control

Together with Beck's control electronics and rugged gear train, Beck motors provide the precise, reliable positioning required for modern control loops.

- Never overheats or burns out—even under demanding modulating control or stalled conditions.
- Reaches full speed and torque in less than 50 milliseconds and stops within 25 milliseconds; eliminating deadtime.
- Provides extremely accurate positioning in modulating applications.
- Will not coast or overshoot the desired position.
- Low current draw (0.16 A to 0.40 A) and low power consumption permit the use of uninterruptible power supplies; also eliminates the need for relays.
- Maintenance-free with double-lipped grease-sealed bearings.

Electric Handswitch

Time-Saving Local Operation

Dampers or valves may be operated at their individual locations with the built-in electric Handswitch. This saves time during installation and troubleshooting, allowing online adjustments to be made quickly and easily bypassing the electronics in the actuator and control system.

The Handswitch also serves as an electrical backup in the event of control system failure.

Auxiliary and Over-travel Limit Switches

Two over-travel protection limit switches are provided. Up to four auxiliary switches are available. Switch features:

- SPDT switches rated for a minimum of 6 A at 120 Vac, (three times maximum motor current for most models) to ensure long life.
- Field-adjustable to operate at any point in the actuator's travel range.
- May initiate secondary functions or provide remote indication of actuator position.
- Eliminates unreliable and maintenance-intensive proximity switches.

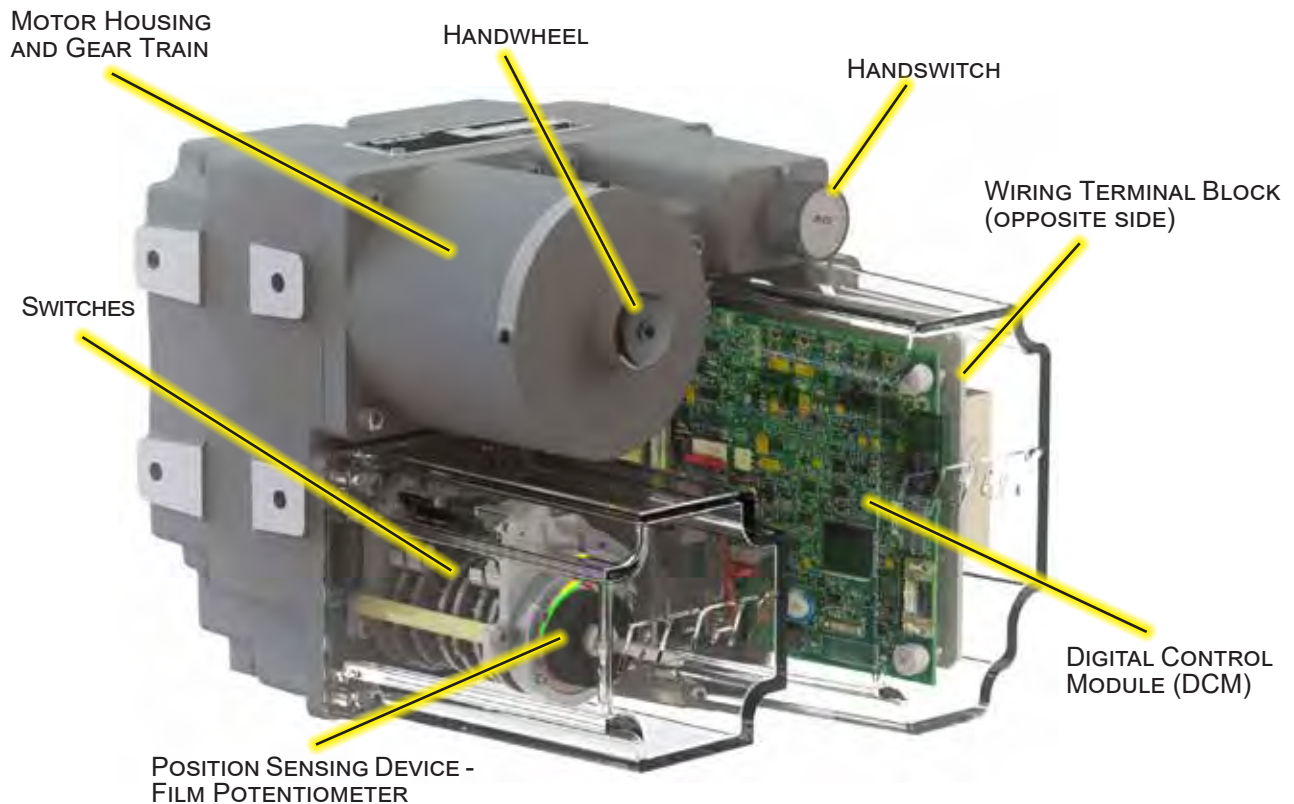

Gear Train

Power and Durability to Maximize Control Availability

Beck's durable gear train maintains accurate, consistent control element positioning even under the demanding conditions of an active control loop.

- Gear trains employ a unique, all spur gear construction of heat-treated alloy steels and ductile iron.
- Efficient, wide-face spur gearing essentially eliminates wear-induced backlash and positioning inaccuracies.
- Durable design provides up to 4 days of protection against intermittent or extended accidental stalls.
- Integral Self-Locking Mechanism (SLM) ensures that drives hold a minimum of 200% of rated torque with the motor de-energized.

Manual Handwheel

Convenient Manual Control Without Declutch

An easy-to-turn, spoke-free Handwheel is incorporated into the Group 75 design to allow manual operation during installation or power outages.

- Handwheel can be used to move valves and dampers to any position smoothly and easily under full load conditions.
- Mechanical stops in housing prevent manual overtravel.
- The motor operates at 72 or 120 RPM, so the Handwheel poses no safety hazard.

Housing

Superior Protection and Convenient Access to Components

Beck actuators feature a cast aluminum body with individual compartments to protect components from moisture and dirt, and allow easy access for installation and calibration.

- Precision-machined aluminum alloy castings with corrosion-resistant polyurethane paint provide a rugged, dust-tight, weatherproof enclosure designed to meet Type 4X standards. Models approved for use in Hazardous classified locations are available—contact a Beck Sales or Application Engineer for details.

- Individual compartments protect all major components: Motor, DCM, CPS, gear train and installation wiring terminal boards.
- Each compartment can be accessed without exposing other components.
- Gasketed, precision-machined covers provide extra protection for harsh indoor and outdoor environments.
- Output and Handwheel shafts are also sealed with weatherproof, double-lip seals.

Mounting Versatility

Beck Group 75 Actuators may be Mounted in any orientation for Greater Installation Flexibility

Beck actuators are configured and lubricated in such a way that they may be mounted in any convenient position. This flexibility allows actuators to be installed in hard-to-fit locations.

As long as housing compartments remain accessible, there are no mounting orientation limits.

Additional Features

High Temperature Version

Optional high temperature model rated up to 120°C (248°F).

Low Temperature Version

Optional low temperature model rated down to -50°C (-58°F).

Remote Mounted Electronics

The electronics compartment can be removed and remotely located to accommodate challenging heat, space, or access issues.



CONTROL OPTIONS & SAMPLE WIRING DIAGRAMS

Diagrams are functional—customer wiring may vary. Certified wiring diagrams can be provided for the drive you select.

Option 9, Modulating Digital Position Control with Potentiometer Position Sensing

The Beck DCM positions the drive in proportion to an input current or voltage signal, and the Film Potentiometer provides integral feedback for the DCM. A 4–20 mA position feedback signal is available for remote indication. Foundation Fieldbus is also available.

The DCM may be used to provide pre-determined positioning of the drive upon loss of input control signal.

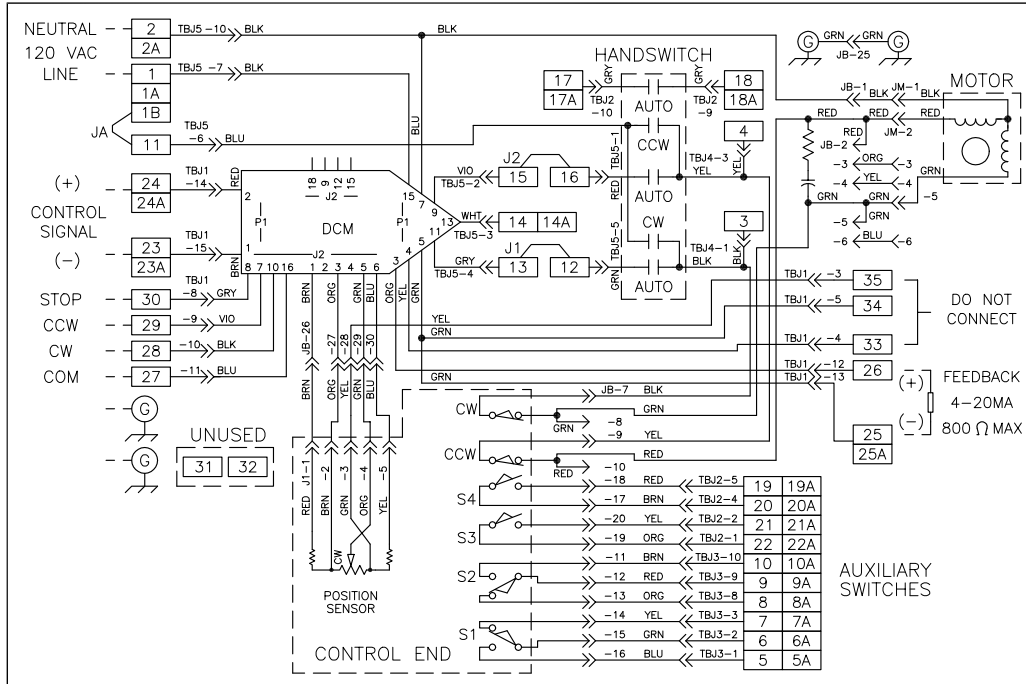

Option 6, Modulating Direct AC Control with Contactless Position Sensor (CPS)

Customer must supply three wires to directly control the drive motor direction: One 120 Vac line to run CW (terminal 12), one 120 Vac line to run CCW (terminal 16), and one neutral (terminal 2). Customer must supply two additional wires to power the “2-wire” type CPS (see your specific wiring diagram or the typical wiring diagram below).

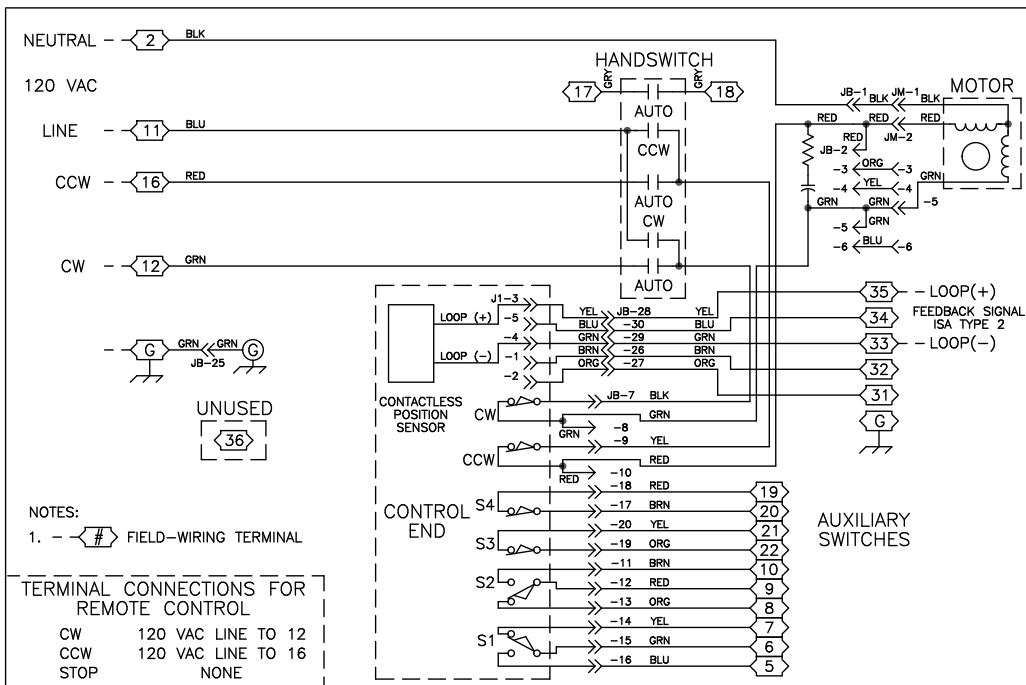

Option 5, Modulating Direct AC Control with Potentiometer Position Sensing

Customer must supply three wires to directly control the drive motor direction: One 120 Vac line to run CW (terminal 12), one 120 Vac line to run CCW (terminal 16), and one neutral (terminal 2). The position feedback potentiometer connections are available at terminals 32 (CW), 33 (wiper), and 34 (CCW).

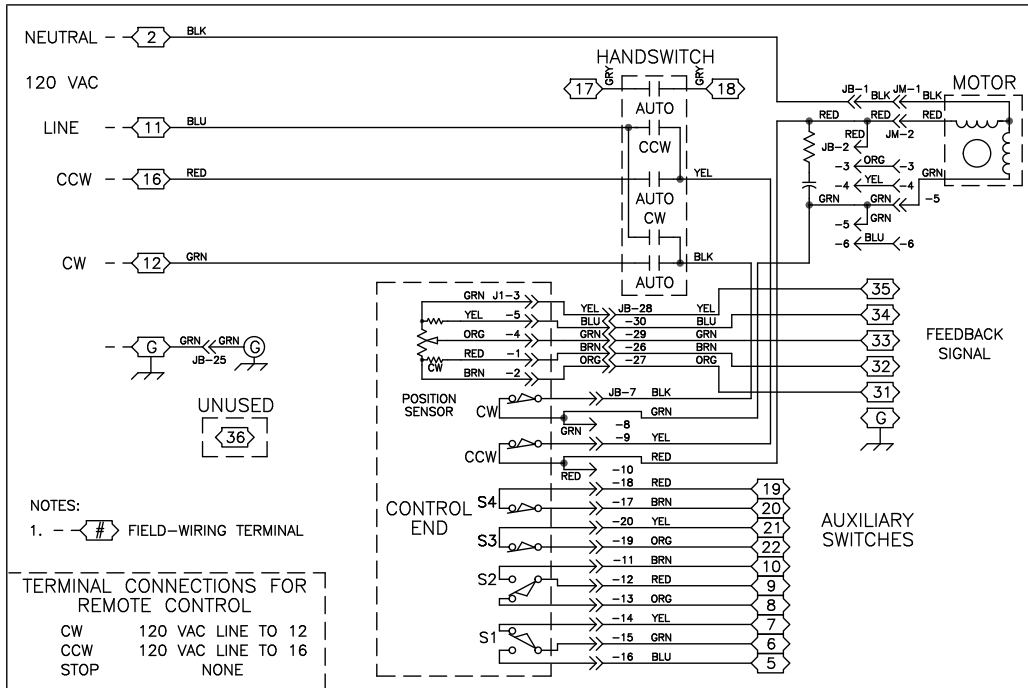

Option 3, Open / Close Direct AC Control

Customer must supply three wires to directly control the drive motor direction: One 120 Vac line to run CW (terminal 12), one 120 Vac line to run CCW (terminal 16), and one neutral (terminal 2).

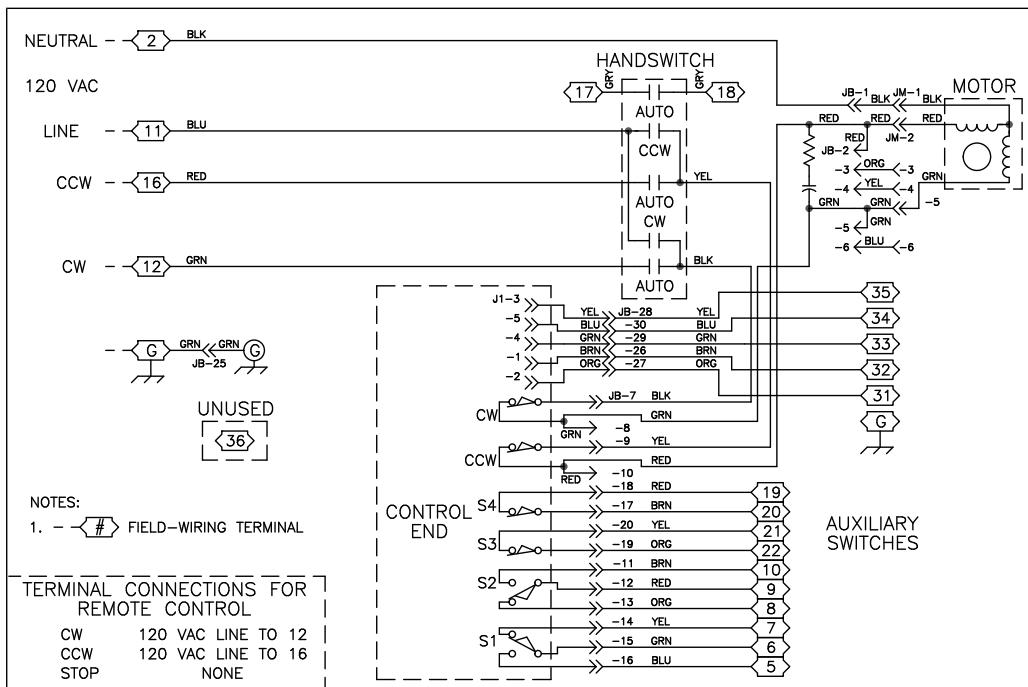

SPECIFICATIONS

Input Power 120 Vac, single-phase 50 or 60 Hz
Output Torque & Timing 40 lb-ft. (54 N•m), 40 sec./100° or 36 sec./90° 80 lb-ft. (108 N•m), 40 sec./100° or 36 sec./90° 80 lb-ft. (108 N•m), 24 sec./100° or 22 sec./90° <i>Note: Above timings are at 60 Hz; 50 Hz timing data does not exceed 120% of 60 Hz levels.</i>
Operating Conditions –20° to 85°C (–4° to 185°F) - Standard. –20° to 120°C (–4° to 248°F) - Optional (High Temperature). –50° to 85°C (–58° to 185°F) - Optional (Low Temperature).
Isolation Demand Input and Position Feedback signals are isolated from the ground and the ac power line.
Action on Loss of Power Stays in place.
Control Types Modulating with Digital Control Module (DCM) Modulating direct ac motor control with CPS or Film Potentiometer 2 position (open/close) control
Input and Feedback Signals 4–20 mA (1–5 Vdc input is possible with Option 9 actuators)
Available Communication Protocols Option 9 actuators may be equipped with HART® or Foundation Fieldbus. Contact a Beck Sales Engineer for details and information regarding other options.
Minimum Step Size (Modulating Control) DCM -- 0.10% (0.15% typical) (configurable) Direct AC -- 0.1° (function of control system capabilities)
Stall Protection (protects actuator and driven elements under stall conditions) DCM -- Time to stall is configurable from 30 to 300 seconds.
Action on Loss of Input Signal (Power On) Stays in place or, with DCM, is field configurable to move to any preset position.
Overtravel Limit Switches (Dedicated) Two Form C switches provide overtravel protection (Option 9) or end-of-travel limits (Option 6, 5, 3).
Auxiliary Switches (Non-Dedicated) Up to four 3A, 120 Vac switches available. Switches are cam-operated and field-adjustable.
Handswitch Permits local electrical operation independent of the controller signal. Standard on all units. An optional auxiliary contact can be used to indicate that the Handswitch is in "AUTO" mode or to sound an alarm if it is taken out of "AUTO".
Handwheel Provides manual operation without electrical power.
Mechanical Stops Prevent overtravel during automatic or manual operation.
Enclosure Precision-machined, aluminum alloy castings painted with corrosion-resistant polyurethane paint provide a rugged, dust-tight, weatherproof enclosure. Designed to meet Type 4X and IP68 (3 meters/48 hours). <i>NOTE: Internal water damage is not covered by warranty.</i>
Mounting Orientation Any orientation—no limitations.
Standards CSA labeled (US & Canada).

OUTLINE DIMENSION DRAWINGS

Model 75-109

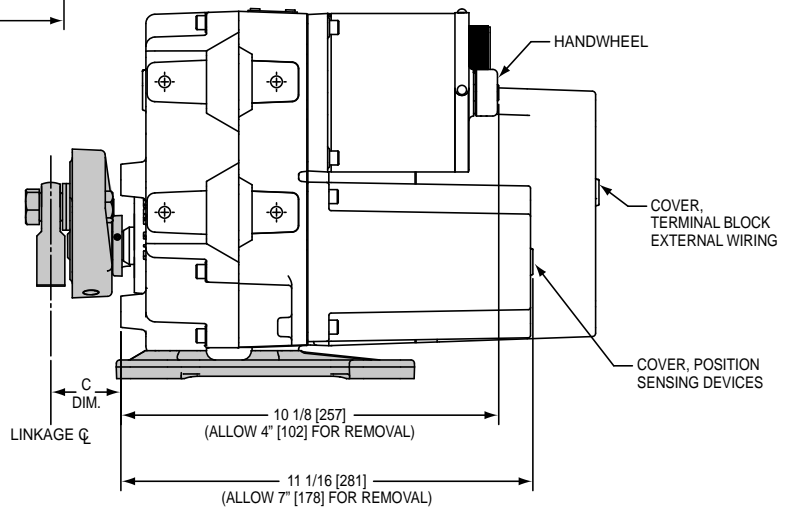
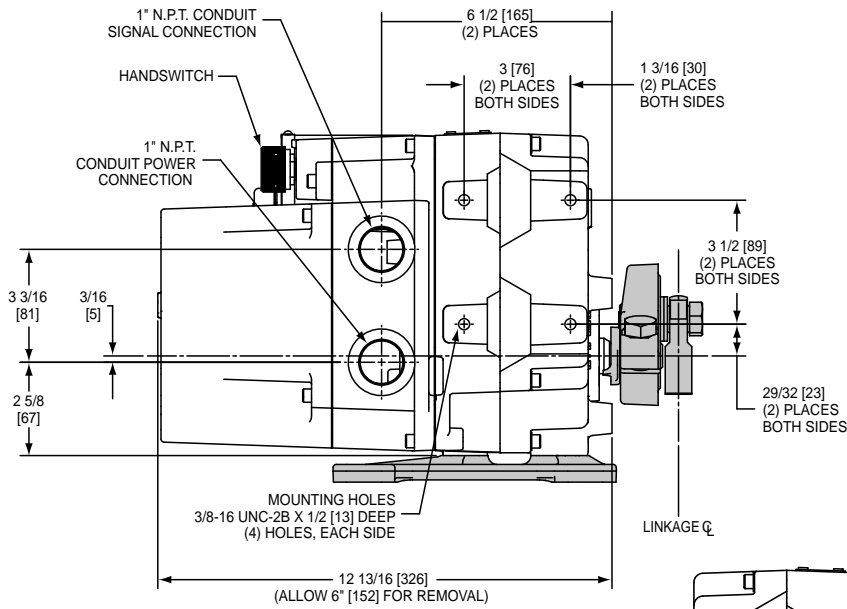
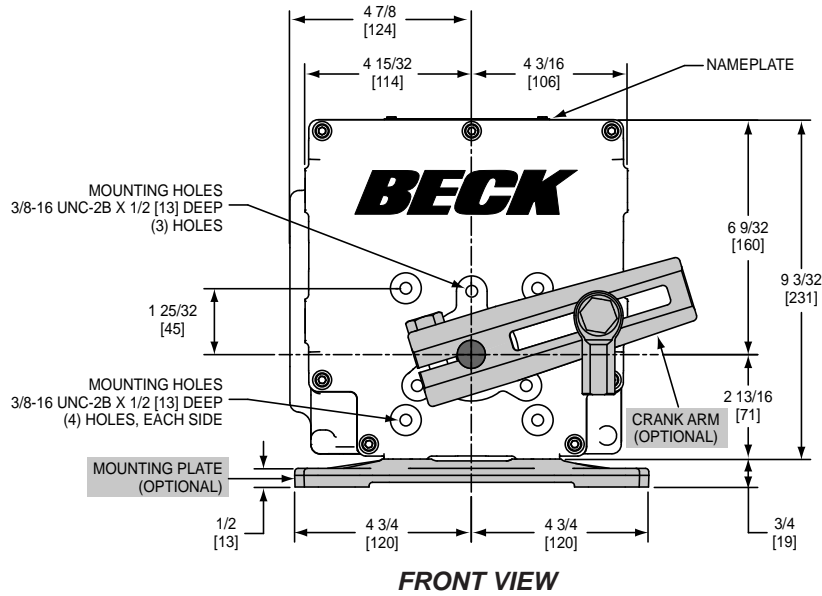

Actuators may be mounted in any orientation.

All dimensions are subject to change. Request certified dimensional drawings for the actuators you select.

OUTLINE DIMENSION DRAWINGS

Model 75-106/-105/-103

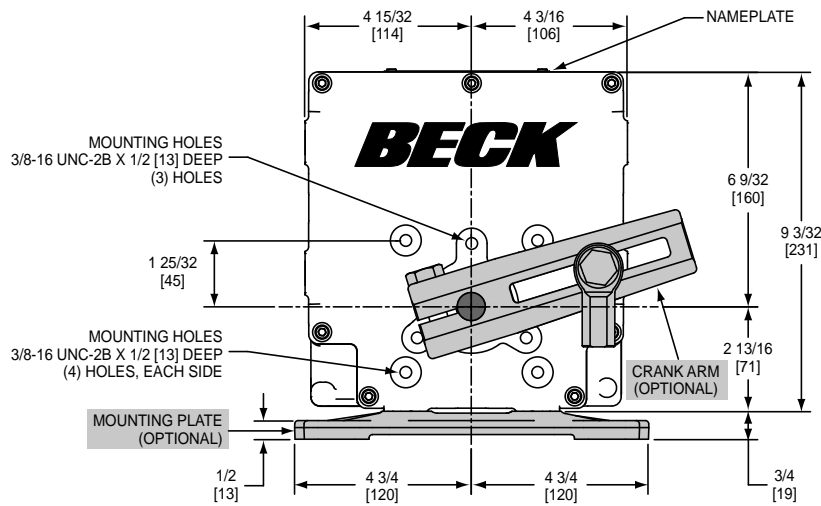

FRONT VIEW

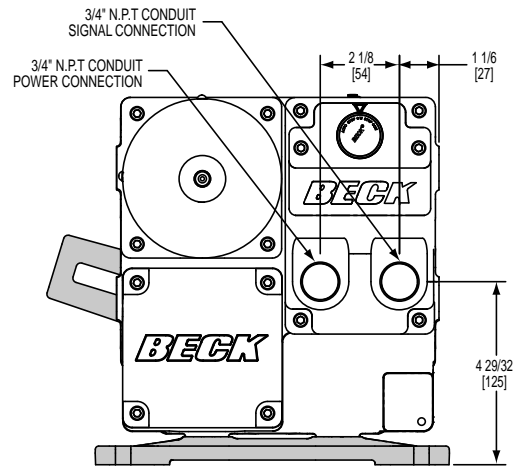

REAR VIEW

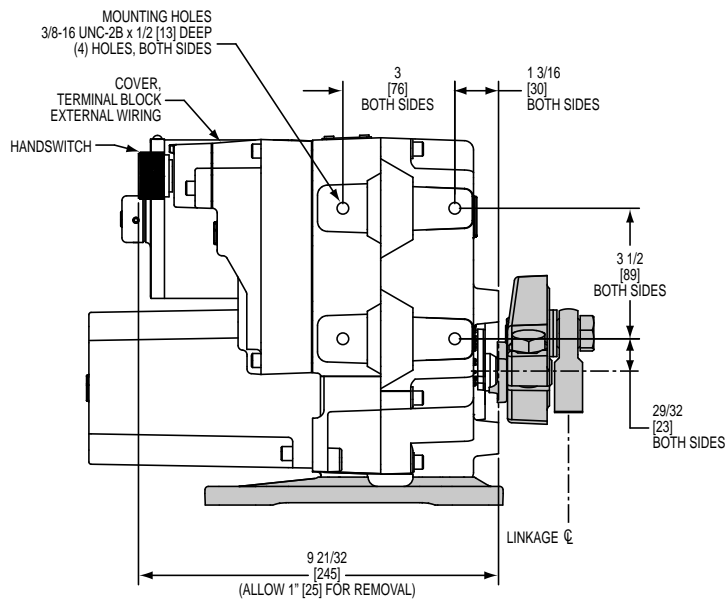

SIDE VIEWS

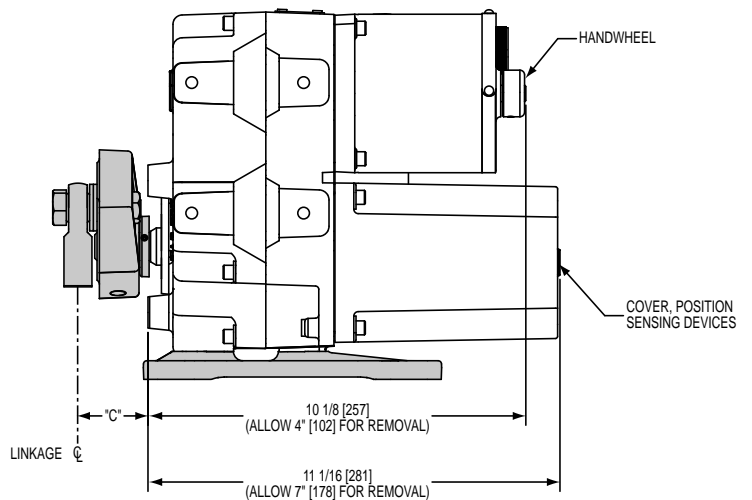

BOTTOM MOUNTING LOCATIONS

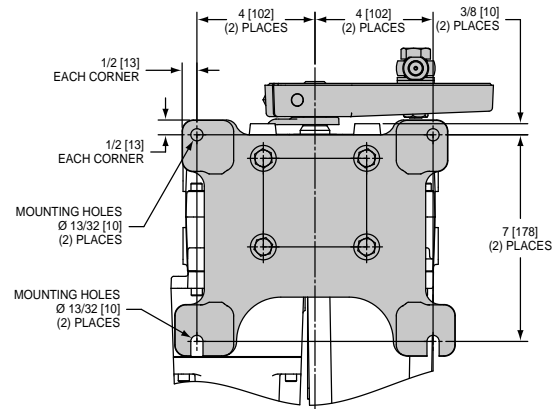
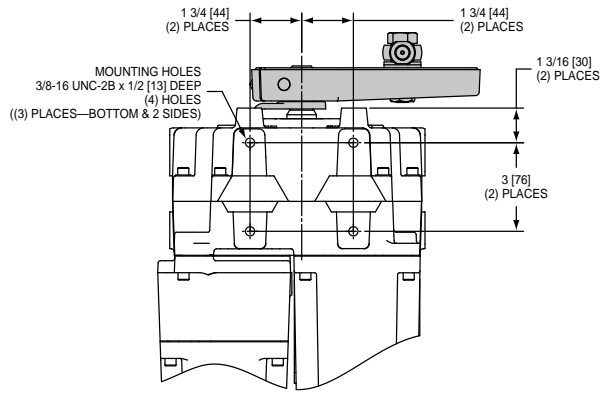

WITH OPTIONAL MOUNTING PLATE

OPTIONAL CRANK ARM DETAIL (Crank Arm 10-3491-05 shown)

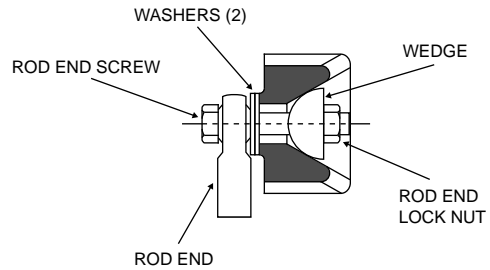
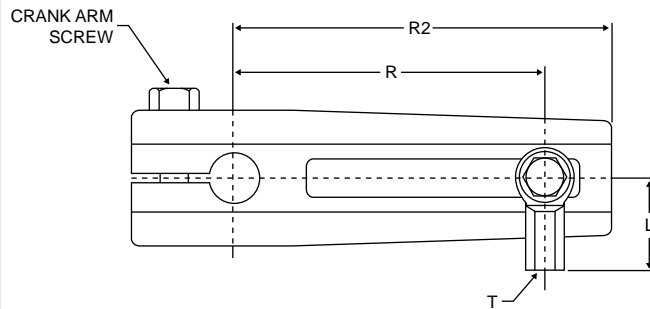

Drives may be mounted in any orientation.

All dimensions are subject to change. Request certified dimensional drawings for the drives you select.

MODEL INFORMATION

Max. Torque (lb-ft)[N•m]	Optional Crank Arms and Rod Ends						Output Shaft Dia. (in)[mm]	Approx. Weight (lbs)[kgs]	Maximum Overhung Load (lbs)[kgs]
	Crank Arm Part No.	Crank Arm Radius (adj.) "R" (in)[mm]	Crank Arm Radius "R2" (in)[mm]	Linkage Center to Front Mtg. Bosses "C" (in)[mm]	Rod End Length "L" (in)[mm]	Rod End Internal Thread "T" (in)[mm]			
80 [108]	10-3491-05	1 1/2-5 1/8 [38-130]	6 3/32 [155]	1 27/32-1 7/8 [47-48]	2 1/8 [54]	1/2-20 x 1 3/16 [30]	3/4 [19]	46 [21]	750 [340]
80 [108]	10-3491-52	1 1/2-4 [38-102]	4 11/16 [119]	1 21/32-1 15/16 [42-49]	2 1/8 [54]	1/2-20 x 1 3/16 [30]	3/4 [19]	46 [21]	750 [340]
40 [54]	10-3492-02	1 1/2-5 1/8 [38-130]	5 11/16 [144]	1 11/32-1 3/4 [34-44]	1 3/8 [35]	5/16-24 x 3/4 [19]	3/4 [19]	46 [21]	500 [227]

RECOMMENDED SCREW TORQUES

	Screw Size (in)	Torque (lb-ft)[N•m]	Crank Arm Part No.	Crank Arm Screw Size (in)	Torque (lb-ft)[N•m]	Rod End Screw Size (in)	Torque (lb-ft)[N•m]	Rod End Lock Nut Size (in)	Torque (lb-ft)[N•m]
Cover Screw	1/4-20	6 [8]	10-3491-05	1/2-13	75 [102]	1/2-13	35 [47]	1/2-13	55 [75]
Motor Screw	1/4-20	6 [8]	10-3491-52	3/8-24	50 [68]	1/2-13	35 [47]	1/2-13	55 [75]
Mounting Plate Screw (optional)	3/8-16	20 [27]	10-3492-02	5/16-24	20 [27]	5/16-24	20 [27]	5/16-24	20 [27]



GROUP 14

LINEAR VALVE ACTUATOR

Providing up to 4,000 lbs. of thrust, this actuator incorporates a unique design feature that ensures tight shut-off at the end of travel—commonly used on globe valve applications

Group 14 actuators are ideal for steam flow control, combustion control and any other application which requires more precise valve position control or faster response than pneumatic or electric actuators can deliver.

Valves and actuators may be ordered together as factory-mounted assemblies, ready for drop-in installation, or actuators can be supplied separately along with the necessary hardware for field installation on existing valves.

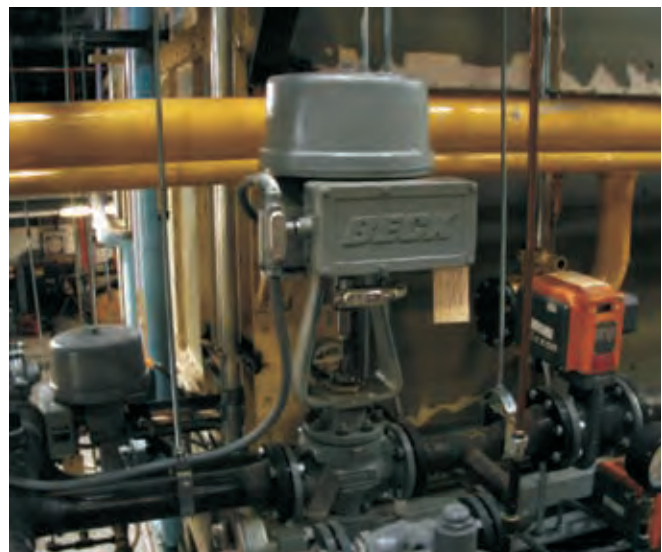

FEATURES

Beck Actuator Motor

Precise, Reliable Control

Together with Beck's control electronics and rugged gear train, Beck motors provide the precise, reliable positioning required for modern control loops.

- Never overheats or burns out, even under demanding modulating control or stalled conditions.
- Reaches full speed and torque in less than 50 milliseconds and stops within 25 milliseconds, eliminating deadtime.
- Provides extremely accurate positioning in modulating applications.
- Will not coast or overshoot the desired position.
- Low current draw of 0.33 A to 1.5 A, and therefore low power consumption, eliminates the need for relays and permits the use of uninterruptible power supplies.

Electric Handswitch

Time-Saving Local Operation

Valves may be operated at their individual locations with the built-in electric Handswitch. This saves time during installation and troubleshooting, allowing online adjustments to be made quickly and easily by bypassing the electronics in the actuator and control system.

The Handswitch also serves as an electrical backup in the event of control system failure.

Auxiliary and Over-travel Limit Switches

Two dedicated over-travel protection limit switches (RET, EXT) and two form C auxiliary switches (S1, S2) are provided. Two additional auxiliary switches (S3, S4) are optionally available.

- SPDT switches rated for a minimum of 6 A at 120 Vac, (three times maximum motor current for most models) to ensure long life.
- Field-adjustable to operate at any point in the actuator's travel range.
- May initiate secondary functions or provide remote indication of actuator position.
- Eliminates unreliable and maintenance-intensive proximity switches.

Drive Train

Power and Durability to

Maximize Control Availability

Beck's durable gear train maintains accurate, consistent control element positioning even under the demanding conditions of an active control loop.

- Gear trains use an all spur gear construction of heat-treated alloy steels and ductile iron.
- Efficient, wide-face spur gearing essentially eliminates wear-induced backlash and positioning inaccuracies.

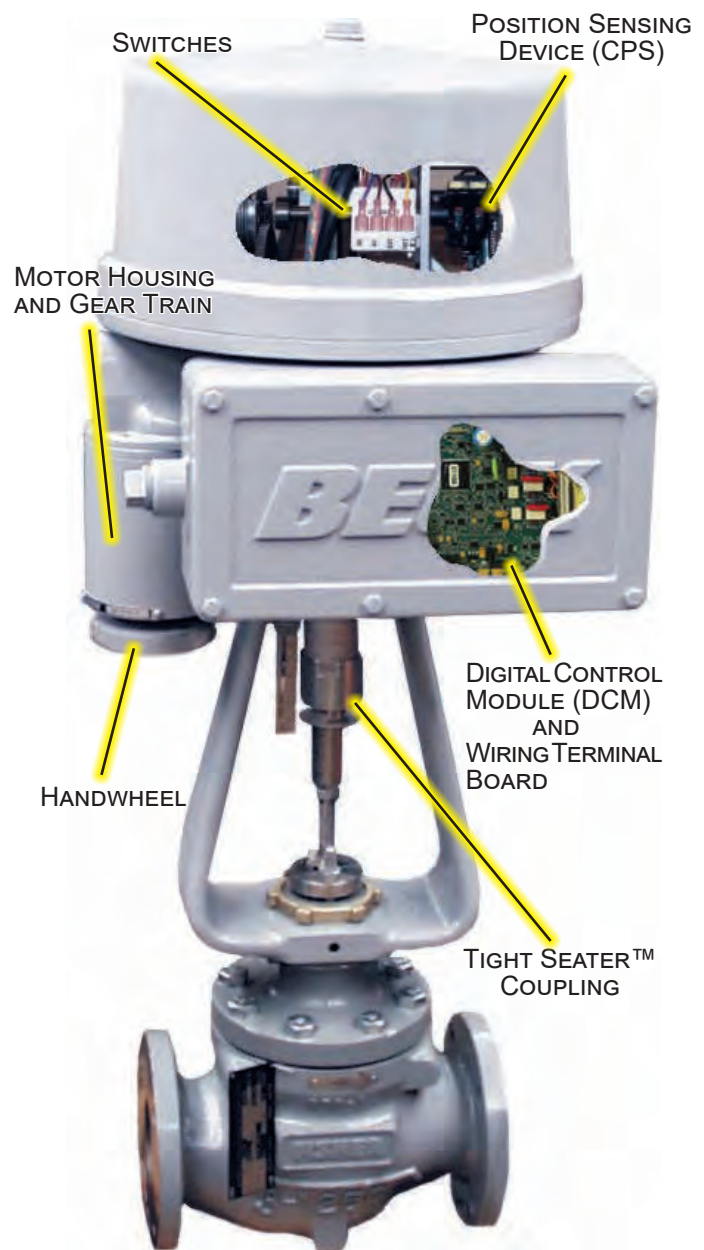

Model 14 Components

- Integral self-locking mechanism ensures that drives hold a minimum of 200% of rated torque with the motor de-energized.

Manual Handwheel

Convenient Manual Control Without Declutch

An easy-to-turn, spoke-free Handwheel allows manual operation during installation or power outages.

- Moves valves to any position smoothly and easily, even under full load conditions.
- Mechanical stops in housing prevent manual overtravel.
- The motor operates at 60 or 72 RPM, so the Handwheel poses no safety hazard.

Housing

Superior Protection and Convenient Access to Components

Beck actuators feature a cast aluminum body with individual compartments to protect components from moisture and dirt, and allow easy access for installation and calibration.

- Precision-machined aluminum alloy castings with corrosion-resistant poly-urethane paint provide a rugged, dust-tight, weatherproof enclosure.
- Individual compartments protect all major components.
- Each compartment can be accessed without exposing other components.
- Gasketed, precision-machined covers provide extra protection for harsh indoor and outdoor environments.
- Output and Handwheel shafts are also sealed with weatherproof, double-lip seals.

Mounting Versatility

Beck Actuators can be Mounted in any Orientation for Greater Installation Flexibility

Beck actuators are configured and lubricated in such a way that they may be mounted in any convenient position. This flexibility allows actuators to be installed in hard-to-fit locations.

Tight-Seater™

The unique Tight-Seater™ coupling incorporated into every unit provides positive seating of the valve plug for tight shutoff. This device compresses the plug into the seat of the valve until the actuator reaches its end of travel, for a seating force at least equal to the rated thrust of the valve. A patented self-locking mechanism holds the output shaft in position even when the motor is de-energized.

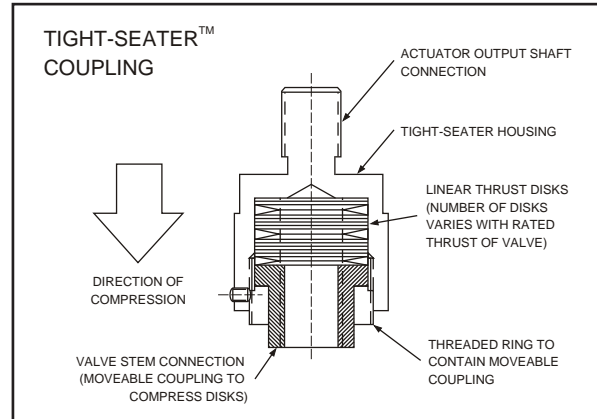

One-Step Valve Travel Adjustment

Beck's unique Calibar index allows fast and easy travel adjustment because position feedback devices and over-travel limit switches are all adjusted at the same time. Intermediate auxiliary switches are automatically adjusted to the same percentage of full travel.

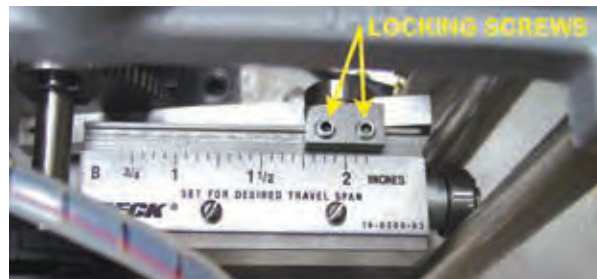

Factory Mounted Assemblies

Beck will supply Group 14 actuators mounted to valves, fully tested and ready for simple drop in installation.

Group 14 actuators are generally furnished with a standard cast yoke for globe valves with boss sizes up to 3 3/4" [95 mm]. When the Group 14 actuator is installed on valves with boss sizes exceeding 3 3/4" [95 mm], special yokes are built to provide sturdy, deformation-free assemblies.

CONTROL OPTIONS & SAMPLE WIRING DIAGRAMS

Diagrams are functional—customer wiring may vary. Certified wiring diagrams can be provided for the actuator you select.

Modulating Option 9

Digital Position Control with Contactless Position Sensing

The Beck DCM positions the actuator in proportion to an input current or voltage signal, and the CPS provides integral feedback for the DCM. A 4–20 mA position feedback signal is available for remote indication. Foundation Fieldbus is also available.

The DCM may be used to provide pre-determined positioning of the actuator upon loss of input control signal.

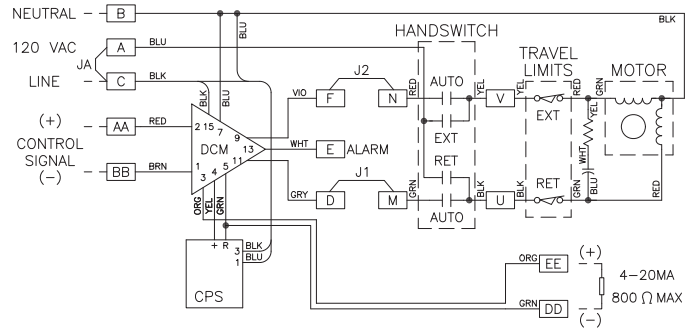

Modulating Option 8

Analog Position Control with Contactless Position Sensing

The Beck ESR positions the actuator in proportion to an input current or voltage signal, and the CPS provides integral feedback for the ESR and isolated feedback for remote position indication (also available without external feedback).

The ESR may be used to provide pre-determined positioning of the actuator upon loss of input control signal.

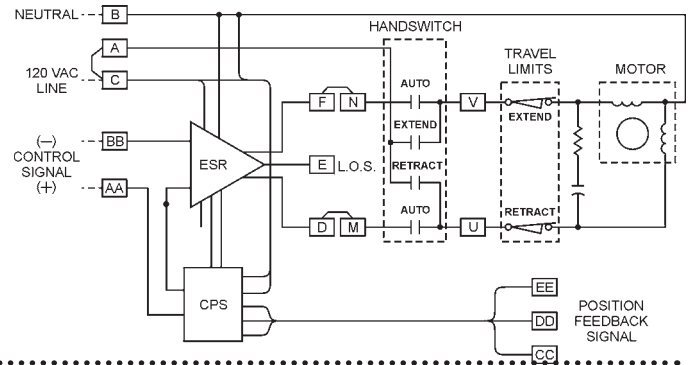

Modulating Option 7

Analog Position Control with Potentiometer Position Sensing

The Beck ESR positions the actuator in proportion to an input current or voltage signal. A film potentiometer is used in place of the CPS for position sensing and internal feedback to the ESR.

An optional auxiliary potentiometer, requiring external power, may be added for remote position indication or control. The ESR may be used to provide predetermined positioning of the actuator upon loss of input control signal.

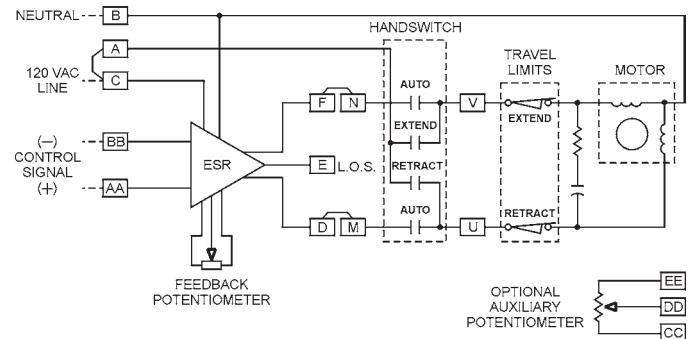

Modulating Option 6

Direct AC Control with Contactless Position Sensing

Control option 6 features clockwise / counterclockwise control from a remote automatic controller or manual switches.

The CPS provides a feedback signal for remote position indication.

If the available 120 / 240 Vac control voltage is not able to supply enough current to operate an actuator, a Relay Board must be added to the control compartment.

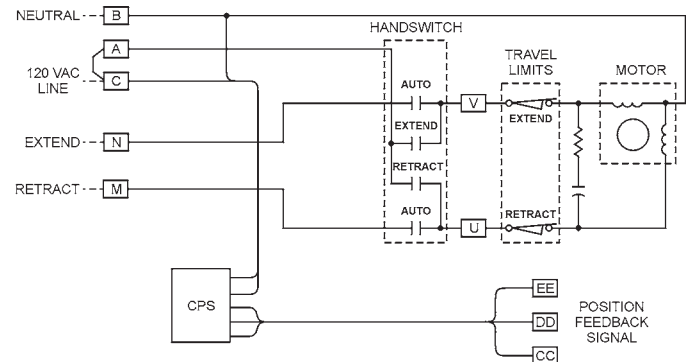

Modulating Option 5

Direct AC Control with Potentiometer Position Sensing

Actuated in clockwise or counterclockwise from a remote location or manual switches, this configuration includes a 1000 ohm film potentiometer for remote feedback. An optional auxiliary 1000 ohm potentiometer can be added as an additional remote position indication.

If the available 120 / 240 Vac control voltage is not able to supply enough current to operate an actuator, a Relay Board must be added to the control compartment.

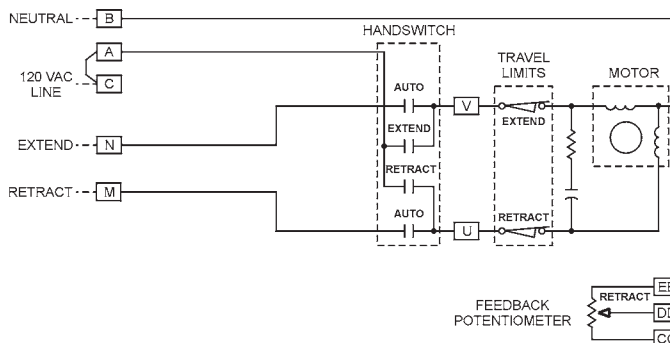

Multi-Position Option 4

Direct AC Control with Cam-Operated Switches to Stop Drive Travel

Option 4 incorporates adjustable cam-operated switches to stop the actuator in 6 positions (two end-of-travel, four intermediate positions), or 3 positions (one intermediate position). 4-position and 5-position control can also be attained using a different number of switches.

Standard end-of-travel switches have extra contacts that can be used for external signaling or interlocking.

Configuration shown: BASIC 3-position.

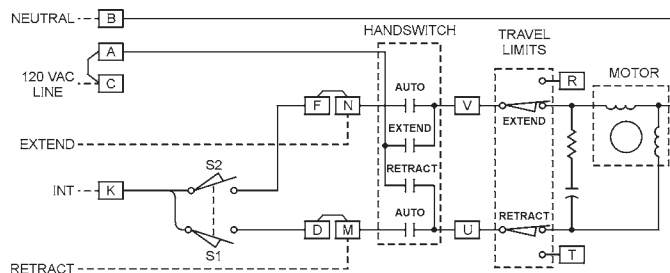

Open / Close Option 3

Direct AC Control

For simple open / close operation, Option 3 includes two limit switches, which stop the actuator at each end of travel and may also be used for external signaling.

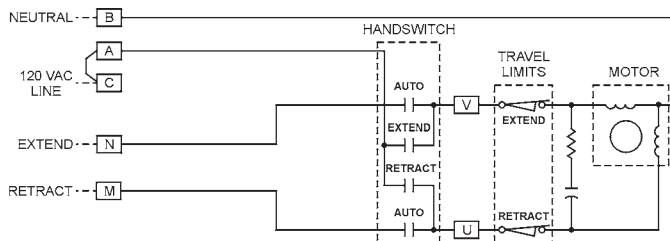

Other operating voltages available

All of the options described on this page and the previous page are available for 240 Vac operation instead of 120 Vac operation.

Auxiliary Switch Terminals

Auxiliary switches may be added for control or annunciation functions. Switches are rated at 6 A 120 Vac. They may be factory-set or field-adjusted to operate at any point in the drive's travel.

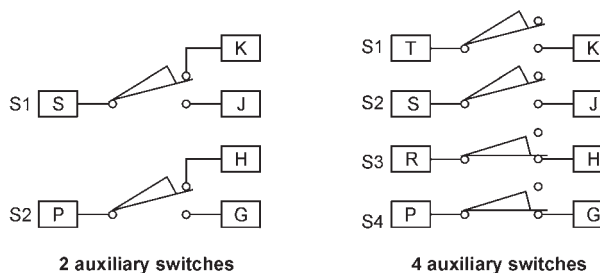

2 auxiliary switches

4 auxiliary switches

SPECIFICATIONS

Input Power 120 Vac, single-phase 50 or 60 Hz 240 Vac, single-phase 50 or 60 Hz
Operating Conditions -40° to 185°F (-40° to 85°C)
Isolation Demand Input and Position Feedback signals are isolated from the ground and ac power line.
Action on Loss of Power Stays in place.
Control Types Modulating (DCM) digital control Modulating (ESR) analog control Modulating direct ac control 3,5 or 6 position control 2 position (open/close) control
Input and Feedback Signals Depends upon the control option (see below)
Available Communication Protocols (control option 9) HART® (standard). Options: Foundation Fieldbus, Profibus PA and Modbus RTU.
Minimum Step (Modulating Control) DCM -- 0.10%, 0.15% typical (configurable) ESR -- 0.10%, 0.15% typical Direct AC -- 0.1° (function of control system capabilities)
Stall Protection (protects actuator and driven elements under stall conditions) Control option 9 -- Time to stall configurable from 30 to 300 seconds. Other control types -- Optional Stall Protection Module is available.

Action on Loss of Input Signal (Power On) Stays in place or, with some options, is field configurable to move to any preset position.
Over-travel Limit Switches (Dedicated) Two Form C switches (one for each direction of travel).
Auxiliary Switches (Non-dedicated) Up to four 6A, 120 Vac switches available. Switches are cam-operated, field-adjustable.
Handswitch Permits local electrical operation independent of the controller signal. Standard on all units. An optional auxiliary contact can be used to indicate that the Handswitch is in "AUTO" mode or to sound an alarm if it is taken out of "AUTO". A locking Handswitch is also available.
Enclosure Precision machined aluminum alloy castings, painted with corrosion resistant polyurethane paint. Rated Type 4, IP66.
Standards CSA Labeled (US & Canada); CE Compliant <i>NOTE: For standards not specifically listed, please call Beck for more information at 215-968-4600.</i>
Mounting Orientation Any orientation—no limitations.

Use the charts on this page to create a full specification model number.

First, select the basic model no. from the chart at right (blue column) and enter the first four digits in the blue "Model No." field below. Now select the control option that suits the application requirements using the information in the chart at the bottom of the page (brown area). Enter the control option designation number (3 through 9) in the brown area of the "Model No." field below.

The next step is to determine the required thrust for the application as well as select the full stroke time in seconds as shown in the chart at right (green and yellow columns). Enter the selected thrust option in the green "Thrust" field and the selected timing option in the yellow "Timing" field below.

Finally, select the number of auxiliary switches desired (0, 2 or 4) and enter that number in the purple "Aux. Switches" field below.

The full specification model number is complete and can be used to specify a Beck drive.

For example, **14-109-1000-27-2** denotes a 14-100 basic model for modulating control (option 9 Digital Control Module) that is rated for 1,000 lbs thrust (4450 N) output with a full stroke time of 27 sec/in (1.06 sec/mm). It is equipped with two auxiliary form C switches.

CONTROL OPTION CHART

Basic Model No.	Thrust (lbs)[N]	Timing ⁴ (sec./in[cm])	Motor ^{1,2,3} Current (A)
14-100	340 [1513]	4 [1.6]	0.72
	425 [1891]	11 [4.3]	0.44
	600 [2670]	16 [6.3]	0.44
	650 [2893]	8 [3.1]	0.72
	800 [3560]	11 [4.3]	0.72
	1,000 [4450]	27 [10.6]	0.44
	1,100 [4895]	16 [6.3]	0.72
	1,620 [7209]	48 [18.9]	0.44
14-200	1,800 [8010]	27 [10.6]	0.72
	2,700 [12015]	16 [6.3]	1.20
	4,000 [17800]	24 [9.4]	1.20

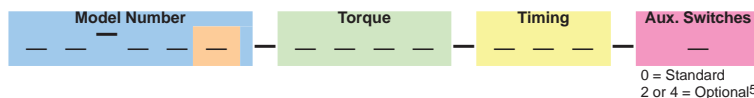

CONTROL OPTION CHART⁶

Control Option	Control Mode	Control Board	Std. Control Input	Position Sensor	Std. Position Feedback
9	Modulating	DCM*	4-20 mA	CPS	4-20 mA
8	Modulating	ESR	4-20 mA	CPS	4-20 mA
7	Modulating	ESR	4-20 mA	Film Pot.	None
6	Modulating	None	120 Vac	CPS	4-20 mA
5	Modulating	None	120 Vac	Film Pot.	Film Pot.
4	5-Position	None	120 Vac	None	None
4	3-Position	None	120 Vac	None	None
3	2-Pos. (Open/Close)	None	120 Vac	None	None

- 1 Unique Beck motor design has starting & stall current that approximate running current, so thermal overload protection is not required—just provide normal short-circuit protection.
- 2 Motor currents shown are 60 Hz -- 50 Hz currents do not exceed 120% of 60 Hz levels.
- 3 Actuator current @ 240 Vac is ~1/2 the 120 Vac current (motor current does not change @ 240 Vac).
- 4 Stroke timings shown are based on 60 Hz power; 50 Hz power provides timings 20% greater.
- 5 2 or 4 auxiliary switches are available for most Group 14 actuators. Contact the factory regarding switch availability on control option 4 models. Standard travel limit switches have extra contacts which can be used for external signaling on 2-, 3- or 5-position control modes.
- 6 Contact the factory if the signal options listed do not meet your requirements.

* Smart Digital Control Module with std. HART communication capabilities (Foundation Fieldbus is available as an extra cost option).

OUTLINE DIMENSION DRAWINGS

Model 14-100

(5/16" to 2 1/8" travel shown)

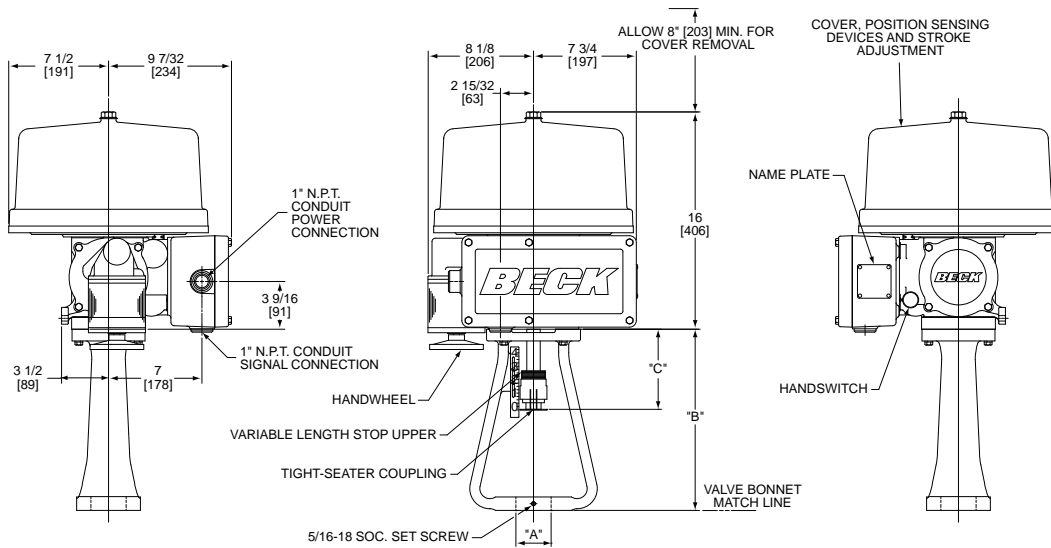

Model 14-200

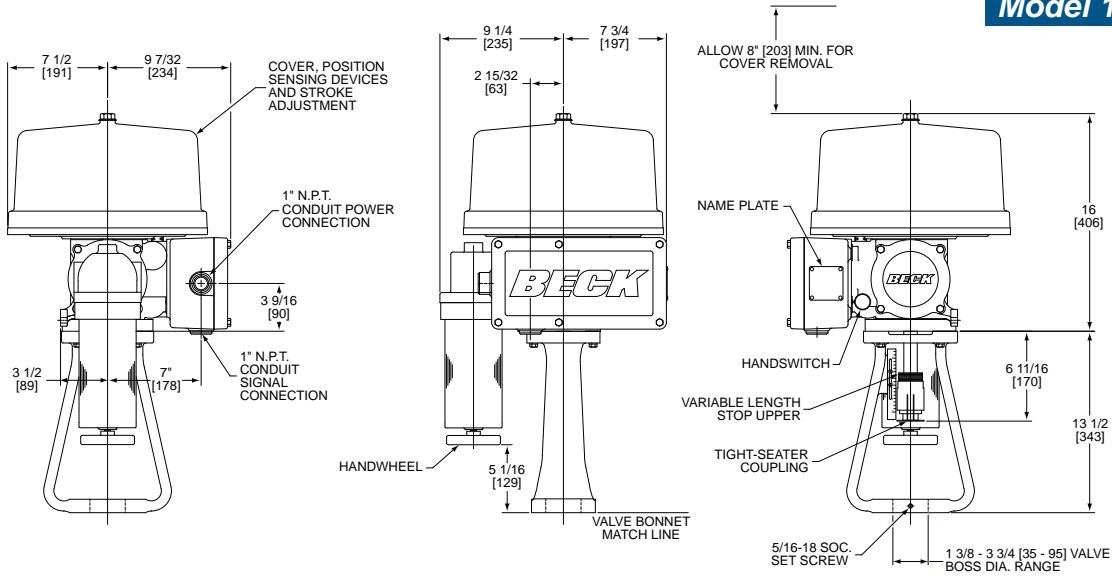

Mechanical Specifications

Beck Model No.	Actuator Shaft Travel Range in [mm]	"A" Valve Boss Dia. Range in [mm]	"B" Yoke Height in [mm]	"C" Nominal Drive Shaft Extension in [mm]	Max. Valve Stem Extension (Valve Stem Retracted) in [mm]	Approx. Weight lb [kg]
14-100	5/16-1 3/4 [8-44]	1-2 5/8 [25-67]	8 [203]	4 3/16 [106]	5 1/2 [140]	80 [36]
	3/4-2 1/8 [19-54]	1 3/8-3 3/4 [35-95]	13 1/2 [343]	6 [152]	9 1/4 [235]	92 [42]
14-100 w/ valve extension	3/4-3 1/2 [19-89]	1 3/8-3 3/4 [35-95]	19 13/16 [503]	12 5/16 [313]	9 1/4 [235]	100 [45]
	1 3/4-4 1/2 [44-114]					
14-200	5/16-1 3/4 [8-44]	1 3/8-3 3/4 [35-95]	13 1/2 [343]	6 11/16 [170]	9 [229]	105 [48]
	3/4-2 1/8 [19-54]					
14-200 w/ valve extension	3/4-3 1/2 [19-89]	1 3/8-3 3/4 [35-95]	19 13/16 [503]	13 [330]	9 1/4 [235]	113 [51]
	1 3/4-4 1/2 [44-114]					

Actuator may be mounted in any orientation.

All dimensions are subject to change. Request certified dimensional drawings for the actuators you select.



GROUP 29

LINEAR VALVE ACTUATOR

Providing up to 6,100 lbs. of thrust, this actuator incorporates a unique design feature that ensures tight shut-off at the end of travel—even in hazardous locations

Ideally suited for process control applications in even the harshest environments, the Group 29 handles valve thrust requirements up to 6,100 lbs. (27 134 N) and is easily mounted on most valves. A ball screw design combined with a new control algorithm and the traditional Beck motor design ensure repeatable modulation as precise as 0.1% of span. The Group 29 is designed for simple installation on almost any globe valve. The design incorporates a rugged, weatherproof body rated for hazardous locations to ensure safe operation in almost any plant environment.

Valves and actuators may be ordered together as factory-mounted assemblies, ready for drop-in installation, or actuators can be supplied separately along with the necessary hardware for field installation on existing valves.



FEATURES

Beck Actuator Motor

The Group 29 utilizes a low current draw, continuous duty motor design. The drive's onboard control electronics (DCM) directly feed the motor windings, thus eliminating external motor starters and controls completely. In addition, the motor will not coast or overshoot and will not overheat—even under continuous modulation.

Electric Handswitch

Similar to all Beck actuators, the Group 29 is equipped with an electrical override Handswitch to aid in setup and installation of the actuator independent of external control signals.

Auxiliary Switches

Two non-dedicated Form C and Form A switches are standard. These switches are cam-operated and easily adjusted in the field. Wiring connections are provided in the actuator terminal compartment to allow easy access.

Gear Train

The Group 29 utilizes a high efficiency gear train designed for high performance, long life and minimum wear. It consists of a combination of precision-cut alloy steel and ductile iron spur gears and a precision ball screw.

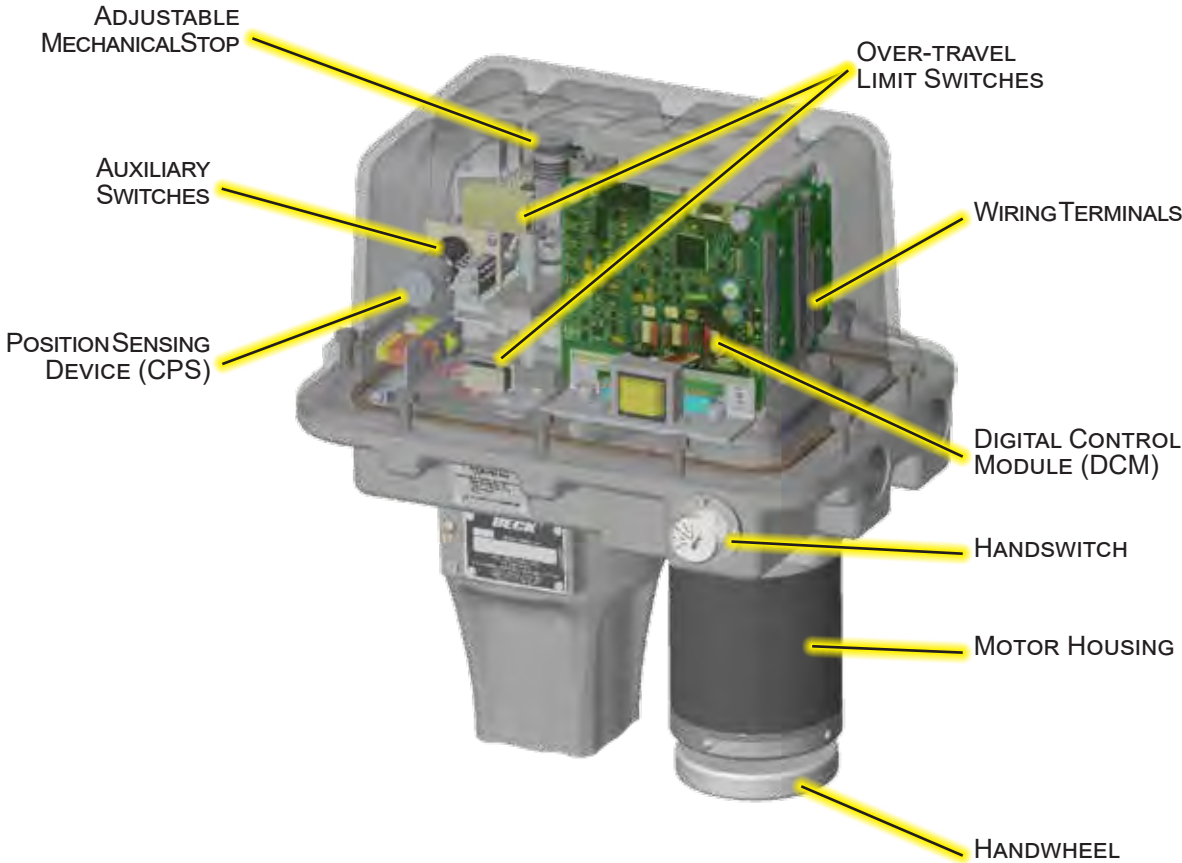

Model 29 Components

Handwheel

Group 29 actuators can be manually operated, without power, by a Handwheel attached directly to the motor shaft.

Self-Locking Mechanism (SLM)

The SLM is a coupling that transmits motor torque to the gear train, but instantly locks in place when the motor is de-energized; thus preventing back-driving due to dynamic valve load.

Tight-Seater™

This unique device ensures that the valve is positively seated at the closed position.

Housing

Beck actuators feature a cast aluminum body with individual compartments to protect components from moisture and dirt, and allow easy access for installation and calibration.

- Precision-machined aluminum alloy castings with corrosion-resistant polyurethane paint provide a rugged, dust-tight, weatherproof Type 4X enclosure.
- Class I, Division 1 and Class II, Division 1 & 2 rated versions are available.
- Gasketed covers provide extra protection for harsh environments.
- Output and Handwheel shafts are sealed with weatherproof, double-lip seals.

Mounting Versatility

Beck actuators are configured and lubricated in such a way that they may be mounted in any convenient position. This flexibility allows actuators to be installed in hard-to-fit locations.

As long as housing compartments remain accessible, there are no mounting orientation restrictions.



Control & Operating Features

In addition to controlling the precise modulation of the actuator, the advanced Digital Control Module (DCM) provides a host of features and functions, including:

- Compatibility with common asset management systems.
- Two-way digital communications.
- Simple calibration and setup without any mechanical or electrical adjustments.
- Linear, square or 20-segment custom input signal characterization.
- Actuator diagnostics and operating statistics available locally or remotely.
- Configurable action on loss of Demand input signal.
- Stall protection with configurable stall time setting.



CONTROL OPTIONS & SAMPLE WIRING DIAGRAMS

Diagrams are functional—customer wiring may vary. Certified wiring diagrams can be provided for the actuator you select.

Modulating Option 9

Digital Position Control with
Contactless Position Sensing

The Beck DCM positions the actuator in proportion to an input current or voltage signal, and the CPS provides integral feedback for the DCM. A 4–20 mA position feedback signal is available for remote indication.

The DCM may be used to provide pre-determined positioning of the actuator upon loss of input control signal.

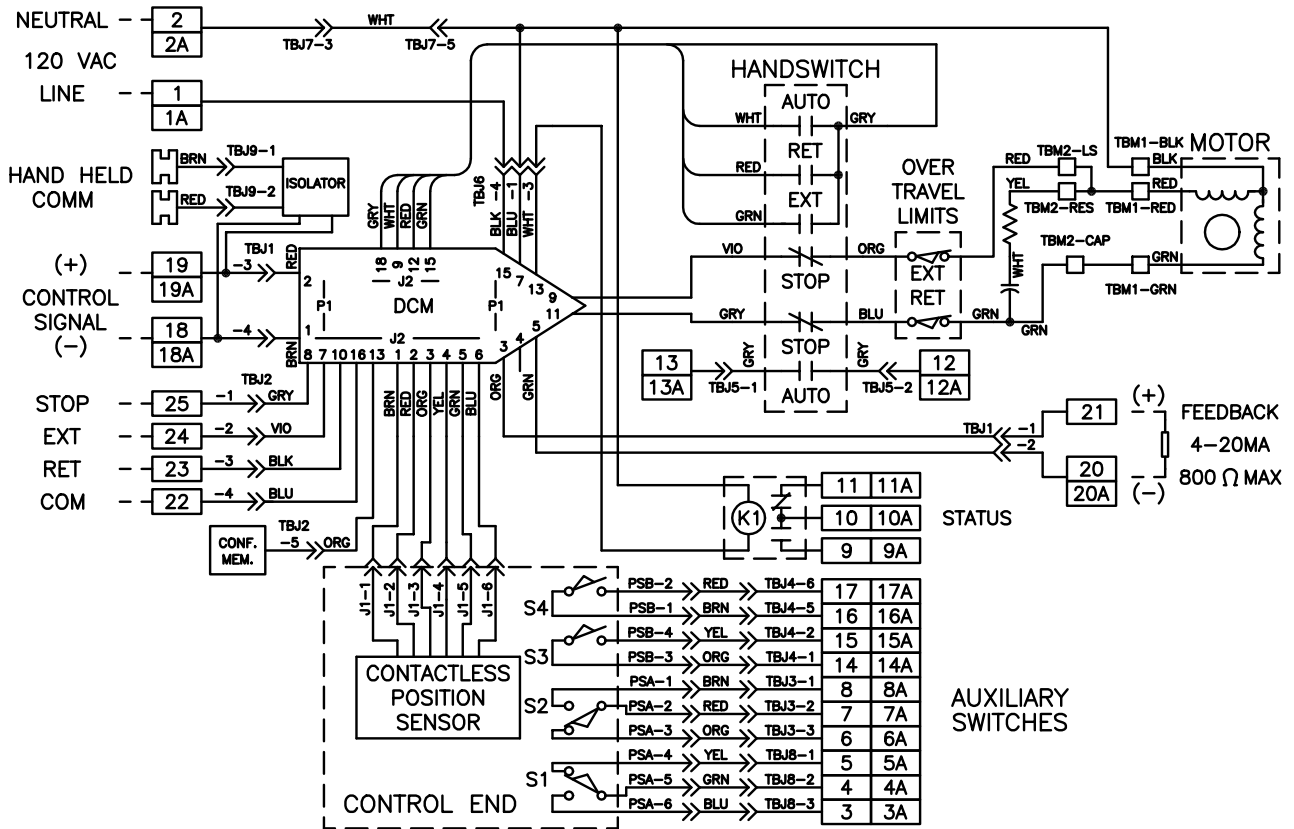

Open / Close Option 3

Direct AC Control

For simple open / close operation, Option 3 includes two limit switches, which stop the actuator at each end of travel and may also be used for external signaling.

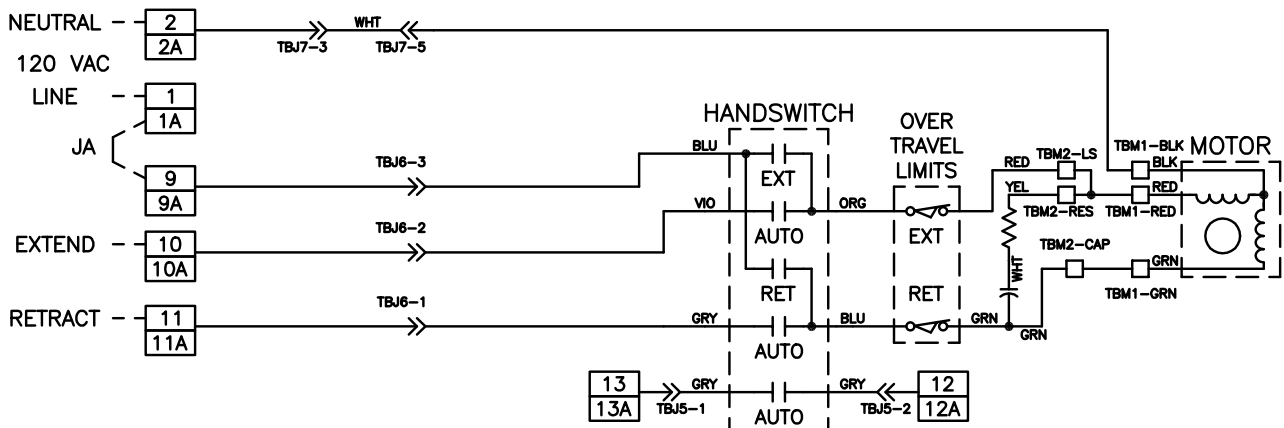

SPECIFICATIONS

Control Options

Control Option	Control Mode	Control Input Ranges	Position Sensor	Position Feedback	Aux. Switches (Cust. Use)
9	Modulating (DCM)	4–20 mA, 1–5 Vdc, Digital (fieldbus)	CPS	4–20 mA, Digital (fieldbus)	4
3	2-position (open/close)	120 Vac	None	None	4

Output Thrust and Timing

Model No.	Thrust (lbs.) [N]	Stroke Timing* (sec./in.) [sec./cm]	Min. Stroke Length (in.) [mm]	Max. Stroke Length (in.) [mm]
29-100	1000 [4450]	10 [3.9]	0.50 [13]	2 [51]
29-250	1700 [7565]	10 [3.9]	0.50 [13]	2 [51]
29-250	2100 [9345]	12.4 [4.9]	0.50 [13]	2 [51]
29-250	2700 [12015]	15 [5.9]	0.50 [13]	2 [51]
29-600	2100 [9345]	9.4 [3.7]	0.75 [19]	4 [102]
29-600	2600 [11570]	11.6 [4.6]	0.75 [19]	4 [102]
29-600	3200 [14240]	14 [5.5]	0.75 [19]	4 [102]
29-600	4100 [18245]	9.4 [3.7]	0.75 [19]	4 [102]
29-600	5000 [22250]	11.6 [4.6]	0.75 [19]	4 [102]
29-600	6100 [27145]	14 [5.5]	0.75 [19]	4 [102]

*Timings based on 60Hz power; 50Hz timing = 1.2 x 60Hz timing

<p>Input Power 120 Vac, single-phase 50 or 60 Hz; 240 Vac, single-phase 50 or 60 Hz</p> <p>Maximum Current and Power 29-100 -- 0.65A, 78W @ 120 Vac; 0.33A, 78W @ 240 Vac 29-250 -- 1.4A, 170W @ 120 Vac; 0.70A, 170W @ 240 Vac 29-600 -- 2.2A, 260W @ 120 Vac; 1.1A, 260W @ 240 Vac</p> <p>Operating Conditions –40° to 185°F (–40° to 85°C)</p> <p>Isolation Demand Input and Position Feedback signals are isolated from the ground and the ac power line.</p> <p>Action on Loss of Power Stays in place.</p> <p>Control Types (see chart above) Option 9, Modulating with Digital Control Module (DCM) & Option 3, 2 position (open/close) control</p> <p>Input and Feedback Signals 4–20 mA, 1–5 Vdc (Option 9 actuators only)</p> <p>Available Communication Protocols (control option 9) HART® (standard). Options: Foundation Fieldbus, Profibus PA and Modbus RTU.</p> <p>Minimum Step (Modulating Control) 0.10% configurable (0.15% default setting)</p> <p>Stall Protection (protects drive and driven elements under stall conditions) Time to stall is configurable from 30 to 300 seconds (option 9 drives).</p> <p>Action on Loss of Input Signal (Power On) Stays in place or, with option 9 drives, is field configurable to move to any preset position.</p> <p>Over-thrust Protection If actuator output thrust exceeds 150% (configurable to 70%) of the drive rating, the motor will shut off (feature can be enabled / disabled)</p> <p>Over-travel Limit Switches (Dedicated) Two Form C switches (one for each direction of travel) provide over-travel protection.</p> <p>Auxiliary Switches (Non-dedicated) Two Form C and two Form A, rated for 1A, 250 Vac. Switches are field-adjustable.</p> <p>Handswitch Permits local electrical operation independent of the controller signal. Standard on all units. A provided auxiliary contact can be used to indicate that the Handswitch is in "AUTO" mode or to sound an alarm if it is taken out of "AUTO". A locking Handswitch is also available.</p> <p>Enclosure Precision-machined, aluminum alloy castings painted with corrosion-resistant polyurethane paint provide a rugged, dust-tight, weatherproof enclosure. Type 4, 4X; IP66.</p> <p>Standards CSA Labeled (US & Canada); CE Compliant NOTE: For standards not specifically listed, please call Beck for more information at 215-968-4600.</p> <p>Hazardous Locations (Optional) Class I, Div. 1, Groups C & D; Class I, Div. 2, Groups C & D; Class II, Div. 1, Groups E, F & G; Class II, Div. 2, Groups F & G; Class III, Div. 1 & 2. NOTE: May not be available with all options & models. If ratings do not meet your requirements, call Beck at 215-968-4600.</p>
--

OUTLINE DIMENSION DRAWINGS

Model 29-100

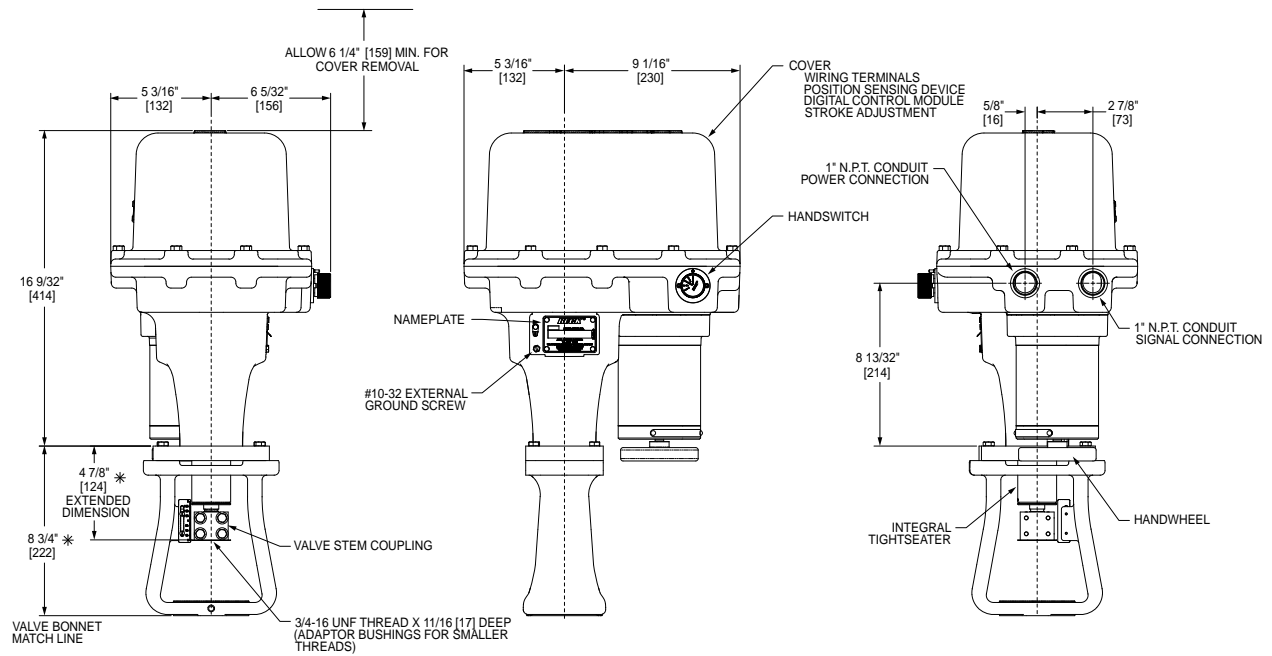

* Typical mounting feature will vary per application.

ACTUATOR STEM TRAVEL RANGE = 1/2"-2" [13-51 mm]; APPROX. WEIGHT = 94 lbs [43 kgs]

Model 29-250

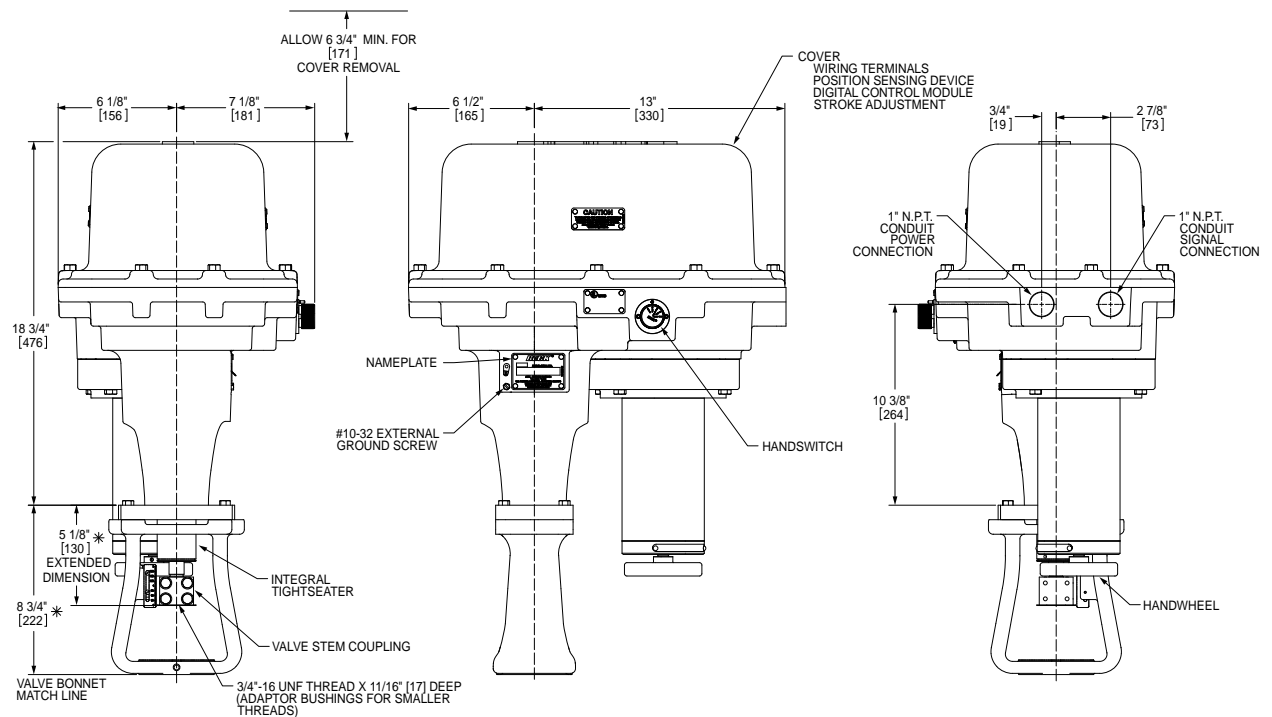

* Typical mounting feature will vary per application.

ACTUATOR STEM TRAVEL RANGE = 1/2"-2" [13-51 mm]; APPROX. WEIGHT = 152 lbs [69 kgs]

Model 29-600

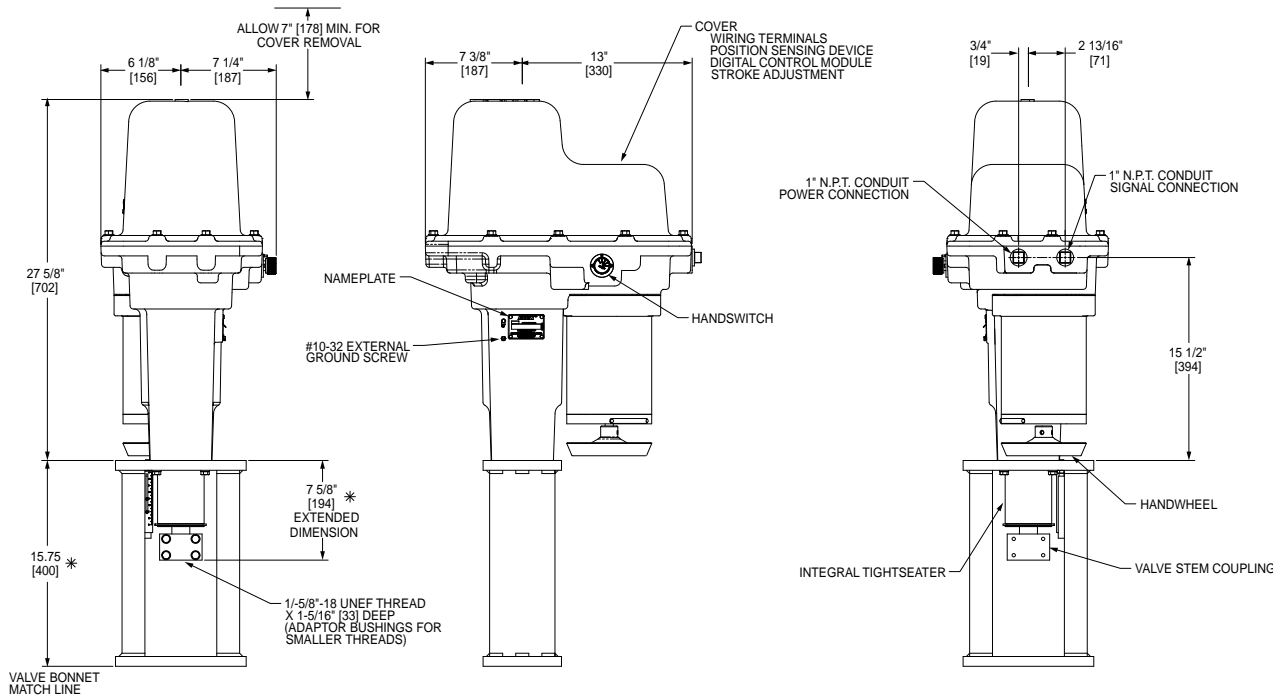

* Typical mounting feature will vary per application.

ACTUATOR STEM TRAVEL RANGE = 3/4"-4" [19-102 mm]; APPROX. WEIGHT = 220 lbs [100 kgs]

Actuators may be mounted in any orientation.

All dimensions are subject to change. Request certified dimensional drawings for the actuators you select.





GROUP 42

LINEAR ACTUATOR

Long-stroke actuator providing up to 1,000 lbs. of thrust, ideally suited for burner air register type applications

Designed for long linear stroke applications, the Group 42 offers simplicity, flexibility and an easy-to-use package. Ideally suited for burner air register type applications, the Group 42 is flexible and can be used on many long linear stroke applications.

The Group 42 is available with digital modulating control utilizing the Beck Digital Control Module (DCM) allowing all the advanced features, such as HART® capability, offered by microprocessor-based electronics.

The Group 42 is also available with modulating analog control or direct AC control.

Ideally suited for harsh industrial environments, the Group 42 handles long stroke applications requiring up to 1,000 lbs. of thrust (4450 N). The design employs a highly efficient ball screw coupled with a time-proven Beck motor and offers consistent, repeatable positioning as precise as 0.1% of span. Like all Beck actuators, the Group 42 incorporates a heavy-duty, weather-proof, cast aluminum body.



May be mounted in any orientation.

FEATURES

Gear Train

Performance and Durability

The Group 42 drive train is designed for high-efficiency, consistent performance and durability. Typical linear electric actuators employ less efficient technologies such as worm gears and screws, which can be subject to wear and inconsistent positioning performance. In contrast, the highly efficient Group 42 drive train consists of spur gears coupled to a ball screw. This design improves performance and reliability and reduces maintenance requirements.

Self-Locking Mechanism (SLM)

Back-driving Protection

A self-locking mechanism is an integral part of the Group 42 drive system. The SLM is a coupling that transmits motor torque to the drive train, but instantly locks in place when the motor is de-energized; this prevents back-driving resulting from a dynamic load.

Manual Operation

Convenient Local Operation

The Group 42 actuator can be manually operated, without power, by a Handwheel directly connected to the drive motor shaft. This allows positioning of the driven load in the absence of AC power.

Clevis Mounting

Easy Installation and Set up

The Group 42 utilizes a clevis style mounting that is both rugged and simple to use. The clevis mounting provides the flexibility to easily adapt the actuator to most applications. Custom clevis extensions and hole sizes are available.

Weatherproof Design

The Group 42 is designed to meet Type 4X requirements. The heavy aluminum body casting provides superior durability and corrosion resistance.

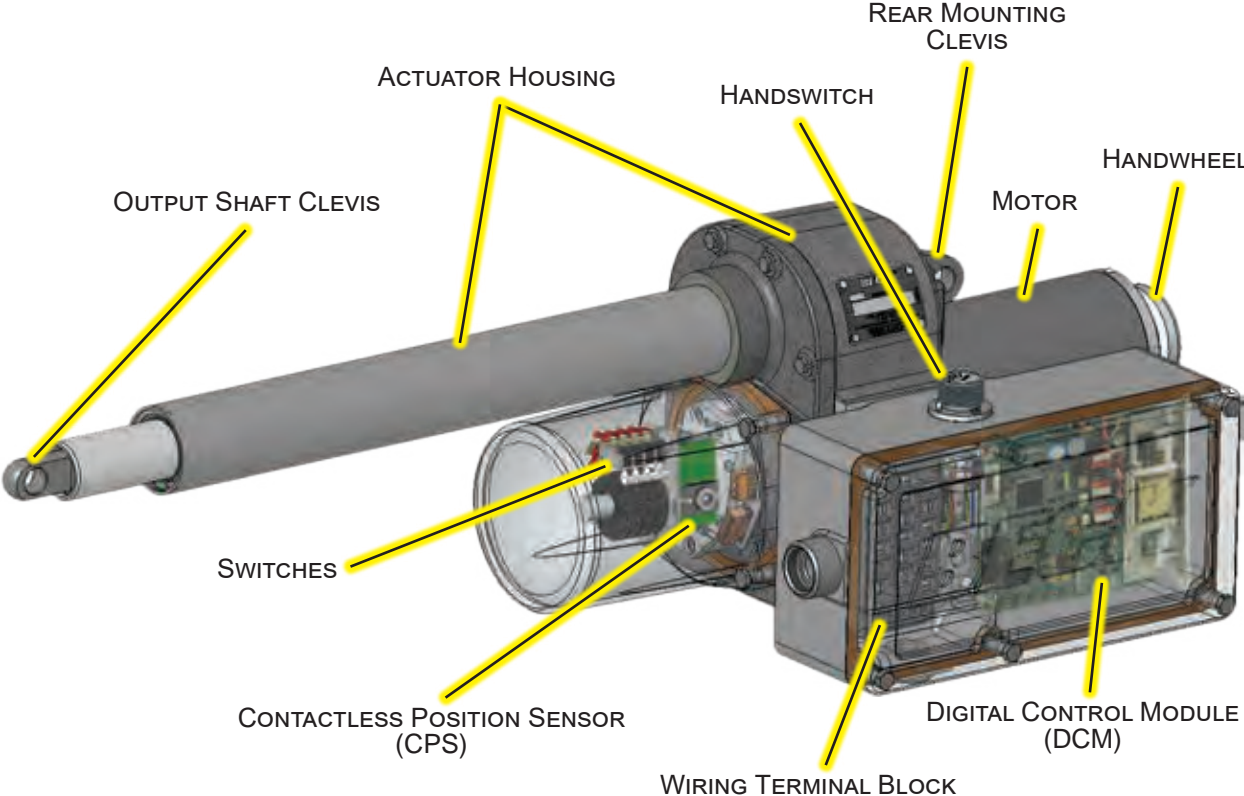

GROUP 42 ACTUATOR COMPONENTS (Model 42-109 shown)

Motor

No Burnout

Beck actuators utilize a low current draw, continuous duty motor design. This motor ensures the actuator will not coast or overshoot and will not overheat—even under continuous modulation. The net result is consistent, repeatable positioning with no duty limitations.

Thrust Sensing

Live output thrust sensing and protection is standard on Option 9 versions of the Group 42.

Handswitch

Complete Local Control

The Group 42 is equipped with an override manual Handswitch to aid in the setup and installation of the actuator independent of external control signals.

Auxiliary Switches

Easily Adjustable Trip Points

Up to two optional non-dedicated Form C switches are available. These switches are cam-operated and easily adjusted in the field. Wiring connections are provided in the actuator terminal compartment to allow easy access.

Control & Operating Features

Group 42 actuators are available in several different control configurations including:

Control Option 9: 4-20 mA modulating with a Digital Control Module (DCM), Contactless Position Sensor (CPS) and thrust sensing. This version includes both HART communications capabilities and local setup/diagnostic interface for simple calibration, setup and diagnostic capabilities.

Control Option 7: 4-20 mA modulating with analog electronics and position feedback. This version has time-proven analog electronics on-board for simple, reliable no frills positioning and feedback of the actuator.

Control Option 5: 120 Vac pulsed option. This version allows direct AC control of the actuator's motor for either PAT type modulation or simple multi-position control.

Control Option 3: For simple open/close operation. Includes 2 limit switches which stop the actuator at each end of travel and may also be used for external signaling.

All Group 42 actuators are capable of providing consistently excellent modulating or multi-position control. They also provide easy access, installation and setup. Depending on the control option selected, the Group 42 can reliably position with steps as small as 0.1% of stroke. Actuators equipped with the DCM provide the best positioning performance and the most operating features. DCM equipped actuators include the following features:

- Live thrust measurement and over-thrust protection.
- Two-way digital communications via HART protocol.
- Simple calibration and setup without electrical or mechanical adjustments.
- Actuator diagnostic capabilities.
- Configurable action on loss of demand signal.
- Stall protection with configurable stall time setting.
- Operating variables including thrust, position, and actuator temperature are available via HART.
- The ability to restore all actuator calibration and setup parameters to factory “as-built” settings.



42-109



42-107

CONTROL OPTIONS & SAMPLE WIRING DIAGRAMS

Diagrams are functional—customer wiring may vary. Certified wiring diagrams can be provided for the actuator you select.

Modulating Option 9

Digital Position Control with Contactless Position Sensing

The Beck DCM positions the actuator in proportion to an input current or voltage signal, and the CPS provides integral feedback for the DCM. A 4–20 mA position feedback signal is available for remote indication.

The DCM may be used to provide pre-determined positioning of the actuator upon loss of input control signal.

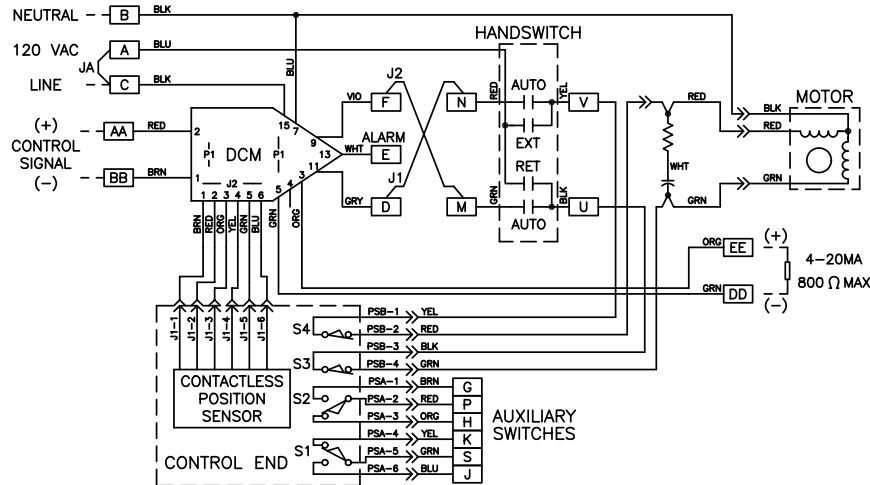

Modulating Option 7

Analog Position Control with Loop Powered Position Feedback Signal

Customer must supply two wires to power the actuator: One 120 Vac line (terminal 1), and one neutral (terminal 2). Customer must supply two wires for the analog input control signal: Connect to terminal 11 (-) and to terminal 12 (+). The loop powered position feedback signal must be connected to a "2-wire" type analog input that provides a dc voltage over the signal wires (a dc voltage power supply must be wired in series with the signal wiring). If the dc supply is 24 to 35 volts, connect to terminal 14 (-) and to terminal 15 (+). If the dc power supply is 36 to 45 volts, reverse polarity and connect to terminal 14 (+) and to terminal 15 (-).

Analog Position Control with Actuator Powered Position Feedback Signal

Customer must supply two wires to power the actuator: One 120 Vac line (terminal 1), and one neutral (terminal 2). Customer must supply two wires for analog control: Connect to terminal 11 (-) and to terminal 12 (+). Customer may supply two additional wires to monitor the analog position feedback signal: Connect to terminal 13 (-) and to terminal 14 (+). The actuator's feedback circuit power supply is derived from the 120 Vac line, therefore the feedback signal must be wired to a "4-wire" type, non-powered analog input.

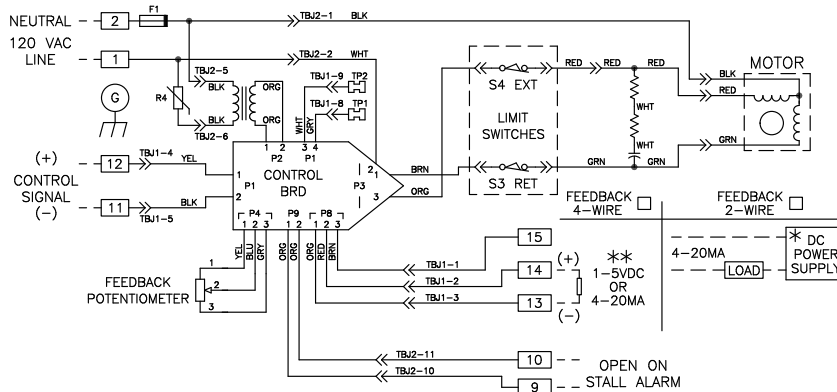

Modulating Option 5

Direct AC Control with Actuator Powered Position Feedback Signal

Customer must supply three wires to directly control the actuator motor direction: One 120 Vac line to run Extend (terminal 10), one 120 Vac line to run Retract (terminal 9), and one neutral (terminal 2). Customer may supply two additional wires to monitor the analog position feedback signal: Connect to terminal 13 (-) and to terminal 14 (+). If position feedback monitoring is desired, a 120 Vac line must be connected to terminal 1. The actuator's feedback circuit power supply is derived from this 120 Vac line, therefore the feedback signal must be wired to a "4-wire" type, non-powered analog input.

Direct AC Control with Loop Powered Position Feedback Signal

Customer must supply three wires to directly control the actuator motor direction: One 120 Vac line to run Extend (terminal 10), one 120 Vac line to run Retract (terminal 9), and one neutral (terminal 2). Customer may supply two additional wires to monitor a loop powered position feedback signal. The loop powered position feedback signal must be connected to a "2-wire" type analog input that provides a dc voltage over the signal wires (a dc voltage power supply must be wired in series with the signal wiring). If the dc supply is 24 to 35 volts, connect to terminal 14 (-) and to terminal 15 (+). If the dc supply is 36 to 45 volts, reverse polarity and connect to terminal 14 (+) and to terminal 15 (-).

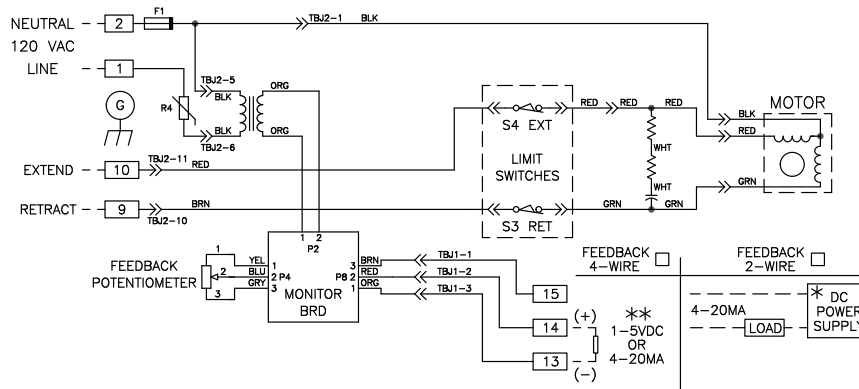

Option 3, Open/Close

Direct AC Control

Customer must supply three wires to directly control the actuator motor direction: One 120 Vac line to run Extend (terminal 10), one 120 Vac line to run Retract (terminal 9), and one neutral (terminal 2).

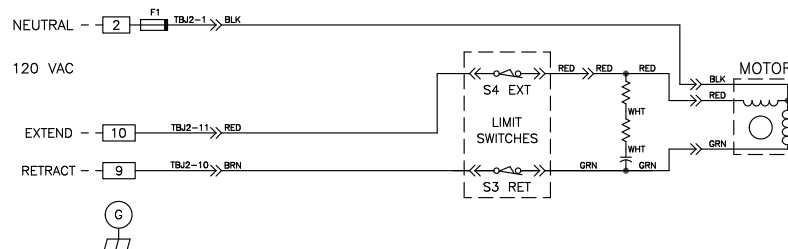

SPECIFICATIONS

MODEL 42-109

Output Thrust and Timing 1,000 lbs. (4450 N), 4.2 sec./in. (1.65 sec./cm)
Stroke Range 5 to 18 inches (127 to 457 mm)
Actuator Power 120 Vac, single-phase, 50 or 60 Hz, 1.3 A 240 Vac, single-phase, 50 or 60 Hz, .63 A—optional 208, 380, 415, 480, 575 Vac, 50 or 60 Hz—requires optional transformer
Weight Approx. 75–89 lbs. (34 to 40 kg), depending on selected options
Operating Conditions –40° to 85° C. (–40° to 185° F.); 0 to 99% relative humidity
Available Communication Protocols HART® (standard). Options: Foundation Fieldbus, Profibus PA and Modbus RTU.
Demand Input Signal Range 4–20 mA, 1–5 Vdc
Minimum Step 0.1% of span
Demand Input Signal Characterization Linear: Actuator output shaft moves proportionally to the input signal Square: Actuator output shaft moves proportionally to the square of the input signal Custom: 20 segment configurable curve fit
Position Feedback Signal 4–20 mA
Isolation Demand input and position Feedback signals are isolated from ground and the ac power line. Signal buffering provides 24 Vdc isolation between the Demand and Feedback signals
Action on Loss of Input Signal (Power On) Stays in place or runs to any preset position (configurable)
Over-thrust Protection If actuator output thrust exceeds 150% (configurable to 70%) of the actuator rating, the motor will shut off (feature can be enabled / disabled)
Stall Protection If the motor tries to run in one direction for more than 300 seconds (configurable from 30 to 300 seconds), the motor will shut off
Over-travel Protection Switches (Dedicated) Two Form C (Retract and Extend) provide over-travel protection
Auxiliary Switches (Non-dedicated) Two Form C, rated for 1 A, 250 Vac
Handswitch Permits local electrical operation, independent of Demand input signal
Handwheel Provides manual operation without electrical power
Approvals CSA Labeled (US & Canada); CE Compliant <i>NOTE: For standards not specifically listed, please call Beck for more information at 215-968-4600.</i>
Enclosure Precision-machined aluminum alloy, painted with corrosion-resistant polyurethane paint, to provide a rugged, dust-tight, weatherproof enclosure designed to meet Type 4, 4X; IP66.
Mounting Orientation Can be mounted in any orientation
Hazardous Locations (Optional) Class II, Div. 1, Groups E, F & G; Class II, Div. 2, Groups F & G; Class III, Div. 1 & 2. <i>NOTE: May not be available with all options & models. If these ratings do not meet your requirements, call Beck at 215-968-4600.</i>

MODEL 42-107 & 42-105

Output Thrust and Timing 1,000 lbs. (4450 N), 4.2 sec./in. (1.65 sec./cm)
Stroke Range 5 to 18 inches (127 to 457 mm)
Actuator Power 120 Vac, single-phase, 50 or 60 Hz, 1.3 A
Weight Approx. 64–69 lbs. (29 to 31 kg), depending on selected options
Operating Conditions –40° to 85° C. (–40° to 185° F.); 0 to 99% relative humidity
Control Options 1) Modulating analog control (Option 7); 2) Direct ac control (Option 5)
Demand Input Signal (Option 7) 4–20 mA, 1–5 Vdc
Deadband 1.0% of span
Minimum Step .25% of span
Position Feedback Signal 4–20 mA, 1–5 Vdc Feedback may be configured as a two wire transmitter or as a four wire active signal source. Two wire systems require a customer supplied external power supply. Four wire systems require 120 Vac supply to the drive.
Isolation Demand input and position Feedback signals are isolated from ground and the ac power line. Signal buffering provides 24 Vdc isolation between the Demand and Feedback signals.
Action on Loss of Power Stays in place
Action on Loss of Demand Input Signal (Option 7) Stays in place or moves to predetermined position with ac power supplied
Stall Protection (Option 7) If the motor tries to run in one direction for more than approx. 2 minutes, it will shut off
Stall Relay Contacts (Option 7) Form A, 10 volt-amps at 120 Vac or dc
Action on Stall (Option 7) Motor power is turned off when relay contacts open (after 136 seconds of stall) -- remote signal available
Over-travel Limit Switches (Dedicated) Two Form C (Retract and Extend), field adjustable
Auxiliary Switches (Non-dedicated) Two Form C, rated for 1 A, 250 Vac, field adjustable
Handswitch (Option 7) Permits local electrical operation, independent of Demand input signal
Handwheel Provides manual operation without electrical power
Approvals CSA Labeled (US & Canada); CE Compliant <i>NOTE: For standards not specifically listed, please call Beck for more information at 215-968-4600.</i>
Enclosure Precision-machined aluminum alloy, painted with corrosion-resistant polyurethane paint, to provide a rugged, dust-tight, weatherproof enclosure designed to meet Type 4, 4X; IP66.
Mounting Orientation Can be mounted in any orientation
Hazardous Locations (Optional) Class II, Div. 1, Groups E, F & G; Class II, Div. 2, Groups F & G; Class III, Div. 1 & 2. <i>NOTE: May not be available with all options & models. If these ratings do not meet your requirements, call Beck at 215-968-4600.</i>

OUTLINE DIMENSION DRAWINGS

Model 42-109

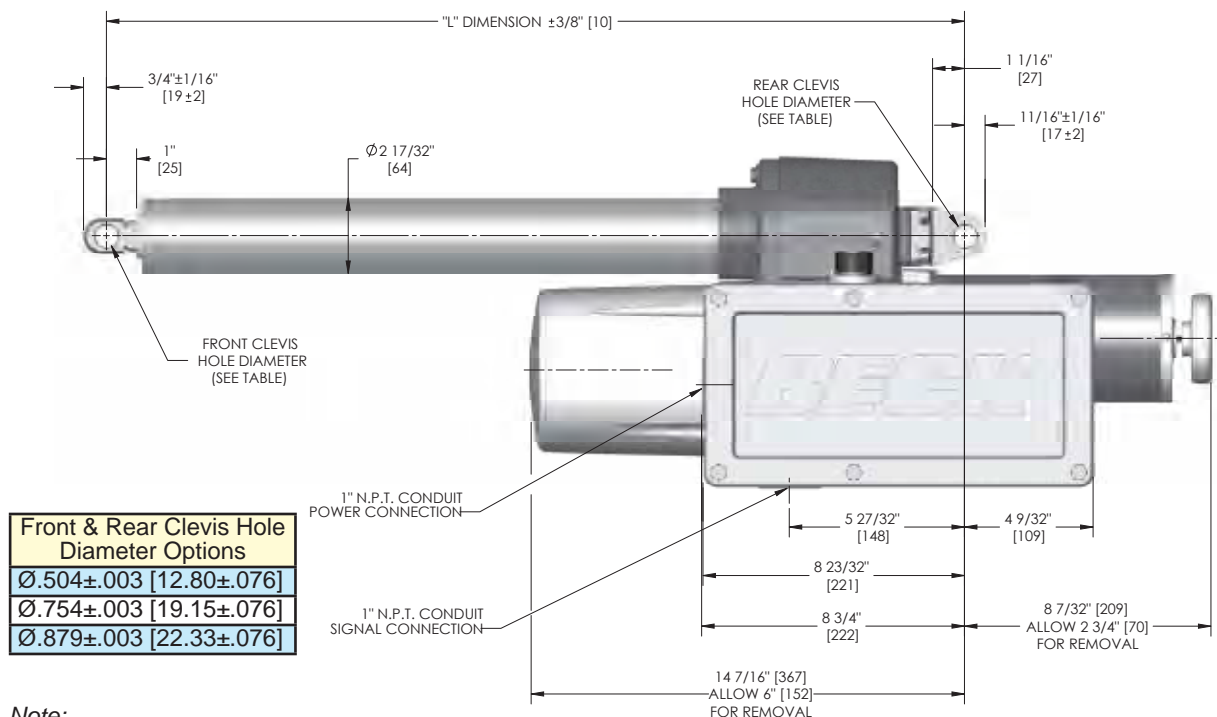

Front & Rear Clevis Hole Diameter Options	
Ø.504±.003	[12.80±.076]
Ø.754±.003	[19.15±.076]
Ø.879±.003	[22.33±.076]

Note:
 Front mounting clevis rotates 360°.
 Custom rear clevis extensions are available.

SIDE VIEW

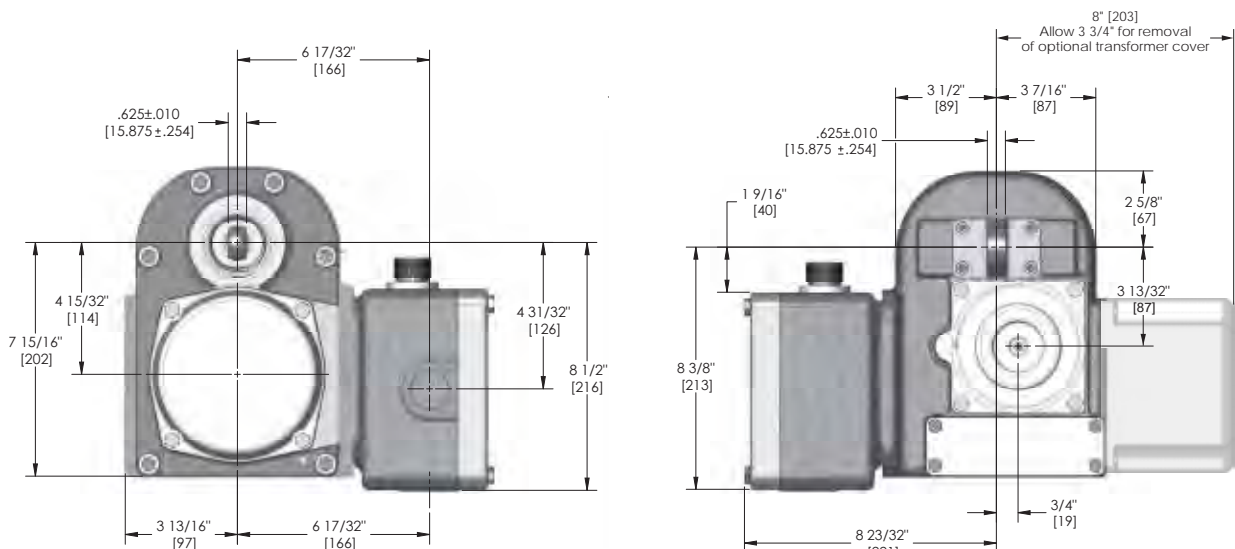

FRONT VIEW

REAR VIEW

Drive Travel		"L" dim. fully retracted in. [mm]	"L" dim. fully extended in. [mm]	Approx. Wt. (120 V) lb. [kg]	Approx. Wt. (240 V) lb. [kg]
Max. in. [mm]	Min. in. [mm]				
8 [203]	5 [127]	18 19/32 [472]	26 19/32 [675]	75 [34]	84 [38]
12 [305]	7 [178]	22 19/32 [574]	34 19/32 [879]	77 [35]	86 [39]
18 [457]	11 [279]	28 19/32 [726]	46 19/32 [1 183]	80 [36]	89 [40]

Drives may be mounted in any orientation.

All dimensions are subject to change. Request certified dimensional drawings for the drives you select.

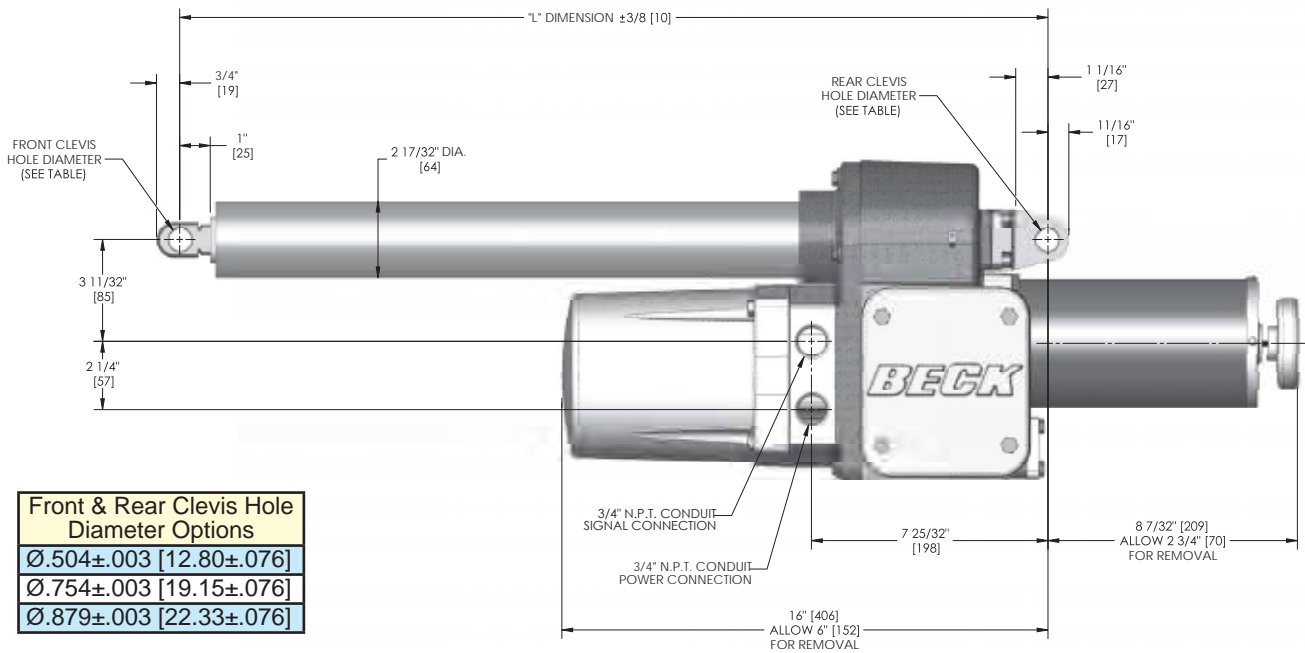

Front & Rear Clevis Hole Diameter Options	
Ø.504±.003	[12.80±.076]
Ø.754±.003	[19.15±.076]
Ø.879±.003	[22.33±.076]

Note:
 Front mounting clevis rotates 360°.
 Custom rear clevis extensions are available.

SIDE VIEW

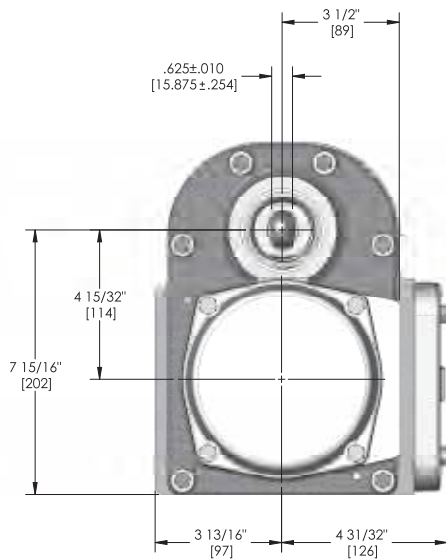

FRONT VIEW

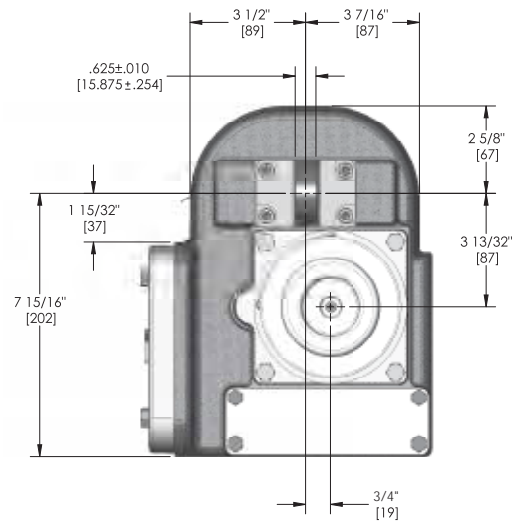

REAR VIEW

Drive Travel		"L" dim. fully retracted in. [mm]	"L" dim. fully extended in. [mm]	Approx. Wt. (120 V) lb. [kg]
Max. in. [mm]	Min. in. [mm]			
8 [203]	5 [127]	18 19/32 [472]	26 19/32 [675]	64 [29]
12 [305]	7 [178]	22 19/32 [574]	34 19/32 [879]	66 [30]
18 [457]	11 [279]	28 19/32 [726]	46 19/32 [1 183]	69 [31]

Drives may be mounted in any orientation.

All dimensions are subject to change. Request certified dimensional drawings for the drives you select.

SPECIALTY APPLICATIONS

Whatever the application, there is a Beck actuator available to improve efficiency and reliability.

Burner Tilts

The Beck 11-430 Electric Actuator provides up to 5,200 lb-ft [7 046 N•m] of torque for modulation of large dynamic loads such as multiple burner tilt arrays and large dampers. All of the flexibility, convenience, and reliability that distinguish Beck actuators are included in the 11-430 high torque actuator. To produce the 11-430, a Beck 11-400 actuator is mated with a large, durable gear reduction unit that increases the output torque by a factor of 3:1. The output shaft and crank arm have been designed to conservatively deliver this greater torque. The actuator is available with four different torque/timing options. See page 16 for details.



Variable Speed Couplings

Beck Group 11 actuators are ideal for use with variable speed applications such as fluid drives and magnetic couplings. They provide exceptional stability and repeatability under live loads.

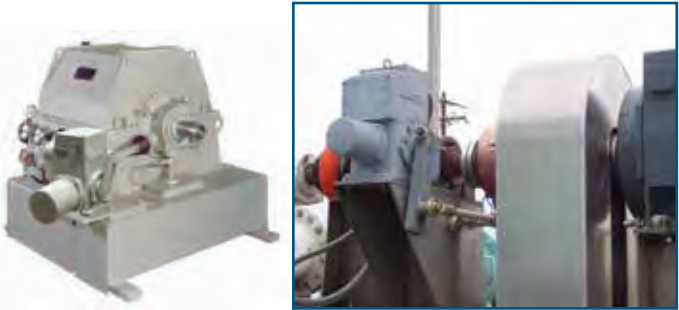

Hazardous Location Actuators

Most Beck actuators are available rated for use in hazardous locations, allowing for utilization in refineries on heaters and gas valves, as well as other hazardous areas. Contact Beck's Sales Dept. or visit <http://www.haroldbeck.com> for more details.



Pump Handle Valves

Beck Group 11 actuators with fulcrum lever mountings provide accurate modulating control of large linear globe valves. These virtually maintenance-free assemblies reliably eliminate stick/slip and performance inconsistencies typical of pneumatic actuators. The fulcrum lever assembly accommodates high thrusts while maintaining long-term reliability and precision. In addition, Group 11 actuators are available with hazardous location ratings.



Gate Dampers

A multi-revolution Group 11 actuator is available for those applications in which a gravity-type gate must be raised or lowered in response to signal changes. Often used to regulate differential pressure by controlling balancing dampers on the hot exhaust side of furnaces, Beck actuators provide high accuracy and quick response even when continuously modulating. This results in greater fuel economy and longer refractory life.

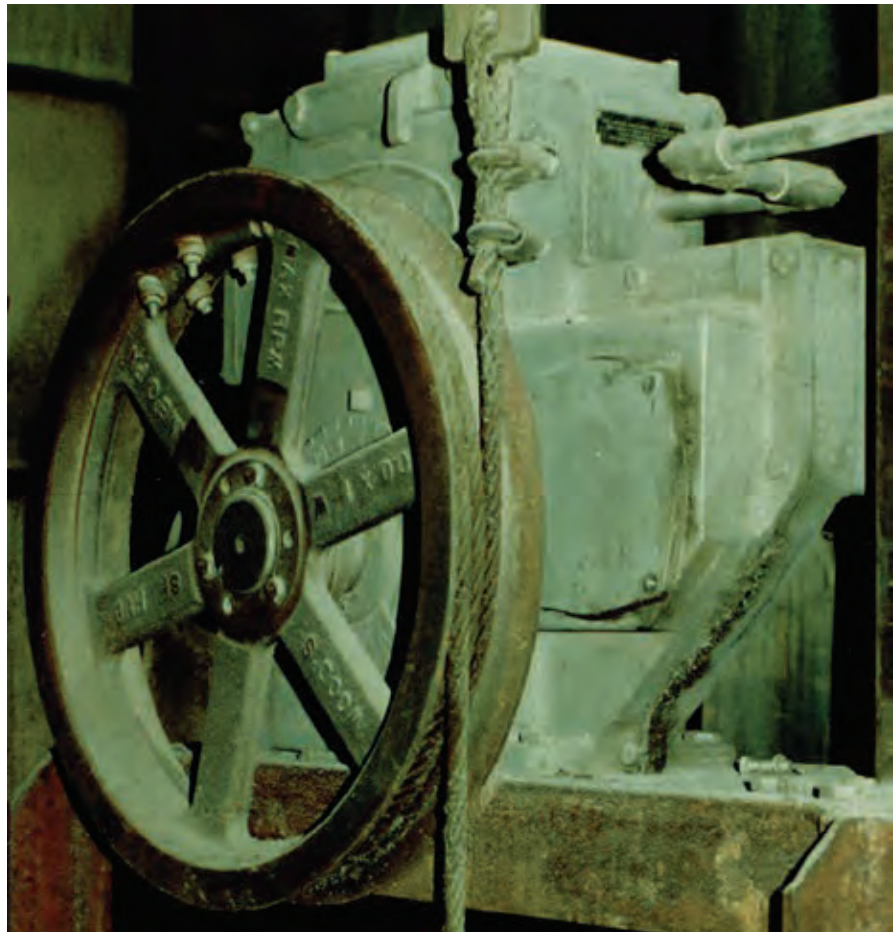

ACCESSORIES AND SERVICES

Beck offers a wide range of accessories, services and unparalleled customer support to ensure complete satisfaction

INSTALLATION ASSISTANCE

Our experience shows proper installation to be among the most important factors in achieving long-term, maintenance-free service from your Beck actuator. To ensure a trouble-free installation, we will work directly with you through each step—from actuator selection to final installation. We can assist you with each of the following:

- **Actuator Selection.** To specify the proper torque/thrust and timing.
- **Mounting Base Design.** Design a long-lasting installation that protects the actuator and driven equipment, and provides proper access clearances. Customized pedestals and adaptor plates are available.
- **Linkage Design.** Provide you with detailed linkage dimensions and linkage selection.
- **Retrofit Kits.** Update your actuator to include the latest advances.



Old pneumatic actuator



Beck replacement actuator



Linkage Kits

Beck Linkage Kits are available for completing the mechanical connection from the actuator crank arm to the load lever arm. Proper linkage connection is an important consideration in achieving a successful, long-lasting installation. By eliminating slop in the linkage, control is improved. Beck Sales Engineers can assist you with designing your linkage and specifying the appropriate linkage kit.

Beck Linkage Kits are designed to simplify installation of your Beck actuator on any application. All Kits are provided with internal left-hand and right-hand threads to permit adjustment of linkage length of $\pm 1 \frac{1}{2}$ " [38 mm] without removal from the crank arm or load lever arm.

Rod ends with bearings are used to provide long term reliability, virtually eliminate binding and wear, and provide tight control of the driven load. These rod ends allow for some lateral misalignment between the actuator shaft and driven load which simplifies installation.



Link-Assist™

The Link-Assist™ computer program optimizes the configuration for the load's torque characteristics with the minimum actuator size to give you the best performance at the lowest possible cost. Link-Assist™ is available for the proper selection of the rotary actuator torque rating and linkage system for your valves and dampers.

Beck Group 11 actuators may be specified to travel 100 degrees—regardless of full travel of the driven equipment—for enhanced control of damper or valve position. This feature also allows full flexibility in arranging the actuator's torque to be distributed for the best mechanical advantage relative to the driven load. Full 100° actuator travel also provides the highest position resolution attainable using the full travel of the CPS feedback device.

To take advantage of Beck's Link-Assist™ program, provide the following information to your Beck Sales or Application Engineer:

- Load torque characteristics, including maximum torque and load arm angular position
- Load lever radius (and range, if adjustable)
- Load lever shaft rotation range
- Approximate load shaft to drive shaft center distance
- Any space limitations, mechanical interferences or mounting conditions.

You will receive the following data for your review:

- Load shaft torque profile
- Linkage length
- Load and actuator crank arm radii
- Load and actuator crank arm angular rotation range
- Link force
- Recommended Beck actuator and linkage kit
- Data sheets to help collect and record the data are available by calling the factory or visiting our website: http://www.haroldbeck.com/support/linkage_link-assist.htm



Scan
for
Video



SAMPLE LINK-ASSIST DATA SHEET

HAROLD BECK AND SONS, INC.

June 29, 2007

Newtown, PA 18940

Contact: BECK Sales Engineer 215-968-4600

YOUR Facility Information

References:
YOUR Desired Reference Info

LINK-ASSIST DATA SHEET

Note:
SAMPLE LINK-ASSIST REPORT

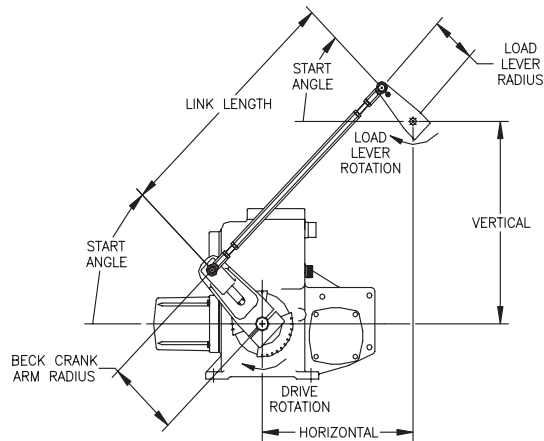

Note: Diagram is not drawn to scale - for reference only

BECK CONTROL DRIVE DATA

Model Number: 11-409
Rated Torque: 1800 lb-ft

LINKAGE DATA

Horizontal Offset. (H): 24.00 inches
Vertical Offset..... (V): 36.00 inches
Connecting Link Length (A): 44.13 inches

BECK CRANK ARM DATA

Required Rotation: 100 degrees
Start Position...: 1 degrees
Radius (C): 8.99 inches

LOAD LEVER ARM DATA

Required Rotation: 90 degrees
Start Position...: 10 degrees
Radius (L): 10.00 inches

CONTROL DRIVE CRANK ARM ROTATION Degrees	LOAD LEVER ARM ROTATION degrees	LOAD LEVER TORQUE lb-ft	LOAD LEVER/ CRANK ARM TORQUE RATIO	LINK FORCE lbs
0.0	0.0	2163	1.20	2792
10.0	8.5	2085	1.16	2572
20.0	17.2	2033	1.13	2449
30.0	26.2	1998	1.11	2403
40.0	35.2	1975	1.10	2429
50.0	44.4	1960	1.09	2531
60.0	53.6	1951	1.08	2726
70.0	62.8	1951	1.08	3053
80.0	72.0	1962	1.09	3592
90.0	81.1	1994	1.11	4533
100.0	90.0	2088	1.16	6420

2:39:00 PM

Hex Linkage Kits

When well-defined, short lengths are required, Hex Linkage Kits can be used. The table below provides information for specifying Hex Linkage Kits.

Hex Linkage Kits include:

- Load lever rod end (the actuator rod end is supplied with the Beck actuator)
- Hex Linkage
- Threaded Stud (2)
- Jam Nuts (4)

The customer must supply the bolt for the load lever rod end. Use a bolt that results in the minimum clearance in the rod end. See dimension "D" in the bottommost table below.



Hex Linkage Kit Specifications

Model	Hex Size	Linkage Length Range "A", in [mm]		Linkage Kit Part No.	Approx. Weight, lbs [kgs]
		Min.	Max.		
31-__	7/16	9 [229]	12 [305]	14-7990-22	.5 [.23]
		12 [305]	15 [381]	14-7990-24	.5 [.23]
		15 [381]	18 [457]	14-7990-26	.75 [.34]
		18 [457]	21 [533]	14-7990-10	1 [.45]
11-15_	5/8	9 [229]	11.5 [292]	14-8300-22	1 [.45]
		10.5 [267]	14.5 [368]	14-8300-32	1 [.45]
		14.5 [368]	18.5 [470]	14-8300-04	1 [.45]
		18 [457]	22 [559]	14-8300-06	2 [.91]
		22 [559]	26 [660]	14-8300-16	2 [.91]
11-20_	5/8	9 [229]	11.5 [292]	14-8300-22	1 [.45]
		10.5 [267]	14.5 [368]	14-8300-32	1 [.45]
		14.5 [368]	18.5 [470]	14-8300-04	1 [.45]
		18 [457]	22 [559]	14-8300-06	2 [.91]
		22 [559]	26 [660]	14-8300-16	2 [.91]
11-30_	1	13.5 [343]	18 [457]	14-8860-24	2 [.91]
		17.5 [445]	22 [559]	14-8860-08	3 [1.36]
		22 [559]	26.5 [673]	14-8860-02	4 [1.81]
		26.5 [673]	31 [787]	14-8860-04	5 [2.27]
11-40_	1	13.5 [343]	17.5 [445]	15-0110-26	3 [1.36]
		18 [457]	22 [559]	15-0110-20	4 [1.81]
		22 [559]	26 [660]	15-0110-03	5 [2.27]
		26 [660]	30 [762]	15-0110-22	6 [2.72]
		29 [737]	33 [838]	15-0110-02	6 [2.72]

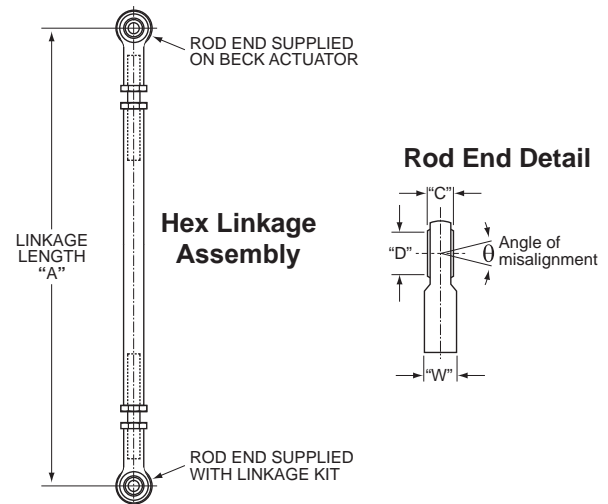

Linkage Rod End Data

Model	31-__	11-15_	11-20_	11-30_	11-40_	11-43_	22-__
Thread Size	5/16-24	1/2-20	1/2-20	5/8-18	3/4-16	1 1/2-12	1 1/2-12
Dim. "C", in. [mm]	.437 [11.1]	.625 [15.875]	.625 [15.875]	.750 [19.05]	.875 [22.225]	1.312 [33.324]	1.312 [33.324]
Dim. "D", in. [mm]	.3125 [7.938]	.500 [12.7]	.500 [12.7]	.625 [15.875]	.750 [19.05]	1.500 [38.1]	1.500 [38.1]
Dim. "W", in. [mm]	.437 [11.1]	.750 [19.05]	.750 [19.05]	.875 [22.225]	1.000 [25.4]	2.000 [50.8]	2.000 [50.8]
Angle θ	14°	12°	12°	16°	14°	6.5°	6.5°

Pipe Linkage Kits

Pipe Linkage Kits are necessary for heavier loads at lengths from 22" [559 mm] to 120" [3048 mm] and are designed in consideration of compression forces at maximum rated actuator torque outputs.

Pipe Linkage Kits include:

- Load lever rod end (the actuator rod end is supplied with the Beck actuator)
- Coupling (2)
- Threaded Stud (2)
- Jam Nuts (4)



The customer must supply the bolt for the load lever rod end. Use a bolt that results in the minimum clearance in the rod end. See dimension "D" in the table at the bottom of page 88.

The customer must also supply the length of pipe (using Schedule 40 pipe), which can be cut and threaded in the field. Standard NPT right-hand threads must be used on both ends of the pipe length. This arrangement allows the required kit to be ordered even if the exact linkage length is not known until the actuator and equipment are in place.

Ordering and Assembly

- Obtain the approximate overall linkage length "A" (see illustration below).
- Identify the kit part number and required pipe size from the table below. For lengths beyond those listed, contact your Beck Sales Engineer.
- Determine the pipe length required by subtracting "Length of 2 Linkage Ends" (see table below) from linkage length "A".
- The pipe length is to be cut and threaded in the field. The final linkage assembly permits $\pm 1 \frac{1}{2}$ " [38 mm] adjustment in the field.

Pipe Linkage Kit Specifications

Model	Linkage Length Range "A", in [mm]		Linkage Kit Part No.	Pipe Size, in [mm]	Min. Pipe Nipple Length, in [mm]	Approx. Weight, lbs [kgs]	Length of 2 Linkage Ends (Total Adj. ± 1.5 " [38 mm])
	Min.	Max.					
11-15_	22 [559]	84 [2134]	20-1730-05	1 [25]	1.5 [38]	5 [2]	20.5 [521]
	31 [787]	120 [3048]	20-1740-06	1.5 [38]	1.75 [44]	9 [4]	29.25 [743]
11-20_	22 [559]	45 [1143]	20-1730-05	1 [25]	1.5 [38]	5 [2]	20.5 [521]
	31 [787]	84 [2134]	20-1740-06	1.5 [38]	1.75 [44]	9 [4]	29.25 [743]
	33.25 [845]	120 [3048]	20-1750-05	2 [51]	2 [51]	13 [6]	31.25 [794]
11-30_	37 [940]	120 [3048]	20-1760-05	2.5 [64]	2.5 [64]	22 [10]	34.5 [876]
	22.5 [572]	36 [914]	20-1730-06	1 [25]	1.5 [38]	5 [2]	21 [533]
	31.5 [800]	72 [1829]	20-1740-07	1.5 [38]	1.75 [44]	9 [4]	29.75 [756]
	33.75 [857]	96 [2438]	20-1750-06	2 [51]	2 [51]	13 [6]	31.75 [806]
11-40_	37.5 [953]	120 [3048]	20-1760-06	2.5 [64]	2.5 [64]	22 [10]	35 [889]
	23.25 [591]	34 [864]	20-1730-07	1 [25]	1.5 [38]	5 [2]	21.75 [552]
	32.25 [819]	48 [1219]	20-1740-08	1.5 [38]	1.75 [44]	9 [4]	30.5 [775]
	34.5 [876]	72 [1829]	20-1750-07	2 [51]	2 [51]	13 [6]	32.5 [826]
11-43_ & 22-__	38.25 [972]	120 [3048]	20-1760-07	2.5 [64]	2.5 [64]	22 [10]	35.75 [908]
	23.5 [597]	40 [1016]	20-1760-13	2 [51]	2 [51]	28 [711]	21.5 [546]
	37.75 [959]	144 [3658]	20-1760-10	3 [76]	2.625 [67]	32 [813]	35.125 [892]
	59.75 [1518]	144 [3658]	20-1760-09*	3 [76]	2.625 [67]	41 [1041]	57.125 [1451]

*Use when the angle between the linkage and crank arm is less than 25°.

Pipe Linkage Assembly

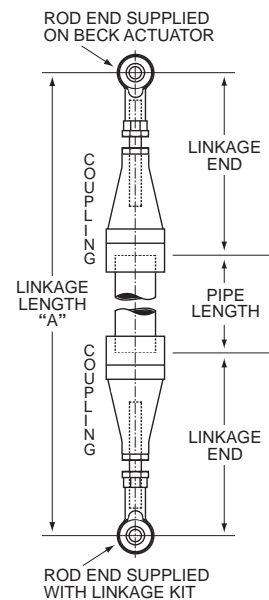

OPTIONS

Hazardous Location Ratings

Most Beck actuators are available CSA listed and CE compliant for use in hazardous locations.



Specialized Applications Packages

Most Beck actuators are available with specialized setups for highly corrosive environments or high vibration applications.

Backup Power Supply

The Beck Backup Power Unit (BPU) provides short-duration, backup power for Beck actuators. It is designed to provide power for fail-to-position actuator response or to maintain normal actuator operation for a short period.

The BPU is available for ordinary and hazardous locations. A unit with an additional bank of ultra-capacitors is also available.



Fully charged, the unit will provide backup power for a time dependent upon the power draw required by the actuator motor. Approximate times for the duration of output power (based on wattage) are:

Watts	Seconds	
	Single Bank	Double Bank
34 (1 N•m, 72 RPM motor)	109	218
62	58	116
87 (3 N•m, 72 RPM motor)	44	88
101	37	74
137	26	52

After the unit has been fully discharged, it will take approximately 30 minutes to be completely recharged (~60 minutes for the optional, dual capacitor bank unit).

Remotely Mounted Digital Control Module (DCM)

Most Beck actuators equipped with digital control are available with the option to remotely mount the DCM. The separate enclosure which houses the DCM may be positioned at any convenient distance from the actuator and is available with or without a Handswitch.

This option is ideal for actuators located in extreme environments.



DCM with Feedback Display

Actuators equipped with this feature have a display window built into the DCM compartment cover. This window reveals an LED display showing the position of the actuator based on Feedback loop current (displayed as a percentage of travel within a tenth of a degree).

Also visible through the window are LEDs that light green and red (respectively) at adjustable positions of travel (as a percentage of total travel).



Remote Indication Station with or without Control

An indication station with a stainless steel enclosure is available which could be mounted at the actuator site or at a remote location. An indication station with manual or auto/manual control is also available.



Handswitch Options

Beck Handswitches are available with an auxiliary contact for remote indication. Locking Handswitches are also available.



DPDT Override

Available to provide a control system emergency override relay.

Crank Arm Options

For applications where the standard crank arm will not suffice, extra long or shorter crank arms may be equipped as an option on some Beck actuator models.

SST Hardware

Stainless steel hardware is available for applications in high humidity or particularly wet environments.

Epoxy Paint

For environments where the Beck actuator will come into regular contact with grease, oil, etc., a tough, long-lasting epoxy paint is available for added protection.

Torque / Thrust Sensing

Most option 9 Beck actuators are capable of measuring actuator torque or thrust output. Depending on the model, this may be an extra cost option. This capability provides several features, including:

- A live display of the torque / thrust output.
- The ability to store peak torque / thrust values.
- Ten-segment peak torque / thrust profile for actuator output trending and final control element diagnostics.
- A high torque / thrust alarm that alerts the user when the torque / thrust output exceeds a set value (normally set at 105% of the actuator rating).
- Overtorque / overthrust protection that will shut off power to the motor if the torque / thrust exceeds a specified percentage of the actuator rating (e.g., 150% for Group 11 drives). This value is configurable.

480 Volt Power Option (Group 11)

Typical electric actuators are less efficient than Beck actuators and require 480 Volt, 3-phase power. Due to this requirement, retrofitting a Beck actuator often necessitates new 120 Volt, 1-phase power wires be run to the site. To eliminate this expense and simplify the retrofit, Beck offers an optional 480 Volt power feature for all Group 11 models. This option includes a transformer, power terminations and fusing integral to the actuator body.

Beck Group 11 actuators are also available with 208, 240, 380, 415 & 575 V options.

ACCESSORIES

Mounting Pedestals

Standard and custom retrofit pedestals are available, including designs for a number of common pneumatic actuators such as the Bailey AC and UP series and Hagan cylinders.



Adaptor Plates

Transition from first generation Beck mechanisms and old L & N and Honeywell electric actuators are made easily with pre-drilled, fabricated plates.

Thermal Barriers

Micarta insulation kits are available for all Beck actuators to mitigate heat conduction from the mounting plate.

FACTORY SUPPORT & SERVICES

Product Demonstrations

Beck Factory Sales Engineers can demonstrate virtually any actuator feature by bringing an actuator to your location. To arrange to see a Beck actuator in your plant or office, contact the Beck's Sales Department.

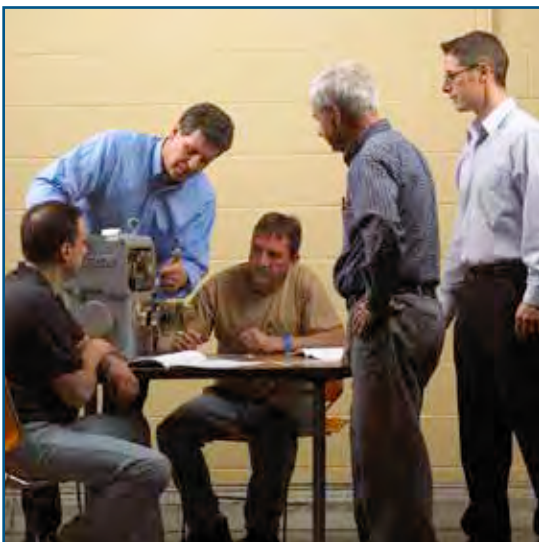

Application Reviews

By sharing your needs with a Beck Factory Sales Engineer, you can take advantage of the best application advice for the type of control you need. This review will yield a better understanding of the versatility of Beck actuators for your installations, as well as complete details on options and accessories to make the process as effective as possible.

Specification Writing

Beck provides specification writing assistance in order to help you specify and order the right actuators for your applications. Beck Factory Sales Engineers will work with you to make it easier for you to obtain the proper equipment and give you confidence that no details are overlooked.

Site Surveys

Beck Factory Sales Engineers are available to discuss your process control requirements. A visit to your location is often the best way to gain a thorough understanding of your needs in order to meet them most accurately and completely. Beck's analysis at the job site can help ensure that specifications are accurate—particularly for complex applications.



Valve Specification Assistance

If you are planning to order valves, Beck Application Engineers will assist you in specifying the right valve for the application. Beck will factory-mount our actuator to the valve and ship it to you fully calibrated and ready for simple drop-in installation.

Spares Planning Service

Beck Spares Planning Service is offered to assist you in stocking key spare parts. We will recommend the minimum number of parts that you should have in stock for the Beck actuators you have in service—providing for fast and efficient replacement on critical units.

Troubleshooting Assistance

Because Beck actuators are constructed with no-burnout motors, sealed electronics and powerful gear trains, they require no periodic maintenance. In the event that a problem does occur, you can refer to detailed instruction manuals, complete with troubleshooting guide, to determine the corrective procedure. This, combined with free on-call phone assistance, will resolve almost any problem and will get you back online quickly.

Factory Repair

Factory repair of drives or subassemblies is available for both normal and emergency service. To assure prompt processing, contact the factory to receive a Returned Material Authorization (RMA) number. If a repair estimation is desired, please send the name and phone number of your contact for service authorization. It is helpful to include a description of the work desired with the shipment or, in the event of a problem, the malfunction being experienced.

Training Services

Beck's technical personnel can provide training services at your plant location. Training topics will include mechanical and electrical installation, diagnostics and troubleshooting, maintenance, and repair.



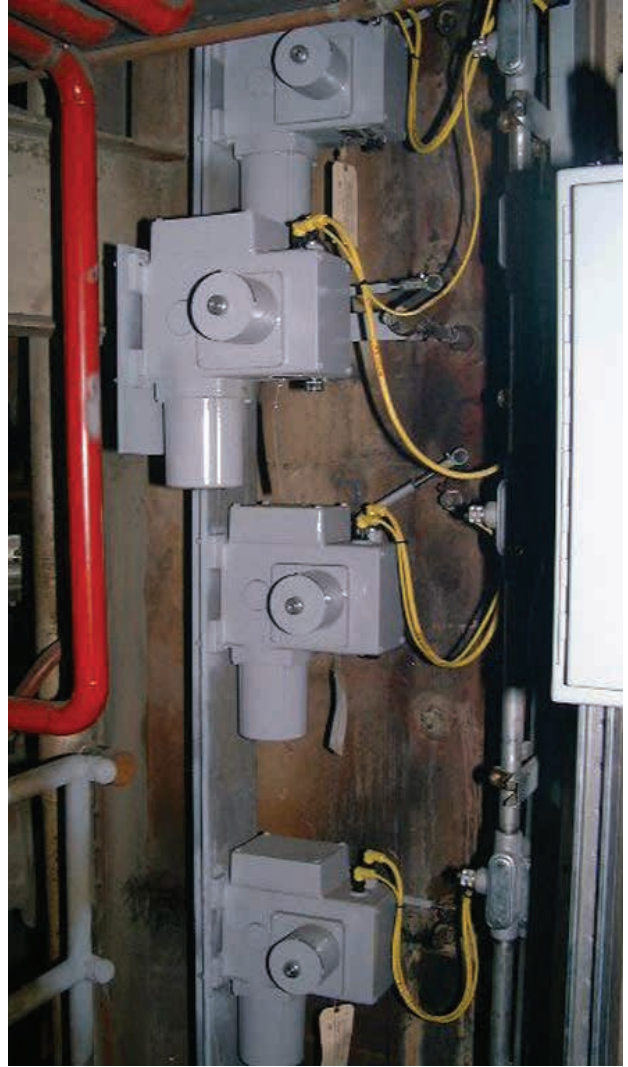





HAROLDBECK.COM

HAROLD BECK & SONS, INC

11 TERRY DRIVE • NEWTOWN, PA 18940 • USA

PHONE: 215-968-4600 • FAX: 215-860-6383

Sales@HaroldBeck.com • HaroldBeck.com



INDUSTRIES SERVED INCLUDE:

ELECTRIC POWER • STEEL & ALUMINUM • WATER & WASTEWATER • PULP & PAPER
CEMENT & LIME • CHEMICAL & PETROCHEMICAL • GLASS • OIL & GAS