

# ROMTEC UTILITIES SCOPE OF SUPPLY AND DESIGN SUBMITTAL

FOR:

# INDIAN SPRINGS STORMWATER (SANTA ROSA, CA)

**DATE:** February 27, 2015

**REVISION:** 2 – For the Record

**ENGINEER CONTACT INFORMATION:**

John Doe  
Company Name  
111 Road Street  
Santa Rosa, CA 95401  
(888) 111-2211  
jdoe@company.com



18240 North Bank Road ~ Roseburg ~ OR ~ 97470  
541.496.9678(ph) / 541.496.0804(fx)  
romtec3@romtecutilities.com



February 27, 2015

To: John Doe,  
Company Name

From: Romtec Utilities Document Control

Re: Documentation for the proposed pump station project identified as

Project Name: Indian Springs Stormwater

Based on Design Criteria dated: 9/16/13

Revision #: 2

Romtec Utilities is pleased to offer this Scope of Supply and Design Submittal for the project listed above. All parties with an interest in this project must carefully read and comprehend the information contained herein.

**1. Introduction**

Includes information about this document and how to use it, typical Romtec Utilities process AND Submittal Approval –Notice to Proceed form.

**2-3. Scope of Supply**

Lists products and services to be supplied by Romtec Utilities and those products and services not supplied by Romtec Utilities.

**4-5. Design Criteria & Project Site**

Includes data supplied to Romtec Utilities by Romtec Utilities' direct customer or customer's representative.

**6. Warranty & Limitations**

Includes warranty details and limitations of Romtec Utilities responsibilities.

**7. Operation & Maintenance Manual**

Includes description of Operation & Maintenance Manual to be supplied by Romtec Utilities.

**8-16. Design Submittal**

Includes detailed drawings, descriptions and specifications of products to be supplied by Romtec Utilities.

Please address questions, comments and requests for changes to this document to:

Romtec Utilities Document Control  
541-496-9678  
romtec3@romtecutilities.com

**Romtec Utilities, Inc.**

18240 North Bank Rd. • Roseburg, OR 97470  
541-496-9678 • www.romtecutilities.com

## INDEX

1. **INTRODUCTION**
  - 1.01 ABOUT THIS DOCUMENT
  - 1.02 HOW TO USE THIS DOCUMENT
  - 1.03 TYPICAL ROMTEC UTILITIES PROCESS
  - 1.04 SUBMITTAL APPROVAL FORM & NOTICE TO PROCEED
2. **SCOPE OF SUPPLY – PRODUCTS & SERVICES**
  - 2.01 ROMTEC UTILITIES SCOPE OF SUPPLY: PRODUCTS
  - 2.02 ROMTEC UTILITIES SCOPE OF SUPPLY: SERVICES
  - 2.03 START-UP, TESTING & TRAINING OUTLINE
  - 2.04 PRE START-UP CHECKLIST
  - 2.05 PRE START-UP SCHEDULING INFORMATION
3. **PRODUCTS & SERVICES NOT SUPPLIED BY ROMTEC UTILITIES**
  - 3.01 PRODUCTS & MATERIALS NOT SUPPLIED BY ROMTEC UTILITIES
  - 3.02 SERVICES NOT SUPPLIED BY ROMTEC UTILITIES
4. **DESIGN CRITERIA**
  - 4.01 INTRODUCTION TO DESIGN CRITERIA
  - 4.02 LIFT STATION DESIGN CRITERIA FORM
5. **PROJECT SITE**
  - 5.01 SITE SPECIFIC CONDUIT & WIRE LAYOUT
6. **WARRANTY & LIMITATIONS ON WARRANTY**
  - 6.01 ROMTEC UTILITIES LIMITED WARRANTY
  - 6.02 LIMITATIONS OF ROMTEC UTILITIES' RESPONSIBILITIES
7. **OPERATION & MAINTENANCE (O&M) MANUAL**
8. **WET WELL & RELATED EQUIPMENT**
  - 8.01 WET WELL COMPONENT DRAWING(S)
  - 8.02 WET WELL PRODUCTION DRAWING(S)
  - 8.03 WET WELL HATCH DRAWING
  - 8.04 WET WELL WEIGHTS & LIFTING DEVICES
  - 8.05 WET WELL TESTING FOR WATER INGRESS OR EGRESS
  - 8.06 WET WELL RELATED DATA SHEETS

## INDEX

- 8.06.1 BARREL GASKETS
- 8.06.2 CONSEAL
- 8.06.3 TAPECOAT
- 8.06.4 KOR-N-SEALS
- 8.06.5 SWING CHECK VALVE
- 8.06.6 COUPLING ROMAC RFCA
- 8.06.7 ROMAGRIP ACCESSORY PACK

### 9. **PUMPS**

- 9.01 PUMP SPECIFICATIONS
- 9.02 PUMP DIMENSIONAL DRAWINGS
- 9.03 PUMP PERFORMANCE CURVES
- 9.04 PUMP EXTENDED STORAGE
- 9.05 PUMP RELATED DATA SHEETS
  - 9.05.1 HUBBELL SUPPORT GRIPS
  - 9.05.2 PUMP LIFTING RING

### 10. **LEVEL SENSORS**

- 10.01 PRIMARY LEVEL SENSOR DATA SHEETS
- 10.02 SECONDARY LEVEL SENSOR DATA SHEETS

### 11. **ELECTRICAL INTERCONNECTIONS**

- 11.01 TYPICAL FIELD WIRING PLAN
- 11.02 ELECTRICAL INSTALLATION RECOMMENDATIONS
- 11.03 PUMP CABLE INSPECTION AND INSTALLATION RECOMMENDATIONS

### 12. **CONTROL PANEL & COMMUNICATIONS**

- 12.01 STANDARD TEMPERATURE SPECIFICATIONS
- 12.02 POWER QUALITY DISCLAIMER
- 12.03 ELECTRICAL SYSTEM DESIGN VOLTAGE
- 12.04 SPECIFICATIONS – CONTROL PANEL SCOPE OF SUPPLY
- 12.05 ONE-LINE DRAWING

## INDEX

- 13. **PUMP ELECTRICAL ENCLOSURE**
  - 13.01 PUMP ELECTRICAL ENCLOSURE DRAWINGS
- 14. **PRE-INSTALLATION**
  - 14.01 PRE-INSTALLATION INFORMATION
  - 14.02 PRE-INSTALLATION CHECKLIST
  - 14.03 INSTALLATION DATA SHEETS
- 15. **FIELD START-UP REPORT**
  - 15.01 FIELD START-UP REPORT
- 16. **AUTODESK DESIGN REVIEW**
  - 16.01 AUTODESK DESIGN REVIEW DOWNLOAD PROCEDURE

## **1. INTRODUCTION**

This section contains the necessary information and procedures for the understanding and use of this document by the client and other parties of interest.

This section is structured as follows:

- 1.01 ABOUT THIS DOCUMENT
- 1.02 HOW TO USE THIS DOCUMENT
- 1.03 TYPICAL ROMTEC UTILITIES PROCESS
- 1.04 SUBMITTAL APPROVAL/NOTICE TO PROCEED FORM

## 1.01

## ABOUT THIS DOCUMENT

### 1. Document identification

This Scope of Supply and Design Submittal provided by Romtec Utilities, Inc., herein referred to as Romtec Utilities contains the information for the project listed below:

Name (herein referred to as "the project"): Indian Springs Stormwater

Location (herein referred to as "the site"): Santa Rosa, California

Document Date: 2/27/15

Revision #: 2

### 2. The Romtec Utilities Scope of Supply & Design Submittal is defined by Romtec Utilities as follows:

#### a. A Complete document

This document is Romtec Utilities' complete Scope of Supply and Design Submittal for the project referenced above. There is no other document that contains this information. This document supersedes all other documents, written correspondence and verbal communication as to Romtec Utilities scope of supply, products and services.

#### b. Supplied to customer only

Romtec Utilities supplies this document exclusively to the direct customer (the entity signing Romtec Utilities' purchase order), herein referred to as the customer, and not to any other party associated with this specific project. Any other party reviewing any part of this document is informed that the information within it is Romtec Utilities' communication with the customer and no other party.

#### c. Based on customer-supplied design criteria

Romtec Utilities has designed the pump station described herein to meet the specific design criteria provided to Romtec Utilities by the customer and/or the customer's representative on the Lift Station Design Form (Section 4). Romtec Utilities' supply of products and services is related exclusively to these design criteria.

#### d. Entire supply and design for Customer only

Romtec Utilities' entire supply and design, as described in the Scope of Supply and Design Submittal, are for the customer only and no one else. Romtec Utilities will not provide any other products and/or services related to the project to any other party.

**1.01****ABOUT THIS DOCUMENT****e. Limited to this supply and design**

Romtec Utilities agrees only to the supply and design described in this Scope of Supply and Design Submittal. Romtec Utilities expressly states that this document does not meet, and Romtec Utilities does not agree to meet any agency standard, any other specification or any other document and/or statement describing the project.

**f. Approval is acceptance of this supply and design**

By approving this document, the customer accepts the products and services identified herein to be supplied by Romtec Utilities.

**g. Change orders**

The customer agrees that, following approval of this document, there can be no modification to the products and services described herein without a written change order issued to Romtec Utilities by the customer and/or the customer's representative on the standard Romtec Utilities Change Order Form. The customer acknowledges that change orders will incur additional charges to the customer and may cause delays in Romtec Utilities' delivery of the products and services described herein as well as any products and services required by the change orders.

**3. This Romtec Utilities Scope of Supply & Design Submittal supersedes all prior design and bid documents related to the project as follows:****a. This document negates other pump station documents/statements**

Romtec Utilities recognizes that projects often begin with other designs and bid documents, however this document supersedes and makes null and void any other document or statement from any party, including Romtec Utilities' own prior documents and/or statements, as related to the pump station described in this Scope of Supply and Design Submittal.

**b. This document does not represent other documents/statements**

This document does not represent any specific standards, bid documents, design drawings or any other document and/or statements by any party other than Romtec Utilities.



## 1.01

## ABOUT THIS DOCUMENT

**4. This Scope of Supply and Design Submittal states that the following are not Romtec Utilities' responsibility:**

**a. Suitability of the pump station**

It is not Romtec Utilities' responsibility to determine the suitability of the pump station to the project's site plan, electrical plan, influent line and force main profiles and other documents.

**b. Document analysis is Customer's responsibility**

This Scope of Supply and Design Submittal is limited to the pump station; however this document must be considered in its relationship with the overall project and site. It must be analyzed along with the project's site plan, electrical plan, influent line and force main profiles and other documents. Romtec Utilities does not provide this analysis, which is the responsibility of the customer and/or the customer's representative.

**c. Requested layouts are suggestion only**

At the Customer's request, Romtec Utilities will provide suggested layouts of the products to be supplied by Romtec Utilities on the Approved Site Plan provided by the customer. The customer can choose to accept or reject any suggested layouts.

**d. No claim or guarantee of site conformance or suitability**

Romtec Utilities makes no claim and provides no guarantee that any of the products to be supplied by Romtec Utilities will fit on project's site or within any building associated with the project.

## 1.02 HOW TO USE THIS DOCUMENT

### 1. Be sure that the Document Date and Revision # are current

If unsure, contact: **Romtec Utilities Document Control**  
18240 North Bank Rd., Roseburg, OR 97470  
541-496-9678 (phone); 541-496-0804 (fax)  
romtec3@romtecutilities.com

### 2. Carefully review all sections of this document

If unsure of any information, contact Romtec Utilities Document Control immediately.

### 3. How to make comments and request changes

Comments and/or requests for changes to this document must be submitted, **in a written document, either MS Word or MS Excel**, to Romtec Utilities Document Control.

Please supply a list of your comments and change requests along with a copy of any marked up drawing, edited specification or any other part of the document to which you are commenting or requesting a change. All redline comments must be numbered on the drawing or specification and have a corresponding written explanation on the written document. Romtec Utilities will send the reviewing authority further instructions and a blank comment log in MS Excel format that can be filled out and sent back after reviewing the SSDS. If the reviewer would rather use their own format, it must have the same information provided as the Romtec Utilities blank comment log.

Romtec Utilities will promptly review your comments and/or change requests, and will contact you to ensure complete understanding. Revisions to the Scope of Supply and Design Submittal for this project are made at the discretion of Romtec Utilities.

### 4. How to approve the design

The Submittal Approval Form is included with this document. To approve the design, you must check, initial and sign where requested. Email, fax or mail the completed form to Romtec Utilities Document Control.

## 1.03 TYPICAL ROMTEC UTILITIES PROCESS

**Below the typical steps in the process to design, price, approve, produce, deliver, install and start-up a Romtec Utilities pump station are listed:**

1. Customer (or customer's representative) sends pump station design criteria to Romtec Utilities.
2. Romtec Utilities produces preliminary pump station design and quotation, sends to Customer.
3. Customer sends Purchase Order to Romtec Utilities.
4. Romtec Utilities produces Scope of Supply and Design Submittal, sends to Customer.
5. Customer reviews Scope of Supply and Design Submittal, sends written comments to Romtec Utilities.
6. Based on Customer comments, Romtec Utilities revises Scope of Supply and Design Submittal and, if necessary, the pump station quotation; sends revised documents to customer.
7. Customer distributes revised Scope of Supply and Design Submittal to all project stakeholders, gathers comments from Stakeholders, sends written comments to Romtec Utilities.
8. Based on stakeholder comments, Romtec Utilities revises Scope of Supply and Design Submittal and, if necessary, the pump station quotation; sends revised documents to customer.
9. Customer and stakeholders send formal approval of Scope of Supply and Design Submittal to Romtec Utilities.
10. Customer sends Notice to Proceed with delivery date to Romtec Utilities.
11. Romtec Utilities begins pump station manufacturing and sends projected delivery date to customer.
12. Customer's contractor prepares project site for installation of pump station.
13. Romtec Utilities delivers pump station to project site.
14. Customer's contractor installs underground portion of pump station.
15. Customer's electrical contractor performs electrical construction/installation.
16. Romtec Utilities performs pump station start-up and testing.

### 1.03 TYPICAL ROMTEC UTILITIES PROCESS

17. Warranty period commences.
18. Romtec Utilities performs operation and maintenance (O&M) training and delivers O&M manuals to the customer.

## 1.04 SUBMITTAL APPROVAL FORM & NOTICE TO PROCEED

I, \_\_\_\_\_, representing \_\_\_\_\_, have reviewed the Romtec Utilities' Scope of Supply and Design Submittal for the project named \_\_\_\_\_, dated \_\_\_\_\_, revision # \_\_\_\_\_, purchase order # \_\_\_\_\_.

### 1. INTRODUCTION

\_\_\_\_\_ I have read the introduction outlining how this submittal will be used, and I agree that these lists are complete and correct.

\_\_\_\_\_ I request the following changes: \_\_\_\_\_

### 2. SCOPE OF SUPPLY – PRODUCTS & SERVICES

\_\_\_\_\_ I have read the detailed lists of products and services to be supplied By Romtec Utilities, and I agree that these lists are complete and correct.

\_\_\_\_\_ I request the following changes: \_\_\_\_\_

### 3. PRODUCTS & SERVICES NOT SUPPLIED BY ROMTEC UTILITIES

\_\_\_\_\_ I have read the detailed lists of products and services to be not supplied By Romtec Utilities, and I agree that these lists are complete and correct.

\_\_\_\_\_ I request the following changes: \_\_\_\_\_

### 4. DESIGN CRITERIA

\_\_\_\_\_ I have confirmed that the data listed on the Lift Station Design Form are accurate.

### 5. PROJECT SITE

\_\_\_\_\_ If site drawings (by others) are included in this document; I have confirmed they are accurate.

### 6. WARRANTY & LIMITATIONS

\_\_\_\_\_ I have read the Romtec Utilities, Inc. Limited Warranty & Limitations. I agree with its terms conditions and limitations.

### 7. OPERATION & MAINTENANCE (O&M) MANUAL

\_\_\_\_\_ I have reviewed the operation & maintenance section. I approve the documents as submitted.

\_\_\_\_\_ I request the following changes: \_\_\_\_\_

### 8. WET WELL & RELATED EQUIPMENT

\_\_\_\_\_ I have reviewed the wet well documents. I approve the documents as submitted.

\_\_\_\_\_ I request the following changes: \_\_\_\_\_

## 1.04 SUBMITTAL APPROVAL FORM & NOTICE TO PROCEED

### 9. PUMPS

\_\_\_\_\_ I have reviewed the documents for the pumps. I approve the documents as submitted.

\_\_\_\_\_ I request the following changes: \_\_\_\_\_

### 10. LIQUID LEVEL SENSORS

\_\_\_\_\_ I have reviewed the documents for the liquid level sensors. I approve the documents as submitted.

### 11. ELECTRICAL INTERCONNECTIONS

\_\_\_\_\_ If site electrical drawings (by others) are included in this document; I have confirmed they are accurate.

### 12. CONTROL PANEL & COMMUNICATIONS

\_\_\_\_\_ I have reviewed the documents for the control panel/electrical and communications system. I approve the documents as submitted.

\_\_\_\_\_ I request the following changes: \_\_\_\_\_

### 13. PUMP ELECTRICAL ENCLOSURE

\_\_\_\_\_ I have reviewed the documents for the pump electrical connection enclosure/panel. I approve the documents as submitted.

\_\_\_\_\_ I request the following changes: \_\_\_\_\_

### 14. PRE-INSTALLATION

\_\_\_\_\_ I have reviewed the document describing the pre-installation requirements. I approve the documents as submitted.

\_\_\_\_\_ I request the following changes: \_\_\_\_\_

### 15. FIELD START-UP REPORT

\_\_\_\_\_ I have reviewed the document describing the field start-up report requirements. I approve the documents as submitted.

\_\_\_\_\_ I request the following changes: \_\_\_\_\_

## 1.04 SUBMITTAL APPROVAL FORM & NOTICE TO PROCEED

Upon receipt of your notice to proceed, Romtec Utilities will produce the pump station and deliver it to the project site on or after the date you specify.

Please fill in the form below.

- Yes, I want Romtec Utilities to produce the specified pump station and deliver it to the project site to be installed on \_\_\_\_\_.  
(delivery date)
- No, I don't want Romtec Utilities to produce and deliver the pump station at this time. I will send a separate written notice to proceed at a later date.

---

Signature

Date

By signing the Submittal Approval & Notice to Proceed, I approve the products and services as specified in the Romtec Utilities Scope of Supply and Design Submittal for this project. I understand that any change(s) I have requested may change other Romtec Utilities documents, including but not limited to the pump station quote, the scope or supply and design submittal and the O&M manual. I understand that such changes may cause delays to the project.

Please return the form to: Documentation Manager  
Romtec Utilities, Inc.  
18240 North Bank Rd.  
Roseburg, OR 97470  
Fax: 541-496-0804  
Email: romtec3@romtecutilities.com

**END  
OF  
SECTION**



## 2. SCOPE OF SUPPLY – PRODUCTS & SERVICES

This section outlines what products and services are provided by Romtec Utilities for this design. In addition, this section includes the Pre Start-Up Preparation Checklist to be filled out by the owner/contractor prior to the scheduled start-up and scheduling information.

This section is structured as follows:

- 2.01 ROMTEC UTILITIES SCOPE OF SUPPLY: PRODUCTS
- 2.02 ROMTEC UTILITIES SCOPE OF SUPPLY: SERVICES
- 2.03 START-UP, TESTING & TRAINING OUTLINE
- 2.04 PRE START-UP CHECKLIST
- 2.05 PRE START-UP SCHEDULING INFORMATION

Send the completed Start-Up Preparation Checklist to:

Romtec Utilities Document Control  
18240 North Bank Rd., Roseburg, OR 97470  
Phone: 541-496-9678; Fax: 541-496-0804  
Romtec8@romtecutilities.com

### **IMPORTANT!**

Various products and services NOT supplied by Romtec Utilities are listed in the Warranty & Limitations section of this Scope of Supply and Design Submittal.

## 2.01 ROMTEC UTILITIES SCOPE OF SUPPLY: PRODUCTS

### COMPLETE PUMP STATION INCLUDES:

#### WET WELL & RELATED EQUIPMENT

##### QTY ITEM

1	BASE ASSEMBLY
1	BASE - WW - 10ft - RU FLAT BASE - 12ft X 14ft
1	PUMP SHELF - 10ft X 3.125in
2	DISCHARGE ELBOW - 12in - EBARA - LL300Y
2	ANCHOR KIT - DISCHARGE ELBOW (1 3-16in BOLTS)
2	COUPLING - ROMAC - RFCA - 12in FBEC
1	BARREL - 10ft DIA X 1ft H
1	BARREL - 10ft DIA X 2ft H
1	BARREL - 10ft DIA X 6ft H
1	TOP SLAB ASSEMBLY
1	HATCH - WW - 10ft PED - DUPLEX - 55788 - 54 x 88
1	TOP SLAB - WW - 10ft PED - DUPLEX
2	UGBB - 3in - EBARA
2	BOLT & NUT KIT - UPPER GUIDE BAR BRACKET - 3-8in
2	CABLE HANGER ASSEMBLY
1	4 INCH PVC VENT
1	VENT - MUSHROOM CAP
1	ADAPTOR - 4in SCH80 - MALE THD X SLIP
1	4in PVC - SCH 80 X 24in
1	4 INCH PVC - SCH 80 X 48in
1	ELBOW - PVC - 4in SCH 80 - 90 DEGREE - SLIP X SLIP
2	DISCHARGE PIPE SUPPORT - WALL BRACKET SET
4	DISCHARGE CLAMP BOLT - 1-2 X 1 SS BOLT, WASHER, FIBER LOCK NUT
2	DISCHARGE PIPE SUPPORT - BOLT KIT
1	SHIPPING CRATE
4	BARREL GASKET
1	STILLING WELL SUPPORT BRACKET - STAINLESS
4	LIFTING CLUTCH - 8 TON
2	CORD GRIP - .46 - .56 SS
2	LINK - .62in - OBLONG WELDED CORROSION RES - EBARA PUMPS
2	BOW SHACKLE - 1-2in - SS W-SCREW PIN
4	CHAIN - S5 5-16in 316SS (2 @ 2FT)
2	CORD GRIP - 1.000in - 1.240 DIA SS
2	LIFTING SLING - .125in SS CABLE (2 @ 12 FT)
1	KOR-N-SEAL - 36in X 30in PIPE
1	KOR-N-SEAL - 8in CORE -1.70 THRU 4.80 PIPE
2	KOR-N-SEAL - 16in CORE - 12in PIPE
6	GASKET - FLANGE - 12in X 1/8in
1	6" PVC PIPE - PERFORATED X 108in

## 2.01 ROMTEC UTILITIES SCOPE OF SUPPLY: PRODUCTS

- 163 TAPECOAT - 6in X .65mils X LFT
- 174 SEALANT - 1in X 1in X 14.5ft CS-202
  - 1 NEVER SIEZE - TUBE
  - 2 FLOAT - NOLTA - MS1 - 20m
  - 1 PRESSURE TRANSDUCER - 4-20 ma - 5 PSI - CL1 DIV1 - 50ft CABLE
  - 1 BRACKET - TRANSDUCER - HANGING
  - 1 DISCHARGE PIPE BRACKET - 16in
  - 2 PUMP - EBARA - 300DLFU630 - 40HP
- 40 PIPE - 304SS - 3in SCH10 (4@ 10 FT)
  - 2 VALVE - SWING CHECK - 12in - SG BUSTER
  - 2 SLEEVE - 12 IN - STAR - SOLID DI SHORT
  - 4 ROMAGRIP ACCESSORY PACK - 12in DI MJ
  - 2 SPOOL - FLG X PE - 12in X 30in - DI
  - 2 SPOOL - FLG X PE - 12in X 72in - DI
  - 2 ELBOW - DI - 12in - 90 DEG - FLG X FLG

### CONTROL PANEL/ELECTRICAL & COMMUNICATION

#### QTY ITEM

- 1 PC3000 Duplex Pump Controller w/ 2-Float Back-up System, 480V/3-PHASE - NEMA 4 Enclosure

**2.02****ROMTEC UTILITIES SCOPE OF SUPPLY:  
SERVICES****1. Administrative & design services**

- a. Receive pump station design criteria from customer or customer's representative.
- b. Design pump station to meet the design criteria and perform as specified.
- c. Produce all drawings and other documents included in this Scope of Supply and Design Submittal.
- d. Only if ordered by customer or customer's representative, provide optional sealing of drawings, calculations and/or the entire Design Submittal at additional cost to customer.
- e. Receive submittal approval from customer or customer's representative
- f. Receive purchase order and notice to proceed from customer's installation contractor.

**2. Production services**

- a. Produce the complete pump station as specified in Scope of Supply-Products.

**3. Delivery services**

- a. Deliver pump station to project site on date(s) specified by customer or customer's representative.
- b. Provide information on weights of parts and lifting devices.

**4. Pre-installation & installation advisory services**

- a. Provide advisory services to our customer or customer's representative and/or their contractor(s) and others who will install/construct this pump station on the site. One day is provided.
- b. Romtec Utilities personnel at the project site during installation of the pump station's underground components are there only in an advisory capacity. Romtec Utilities does not perform work during this phase of the project, unless such work is specified in the SSDS.

**5. Electrical advisory services**

- a. Provide advisory services through customer or customer's representative to the licensed electrical contractor installing electrical service to the pump station.

## 2.02

## ROMTEC UTILITIES SCOPE OF SUPPLY: SERVICES

### 6. Start-up services

- a. Direct all pump station start-up activities at the project site on the designated start-up day. One day is provided.

### 7. Testing & training services

- a. Perform all pump station tests specified in Field Start-Up Report for the project, report test results to the Customer or Customer's representative, deliver O&M Manuals and train any and all owners.
- b. Training is provided contiguous to the start-up date. If the testing and training is not scheduled and/or completed the day following start-up, there will be additional charges for Romtec Utilities to return and complete the testing and training services.
- c. It is required that the main contact to be in charge of operation and maintenance of the lift station, through the duration of the warranty period, be identified and present at the training. This person is responsible for troubleshooting, with the help of Romtec Utilities over the phone, in the event of a warranty issue throughout the one year warranty period beginning the day Start up Training is completed. All other personnel relevant to the maintenance and operation of the lift station are required to be present for the duration of startup training.

**Start-up, testing & training outline**

1. Understanding the Complete System (Wet Well-Bottom up)
  - a. Pumps (with assistance from pump manufacturer's representative)
  - b. Guide Rails
  - c. Elbows
  - d. Level devices
  - e. Hatches
  - f. Level sensors
  
2. Control panel (Overview/Power Up)
  - a. Overview (Front Panel)
  - b. Procedure of operating panel
  - c. Overview (inside panel)
  - d. Power up Procedure
  - e. Back-up System Operations
  - f. Primary Level Operation/Lead-lag, Alternations, Starts/Stops.
  - g. Controller Operation
  
3. System Protection Methods/Devices
  - a. Seal Thermal-Moisture Seals
  - b. Phase Monitor
    - i. Surge Suppression
  
4. Alarms
  - a. Critical Alarms
  - b. Non-critical Alarms

## 2.03

## START-UP, TESTING & TRAINING OUTLINE

5. Trouble Shooting
  - a. Hands On
  - b. Who to call first

***Note: Please see the "Pre Start-up Checklist" following this page and the "Field Start-Up" section of the SSDS for a more detailed example of what is covered on the day of start-up.***

## Pre Start-Up Checklist

### OVERVIEW

This form and associated photos must be completed and returned before Romtec Utilities will schedule or confirm any Start-up Testing and Training dates. Send the completed checklist to [romtec8@romtecutilities.com](mailto:romtec8@romtecutilities.com) or fax to 541-496-0804.

This document is a checklist. It ensures that all necessary components have been installed and that your lift station is prepared and ready for start-up. We have outlined below the tasks that need to be completed before start-up and training can occur in the following sections:

1. Review of previously completed underground construction
2. Review of electrical construction connecting to the wet well
3. Communication equipment
4. Water availability
5. Wet Well
6. Required photos
7. Personnel required for start-up testing
8. Personnel required for start-up training

All activities and requirements stated in this document have been approved in the Scope of Supply and Design Submittal.

Please follow this checklist to ensure that all appropriate actions have been taken in preparation for start-up and personnel training for your lift station.

### **ATTENTION!**

**DO NOT LOWER THE PUMPS INTO THE WET WELL. A Romtec Utilities start-up advisor will lower the pumps into the wet well at start-up, in accordance with the pump warranty. If you lower the pumps on your own you risk voiding the warranty.**



**1. PREVIOUSLY COMPLETED UNDERGROUND CONSTRUCTION REVIEW**

The following wet well and valve vault components must be installed and approved.

	<b>YES</b>	<b>NO</b>
<b>i. Discharge Pipes</b>		
1. Are connected to elbows?	<input type="checkbox"/>	<input type="checkbox"/>
2. Are plumb and connected to discharge pipe brackets?	<input type="checkbox"/>	<input type="checkbox"/>
3. Are connected to valve vault?	<input type="checkbox"/>	<input type="checkbox"/>
<b>ii. Valve Vault</b>		
1. Is connected to force main?	<input type="checkbox"/>	<input type="checkbox"/>
2. Upstream valves are open for wet well discharge?	<input type="checkbox"/>	<input type="checkbox"/>
<b>iii. Guide Bars</b>		
1. All stainless steel guide bars installed?	<input type="checkbox"/>	<input type="checkbox"/>
2. Upper guide bar brackets are installed and tight?	<input type="checkbox"/>	<input type="checkbox"/>
3. Intermediate guide bar brackets (if equipped) are installed?	<input type="checkbox"/>	<input type="checkbox"/>

**2. REVIEW OF ELECTRICAL CONSTRUCTION CONNECTING TO THE WET WELL**

*Note: High voltage is in use. Only licensed and qualified personnel should perform electrical services in preparation for, and during start-up.*

	<b>YES</b>	<b>NO</b>
<b>i. Have the conduits been installed between the wet well and the main control panel (At least one (1) for each pump cable and at least one (1) for the level control device)</b>	<input type="checkbox"/>	<input type="checkbox"/>

*Note: Romtec Utilities does not core holes into the wet well for electrical conduit ports or conduit runs. The cored holes in the wet well are the responsibility of the contractor and electrician. Final size, orientation, height, and number are best determined after installation of the wet well and other electrical components.*

**CAUTION!**

**All cored holes into the wet well shall be made 8 in. above or 3 in. below any barrel joints in such a manner as not to impact the integrity of the barrel joint and seal.**

- |  | YES                      | NO                       |
|--|--------------------------|--------------------------|
| ii. Have the level control wires been pulled between the pump control panel and the wet well?  | <input type="checkbox"/> | <input type="checkbox"/> |
| iii. Have the level control wires been landed on the appropriate terminals inside the control panel?   | <input type="checkbox"/> | <input type="checkbox"/> |
| <i>Note: The pump power cables will be pulled through the conduit at the time of start-up.</i>   |                          |                          |
| iv. Have the "meter base" and main disconnect been installed and inspected?  | <input type="checkbox"/> | <input type="checkbox"/> |
| v. Have the panel power wires been installed between the main disconnect, automatic transfer switch (if present) and the pump control panel? | <input type="checkbox"/> | <input type="checkbox"/> |
| vi. Has the power company energized the meter?   | <input type="checkbox"/> | <input type="checkbox"/> |
| <i>Note: Permanent utility power to the job site is required in order to perform start-up, testing, and training.</i>                        |                          |                          |
| vii. Is all necessary field wiring complete?   | <input type="checkbox"/> | <input type="checkbox"/> |
| <i>Note: Romtec Utilities reserves the right to charge for our time required to complete wiring.</i>   |                          |                          |

**3. COMMUNICATION EQUIPMENT**

- |  | YES                      | NO                       |
|--|--------------------------|--------------------------|
| i. Has all required communication equipment (radio, phone, cellular) been installed and confirmed to be operational? | <input type="checkbox"/> | <input type="checkbox"/> |

**4. WATER AVAILABILITY**

- |  |                          |                          |
|--|--------------------------|--------------------------|
| i. Is enough water available to fill the wet well 1-½ times? | <input type="checkbox"/> | <input type="checkbox"/> |
|--|--------------------------|--------------------------|

**5. WET WELL**

- i. Is the wet well clean and free of any debris?
- ii. Have the incoming sewer line(s) and upstream man holes been flushed of all debris?
- iii. Do you have permission from the appropriate parties to pump water out of the pump station into the treatment plant?

**IMPORTANT!**

**All debris must be flushed from all inlet lines and man holes prior to starting the system.**

**6. REQUIRED PHOTOS**

Have the following required photos been taken and prepared to deliver with the checklist?

- |  | <b>YES</b>               | <b>NO</b>                |
|--|--------------------------|--------------------------|
| i. Photo of the inside of the control panel (specifically the terminal blocks at the base of the panel). | <input type="checkbox"/> | <input type="checkbox"/> |
| ii. Photo of the control and disconnect panel from approx. 5 ft. away.                                   | <input type="checkbox"/> | <input type="checkbox"/> |
| iii. Photo of the inside of the wet well.  | <input type="checkbox"/> | <input type="checkbox"/> |
| iv. Photo of the inside of the valve vault. (if applicable)  | <input type="checkbox"/> | <input type="checkbox"/> |
| v. Photo of the inside of the meter vault. (if applicable)   | <input type="checkbox"/> | <input type="checkbox"/> |

**7. PERSONNEL REQUIRED FOR START-UP**

*Note: It is the contractor's responsibility to invite and schedule all appropriate parties.*

**Safety Manager:**

Name: \_\_\_\_\_  
Company: \_\_\_\_\_  
Phone: \_\_\_\_\_

**Site Engineer's Representative:**

Name: \_\_\_\_\_  
Company: \_\_\_\_\_  
Phone: \_\_\_\_\_

**Owner's Representative:**

Name: \_\_\_\_\_  
Company: \_\_\_\_\_  
Phone: \_\_\_\_\_

**Electrical Inspector(s):**

Name: \_\_\_\_\_  
Company: \_\_\_\_\_  
Phone: \_\_\_\_\_

**Site Electrician:**

Name: \_\_\_\_\_  
Company: \_\_\_\_\_  
Phone: \_\_\_\_\_

8. **PERSONNEL REQUIRED FOR START-UP TRAINING**

Have the appropriate personnel been informed of the date in which start up training will occur?

YES NO

**Main Contact to be in charge of operation and maintenance of the lift station through the duration of the warranty period:**

Name: \_\_\_\_\_

Company: \_\_\_\_\_

Phone: \_\_\_\_\_

*Note: This person is responsible for troubleshooting with the help of Romtec Utilities over the phone in the event of a warranty issue throughout the one year warranty period beginning the day Start up Training is completed.*

*Special Note: All other personnel relevant to the maintenance operation of the lift station are required to be present for the duration of startup training.*

**IMPORTANT!**

**This form must be completed before Romtec Utilities can schedule travel for your start-up advisor. Your project start-up date can be set with Romtec Utilities at any time. By completing the start-up preparation documents you are acknowledging the following:**

- a. Romtec Utilities has provided its customer with two contiguous days for start-up, testing, and training. If you say you are ready for Romtec Utilities to come to the site and perform these services, when in fact you are not ready, Romtec Utilities will charge its customer for another trip and the time (two days) on the job site to perform these services.
- b. The Romtec Utilities system warranty is not provided to its customer and/or the owner unless, and until, the Romtec Utilities system start-up, testing, and training have been completed.
- c. By signing this document you agree to reimburse Romtec Utilities for any costs incurred, whether by Romtec Utilities directly or through a related vendor, due to on-site delays caused by inaccurate representations herein. Typical costs attributed to delays include labor, travel and lodging. However, this list is not meant to be exclusive, and other costs may apply.

**Please send this Checklist and the required photos back to Romtec Utilities two (2) weeks before the scheduled start-up and training dates.**

**PROPOSED START-UP & TRAINING DATES:** \_\_\_\_\_

\_\_\_\_\_  
**AUTHORIZED SIGNATURE**

\_\_\_\_\_  
**DATE**

**2.05****PRE START-UP SCHEDULING INFORMATION****Scheduling for Start-Up and Training:**

1. Lead time to schedule start-up.
  - a. Romtec Utilities and all associated technical personnel require four (4) weeks advance notice to schedule a start-up date. The start-up checklist attached must also be completed two weeks prior to the requested start-up date.
2. Duration of start-up and training.
  - a. Start-up begins at **8 am** and will require one (1) full day.
  - b. Training begins the following day at **8 am** and the advisor will be available all day.
  - c. These days **must be contiguous weekdays**. Romtec Utilities does not schedule start-ups over Saturdays or Sundays.
  - d. Please see attached document outlining events performed at start-up and training.

***Note:*** *These timelines are stated in the approved Romtec Utilities Scope of Supply and Design Submittal.*

3. Scheduling pump and generator services.
  - a. If Romtec Utilities is providing services from a generator or pump supplier to the customer during start-up and training, these vendors will only be available the same days that Romtec Utilities' personnel are on-site.

***Note:*** *These timelines are stated in the approved Romtec Utilities Scope of Supply and Design Submittal.*

**ATTENTION!****PROPER EQUIPMENT MUST BE ON-SITE THE DAY OF START-UP**

**You must provide equipment to safely lower the pumps into the wet well. Romtec Utilities will not proceed with start-up if there is not equipment to lower the pumps.**

**END  
OF  
SECTION**



### **3. PRODUCTS & SERVICES NOT SUPPLIED BY ROMTEC UTILITIES**

This section outlines what products and services are not provided by Romtec Utilities for this design.

This section is structured as follows:

3.01 PRODUCTS & MATERIALS NOT SUPPLIED BY ROMTEC UTILITIES

3.02 SERVICES NOT SUPPLIED BY ROMTEC UTILITIES

### 3.01

## PRODUCTS & MATERIALS NOT SUPPLIED BY ROMTEC UTILITIES

Each Romtec Utilities pump station is designed and supplied for the specific pumping requirement, as determined by the design criteria provided to Romtec Utilities by the customer or the customer's representative.

The specific products and materials to be supplied by Romtec Utilities are unique to this pump station and are listed in the Scope of Supply-Products list. Any component not on the list will not be supplied by Romtec Utilities.

Unless otherwise specified, products and materials NOT supplied by Romtec Utilities include:

- 1. Any item not listed in the Scope of Supply-Products**
  - a. Any fasteners not associated with the pre-assembled systems or components not listed in the Scope of Supply-Products list are NOT supplied.
- 2. Site drawings**
  - a. Any site drawing included in this Scope of Supply and Design Submittal has been supplied by others.
- 3. Construction equipment, materials and labor for:**
  - a. Unloading trucks, traffic control, site safety
  - b. Securing materials delivered to project site: dunnage, fencing, storage
  - c. Excavation, shoring, dewatering, sub-base rock, backfill material
  - d. Installation of supplied pump station systems and components
  - e. Piping to and from pump station
  - f. Piping between pump station systems (i.e. between wet well and valve vault)
  - g. Electrical conduit and wiring (except wires attached to supplied components)
  - h. Concrete poured in place, crushed rock, asphalt paving
  - i. Site lighting, signage, fencing, bollards
  - j. Site drainage control

## 3.02 SERVICES NOT SUPPLIED BY ROMTEC UTILITIES

The services to be supplied by Romtec Utilities are unique to this pump station and are listed in the Scope of Supply-Services list. Any service not on the list will not be supplied by Romtec Utilities.

**Unless otherwise specified, services NOT supplied by Romtec Utilities include:**

- 1. Any item not listed in the Scope of Supply-Services**
- 2. Sealing of the Scope of Supply and Design Submittal, including drawings contained herein**
  - a. If required, sealing of this document and/or supply of sealed plans and/or calculations are available from Romtec Utilities at additional cost.
- 3. Design and engineering services for aspects of the project not included in this Scope of Supply and Design Submittal**
  - a. Site engineering, site drawings, electrical service design and plans.
  - b. Construction meetings not directly related to the pump station.
  - c. Design/specification of delivery or installation space, equipment, safety.
  - d. Review of any documents supplied by any party other than Romtec Utilities.
- 4. Construction services**
  - a. Romtec Utilities personnel at the project site during installation of underground components are there only in an advisory capacity.
  - b. Romtec Utilities does not perform work during this phase of the project, unless such work is specified in the Scope of Supply.
- 5. Electrical services**
  - a. Romtec Utilities does not perform or advise on the performance of any electrical services that must be performed by a licensed electrical contractor.

## 3.02

## SERVICES NOT SUPPLIED BY ROMTEC UTILITIES

### 6. Start-up, testing & training services

- a. Romtec Utilities' standard start-up, testing and training services are based solely on the pre-specified operational parameters contained in this Scope of Supply and Design Submittal.
- b. Additional start-up, testing and/or training services requested or required by the regulatory agency or any other party will not be conducted by Romtec Utilities.

**END  
OF  
SECTION**

## **4. DESIGN CRITERIA**

The information submitted for the Romtec Utilities design within this document is explained and organized in this section. The design criteria was submitted by the person(s) stated in Section 4.01 not Romtec Utilities itself.

This section is structured as follows:

4.01 INTRODUCTION TO DESIGN CRITERIA

4.02 LIFT STATION DESIGN CRITERIA FORM

**4.01****INTRODUCTION TO DESIGN CRITERIA**

Romtec Utilities has created this Scope of Supply and Design Submittal solely on the basis of the design criteria listed on the attached Lift Station Design Form. The design criteria are identified as:

Project Name: Indian Springs Stormwater

Design criteria supplied by: Company Name

Design criteria date: 9/16/2013

**CAUTION!** By approval of and/or use of this Romtec Utilities Scope of Supply and Design Submittal, the customer and/or the customer's representative agrees that Romtec Utilities has correctly based this scope of supply and this design of the pump station on the exact design criteria listed on the attached Lift Station Design Form.

Romtec Utilities has not checked the information listed on the Lift Station Design Form. Romtec Utilities does not have responsibility for checking this information or confirming its accuracy. This information has been accepted as fact by Romtec Utilities.

**NOTE:** The pump station will perform as designed, only if the design criteria stated in the Lift Station Design Form represent the actual conditions at the project site. If the project site's actual conditions are, in any way, different from the design criteria supplied to Romtec Utilities, then the pump station could perform differently than stated or not perform at all.

**IMPORTANT!** Romtec Utilities has relied on the design criteria supplied by the customer and/or the customer's representative (listed on the Lift Station Design Form) as the only information forming the basis for design of the pump station described herein.

Additional information about this project, including agencies' standards, bid documents, design drawings and other documents, may have been available to and/or supplied to Romtec Utilities. Romtec Utilities may have studied such information; however the pump station design represented by this Scope of Supply and Design Submittal is based solely on the design criteria listed on the attached Lift Station Design Form.

Romtec Utilities makes no claim as to whether or not the pump station described herein will meet any agency's standard, any bid document or any other document. Romtec Utilities is not responsible for making such a determination.

**Romtec Utilities, Inc.**

18240 North Bank Rd. • Roseburg, OR 97470

541-496-9678 • [www.romtecutilities.com](http://www.romtecutilities.com)

## 4.02 LIFT STATION DESIGN CRITERIA FORM

Romtec Utilities has designed this Scope of Supply and Design Submittal based on the following information:

Design Criteria  
Date: 9/16/2013

### PART 1: PROJECT CONTACT INFORMATION

Information here in provided by:	Company Name					
Company/Agency Type:	<table border="0" style="width: 100%;"> <tr> <td style="border: 2px solid black; padding: 2px;">Engineer</td> <td style="padding: 2px;"><u>Engineer</u></td> <td style="padding: 2px;"><u>Developer</u></td> <td style="padding: 2px;"><u>Gov't. Agency</u></td> <td style="padding: 2px;"><u>Other</u></td> </tr> </table>	Engineer	<u>Engineer</u>	<u>Developer</u>	<u>Gov't. Agency</u>	<u>Other</u>
Engineer	<u>Engineer</u>	<u>Developer</u>	<u>Gov't. Agency</u>	<u>Other</u>		
First Name:	<u>John</u>					
Last Name:	<u>Doe</u>					
Title:	<u> </u>					
Email Address:	<u><a href="mailto:jdoe@company.com">jdoe@company.com</a></u>					
Address:	<u>111 Road Street</u>					
City:	<u>Santa Rose</u>					
State/Province:	<u>California</u> Zip Code: <u>95401</u>					
Country:	<u>USA</u>					
Telephone:	<u>888-111-2222</u> Phone Ext: <u> </u>					
Mobile/Other Phone:	<u> </u> Fax: <u> </u>					
Project Name:	<u>Indian Springs Stormwater</u>					
Your Client for this project is:	<table border="0" style="width: 100%;"> <tr> <td style="border: 2px solid black; padding: 2px;">Private Co.</td> <td style="padding: 2px;"><u>Public Agency</u></td> <td style="padding: 2px;"><u>Private Co.</u></td> </tr> </table>	Private Co.	<u>Public Agency</u>	<u>Private Co.</u>		
Private Co.	<u>Public Agency</u>	<u>Private Co.</u>				
Project Type:	<table border="0" style="width: 100%;"> <tr> <td style="border: 2px solid black; padding: 2px;">Stormwater</td> <td style="padding: 2px;"><u>Wastewater</u></td> <td style="padding: 2px;"><u>Stormwater</u></td> <td style="padding: 2px;"><u>Other</u></td> </tr> </table>	Stormwater	<u>Wastewater</u>	<u>Stormwater</u>	<u>Other</u>	
Stormwater	<u>Wastewater</u>	<u>Stormwater</u>	<u>Other</u>			
Project City:	<u>Santa Rosa</u> Project Zip: <u> </u>					
Project Engineer:	<u>John Doe</u>					
Reviewing Entity who reviews/approves this Scope of Supply & Design Submittal:	<u>Company Name</u>					
Final Project Owner and/or Operator:	<u> </u>					
Governing Sewer or Water Authority:	<u> </u>					
Does Authority have a lift station standard?	<table border="0" style="width: 100%;"> <tr> <td style="border: 2px solid black; padding: 2px;">SELECT ONE</td> <td style="padding: 2px;"><u>Yes</u></td> <td style="padding: 2px;"><u>No</u></td> <td style="padding: 2px;"><u>N/A</u></td> </tr> </table>	SELECT ONE	<u>Yes</u>	<u>No</u>	<u>N/A</u>	
SELECT ONE	<u>Yes</u>	<u>No</u>	<u>N/A</u>			
Who should Romtec contact about the lift station design standard?	<u> </u>					
What is the Expected Project Bid Date?	<u> </u> Project Completion Date: <u> </u>					



## 4.02 LIFT STATION DESIGN CRITERIA FORM

### PART 2: DESIGN DATA

If using assumed elevations, note this in Additional Information.

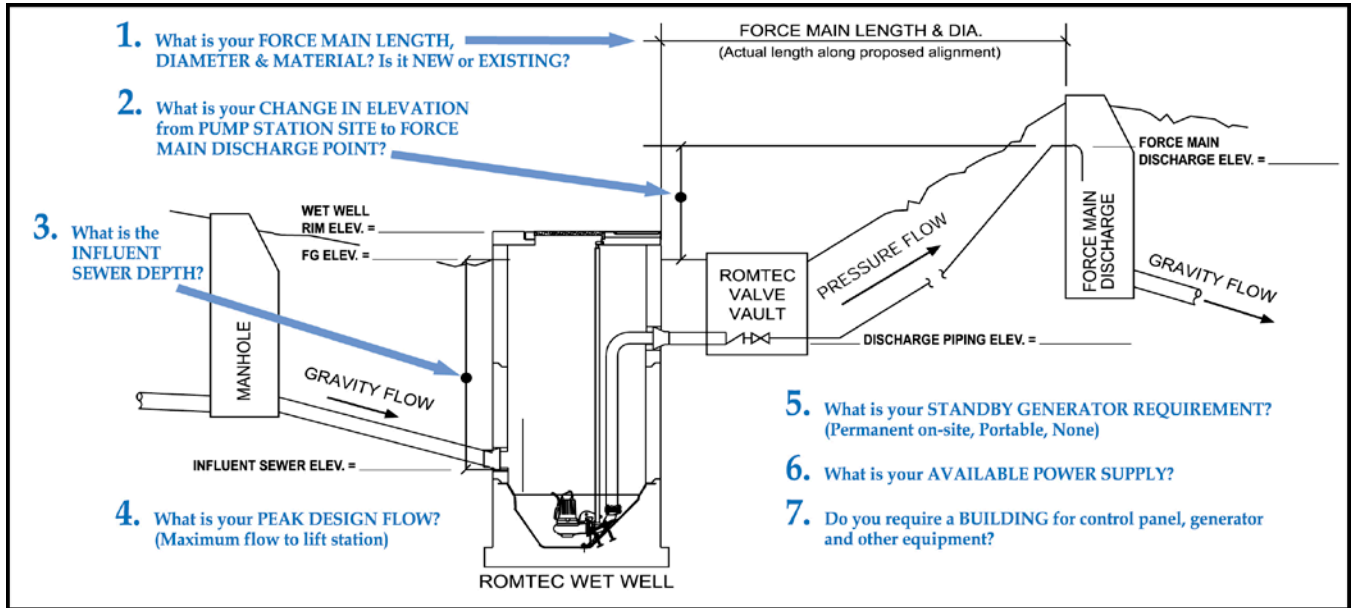

<b>1.</b> Force main length:	<u>76</u> ft.	(actual length along proposed alignment)		
Force main diameter (inside):	<u>18</u> in.	inside dia.		
Force main material (i.e., PVC C-900 class 150, ductile iron class 52, HDPE DR17 class 100, etc.):	<u>PVC C905</u>			
Force Main is:	<input checked="" type="checkbox"/> <u>New</u>	<u>New</u>	<u>Existing</u>	
<b>2.</b> Elevation change from lift station site to force main discharge point:	<u>-0.37</u> ft.			
Finish grade elevation at wet well:	<u>351.4</u> ft.			
Discharge piping elevation at valve vault:	<u>347.4</u> ft.			
Force main discharge elevation:	<u>351.03</u> ft.			
<b>3.</b> Influent sewer elevation:	<u>345.12</u> ft.			
<b>4.</b> Peak design inflow (maximum flow to lift station):	<u>6800</u> g.p.m.			
<b>5.</b> Standby generator requirement:	<input checked="" type="checkbox"/> <u>None</u>	<u>Permanent</u>	<u>Portable</u>	<u>None</u> <u>Don't Know</u>
Standby generator fuel:	<input type="checkbox"/>	<u>Diesel</u>	<u>Natural Gas</u>	<u>Propane</u>
<b>6.</b> Available power supply:	<input checked="" type="checkbox"/> <u>480V</u>	<u>208V</u>	<u>240V</u>	<u>480V</u>
	<input checked="" type="checkbox"/> <u>3-phase</u>	<u>Single-phase</u>	<u>3-phase</u>	
Additional loads on site (besides the lift station) to be powered by generator:	<u>                    </u>	KVA		

**END  
OF  
SECTION**

## 5. SITE PLAN

The location of any project is critical in design. This section includes:

### 5.01 SITE SPECIFIC CONDUIT & WIRE LAYOUT LIMITATIONS

#### **No site plan has been provided to Romtec Utilities in AutoCAD.**

If and when we receive a site plan (in AutoCAD) showing the orientation of the influent lines, force main and lift station, Romtec Utilities will provide a proposed layout (to scale) of its equipment on the site.

Without a site plan, Romtec Utilities can only assume that its design is correct relative to site constraints and orientations.

If a site plan in AutoCAD is not provided to Romtec Utilities, any site layouts are by others.

If the Romtec Utilities Scope of Supply and Design Submittal or the Scope of Supply, Design and Installation Submittal does not have an approved site plan which includes the Romtec Utilities equipment layout on the site, then we will not be involved in any part of the utility layout.

It is okay if the site plan (in AutoCAD format) is not provide, but if it is not, Romtec Utilities will not design or advise on any part of the site utility plan. For example, Romtec Utilities will not recommend conduit sizing, wiring sizing, conduit layout, wet well to valve vault spacing or control panel placement, etc.

If this site plan section is not complete, the responsibility for the physical layout of the Romtec Utilities lift station and all wet and dry utilities is by others.

Any difficulties that arise due to the lack of an approved site plan with an approved layout of the Romtec Utilities supplied equipment is the responsibility of the owner.

**If anyone other than Romtec Utilities provides a layout of the Romtec Utilities equipment on the site plan, any difficulties that may arise due to incorrect layout of the equipment is not Romtec Utilities responsibility.**

## 5.01

## SITE SPECIFIC CONDUIT AND WIRE LAYOUT

Romtec Utilities does not provide a site specific (to scale) layout of the electrical conduit and wire which interconnects the Romtec Utilities supplied equipment on your site.

Each job is site specific and under the jurisdiction of the local utility and local inspectors. We (Romtec Utilities) are not providing the conduit or the wire and we are not licensed electricians who are performing the field installation of the actual conduit and wire.

**What Romtec Utilities does provide for you and your electrician is the following.**

1. Section 11.01 – Typical Field Wiring Plan.

*Note: This drawing reflects the electrical interconnection from the Romtec Utilities control panel to the Romtec Utilities supplied field devices.*

2. Section 12.05 – One Line Drawing.

*Note: This drawing aids in the understanding and installation of the overall control system.*

### CONCLUSION

Complete field wiring and installation instructions are not included in the Romtec Utilities Scope of Supply and Design Submittal. Instead, the correct installation and conformance to all applicable codes is the responsibility of the installer and/or their electrician.

**END  
OF  
SECTION**

## **6. WARRANTY & LIMITATIONS ON WARRANTY**

This section includes all warranty information for Romtec Utilities products and services.

This section is structured as follows:

- 6.01 ROMTEC UTILITIES LIMITED WARRANTY
- 6.02 LIMITATIONS OF ROMTEC UTILITIES' RESPONSIBILITIES

### **Romtec Utilities Limited Warranty**

Romtec Utilities, Inc. (herein referred to as "Romtec Utilities") warrants that the equipment supplied will be free from defects in material and workmanship under normal use and service, when used in accordance with Romtec Utilities' procedures as set forth below for a period of one year from date of acceptance (acceptance is defined as the date Romtec Utilities' "Start-Up" report is completed) or one year and six months from installation of the wet well (or delivery of the wet well or the date that the wet well was ready to deliver), whichever comes first. The obligation of Romtec Utilities under this warranty is limited to replacing or repairing any defective part (failure of other manufacturer supplied components will be addressed according to the individual manufacturer's warranty, the periods of which, and the manufacturer's obligations therein may differ from Romtec Utilities' Warranty). This warranty extends only to Romtec Utilities' direct customer (as named in the Romtec Utilities Purchase Order), herein called "customer", and not to any person or entity with whom customer has business relationships, or any party other than customer.

**THIS WARRANTY IS IN LIEU OF ALL OTHER WARRANTIES, EXPRESS OR IMPLIED, INCLUDING BUT NOT LIMITED TO THE IMPLIED WARRANTIES OF MERCHANTABILITY AND FITNESS FOR PURPOSE, WHICH IMPLIED WARRANTIES ARE EXCLUDED. ROMTEC SHALL NOT BE LIABLE FOR CONSEQUENTIAL OR INCIDENTAL DAMAGES.**

#### **Components resold or supplied with Romtec Utilities materials**

Certain components are warrantable directly by the original manufacturer for periods between 90 days and 5 years. Replacement for, repair or refund of defective workmanship or material under normal use shall be remunerated directly with the manufacturer of the component. Examples of components would be generators, manual cranes, pumps, pump controls, valves, etc.

#### **Warranty voidable**

Romtec Utilities' representative must be on-site for oversight of assembly during installation of the wet well. Wet Well installation that is performed without the presence of a Romtec Utilities' representative shall void all warranties related to the wet well structure and its performance.

Start-up that is performed without the presence of a Romtec Utilities' representative shall void all warranties.

#### **Claims of defective manufacture**

Claims that the merchandise was incorrectly manufactured or that is defective in any way must be made directly to Romtec Utilities on a product-by-product basis. All claims must be made within 72 hours of the defective condition, or the time when the defect should have been discovered, whichever is earlier. All claims must include the following:

1. A detailed description of the specific problem, failure, or other event giving rise to the claim; and
2. Supporting photographs or videos; and
3. Specific location; and
4. Names and phone numbers of individuals who can substantiate the claim, but who do not work for contractor.

**Failure of pump station**

Romtec Utilities pump stations pump all types of water containing all kinds of materials. Sometimes pumps may clog or power may be lost and the pump station will fail to operate. If your station fails to operate, Romtec Utilities will suggest a local service company to evaluate the problem. If it is a warranty issue, Romtec Utilities will repair and/or replace per the terms of this warranty. If however, the pumps are simply "clogged" or the power is simply lost Romtec Utilities will advise you that it is not a warranty issue and you will simply pay for the service call and the associated services.

**Action in event of established claim**

In the event it is determined that goods have been incorrectly manufactured or are defective, the liability of Romtec Utilities shall be limited to, at its option, repair or replacement of the goods. Romtec Utilities also reserves the right to establish reasonable time limits for completion of any specific installation tasks resulting from the replacement of defective merchandise.

**No third party claims**

Under no circumstances shall Romtec Utilities be responsible for any damage claims by any party other than claims by Romtec Utilities direct customers.

**Release and hold harmless**

Contractor releases and agrees to defend, indemnify, and hold Romtec Utilities harmless from and against any and all claims, demands, actions, and causes of action for any matters arising out of or connected with the materials whereby the contractor is responsible for errors or omissions.

**FURTHER LIMITATIONS ON ROMTEC LIABILITY****1. Specific limitations**

- a. Romtec Utilities' liability under the foregoing warranty and under the transaction of which this document is a part is limited as follows:
- b. Romtec Utilities has designed the lift station supplied under this project to meet a specific design standard and specific set of parameters as dictated to Romtec Utilities by its customer as set forth in the "Lift Station Design Form" located in section 4 of the Romtec Utilities Scope of Supply and Design Submittal.
- c. Romtec Utilities' Scope of Supply & Design Submittal is a part of and limited by CUSTOMER'S site civil and electrical plans.
- d. Romtec Utilities makes no guarantees that any of its supply will fit on customer's site and/or building. However, at customer's request, Romtec Utilities will provide suggested layouts for the customer's project. Ultimately, the customer decides to accept or reject any given layout.
- e. Romtec Utilities cannot make final layout or equipment placement judgments at the site (i.e. generator or control panel "fit" in or out of a building). It is the responsibility of customer's site engineer and contractor to check dimensions, etc. If customer has not accepted (or received) final dimensions, etc., please request further definition before approval. Romtec Utilities is not responsible for items that do not fit on the site.



## 6.01

## ROMTEC UTILITIES LIMITED WARRANTY

- f. It is Romtec Utilities' customer's responsibility and obligation to review Romtec Utilities' Scope of Supply & Design Submittal to insure it meets with customer approval relative to any customer third party agreements.
- g. Romtec Utilities is not responsible for any aspect of the construction/installation of the Romtec Utilities lift station. The Contractor bears sole responsibility for installation of products manufactured by Romtec Utilities. The Romtec Utilities Scope of Supply and Design Submittal defines Romtec Utilities scope of supply relative to equipment, documentation, start-up services and warranty.
- h. If Romtec Utilities is on site during the construction/installation of the Romtec Utilities lift station it is only as an advisor. Romtec Utilities is never on site to perform any construction and/or installation tasks.
- i. Romtec Utilities designs and prefabricates its lift station system to enable contractors to install the Romtec Utilities system quickly and completely. However, Romtec Utilities has made no representation and/or claims as to "how long" it will take to construct/install the Romtec Utilities system.
  - i. *Note: If any Romtec Utilities-supplied part is found to be defective and/or has been manufactured in error relative to this document, Romtec Utilities will repair and/or replace that part at Romtec Utilities' expense. Romtec Utilities does not offer, nor will Romtec Utilities accept, any charges and/or claims by anyone relative to the time it takes to install/construct the Romtec Utilities system and or claims for delays relative to a part that has to be repaired and/or replaced by Romtec Utilities.*
- j. Romtec Utilities' responsibility is to its direct customer. We want to help all parties, but we are ultimately responsible only to our direct customer.
  - i. If Romtec Utilities' direct customer has hired a sub-contractor Romtec Utilities will communicate with that sub-contractor through a representative of Romtec Utilities' direct customer.

### IN OTHER WORDS

Romtec Utilities will not direct and/or advise any sub-contractor. Instead, Romtec Utilities will communicate directly with its "direct customer" and they will communicate with their sub-contractors, engineers, and/or owners.

- k. The Romtec Utilities design reflects all elevations and/or orientations to an accuracy of and/or minus .10'. Romtec Utilities does not claim to manufacture any aspect of its lift station systems to absolute elevations. It is simply not possible in the general underground construction world to meet absolutes. Therefore, any owner and/or installer of a Romtec Utilities system is accepting the Romtec Utilities system proposed herein to the plus or minus .10' offered by Romtec Utilities.

## 2. Performance Characteristics and Start-Up.

- a. The lift station is a sophisticated device that can be operated in many different ways. The Romtec Utilities Scope of Supply & Design Submittal defines Romtec Utilities' approach to the operation of the lift station.

## 6.01

## ROMTEC UTILITIES LIMITED WARRANTY

- i. Note: While there are many ways to vary and/or adjust "operational parameters" within the overall lift station, Romtec Utilities is only prepared to start-up per its own parameters (as specified in the customer's design criteria, see attached).*
    - b. Romtec Utilities' obligation is to show that the station can run as designed to meet specific design criteria as shown in its Scope of Supply & Design Submittal. It is understood that the regulating agency may want to test many other scenarios. This will not be part of the standard Romtec Utilities' start-up procedures and training. At start-up, Romtec Utilities will only prove that the station can run at the pre-specified design parameters.
    - c. Romtec Utilities is not an operator, installer or an electrical interconnector for the lift stations and equipment it supplies.
    - d. During start-up, Romtec Utilities is completely in charge. Romtec Utilities' start-up technician will start-up and "prove" the station per the approved Romtec Utilities Scope of Supply & Design Submittal. After the lift station is accepted other parties may choose to adjust and/or vary the operational parameters to suit their specific preference. However, Romtec Utilities will not be involved with these issues either during or after start-up, and is not responsible for problems arising from any adjustments or variations by such other parties.
- 3. Training.**
- a. Romtec Utilities will perform system training at no additional cost as part of its scope of supply if the training is scheduled for the day after start-up. If training is scheduled for any other time than the day after start-up, Romtec Utilities will require prepayment of the additional costs (incurred as a result of the need to reschedule) prior to confirming the alternate training schedule. If training is scheduled for any other time other than the day after start-up, Romtec Utilities will require prepayment of the additional costs incurred as a result of the need to reschedule.

## 6.02

# LIMITATIONS OF ROMTEC UTILITIES' RESPONSIBILITIES

- 1. Romtec Utilities is the equipment supplier only**
  - a. Unless specified otherwise in this document, Romtec Utilities is not a subcontractor and does not perform any installation or construction tasks at the project site, unless those duties are specified in this document.
  - b. Romtec Utilities staff persons at the project site are there strictly to observe and advise.
  
- 2. Romtec Utilities' responsibilities are to its direct customer only**
  - a. Romtec Utilities will communicate with project subcontractors, engineers, owners and any other parties only through a designated representative of the customer.
  
- 3. The pump station design is based, solely, on information supplied to Romtec Utilities and listed in the Lift Station Design Form**
  - a. All site-related data are the responsibility of the customer, not Romtec Utilities.
  
- 4. Complete review of this document will require information contained in other documents not supplied by Romtec Utilities**
  - a. Romtec Utilities does not supply various documents related to the project, such as: the pump station site plan, the area plan, the influent line and force main plan and profile, the electrical plan and many other documents.
  - b. Thorough understanding of the environment in which the pump station will be installed and operated requires complete knowledge of information included in these related documents.
  - c. Romtec Utilities does not know any information included in any of these other documents, except those specific design details included in the Lift Station Design Form.
  
- 5. Romtec Utilities is not responsible for the review or understanding of this document by the customer, the customer's representatives or agents, engineers and installation contractor/subcontractors**
  - a. The customer, engineers, installation contractor/subcontractors, owner and all other parties interested in the project are urged to contact Romtec Utilities Document Control, at any time, with any questions they may have about the system described herein, or about Romtec Utilities' responsibilities related to the project.
  - b. Romtec Utilities will make every effort to ensure that all parties have access to complete information about the pump station; however, Romtec Utilities is not responsible for the distribution of this document and/or

## 6.02

# LIMITATIONS OF ROMTEC UTILITIES' RESPONSIBILITIES

misunderstandings, errors and costs that arise from an incomplete understanding, by any party, of the information contained in this document.

### 6. Sealing of documents will incur additional charges

- a. Romtec Utilities has not offered to “seal” the Scope of Supply and Design Submittal, including drawings contained herein.
- b. Sealing of this document and/or the providing of sealed plans and/or sealed calculations are available from Romtec Utilities, if required, at additional cost.

### 7. Installation/construction time is not specified

- a. Romtec Utilities designs and manufactures its pump station systems for quick and complete installation. However, Romtec Utilities makes no representation as to how long it will take to prepare the site, install the system described herein, connect the system to other equipment not supplied by Romtec Utilities or to start-up and complete the system.
  - i. *Note: By approving the Romtec Utilities' Scope of Supply and Design Submittal, the customer agrees to reimburse Romtec Utilities for any cost incurred, whether by Romtec Utilities directly or through a related vendor, due to on-site delays caused by inaccurate representation herein.*

### 8. Installation time and/or defective or incorrect parts do not justify delay claims

- a. If, at the time of installation, any part supplied by Romtec Utilities is found to be defective or incorrect, relative to this document, Romtec Utilities will repair and/or replace said part at Romtec Utilities' expense.
- b. Romtec Utilities does not accept any charge and/or claim by anyone, related to the time it takes to install/construct the Romtec Utilities system and/or claims for delays related replacement or repair of any part of the system by Romtec Utilities.

### 9. Final (As Built) size for the control panel enclosure

- a. The size of the final (as built) enclosure for the control panel may change! In other words, the size of the panel enclosure (as proposed) in this Romtec Utilities' Scope of Supply and Design Submittal may not be the actual size and/or mounting style of the final (as built) panel and enclosure.
  - i. *Note: The final as built drawings will not be available until at least 3 to 4 weeks following Romtec Utilities' receipt of Notice to Proceed from its direct customer. Any changes to the enclosure size will result in notification from Romtec Utilities to its direct customer.*

## 6.02

# LIMITATIONS OF ROMTEC UTILITIES' RESPONSIBILITIES

- 10. Romtec Utilities Pre-construction Checklist has suggestions only**
  - a. All references to installation preparations, methods and/or equipment contained in the Romtec Utilities Installation Checklist or any other Romtec Utilities document are only suggestions, not directions.
  
- 11. Romtec Utilities is not responsible for determining the methods and equipment used in site preparation and/or installation/construction**
  - a. All methods and equipment used at the site are the responsibility of the installation contractor/subcontractors, not Romtec Utilities. The contractor/subcontractor bears sole responsibility for installation of products manufactured by Romtec Utilities.
  - b. Romtec Utilities does not know or specify what site preparation methods should or will be used, for example: whether or not excavated areas will require shoring or dewatering, what backfill methods will be required or any other site-related aspects of the project.
  - c. Romtec Utilities does not specify and does not know what types of equipment the installation/construction contractor and/or subcontractors plan to use at the site.
  - d. Romtec Utilities does not know the suitability of any equipment for installation of products supplied by Romtec Utilities.
  
- 12. Romtec Utilities is not responsible for structural testing done after backfill**
  - a. The customer is responsible for any water or vacuum testing conducted on underground vessels.
  - b. Romtec Utilities recommends any and all testing of the underground structures occur prior to backfill. Romtec Utilities is available to assist with any repairs after testing is done, prior to backfilling the structures.
  - c. If testing takes place after backfilling has occurred, Romtec Utilities ability to assist with repairs is severely limited. Romtec Utilities will not assume costs caused by testing after backfill.
  
- 13. Installing a level and "plumb" wet well that will not "settle"**
  - a. The specification for and the process for creating a stable compacted "footing" or "base" for the Romtec Utilities wet well to be placed on is by others.
  - b. In other words, creating a compacted base that will not allow the Romtec Utilities wet well to "settle" and/or "tilt" during or after installation is not the responsibility of Romtec Utilities.

## 6.02

**LIMITATIONS OF ROMTEC UTILITIES'  
RESPONSIBILITIES**

- c. Romtec Utilities wants every installation contractor to be successful. We want every wet well to be plumb, level and to never settle. Romtec Utilities however is not responsible for any of these "installation" related problems if they occur.
- 14. A Romtec Utilities advisor will be at the project site during installation of the pump station's underground components**
- a. Any Romtec Utilities personnel at the project site during installation of the pump station's underground components are there only in an advisory capacity. Romtec Utilities does not perform work during this phase of the project, unless such work is specified in the Scope of Supply.
  - b. To facilitate communication about the project, the Romtec Utilities Advisor may be at the project site or available by telephone or other electronic means.
- 15. Getting ready for the Romtec Utilities construction advisor and the delivery of the Romtec Utilities system for installation**
- a. Typically the Romtec Utilities delivery of the underground portion of the Romtec Utilities system is done in conjunction with its installation. In other words, the Romtec Utilities system is unloaded from the Romtec Utilities trucks and installed directly into the prepared hole.
  - b. Our goal is to save you (or your contractor) time and money. One way to do this is to deliver and install the underground portion of the Romtec Utilities system on the same day (from the Romtec Utilities' delivery truck to the prepared excavation).
  - c. Therefore, when Romtec Utilities schedules its construction advisor to be on-site we assume that the hole will be excavated, the base of the hole prepared, and any shoring will be installed.
    - i. *Note: The Romtec Utilities "Installation Checklist" is the document that Romtec Utilities is relying on. We assume that all of the work on the Installation Checklist will be done and all equipment, etc will be on site and ready to install on the day Romtec Utilities arrives.*
    - ii. *Note: Normally our trucks will arrive the night before and along with our construction advisor, we will be "ready to go" on the day of the scheduled delivery and installation.*
    - iii. *Special Note: If the job as scheduled and as defined in the Romtec Utilities' "Installation Checklist" located in this Romtec Utilities' Scope of Supply and Design Submittal is not really "ready to install", Romtec Utilities will require a change order to reschedule its construction advisor at a later date.*

## 6.02

LIMITATIONS OF ROMTEC UTILITIES'  
RESPONSIBILITIES**16. Delivery/Installation/Start-up delays**

- a. When the Customer schedules delivery of the system and/or Romtec Utilities and its suppliers to be on-site for either the “construction” and/or the “start-up and training”, the customer agrees to additional charges if any of the following occur.
  - i. In the event that the shipment is cancelled after the truck has been loaded, there will be a cancellation fee, unless the shipment is rescheduled for the same day.
  - ii. Any undue delay in unloading of trucks (over 2 hours per truck) will result in a waiting time fee.
  - iii. If Romtec Utilities discovers upon arrival that the customer is not ready to construct or start-up.
    1. *Note:* Romtec Utilities works very hard to confirm the customers “readiness” to construct and/or start-up. If we ultimately find (upon arrival) that the system is not ready for either, we will leave the site and reschedule at a later date for an additional charge.
    2. *Special Note:* Having the Romtec Utilities construction advisor and start-up technician on-site helps everyone complete the project without difficulty. We provide these on-site services as part of our price, but we rely on the customer to confirm that they are ready for us to perform.
  - iv. The customer chooses to cancel or reschedule the construction and/or changes the date after Romtec Utilities and/or its vendor have purchased tickets for travel, etc.
  - v. If the installation and/or start-up is delayed for any reason and runs into a weekend or holiday, keep in mind that the Romtec Utilities offices will be closed and there will be no one available for technical support.

**17. Romtec Utilities does not perform or advise on performance of any electrical installation work**

- a. All electrical installation work on the project site must be performed by a licensed electrical contractor. Romtec Utilities personnel are generally not on the project site during electrical installation.
- b. A licensed electrical contractor must be onsite during the entirety of the Romtec Utilities start-up training (see 6.02.22).

## 6.02

## LIMITATIONS OF ROMTEC UTILITIES' RESPONSIBILITIES

- 18. Start-up Preparation Form must be completed by the customer and returned to Romtec Utilities before start-up and testing day will be scheduled**
  - a. To expedite timely and efficient completion of the pump station, Romtec Utilities will schedule start-up and testing approximately two weeks after receipt of the completed Pre Start-up Checklist from the customer indicating all work has been done to prepare for station start-up and testing.
  
- 19. Romtec Utilities directs the pump station start-up and testing**
  - a. The Romtec Utilities technician directs all station start-up and testing procedures. No other party shall operate the station until after the start-up and testing procedures are completed by Romtec Utilities.
  - b. Romtec Utilities requires the presence of the licensed electrical contractor who installed the pump station's electrical system at the project site during pump station start-up and testing.
    - i. *Note: If all necessary field wiring is not completed at the time of start-up, Romtec Utilities reserves the right to charge for our time required to complete the wiring.*
  
- 20. System start-up, testing and training services are limited to the operational parameters described in this Scope of Supply and Design Submittal**
  - a. The pump station described herein is a sophisticated device that can be operated in many different ways; however this document defines only a specific set of operational parameters.
  - b. Romtec Utilities' standard start-up, testing and training services are based solely on these pre-specified operational parameters. Additional start-up, testing and/or training services requested or required by the regulatory agency or any other party will not be conducted by Romtec Utilities, unless those services are included in this Scope of Supply and Design Submittal.
  
- 21. Additional start-up/training time by Romtec Utilities and/or any Romtec Utilities supplier**
  - a. Any additional time required of Romtec Utilities (other than the time and/or services outlined in this Scope of Supply document and/or as part of the purchase order) must be ordered and contracted separately from this purchase order. Romtec Utilities will require a change order or a separate purchase order for any additional time.
  - b. If more time is required of any Romtec Utilities supplier (other than the time and/or services outlined in this Scope of Supply document and/or as part of the purchase order) the Customer must order it directly from that supplier, not Romtec Utilities.



## 6.02

**LIMITATIONS OF ROMTEC UTILITIES'  
RESPONSIBILITIES**

- 22. The schedule for standard pump station start-up and operation and maintenance training is limited**
- a. Romtec Utilities has provided two (2) contiguous days (not including holidays or weekends) for pump station start-up and operation and maintenance training as part of the standard services included in this Scope of Supply.
    - i. Note: *This is only if the operation and maintenance training is scheduled for the day after the pump station start-up is conducted.*
  - b. If training is scheduled for any time other than the day after start-up, Romtec Utilities will charge per day (from the time our technician leaves Romtec Utilities) plus travel and per diem, for the service with a minimum charge of two days. This will result in a change order or additional purchase order.
    - i. Note: *If you have purchased a Romtec Utilities' system and for whatever reason have not elected to have Romtec Utilities "start-up" the system prior to the end of the warranty, start-up services will need to be scheduled and purchased separately.*  
  
*In other word*  
  
*Our "free start-up" services are included with the purchase of the Romtec Utilities' system. We will withdraw the free start-up if you elect to not start-up the system prior to the end of warranty. We will however, be glad to start-up the system at a fee to be quoted when you are ready.*
- 23. Pump station owner and/or owner's designated station operator must receive training for warranty to be to be in place**
- a. The Customer must designate, in advance, the persons who will participate in the pump station operation and maintenance training provided by Romtec Utilities.
  - b. The Romtec Utilities Limited Warranty will not be in place until after the pump station owner and/or the owner's designated station operator have participated in and passed the operation and maintenance training supplied by Romtec Utilities unless Romtec Utilities has not started the system.
  - c. Romtec Utilities does not train the installation contractor in the operation and maintenance of the pump station, unless this installation contractor is designated by the owner as the party responsible for station operation.
- 24. Ongoing operation and maintenance training is the responsibility of the station owner/operator, not Romtec Utilities**
- a. Romtec Utilities does not provide ongoing operation and maintenance training, except for the training specified in this Scope of Supply and Design

## 6.02

# LIMITATIONS OF ROMTEC UTILITIES' RESPONSIBILITIES

Submittal. It is the responsibility of the pump station owner and/or operator to conduct ongoing operation and maintenance of the pump station and its components.

### 25. Failure of pump station-warranty

- a. Pump station function is a complex combination of parameters. Sometimes pumps may clog or power may be lost and the pump station will fail to operate. Sometimes the failure is caused by mechanical or sometimes it's electrical. A pump station failure does not constitute a warranty issue. In order to make a warranty claim follow this procedure:
  - i. Trouble-shoot the problem with the help of Romtec Utilities over the phone.
  - ii. If you cannot provide trouble shooting assistance Romtec Utilities can recommend a local company to provide trouble-shooting assistance at your cost.
  - iii. Once the cause of the failure has been determined then a warranty claim can be made. Warranty claims extend to defective parts only. Romtec Utilities does not warranty trouble shooting, service calls, installation or re-installation associated with defective parts or their failure. Romtec Utilities will repair and/or replace per the terms of the Romtec Utilities warranty.

1. *Note:* *If however no parts have failed and let's say that the pumps are simply "clogged" or the power was simply lost, Romtec Utilities will advise the owner that this is not a warranty issue and the owner will be responsible for payment of the service call and the associated services.*

### 26. Start-up after the warranty expires

- a. Romtec Utilities start-up, testing and training services are included at no additional cost if these services are performed within 18 months of the delivery, or deliverability of the lift station per its accepted purchase order. If start-up services are required after this period they will not be free and/or included as part of the accepted purchase order. Instead they will be quoted and ordered under a new and separate quote and service order.

### 27. Special cases if start-up is waved

- a. If for any reason an exception is allowed and there is not start-up and training, Romtec Utilities will keep the cost for start-up for engineering burdens that will be associated with not having a Romtec Utilities representative onsite.

## 6.02

# LIMITATIONS OF ROMTEC UTILITIES' RESPONSIBILITIES

### **28. Storage of electrical components and/or pumps prior to start-up**

- a. Romtec Utilities will keep the lift station electrical components and/or pumps at its facility prior to start-up. However, if the customer does not schedule start-up within 4 months after the installation of the underground components, and all components are fully paid for, Romtec Utilities will ship these components to the customer.

### **29. Start-up and training attendance**

- a. The Romtec Utilities start-up technician is on-site to train the lift station personnel on operation and maintenance of the lift station. It is vital that these personnel attend the entire session. If the personnel leave before training completion, additional training requested will be quoted and ordered under a new and separate quote and service order.

**END  
OF  
SECTION**

## **7. OPERATION & MAINTENANCE (O&M) MANUAL**

The Romtec Utilities Operation & Maintenance Manual will be delivered at start-up of the system. This document contains all the as-built drawings and operation, maintenance manuals & manufacturers warranties for the associated mechanical.

One (1) electronic copy and one (1) hard copy (upon request) of the Romtec Utilities Operation & Maintenance Manual will be provided to the customer at start-up of the system.

Any request for additional copies will result in additional fees and a change order.

**END  
OF  
SECTION**

## **8. WET WELL & RELATED EQUIPMENT**

This section contains information pertaining to the wet well. There is both technical information and related drawings necessary for the wet well construction.

This section is structured as follows:

- 8.01 WET WELL COMPONENT DRAWING(S)
- 8.02 WET WELL PRODUCTION DRAWING(S)
- 8.03 WET WELL HATCH DRAWING
- 8.04 WET WELL WEIGHTS & LIFTING DEVICES
- 8.05 WET WELL TESTING FOR WATER INGRESS OR EGRESS
- 8.06 WET WELL RELATED DATA SHEETS
  - 8.06.1 BARREL GASKETS
  - 8.06.2 CONSEAL
  - 8.06.3 TAPECOAT
  - 8.06.4 KOR-N-SEALS
  - 8.06.5 SWING CHECK VALVE
  - 8.06.6 COUPLING ROMAC RFCA
  - 8.06.7 ROMAGRIP ACCESSORY PACK

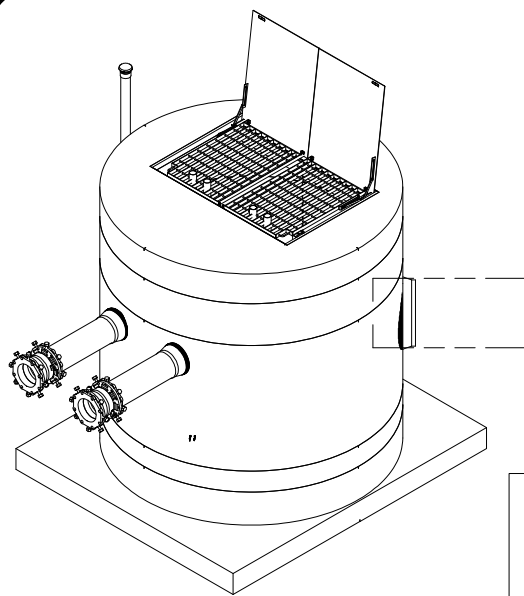

SENSOR AND ELEVATION TABLE		
LEVEL ELEVATION	DISTANCE BETWEEN POINTS	SET POINT DESCRIPTION
345.12		INVERT IN
349.80		BACK UP PUMPS START
	1.00	SENSOR SPACING
348.80		BACK UP PUMPS STOP
	0.00	SENSOR SPACING
348.30		BACK UP HL ALARM
348.80		HIGH LEVEL ALARM
	0.45	SENSOR SPACING
348.35		LAG PUMP START
	1.95	SENSOR SPACING
346.40		LEAD PUMP START
	3.00	SENSOR SPACING
343.40		PUMP STOP
	3.00	DISTANCE TO FLOOR
340.40		FLOOR ELEVATION

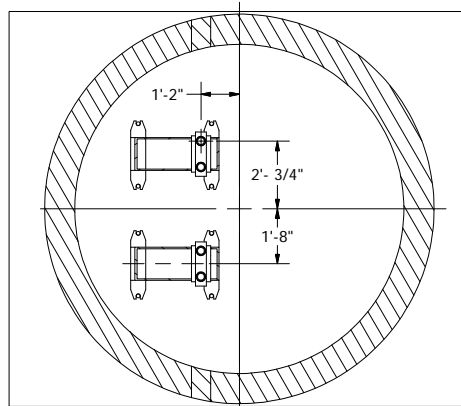

ANCHOR BOLT DETAIL

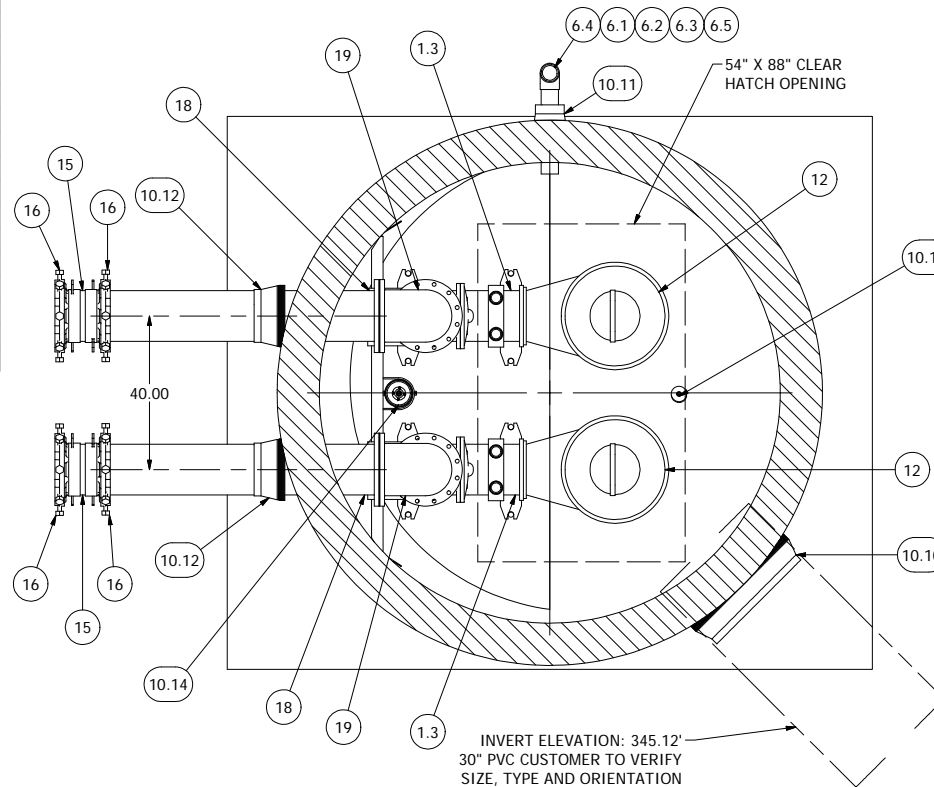

**NOTE: WET WELL TOP SLAB IS PEDESTRIAN RATED**

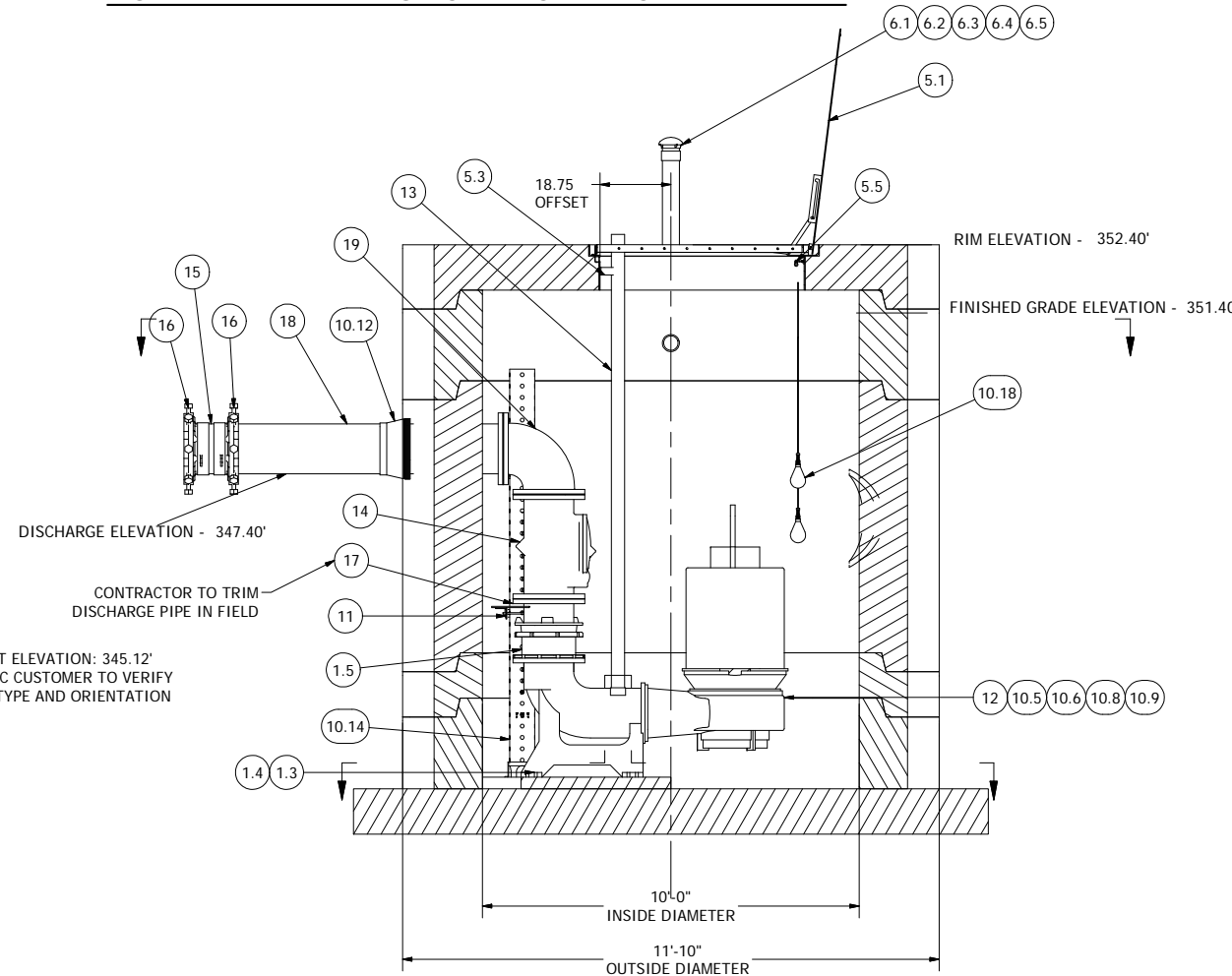
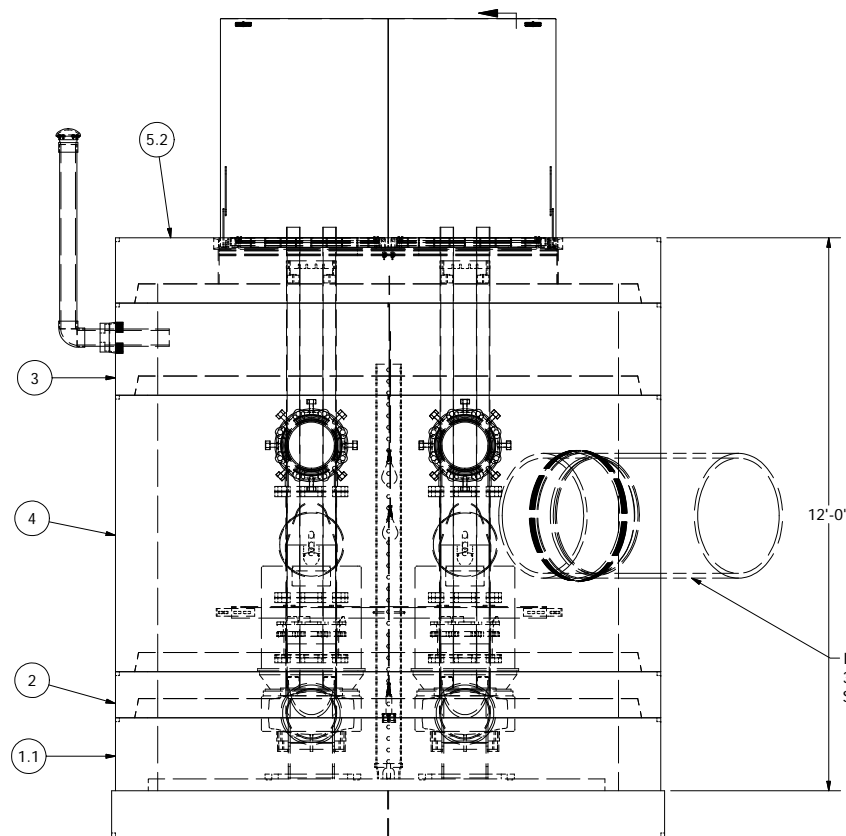

Parts List			
ITEM	QTY	STOCK NUMBER	DESCRIPTION
1	1	10-XXXX	BASE ASSEMBLY
1.1	1	10-5168	BASE - WW - 10ft - RU FLAT BASE - 12ft X 14ft
1.2	1	10-5199	PUMP SHELF - 10ft X 3.125in
1.3	2	31-4872	DISCHARGE ELBOW - 12in - EBARA - LL300Y
1.4	2	31-6040	ANCHOR KIT - DISCHARGE ELBOW (1 3-16in BOLTS)
1.5	2	42-5257	COUPLING - ROMAC - RFCA - 12in FBEC
2	1	12-5901	BARREL - 10ft DIA X 1ft H
3	1	12-5902	BARREL - 10ft DIA X 2ft H
4	1	12-5906	BARREL - 10ft DIA X 6ft H
5	1	14-XXXX	TOP SLAB ASSEMBLY
5.1	1	13-5328	HATCH - WW - 10ft PED - DUPLEX - 55788 - 54 x 88
5.2	1	14-5387	TOP SLAB - WW - 10ft PED - DUPLEX
5.3	2	18-4057	UGBB - 3in - EBARA
5.4	2	18-6031	BOLT & NUT KIT - UPPER GUIDE BAR BRACKET - 3-8in
5.5	2	18-6115	CABLE HANGER ASSEMBLY
6	1	18-5157	4 INCH PVC VENT
6.1	1	18-5427	VENT - MUSHROOM CAP
6.2	1	48-5455	ADAPTOR - 4in SCH80 - MALE THD X SLIP
6.3	1	48-5464	4in PVC - SCH 80 X 24in
6.4	1	48-6264	4 INCH PVC - SCH 80 X 48in
6.5	1	48-6266	ELBOW - PVC - 4in SCH 80 - 90 DEGREE - SLIP X SLIP
7	2	18-6009	DISCHARGE PIPE SUPPORT - WALL BRACKET SET
8	4	18-FAST	DISCHARGE CLAMP BOLT - 1-2 X 1 SS BOLT, WASHER, FIBER LOCK NUT
9	2	18-FAST	DISCHARGE PIPE SUPPORT - BOLT KIT
10	1	18-XXXX	SHIPPING CRATE
10.1	4	12-ROM	BARREL GASKET
10.2	1	18-4874	STILLING WELL SUPPORT BRACKET - STAINLESS
10.3	4	18-6020	LIFTING CLUTCH - 8 TON
10.4	2	32-4643	CORD GRIP - .46 - .56 SS
10.5	2	32-5506	LINK - .62in - OBLONG WELDED CORROSION RES - EBARA PUMPS
10.6	2	32-5943	BOW SHACKLE - 1-2in - SS W-SCREW PIN
10.7	4	32-5999	CHAIN - S5 5-16in 316SS (2 @ 2FT)
10.8	2	32-6065	CORD GRIP - 1.000in - 1.240 DIA SS
10.9	2	32-6354	LIFTING SLING - .125in SS CABLE (2 @ 12 FT)
10.10	1	43-4194	KOR-N-SEAL - 34in X 30in IPS PIPE
10.11	1	43-5186	KOR-N-SEAL - 8in CORE - 1.70 THRU 4.80 PIPE
10.12	2	43-5193	KOR-N-SEAL - 16in CORE - 12in PIPE
10.13	6	47-5267	GASKET - FLANGE - 12in X 1/8in
10.14	1	48-XXXX	6" PVC PIPE - PERFORATED X 108in
10.15	163	51-5949	TAPECOAT - 6in X .65mils X LFT
10.16	174	51-6081	SEALANT - 1in X 1in X 14.5ft CS-202
10.17	1	51-ROM	NEVER SIEZE - TUBE
10.18	2	60-4574	FLOAT - NOLTA - MS1 - 20m
10.19	1	60-4896	PRESSURE TRANSDUCER - 4-20 ma - 5 PSI - CL1 DIV1 - 50ft CABLE
10.20	1	62-4561	BRACKET - TRANSDUCER - HANGING
11	1	18-XXXX	DISCHARGE PIPE BRACKET - 16in
12	2	30-5500	PUMP - EBARA - 300DLFU630 - 40HP
13	40	40-4128	PIPE - 304SS - 3in SCH10 (4@ 10 FT)
14	2	41-4173	VALVE - SWING CHECK - 12in - SG BUSTER
15	2	42-4767	SLEEVE - 12 IN - STAR - SOLID DI SHORT
16	4	42-5314	ROMAGRIP ACCESSORY PACK - 12in DI MJ
17	2	45-5319	SPOOL - FLG X PE - 12in X 30in - DI
18	2	45-5321	SPOOL - FLG X PE - 12in X 72in - DI
19	2	46-5266	ELBOW - DI - 12in - 90 DEG - FLG X FLG

NOTE: ALL DIMENSIONS AND ELEVATIONS SHOWN ARE NOMINAL DIMENSIONS. IT IS THE RESPONSIBILITY OF THE ON-SITE CONTRACTOR OR ROMTEC UTILITIES CUSTOMER (NOT ROMTEC UTILITIES) TO VERIFY THE ACCURACY OF ANY CRITICAL DIMENSIONS OR ELEVATIONS PRIOR TO SETTING OR INSTALLING ANY EQUIPMENT.

### 10' DIAMETER WET WELL 12" DISCHARGE PIPING 300DLFU630 EBARA PUMPS

ALL MATERIALS SHOWN ON THIS SHEET WILL BE SUPPLIED BY ROMTEC UTILITIES AND DELIVERED TO THE SITE AFTER THE HOLE HAS BEEN EXCAVATED AND SHORED. THE CONTRACTOR SHALL SUPPLY A CRANE OF SUFFICIENT SIZE TO LOWER ALL THE CONCRETE PIECES INTO THE HOLE SAFELY. THE CONTRACTOR SHALL INSTALL THE WET WELL (AND VALVE VAULT AND METERING VAULT IF APPLICABLE). ROMTEC UTILITIES WILL PROVIDE A REPRESENTATIVE FOR TECHNICAL ASSISTANCE ON THE DAY OF INSTALLATION TO ANSWER ANY QUESTIONS THAT MAY ARISE. THE CONTRACTOR IS RESPONSIBLE FOR ALL PLUMBING AND ELECTRICAL CONNECTIONS AND INSTALLATION. ITEMS NOTED AS "BY OTHERS" WILL BE PROVIDED AND INSTALLED BY THE CONTRACTOR. ROMTEC UTILITIES WILL NOT INSTALL ANY OF THE COMPONENTS SHOWN ON THIS PAGE.

© 2013 ROMTEC INC. ALL RIGHTS RESERVED. THESE PLANS AND DRAWINGS MAY NOT BE REPRODUCED, ADAPTED, OR FURTHER DISTRIBUTED, AND NO COMPONENTS MAY BE CONSTRUCTED FROM THESE PLANS, WITHOUT WRITTEN PERMISSION OF ROMTEC, INC.

VERIFY SCALE  
BAR IS ONE INCH ON ORIGINAL DRAWING  
1"  
IF NOT ONE INCH ON THIS SHEET, ADJUST SCALES PROPORTIONALLY

COMPONENT DRAWING

**ROMTEC UTILITIES**  
18240 NORTH BANK ROAD  
ROSEBURG, OREGON 97470  
(541) 496-9678  
FAX (541) 496-0804

INDIAN SPRINGS SW  
10' WET WELL - 12" DISCHARGE

SHEET  
**1 OF 1**  
JOB NUMBER  
**RMTC 0000**

REV	DESCRIPTION	DATE	APPROV
2	PER LAUNCH MEETING	2-26-14	N/A
1	PER COMMENT LOG	9-16-13	N/A

REVISION HISTORY



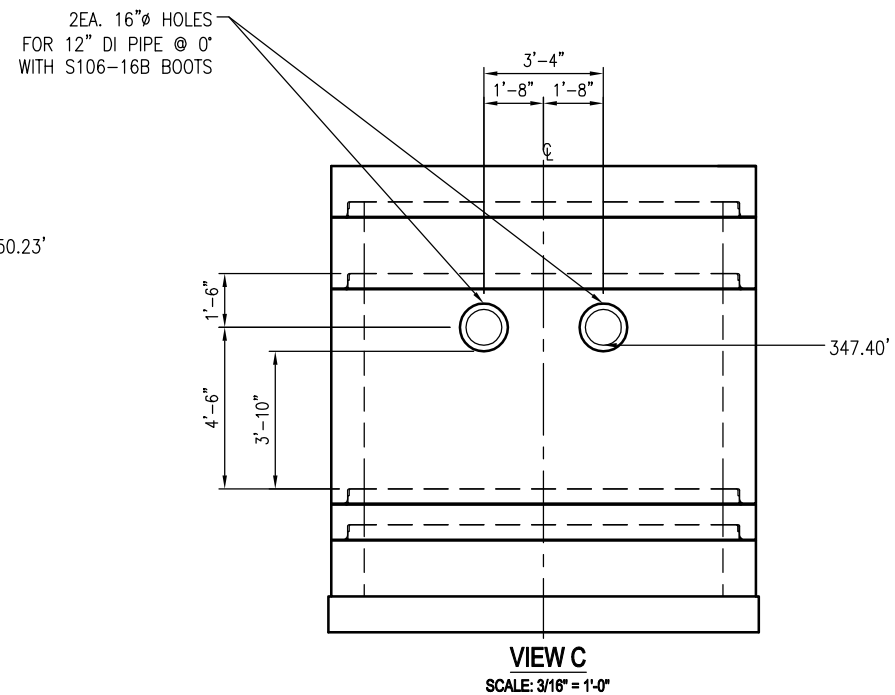
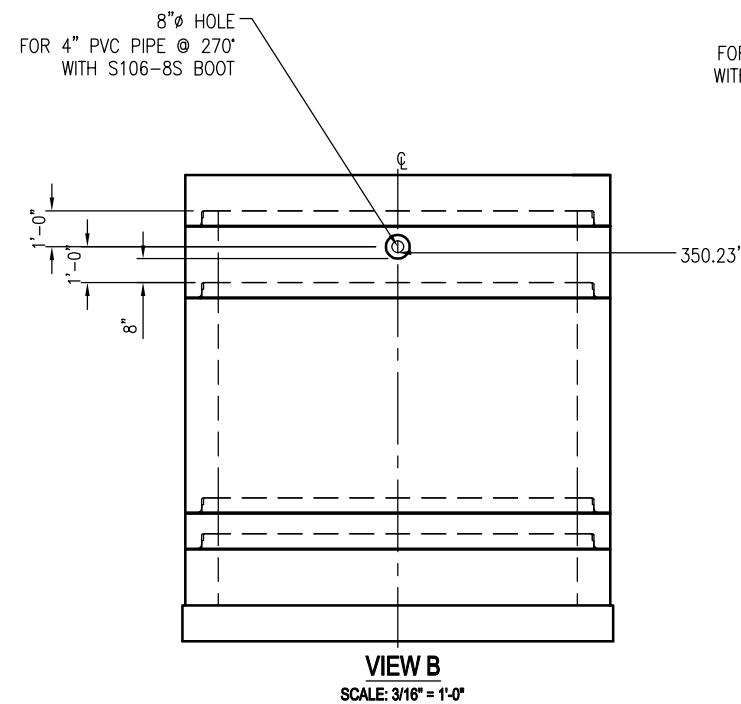
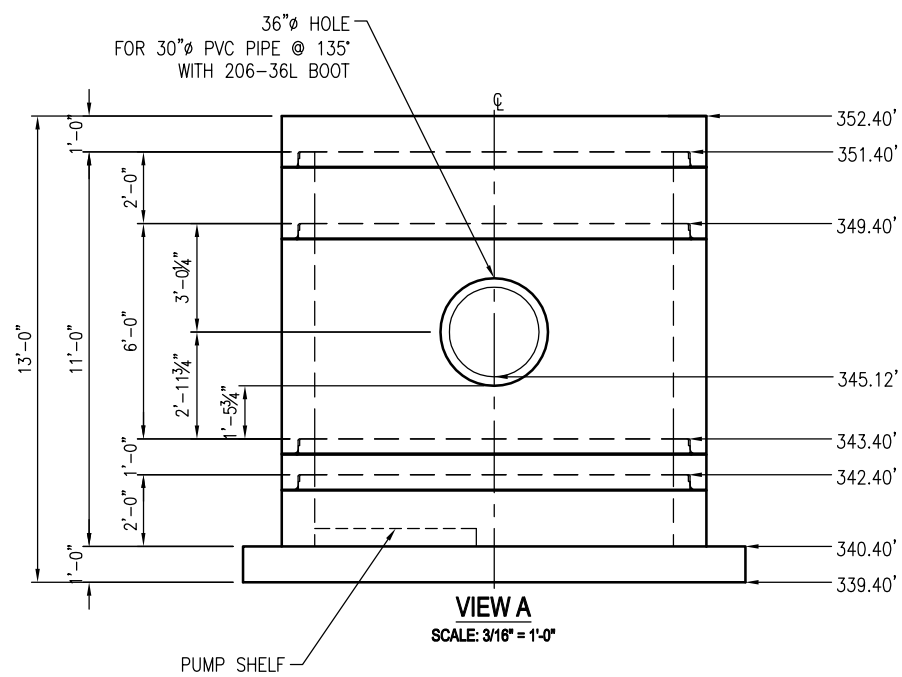
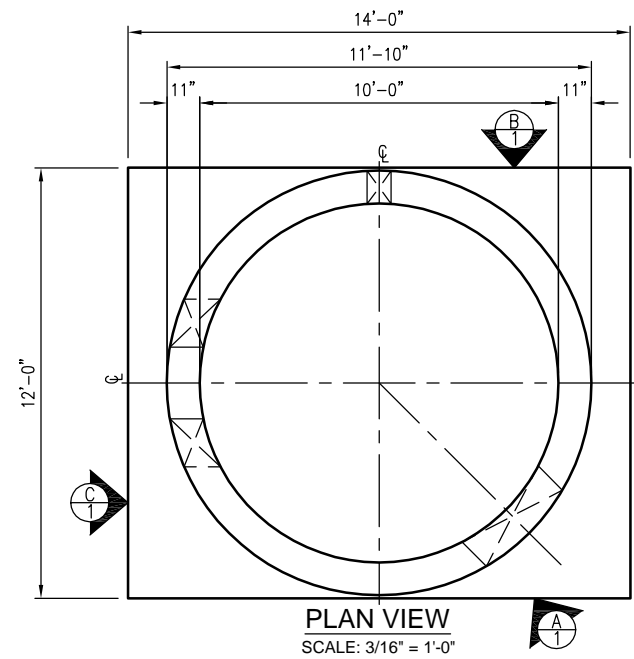

**STRUCTURAL NOTES:**

- LOADS:**
- H20 TRAFFIC
  - 150 PCF CONCRETE DENSITY; 120 PCF SOIL DENSITY
  - H20 SURCHARGE: 2 FT ABOVE FILL TO 8 FT BELOW GRADE
  - DRY SOIL LATERAL LOAD - 40 PCF
  - WET SOIL LATERAL LOAD - 80 PCF
  - WATER TABLE - BELOW VAULT

- DESIGN SPECIFICATIONS**
- ACI-318-11 BUILDING CODE
  - ASTM C 478 STANDARD SPECIFICATIONS FOR REINFORCED CONCRETE MANHOLE SECTIONS

- MATERIALS:**
- CONCRETE - 28 DAY COMPRESSIVE STRENGTH  $f_c = 6000$  PSI
  - REBAR - ASTM A 706 GRADE 60
  - CEMENT - ASTM C150
  - FLYASH - ASTM C618

- GENERAL NOTES:**
- 1) CONTRACTOR TO: VERIFY ALL DIMENSIONS AND OPENING LOCATIONS
  - 2) REBAR MAY BE TACK WELDED OR TIED
  - 3) TOLERANCES PER ASTM C 478 STANDARD SPECIFICATIONS FOR REINFORCED CONCRETE MANHOLE SECTIONS



THIS DOCUMENT IS THE PROPERTY OF OLDCASTLE PRECAST, INC. IT IS SUBMITTED FOR REFERENCE PURPOSES ONLY AND SHALL NOT BE USED IN ANY WAY INJURIOUS TO THE INTERESTS OF SAID COMPANY.

COPYRIGHT © 2013 OLDCASTLE PRECAST, INC. ALL RIGHTS RESERVED.

**10'Ø X 11'-0" (I.D.) WET WELL**

INDIAN SPRINGS SW  
STOCKTON, CA

CUSTOMER  
**ROMTEC**

DATE	SALES	DRAWN	ENGINEER	CHECKED	SALES ORDER
9/17/13	BD	VK	JM	JM	S18973
DRAWING NUMBER				REVISION	SHEET
030-S18973-089				1	1 OF 1
				REV DATE	
				09/17/13	

Revision	Description	BY	DATE
-	-	-	-

ASTM GRADE 60 STEEL REBAR

ITEM NO.	BAR SIZE	BAR LENGTH	QTY.	TOTAL LENGTH	TOTAL WEIGHT	
1	#5	4'-5"	1	4'-5"	4.6#	
2	#5	7'-0"	2	14'-0"	14.6#	
TOP 2 & BOTTOM 1	3	#5	8'-7"	3	25'-9"	26.9#
4	#5	9'-8"	1	9'-8"	10.1#	
TOP 1 & BOTTOM 1	5	#5	10'-3"	2	20'-6"	21.4#
6	#5	10'-8"	1	10'-8"	11.1#	
7	#5	11'-1"	1	11'-1"	11.6#	
8	#5	1'-11"	4	7'-8"	8.0#	
9	#5	2'-0"	4	8'-0"	8.3#	
TOP 4 & BOTTOM 4	10	#5	1'-9"	8	14'-0"	14.6#
TOP 4 & BOTTOM 2	11	#5	1'-6"	6	9'-0"	9.4#
12	#5	9'-10"	1	9'-10"	10.3#	
13	#5	9'-1"	1	9'-1"	9.5#	
14	#5	8'-3"	1	8'-3"	8.6#	
15	#5	4'-11"	1	4'-11"	5.1#	
16	#5	4'-1"	3	12'-3"	12.8#	
17	#5	4'-0"	2	8'-0"	8.3#	
TOP 2 & BOTTOM 6	18	#5	3'-10"	8	30'-8"	32.0#
TOP 2 & BOTTOM 2	19	#5	3'-6"	4	14'-0"	14.6#
20	#5	3'-2"	2	6'-4"	6.6#	
21	#5	8'-9"	2	17'-6"	18.3#	
22	#5	7'-9"	2	15'-6"	16.2#	
23	#5	6'-6"	2	13'-0"	13.6#	
24	#5	4'-8"	2	9'-4"	9.7#	
TOP 2 & BOTTOM 2	25	#5	2'-2"	4	8'-8"	9.0#
26	#5	2'-5"	2	4'-10"	5.0#	
TOP 1 & BOTTOM 2	27	#5	2'-7"	3	7'-9"	8.1#
28	#5	2'-8"	3	8'-0"	8.3#	
TOP ONLY	29	#5	6'-0"	1	6'-0"	6.3#
30	#5	8'-0"	2	16'-0"	16.7#	
31	#5	9'-4"	2	18'-8"	19.5#	
32	#5	10'-11"	1	10'-11"	11.4#	
33	#5	1'-10"	6	11'-0"	11.5#	
34	#5	1'-3"	2	2'-6"	2.6#	
35	#5	6'-2"	1	6'-2"	6.4#	
36	#5	3'-9"	2	7'-6"	7.8#	
37	#5	3'-4"	2	6'-8"	7.0#	
38	#5	2'-11"	2	5'-10"	6.1#	
39	#5	6'-10"	2	13'-8"	14.3#	
40	#5	4'-1"	4	16'-4"	17.0#	
41	#5	2'-4"	4	9'-4"	9.7#	
TOTAL			107	453'-3"	472.7#	
42	MESH 2x8-d5xw2,5	12" HIGH 37'-2" LONG, CIRCLE D=11'-6"				

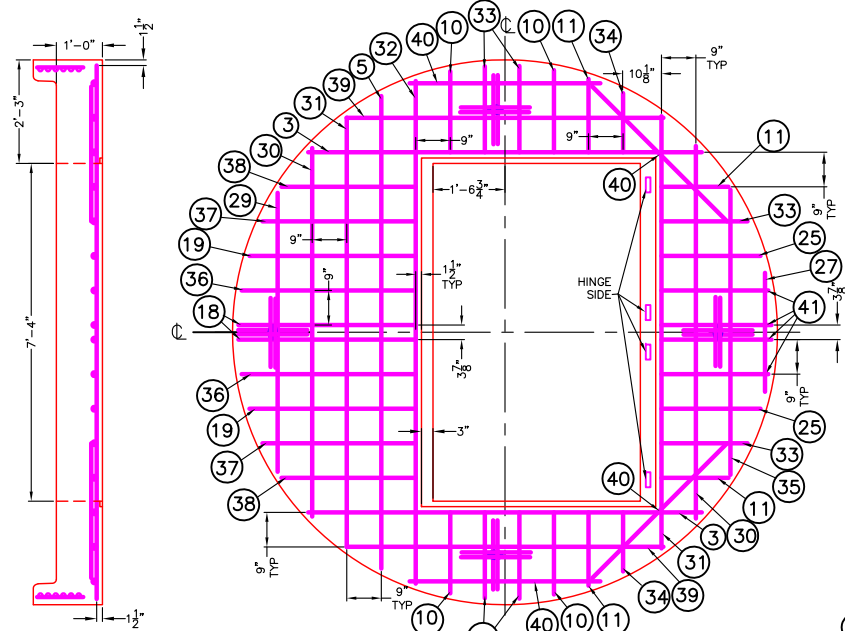

TOP REBAR DETAILS

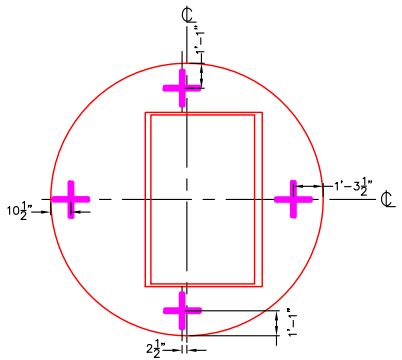

ANCHOR POSITION

4 LIFTING INSERTS SEE NOTE  
EACH INSERT WITH 4 #4 REBAR.  
LENGTH 18" FOR ANCHORING TO  
CONCRETE

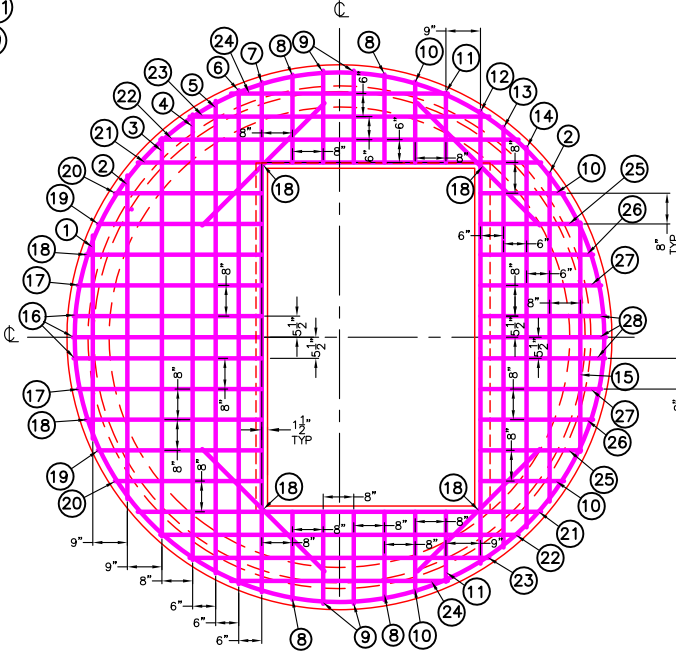
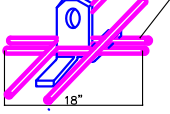

BOTTOM REBAR DETAILS

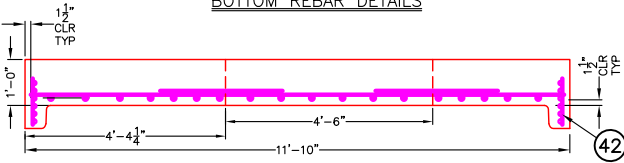

NOTE: CONAC LIFTING ANCHOR FFA0806.3 8 TON LOAD CAPACITY WITH REBAR'S REINFORCEMENT.

CONCRETE QUANTITY = 3.04 C.Y. HATCH W = 1000#

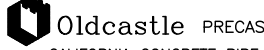

CALIFORNIA CONCRETE PIPE 2960 S. HIGHWAY 99 (209) 466-4212  
STOCKTON, CA. 95215 FAX: (209) 466-2552

120" DIA. REINFORCED MH FLAT TOP FOR ROMTEC UTILITIES  
"HATCH ASGD-54X88(53X88)". 300#/.S.F. LOAD ONLY  
CONFORMS TO: ASTM C478. DWG. NO: 54788

THIS DOCUMENT IS THE PROPERTY OF CALIFORNIA CONCRETE PIPE. IT IS SUBMITTED FOR REFERENCE PURPOSES ONLY AND SHALL NOT BE USED IN ANY WAY INJURIOUS TO THE INTERESTS OF SAID COMPANY.	DRAWN OLG	DATE 7/31/09	WT. 14600#	DRAWING NO.
	REVISED ---	---	REVISION NO. ---	09-ROM-120FT-PD-DX
			SCALE	SHEET 1 OF 1

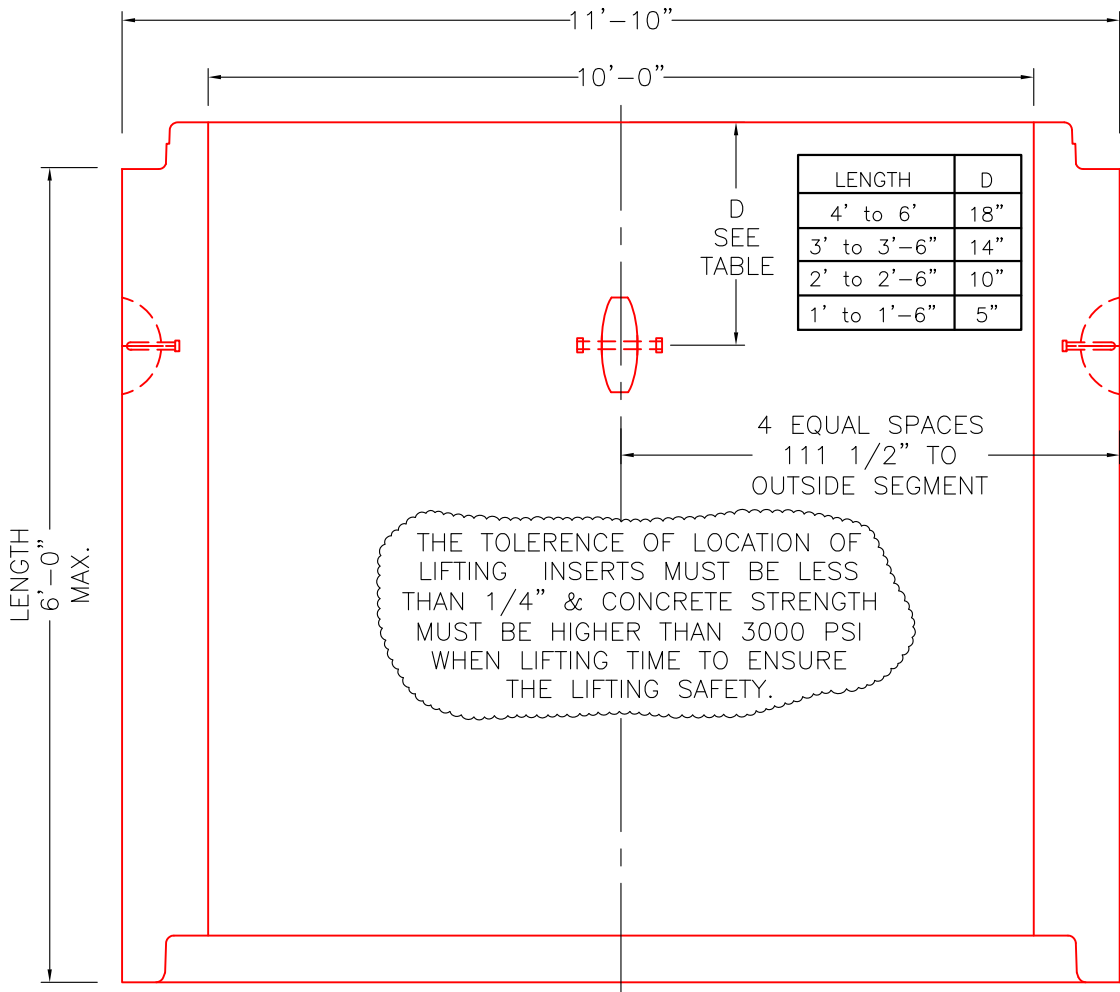

7.	CHANGED TITLE, JOINT, MAX.LENGTH & HOOKS LOCATION	QLG	6/2/08
6.	CHANGED BACK TO CAGE GAP SPEC.	QLG	8/23/07
5.	CHANGED CAGE LAP, ADDED LIFTING INSERTS & SPEC.	QLG	7/30/07
4.	CHANGED INNER & OUTER CAGES TO 3x9-d4.0xw2.0	QLG	7/20/07
3.	TURNUED RISER UP SIDE DOWN & ADDED 5" FOR JOINT	QLG	2/27/07
2.	THICKER LINE FOR REBAR & CHANGED APPROVE STAMP	QLG	6/1/04
1.	ADDED CONCRETE VOLUME	QLG	7/18/03
0.	RELEASED FOR APPROVAL	RAS	6/5/01
	Revision Description	BY	DATE

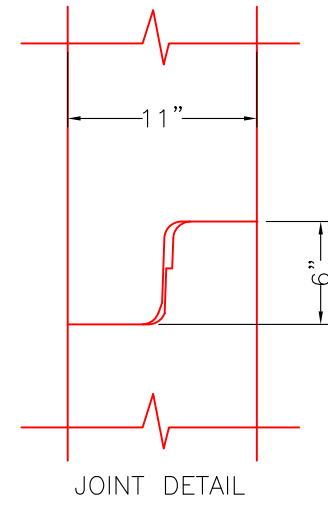

NOTE: (1) CONAC 8CA18 FOR ORDINARY CUSTOMER.  
 (2) CONAC FFA 0806 FOR ROMTEC UTILITIES.  
 WITH 4 #4 LENGTH 18" REBARS.

CONCRETE VOLUME = 1.17 C.Y./Ft.  
 6' TOTAL = 7.02 C.Y. WEIGHT = 28900#

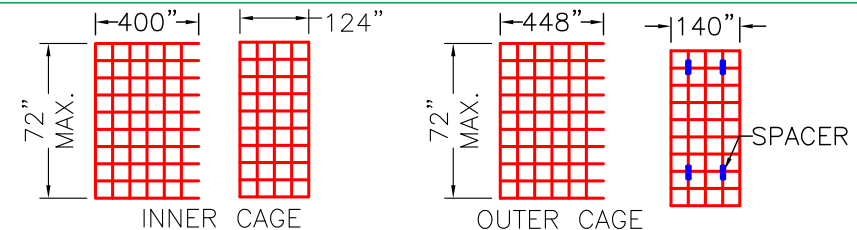
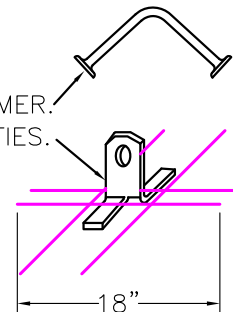

outer	3x8-d4.0xw2.0	56	0"			4000
inner	3x8-d4.0xw2.0	50	2 1/2" OVER	A9.0	38	
CAGE	MESH	SPACES	GAP	SPACER	QTY.	CON. STRENGTH (psi)

## Oldcastle PRECAST

CALIFORNIA CONCRETE PIPE    2960 S. HIGHWAY 99    (209) 466-4212  
 STOCKTON, CA. 95215    FAX: (209) 466-2552

120" DIA. REINFORCED MANHOLE RISER  
 11" WALL , UP TO 72" LONG  
 CONFORMS TO: ASTM C478

THIS DOCUMENT IS THE PROPERTY OF CALIFORNIA CONCRETE PIPE. IT IS SUBMITTED FOR REFERENCE PURPOSES ONLY AND SHALL NOT BE USED IN ANY WAY INJURIOUS TO THE INTERESTS OF SAID COMPANY.	DRAWN	RAS	DATE	6/5/01	WT.	4808#/ft	DRAWING NO.
	REVISED	QLG	DATE	6/2/08	REVISION NO.	7	MH-120
					SCALE	NO SCALE	SHEET 1 OF 1

**BOTTOM LAYER REBARS**

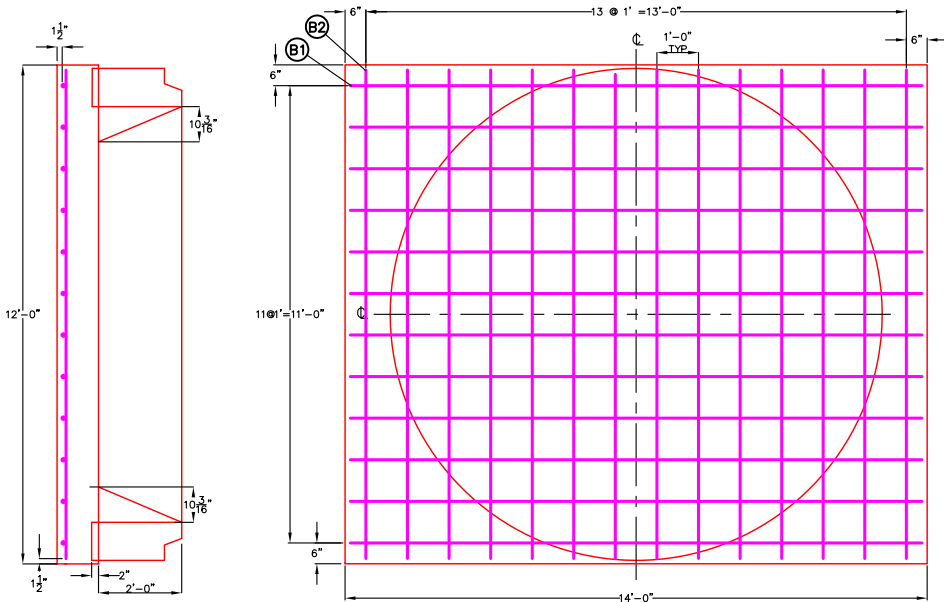

TOLERANCE FOR TOP LAYER REBAR LOCATION MUST BE CONTROLLED 1/4"

**TOP LAYER REBARS**

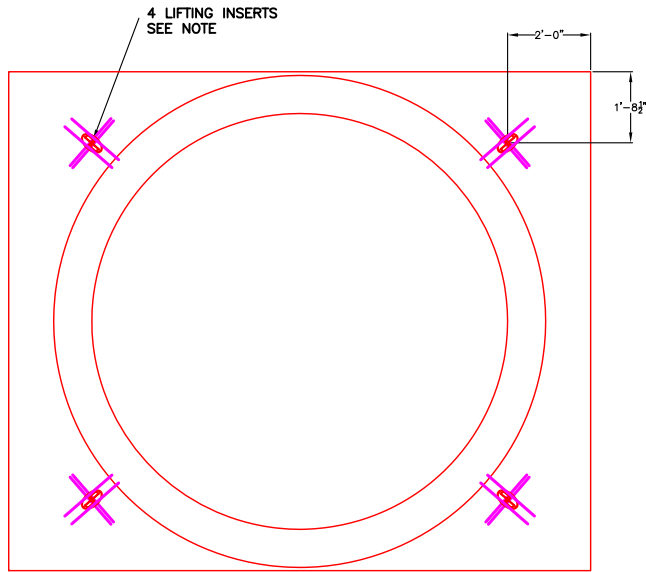
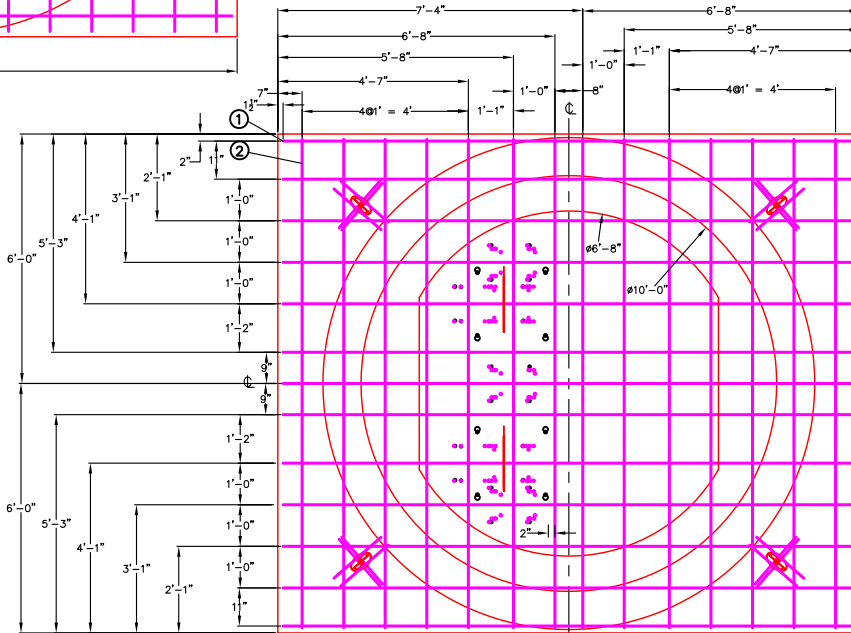

**LIFTING INSERTS LOCATION**

**ASTM GRADE 60 STEEL REBAR**

TOP LAYER REBARS ALL #6					
ITEM NO.	BAR SIZE	BAR LENGTH	QTY.	TOTAL LENGTH	TOTAL WEIGHT
1	#6	13'-9"	13	178'-9"	268.5#
2	#6	11'-9"	14	164'-6"	247.1#
<b>TOTAL</b>			<b>27</b>	<b>243'-3"</b>	<b>515.6#</b>

BOTTOM LAYER REBARS ALL #5					
ITEM NO.	BAR SIZE	BAR LENGTH	QTY.	TOTAL LENGTH	TOTAL WEIGHT
B1	#5	13'-9"	12	165'-0"	172.1#
B2	#5	11'-9"	14	164'-6"	171.6#
<b>TOTAL</b>			<b>26</b>	<b>329'-6"</b>	<b>343.7#</b>

NOTE: 8 TON CONAC FFA ANCHOR FFA 08063 WITH REBARS EACH LIFTING INSERT MUST BE ALLOWABLE TENSION LOAD CAPACITY OVER 12000 lbs.

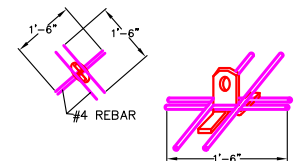

BASE SLAB CONCRETE 6.3 C.Y.  
TOP OF SLAB CONCRETE 1.0 C.Y.  
(RISER 2.40 C.Y. CASTED EARLY)  
TOTAL 9.7 C.Y.

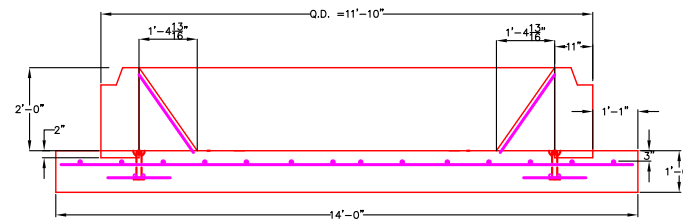

**Oldcastle PRECAST**  
CALIFORNIA CONCRETE PIPE 2900 S. HIGHWAY 99 (209) 466-4212  
ROCKFORD, CA 95215-8047 FAX: (209) 466-2552

120" DIA. REINFORCED BASE SLAB FOR MAXIMUM 20' DEEP WET WELL, 11" WALL FOR ROMTEC UTILITIES  
CONFORMS TO: ASTM C478

DESIGN	DATE	ISSUE	SCALE
REVISED	1/17/08	NO. 390008	AS-BUILT
REVISION NO.		28-ROMTCC-120BASE	
		SCALE NO SCALE	SHEET 1 OF 1

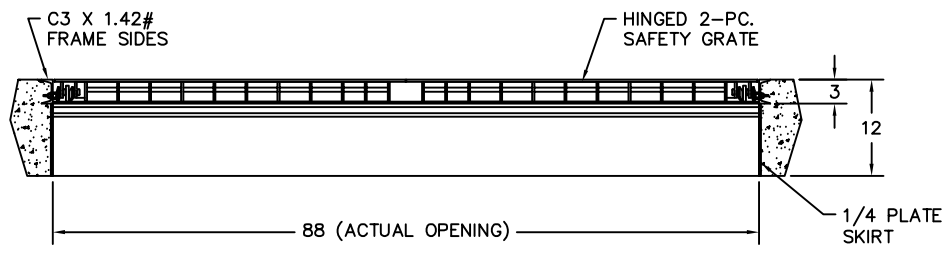
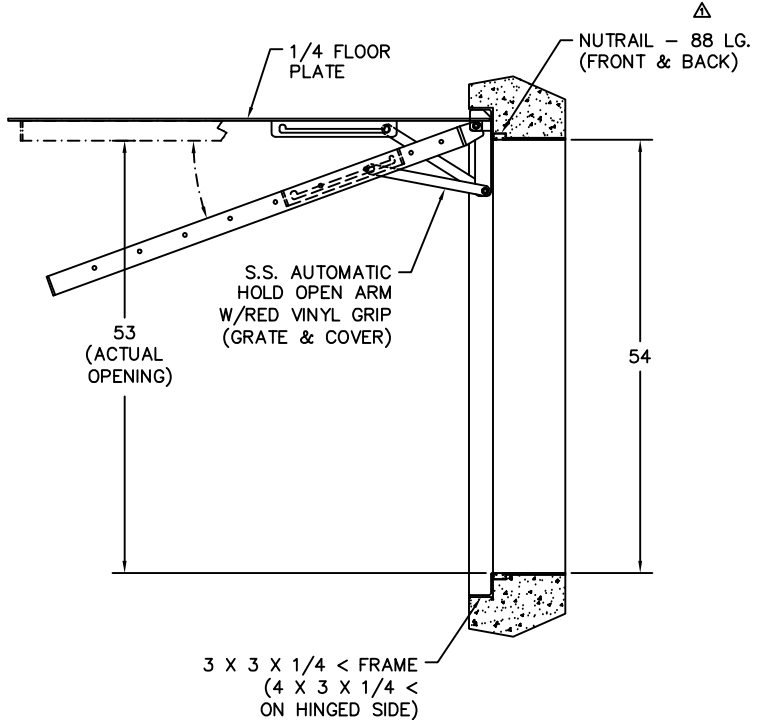
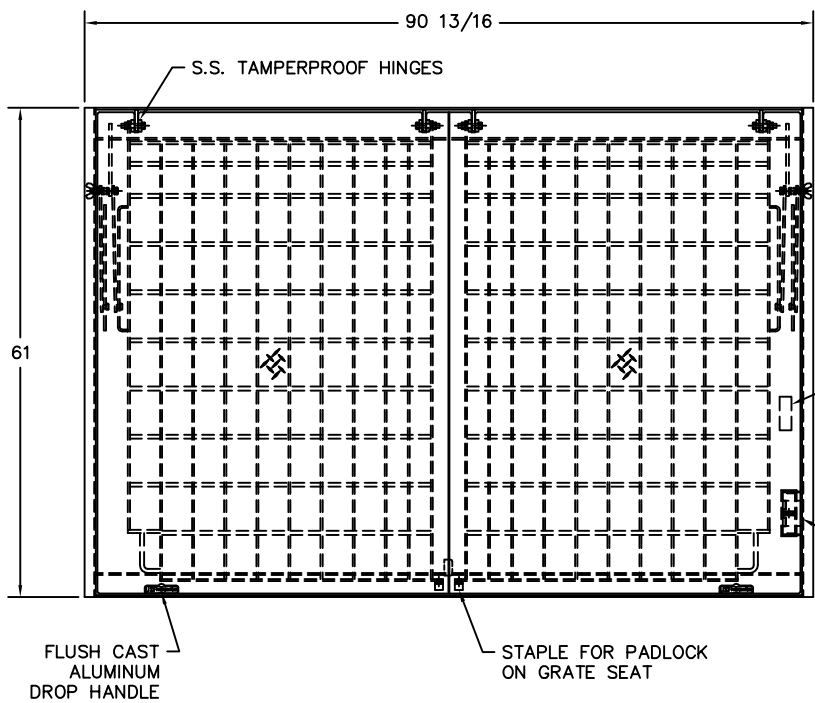

- NOTES:**
- 1- MATERIAL: ALUMINUM
  - 2- LOADING: 300 LBS. PER SQ. FT.
  - 3- 316 STAINLESS STEEL NUTS & BOLTS
  - 4- AREA OF FRAME IN CONTACT WITH CONCRETE TO BE PAINTED WITH BITUMINOUS COATING
  - 5- SAFETY GRATE TO BE PAINTED WITH SAFETY ORANGE POWDER COAT

ROMTEC 10 FT. DIA. WET WELL

COPYRIGHT © 2011  
 ALL RIGHTS RESERVED  
 THIS DRAWING IS THE SOLE PROPERTY OF  
**U.S.F. FABRICATION INC.**  
 HIALEAH, FLORIDA

HATCH ASGD 54 X 88 ALUMINUM  
 (53 X 88 ACTUAL OPENING)  
 HINGED ON THE SAME SIDE WITH RECESSED  
 PADLOCK, NUTRIL, SKIRT & BITUMINOUS PAINT

△	6/29/11	DAV	88 LG. NUTRIL WAS 16 LG. (BACK SIDE)
REV.	DATE	BY	CHK.
			DESCRIPTION

PUBLICATION AND DISTRIBUTION IN WHOLE OR IN PART IS PROHIBITED WITHOUT PRIOR WRITTEN CONSENT

OWN. BY: DAV	SCALE: 1=12	QUOTE#	DATE: 9/10/08
CHK. BY:	DWG. NO: 54788	SHEET 1 of 1	REV: △

**STRUCTURAL DESIGN AND WET WELL WEIGHTS**

All Romtec Utilities concrete wet well pre-cast components conform to ASTM C 478. Wet Well components are pre-cast with 4,000 psi. concrete and 60,000 psi. steel.

**Romtec Utilities has not done any site specific structural calculations for this project. Romtec Utilities has not done any site specific up-lift calculations for this project. General uplift calculations for fully saturated soil have been completed and are available upon request.**

**LIFTING ANCHORS PROVIDED BY ROMTEC UTILITIES**

Wet Well concrete components are equipped with Conac lifting system anchors and ring clutches. Wet Well 120" diameter manhole base slab is pre-cast with four (4) Conac Flat Foot Anchors (Model F FA 08 063 – Eight (8) ton anchor) located in the extended base. Wet Well 120" diameter manhole riser is pre-cast with four (4) Conac Flat Foot Anchors (Model F FA 04 038 – Four (4) ton anchor) located on the outside of the barrel. Wet Well 120" diameter top slab is pre-cast with Four (4) Conac Flat Anchors (Model F FA 04 038 – Four (4) ton anchor) located on the top.

**FLAT FOOT ANCHOR**

*Ideal for back stripping or lifting thin precast panels.*

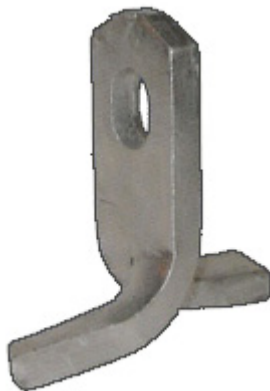

<i>Ton</i>	<i>Part Number</i>	<i>Length</i>	<i>Thickness</i>	<i>Allowable Reinforced Tension Load S.F. 4:1 (lbs)</i>	<i>Ultimate Mech. Load Tension * (lbs)</i>	<i>System Code</i>
2	F FA 02 028A	2.8"	3/16"	2,000	8,000	2.5
2	F FA 02 034A	3.4"	3/16"	2,000	8,000	2.5
2	F FA 02 028B	2.8"	3/8"	4,000	16,000	2.5
2	F FA 02 034B	3.4"	3/8"	4,000	16,000	2.5
4	F FA 04 038	3.8"	1/2"	6,000	24,000	5
8	F FA 08 063	6.3"	5/8"	12,000	48,000	10

**LIFTING RING CLUTCHES PROVIDED BY ROMTEC UTILITIES**

Wet Well concrete components are designed to be lifted with the Romtec Utilities provided Conac lifting clutches. Romtec Utilities will provide eight (8) Conac Ring Clutches (Model F RC 08 B – Eight (8) ton anchors).

**RING CLUTCH**

Designed to be used specifically for flat steel lifting. Handle allows for a safer locking of clutch into position.



<i>Ton</i>	<i>Item No.</i>	<i>Weight lbs</i>	<i>System Code</i>
2T	F RC 02 B	4.0	2.5T
4T	F RC 04 B	9.0	5.0T
<b>8T</b>	<b>F RC 08 B</b>	<b>20.0</b>	<b>10.0T</b>
22T	F RC 22 B	56.0	22.0T



**ROMTEC UTILITIES RECOMMENDED WET WELL LIFTING METHOD**

All wet well concrete components are designed to be lifted and set in the excavated hole by use of the Romtec Utilities supplied anchors and ring clutches. The installation contractor shall excavate the wet well hole, place the base rock as specified by the **SITE ENGINEER (not Romtec Utilities)**, provide a **safe OSHA approved cave-in protection method (shoring) and a crane of adequate size to lift and set the heaviest piece**. The excavation contractor and/or his subcontractor crane company must provide the appropriate lifting cables, straps or chains and connection devices to attach the cables to the crane and the ring clutches. All lifting cables, straps or chains must be long enough that when lifting the concrete components the lifting rigging does not put pressure on the upper concrete joint potentially breaking the concrete. **The use of a spreader bar will greatly reduce the risk of the lifting rigging breaking the concrete upper joint.**

**WET WELL CONCRETE COMPONENT WEIGHTS:**

ITEM	SIZE	WEIGHT
120" Manhole Base	11'-10" X 11'-10" Outside Dimension	44,000 lbs.
120" Manhole Riser	11'-10" Outside Diameter	4,700 lbs. Per Foot
120" Manhole Top Slab	11'-10" Outside Diameter	14,000 lbs.





**8.05****WET WELL TESTING FOR WATER INGRESS OR  
EGRESS**

**Romtec Utilities wet wells are water tight. If testing is required, then the testing is to be performed as follows.**

**Romtec Utilities recommends performing the testing prior to backfilling. This helps with identifying any leakage and locating the area of leakage.**

**If the testing is performed after backfilling, Romtec Utilities is not responsible for any excavation than has to be done to fix any leaks.**

The recommended test methods are per ASTM C497-05 Section 8. Hydrostatic Test Method or Section 9. Permeability Test Method.

**8. Hydrostatic Test Method****8.1 Summary of Test Method**

The section of pipe or manhole is subjected to hydrostatic pressure and observed for leakage at the joint or on the surface of the wall. The joint is defined as a connection between the concrete section of pipe or manhole that provides alignment and the flexible watertight seal using either, rubber gaskets, sealing bands, or preformed flexible joint sealant.

**8.2 Significance and Use**

The test method is a quality control test performed to establish the fact that the finished, shippable pipe or manhole meets the hydrostatic requirements stated in the specifications for the installed wall or joint, or both.

**8.3 Procedure:**

8.3.1 The equipment for making the test shall be such that, when the specimen under test is filled with water to the exclusion of air and subject to the required hydrostatic pressure, there shall not be enough leakage of water from the ends of the pipe to interfere with the test. The specimen under test shall be free of all visible moisture prior to the initiation of the test.

## 8.05

# WET WELL TESTING FOR WATER INGRESS OR EGRESS

8.3.2 Do not test when the temperature of the specimen, the air around the specimen, or the water within the specimen is below 33°F.

8.3.3 If the joint seal and/or flexible connector are being tested, it shall be the sole element providing joint water tightness. No mortar or concrete coatings, fillings, or packing shall be used prior to the test.

Once the wet well is stacked in the proper sequence, fill the well to the highest operation point in the well or the ground water elevation, whichever is the highest. There shall be no visible leakage. Moisture appearing in the form of patches or beads adhering to the surface shall not be considered leakage. If leakage occurs, the manufacturer is not prohibited from extending the soak time to 24 hour.

## 9. Permeability Test Method

### 9.1 Summary of Test Method

A section of pipe is kept filled with water for specified time and the outer surface is tested for moisture.

### 9.2 Significance and Use

The test method is a quality control test performed to establish the fact that the finished, shippable pipe meets the leakage limits stated in the specifications.

### 9.3 Procedure

The pipe specimen under test shall be free of all visible moisture prior to the initiation of the test. Perform tests by placing the specimen to be tested, with the spigot end down on a soft rubber mat or its equivalent, weighted if necessary, and kept filled with water to a level of the base of the socket during the test period. Make the initial inspection approximately 15 min after the test has begun. If the pipe shows moist or damp spots on the outer surface of the pipe at that

## 8.05

### WET WELL TESTING FOR WATER INGRESS OR EGRESS

time, continue the tests for period not to exceed 24 h. at the option of the manufacturer. Examine the pipe during the extended period for existence of moist or damp spots.

Prior to either test all inlets and outlets must be plugged.

#### **Repairs**

Repair of manhole products shall not be prohibited, if necessary, because of imperfections in manufacture or damage during handling. The repair will be acceptable if, the repaired products conform to the requirements of the ASTM C478-09 specification. Romtec Utilities must be notified if any repairs are necessary.

In other words

If the wet well has any areas of leakage the contractor must report this leakage to Romtec Utilities and then together the contractor and Romtec Utilities will come up with a fix. In the unlikely event of a wet well leaking, this does not warrant a complete replacement. A reasonable effort must be given to fix the leak.

PAGE IS INTENTIONALLY LEFT BLANK

Say *Goodbye* to the lube bucket and brush .....  
 Say *Hello* to fast, clean, simple installation

*Requiring no field lubrication*, the Tylox<sup>®</sup> SuperSeal<sup>™</sup> gasket\* has a layer of silicone lubricant installed on the inner surface of the tube during the manufacturing process; saving you time, and money, on the job-site.

*Self-contained Lubricant.* Sealed within the tube, the lube is impervious to mud, dirt and debris. If you drop it in the trench, simply wipe the gasket surface clean and you're ready to install. No special handling or packaging is required.

*Easier installation, without equalization*, is made possible due to the reduced gasket stretch required by the unique lamell/rolling tube design. Quick and easy to install means you save even more time.

*No gasket "roll" or "twist" during coupling* is another benefit of the unique lamell/rolling tube design, which reduces the insertion force required. Manual coupling of up to 36" pipe is possible.

## For Single Offset Joints ...

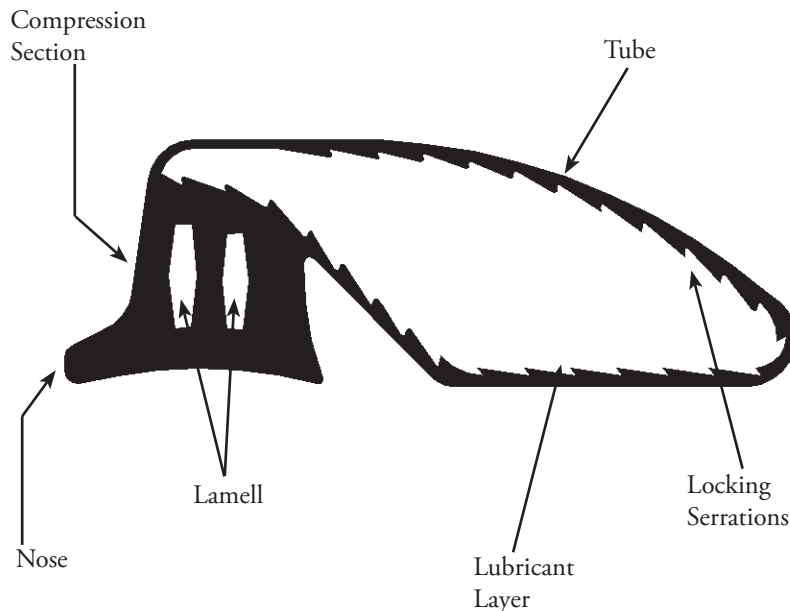

**... in Round or Elliptical Pipe, Man-Holes and Boxes**

*Self-Centering of the Spigot within the Bell* is carried out as the tube rolls into the annular space during the homing process.

*Elimination of Joint Kick Back*, is caused by the rearward locking action of the serrations as the tube rolls forward

*Bell and Spigot protection under deflection* is accomplished by the cushioning effect of the tube, as it rests within the annular space.

*ASTM C361, ASTM C425, ASTM C443, AASHTO M198.4 and CSA A-257* material requirement compliance.

*Pipe sizes to 144"* can be accommodated.

## INSTALLATION

Ensure Bell, Spigot and Gasket are free from loose debris or foreign material.

Stretch the gasket around the spigot, with the nose against the step, and the tube laying flat against the spigot. **DO NOT LUBRICATE.**

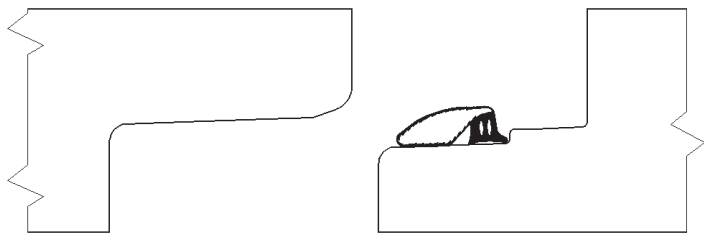

Align the spigot with the bell, and thrust the spigot home using suitable mechanical means. The homing process will cause the lubricated tube to “roll” over itself, above the compression section, allowing the pipe to slide forward.

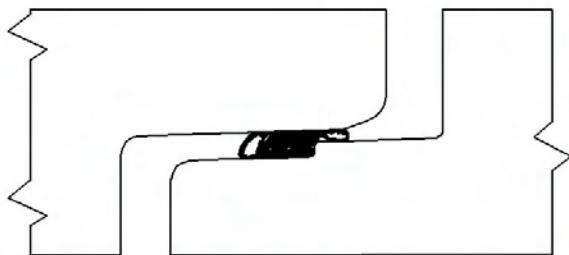

Once fully homed, the compression section seals the total annular space; the rolling tube comes to rest within the small annular space - acting as a cushion against side loads, and the serrations act to resist pipe pull-out.

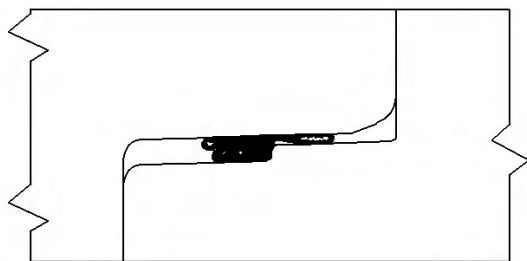

\*Tylox SuperSeal Gaskets are patented under US Patent 4934716

## MATERIALS

Tylox® SuperSeal™ gaskets\* are available in the following materials:

- Isoprene

Optional Materials

- Nitrile (Oil Resistant)
- Isoprene / EPDM blend (Green Book & C425)
- Neoprene (Oil and Ozone Resistant)

Other materials may be available as special order.

Consult your Hamilton Kent agent for your specific requirements.

## SPECIFICATIONS

Tylox® SuperSeal™ gaskets\* are manufactured to meet the material requirements of the following specifications:

- ASTM C361, C425, & C443
- AASHTO M198.4
- CSA A257
- “Green Book”

Other specifications may be available as special order. Please consult your Hamilton Kent agent for your specific requirements.

## CONTACT US

### Hamilton Kent

77, Carlingview Drive  
Toronto, Ontario, Canada.  
M9W 5J6

Phone (800) 268-8479  
Fax (888) 674-6960

Web-Site [www.hamiltonkent.com](http://www.hamiltonkent.com)  
E-Mail [sales@hamiltonkent.com](mailto:sales@hamiltonkent.com)

All Tylox® SuperSeal™ gaskets are warranted for 12 months from date of purchase (Invoice Date) in accordance with the details as outlined in Hamilton Kent's Standard Terms and Conditions of Sale.

Lit\_TSS\_0601\_ER4

**NO  
LUBRICANT  
REQUIRED**

**TYLOX  
SuperSeal**

**HK Hamilton Kent**  
*make the connection*

**Pipe & Manhole Pre-lubricated Gasket Installation**

**Pipe**

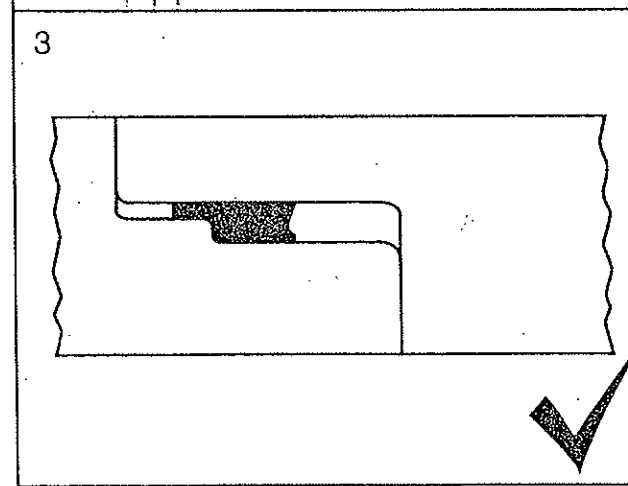
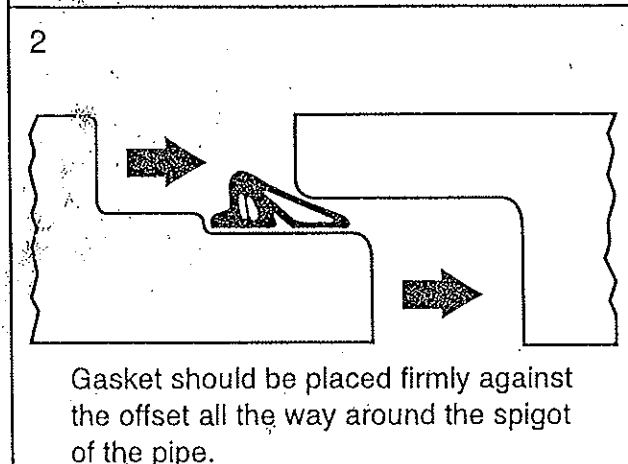
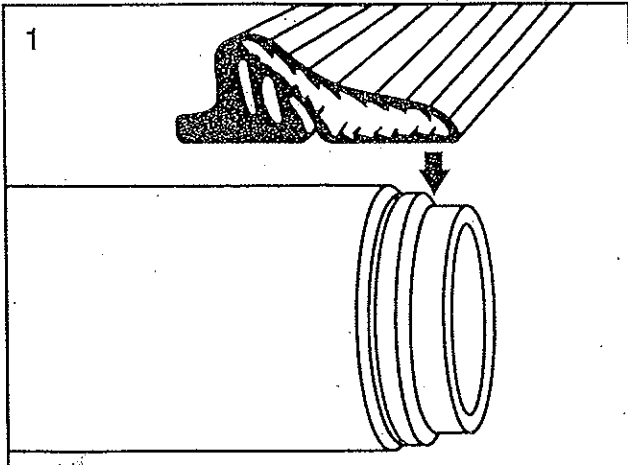

**Manhole**

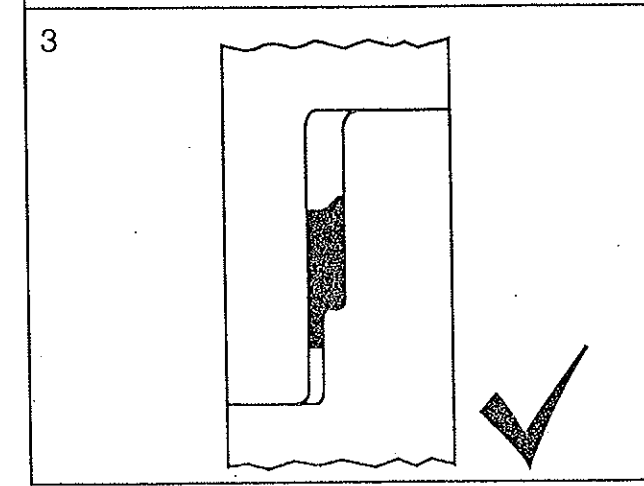
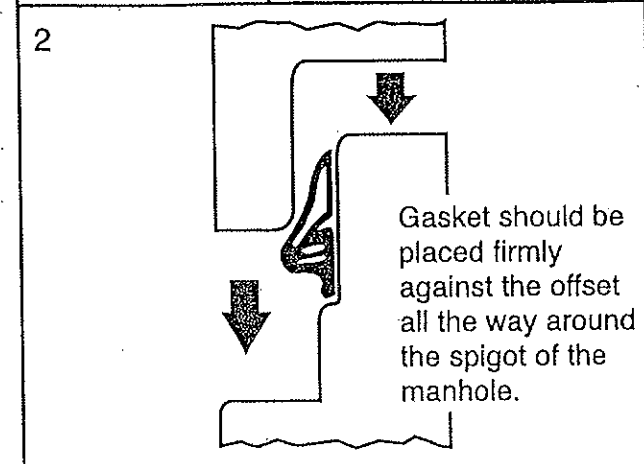
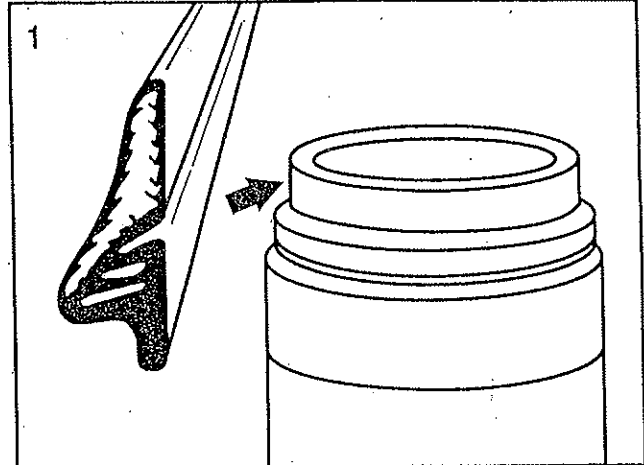

**CONSEAL™**  
Concrete Sealants INC.**CS-202**

Butyl Rubber Sealant

## APPLICATIONS

For self-sealing joints in: Manholes, Concrete Vaults, Septic Tanks, Concrete Pipe, Box Culverts, Utility Vaults, Burial Vaults, and Vertical Panel Structures.

## SEALING PROPERTIES

- Provides permanently flexible watertight joints.
- Low to high temperature workability: 0°F to 120°F (-12°C to 48°C)
- Rugged service temperature: -30°F to +200°F (-34°C to +93°C)
- Excellent chemical and mechanical adhesion to clean, dry surfaces.
- Sealed Joints will not shrink, harden or oxide upon aging.
- No priming normally necessary. When confronted with difficult installation conditions, such as wet concrete or temperatures below 40°F (4°C), priming the concrete will improve the bonding action. Consult Concrete Sealants for the proper primer to meet your application.

## HYDROSTATIC STRENGTH

ConSeal CS-202 meets the hydrostatic performance requirement as set forth in ASTM C-990 section 10.1 (Performance requirement: 10psi for 10 minutes in straight alignment – in plant, quality control test for joint materials.)

## SPECIFICATIONS

ConSeal CS-202 meets or exceeds the requirements of Federal Specification SS-S-210 (210-A), AASHTO M-198B, and ASTM C-990-91.





**CONSEAL™**  
Concrete Sealants INC.

**CS-202**

Butyl Rubber Sealant

**PHYSICAL PROPERTIES**

	<b>Spec</b>	<b>Required*</b>	<b>CS-202</b>
Hydrocarbon blend content % by weight	ASTM D4 (mod.)	50% min.	52%
Inert mineral filler % by weight	AASHTO T111	30% min.	35%
Volatile Matter % by weight	ASTM D6	2% max.	1.2
Specific Gravity, 77°F	ASTM D71	1.15-1.50	1.20
Ductility, 77°F	ASTM D113	5.0 min.	12
Penetration, cone 77°F, 150 gm. 5 sec.	ASTM D217	50-100	60-65
Penetration, cone 32°F, 150 gm. 5 sec.	ASTM D217	40 mm	50-55
Flash Point, C.O.C., °F	ASTM D92	350°F min.	425°F
Fire point, C.O.C., °F	ASTM D92	375°F min.	450°F

**IMMERSION TESTING**

- 30-Day Immersion Testing: No visible deterioration when tested in 5% Caustic Potash, 5% Hydrochloric Acid, 5% Sulfuric Acid, and 5% saturated Hydrogen Sulfide. \*
- One Year Immersion Testing: No visible deterioration when tested in 5% Formaldehyde, 5% Formic Acid, 5% Sulfuric Acid, 5% Hydrochloric Acid, 5% Sodium Hydroxide, 5% Hydrogen Sulfide and 5% Potassium Hydroxide.

\* Requirements of ASTM C-990 Standard Specification for Joints for Concrete Pipe, Manholes, and Precast Box Sections Using Preformed Flexible Joint Sealants.

**LIMITED WARRANTY**

This information is presented in good faith, but we cannot anticipate all conditions under which this information and our products, or the products of other manufacturers in combination with our products, may be used. We accept no responsibility for results obtained by the application of this information or the safety and suitability of our products, either alone or in combination with other products. Users are advised to make their own tests to determine the safety and suitability of each such product or product combinations for their own purposes. It is the user's responsibility to satisfy himself as to the suitability and completeness of such information for this own particular use. We sell this product without warranty, and buyers and users assume all responsibility and liability for loss or damage arising from the handling and use of this product, whether used alone or in combination with other products.

# TAPECOAT® M860 PAVEMENT REPAIR COATING

## Protection for Concrete and Asphalt Surfaces



Tapecoat M860 provides quick and easy repair of cracks in concrete and asphalt surfaces. This cold-applied, self-adhering tape is effective as a temporary patching material and also offers excellent bonding for repair of the substrate prior to a complete asphalt overlay. Tapecoat M860 solves maintenance problems in paving material on city streets, highways, and parking structures. This puncture-resistant coating can also protect transducer and sensor wiring from tire damage, prevent pavement deterioration due to deformation in heavy-traffic areas, and provide quick temporary repair to paved surfaces on bridges and airport runways and tarmacs. Tapecoat M860 retains its ability to bond under pressure at temperatures as low as 0° F, making this coating ideal for temporary repairs during the cold winter months.



# Tapecoat® M860 Pavement Repair Coating

- *Excellent bond to concrete and asphalt surfaces*
- *Applies easily in long lengths or short pieces*
- *Cold-applied tape with quick release liner*
- *Impermeable to water and salt*
- *Puncture-resistant*
- *Prefabricated to provide uniform thickness*
- *Environment-friendly*

## Features/Specifications/Application

### Tapecoat® M860

*A pre-formed, cold-applied, self-adhering material that is impermeable to water and salt.*

### Composition

Tapecoat M860 is a pre-formed, cold-applied coating. The adhesive is manufactured from specially formulated elastomer and resins bonded to a woven highly puncture-resistant polymer.

### Technical Data

Color:	Black
Shelf life:	Rotate stock yearly
Low temp flex:	Excellent
Bacteria resistance:	Excellent
Thickness:	.060" Nominal
Water Vapor	
Transmission Rate,	0.01 perms(grams/sq.ft.hr./in.
Permeance:	Hg) Maximum
Tensile Strength:	50 lb.in. Minimum
Puncture Resistance:	200 lb. Minimum
(Mesh)	
Pliability-1/4" Mandrel	
180° bend -30°F:	No cracks in mesh or adhesive

### Surface Preparation

Tapecoat M860 should be applied over dry pavement that is free of dirt, debris or other foreign matter. Pavement cracks wider than 3/8" should be pre-filled with hot or cold crack material prior to applying Tapecoat M860 to assure longer protection of the crack filling material against surface wear.

### Option

If the application is taking place in extreme cold (below 32°F/0°C) a liquid primer will enhance the immediate bond. TC Omniprime is the compatible primer for use with this product.



PO Box 631, Evanston, IL 60204-0631 • 1527 Lyons St. Evanston, IL 60201-3551 USA  
800/758-6041 847/866-8500 Fax: 800/332-8273 Fax: 847/866-8596 www.tapecoat.com



# KOR-N-SEAL® I & II FLEXIBLE PIPE-TO-MANHOLE CONNECTORS

## SPECIFICATION SHEET



### KOR-N-SEAL I - WEDGE KORBAND CONNECTOR ASSEMBLY



Install Kor-N-Seal I - Wedge Korbond with Socket Wrench & Torque Limiter

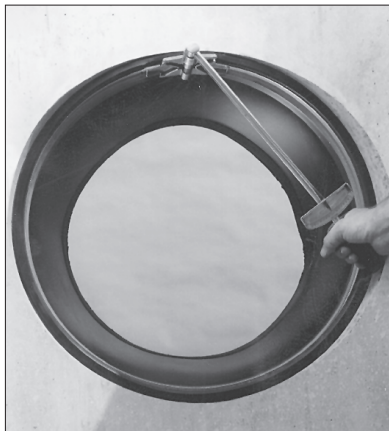

Install Kor-N-Seal II - Wedge Korbond with Standard Torque Wrench



Install Pipe Clamp(s) with T-Handle Torque Wrench





# **KOR-N-SEAL® I & II**

## *Flexible Pipe-to-Manhole Connectors*

### **SPECIFICATION SHEET**

#### **PERFORMANCE**

Test	ASTM Method	Test Requirements	Kor-N-Seal® I & II
Head Pressure	C923 - 7.1	0° - 13 psi (30 ft) for 10 min. 7° - 10 psi (23 ft) for 10 min.	+13 psi for 10 min. +10 psi for 10 min.
Deflection Test	C923 - 7.2.2	7° in any direction	Over 7° in any direction
Load Test	C923 - 7.2.3	150 lbs/in. pipe dia.	Over 150 lbs/in. pipe dia.

Performed on all standard sizes of Kor-N-Seal Connectors.

#### **RESILIENT EPDM OR POLYISOPRENE RUBBER**

**Conforms to ASTM C923**

Test	ASTM Method	Test Requirements	TEST RESULTS Kor-N-Seal® I & II
Chemical Resistance	D543, at 22°C for 48 h		
1 N Sulfuric Acid		No weight loss	No weight loss
1 N Hydrochloric Acid		No weight loss	No weight loss
Tensile Strength	D412	1200 psi	1580 psi
Elongation at Break		350% min.	500%
Hardness	D2240 (shore A durometer)	± 5 from the manufacturer's specified hardness	48 ± 5
Accelerated Oven-Aging	D573 70 ± 1°C for 7 days	Decrease of 15%, max. of original tensile strength, decrease of 20% max. of elongation	10.1% tensile decrease 14.0% elongation decrease
Compression Set	D395, method B, at 70°C for 22 h	Decrease of 25%, max. of original deflection	13% decrease
Water Absorption	D471, immerse 0.75 by 2-in. specimen in distilled water at 70°C for 48 h	Increase of 10%, max. of original by weight	.8% increase
Ozone Resistance	D1171	Rating 0	Rating 0
Low-temperature Brittle Point	D746	No fracture at -40°C	No fracture at -40°C
Tear Resistance	D624, method B	200 lbf/in.	No tear at 210 lbf/in.

#### **INTERNAL KORBAND**

**Conforms to ASTM C923, ASTM A666, and A240**

- Korband Assembly is manufactured of 300 series stainless steel.
- Toggle Expander is made of 300 series stainless steel.
- The 106/406 series Wedge Expander is made from reinforced nylon or 300 series stainless steel.
- The 206/306 series Wedge Expander is made from 300 series stainless steel.

#### **EXTERNAL PIPE CLAMP**

**Conforms to ASTM C923, ASTM A666, and A240**

External take-up clamps are manufactured of 300 series stainless steel.

**www.npc.com**

250 Elm Street • P.O. Box 301  
Milford, NH 03055, U.S.A.

Tel: 603-673-8680 • 800-626-2180 • Fax: 603-673-7271

# NPC Kor-N-Seal Pipe-to-Manhole Connector

## Technical Specification

### Scope:

This specification describes the function of the NPC Kor-N-Seal pipe-to-manhole connector, its principle of operation, and the component materials that constitute the Kor-N-Seal connector, and their physical properties.

### Product Application:

NPC Kor-N-Seal connectors are designed and manufactured to meet or exceed the requirements of ASTM C-923 "Standard Specification for Resilient Connectors Between Reinforced Concrete Manhole Structures, Pipes and Laterals". This specification requires the connector to provide a watertight seal under the following conditions:

- 10 PSI (23 feet head) of groundwater pressure
- Minimum 7 Degrees of pipe articulation in any direction
- Radial loading test of 150 pounds per inch diameter of pipe

### Principle of Operation:

The Kor-N-Seal connector creates a watertight seal between the pipe and manhole by first sealing to the inside of the cored or formed hole in the manhole and then sealing to the outside of the pipe. See illustration at right.

The seal at the inside of the manhole is created by the stainless steel Korband. The Korband is located inside of the end of the Kor-N-Seal connector that fits into the manhole. Once the Kor-N-Seal connector is located in the manhole, the diameter of the Korband is increased. This compresses the Kor-N-Seal connector against the inside wall of the hole in the manhole creating a watertight seal at the manhole.

The seal at the outside of the pipe is created by the stainless steel pipe clamp(s). The pipe clamp is located on the outside of the Kor-N-Seal connector. Once the pipe has been positioned in the connector the diameter of the pipe clamp is decreased. This compresses the Kor-N-Seal connector against the outside wall of the pipe creating a watertight seal at the pipe.

Reference the [Kor-N-Seal Recommended Installation Instructions](#) for a detailed explanation of the preparation and installation of the Kor-N-Seal connector.

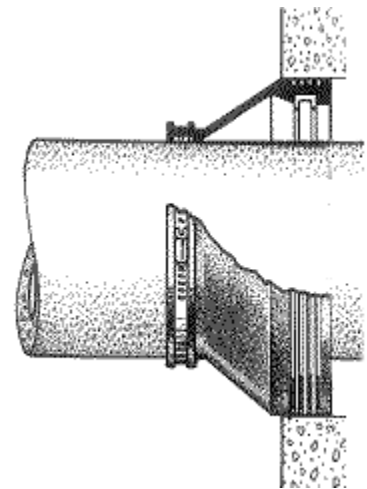



# KOR-N-SEAL – STAINLESS STEEL WEDGE

## Recommended Installation Procedure

Refer to reverse side *Kor-N-Seal I - Wedge Korband Installation Chart* for Hole Size Range, Connector Dimensions, and Suggested Pipe O.D. Range.

### CONNECTOR INSTALLATION:

1. Check to be sure Korband is properly located in Connector groove. (Fig. 1)
2. Insert Connector Assembly into hole with Wedge Expander at top of hole. (Fig. 2)
3. Position Connector so it is square to manhole both vertically and horizontally. (Fig. 3)
4. Tighten Wedge Expander using 1/2" [13 mm] socket with a preset torque limiter for each. For each size connector use torque limiter preset to proper torque. (Fig. 4) Retorquing is not required prior to shipment.

**CAUTION: DO NOT USE IMPACT WRENCH.**

### IMPORTANT

RECOMMENDED TORQUE		TORQUE LIMITER
Connector Inches [mm]	Foot Pounds [Newton Meters]	P/N
10 – 24 [254 – 610]	12 [16]	91440-12

Fig. 4

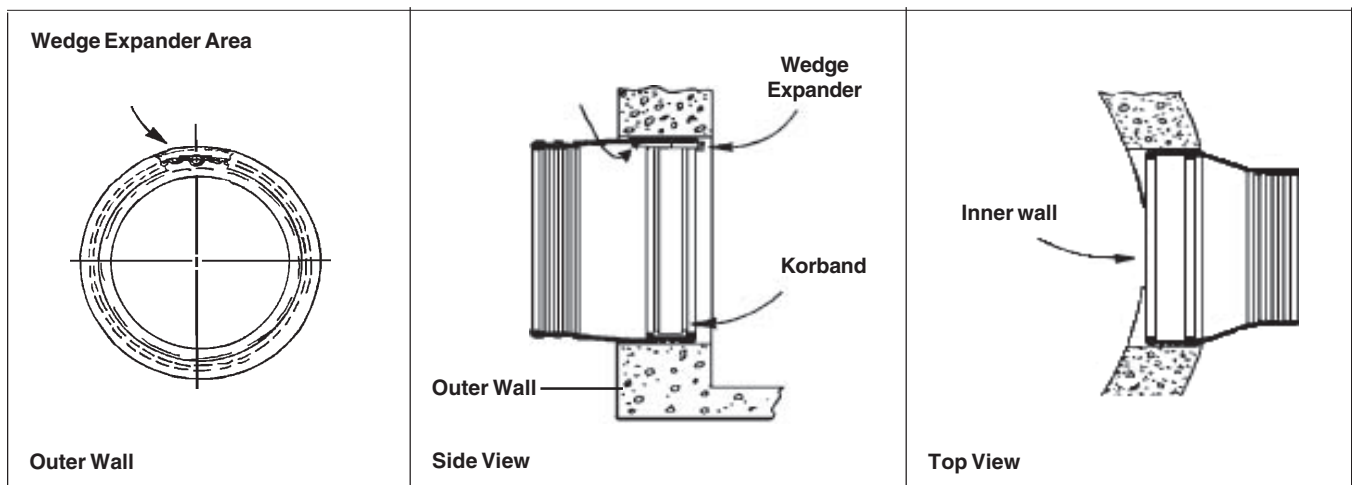

Fig. 1

Fig. 2

Fig. 3

### PIPE INSTALLATION:

1. Center pipe in Connector opening.
2. On maximum pipe O.D. installations, use a pipe lubricant on the outside barrel of the pipe and/or the inside ridges of the Connector (under the Pipe Clamp area) to allow the pipe to slide into place more easily.
3. Position the Pipe Clamp in the Connector's Pipe Clamp groove with the screw at the top.
4. Tighten the Pipe Clamp screw to 60 inch pounds [7 Newton Meters] with a T-handle Torque Wrench, P/N 80090.
5. On minimum pipe O.D. installations, lift the rubber up underneath the Pipe Clamp screw so that the Connector contacts the bottom surface of the pipe while the Pipe Clamp screw is being tightened. Application of pipe lubrication on the underside of the clamp will also help assure that an even contraction of rubber is maintained throughout the clamping area.
6. After the Pipe Clamp has been tightened down firmly, move the pipe horizontally and/or vertically to bring it to grade.

**CAUTION:** Pipe must **NOT** rest on Connector Korband.

#### CAUTION:

All capped stubs awaiting pipe installation at a later date must be restrained. Assure that a proper backfill material is used in adverse conditions. Prior to any critical usage, contact NPC Customer service at 1-800-626-2180.



[www.npc.com](http://www.npc.com)

250 Elm Street • P.O. Box 301  
Milford, NH 03055, U.S.A.

Tel: 603-673-8680 • 800-626-2180 • Fax: 603-673-7271



# KOR-N-SEAL – STAINLESS STEEL WEDGE

## Recommended Installation Procedure

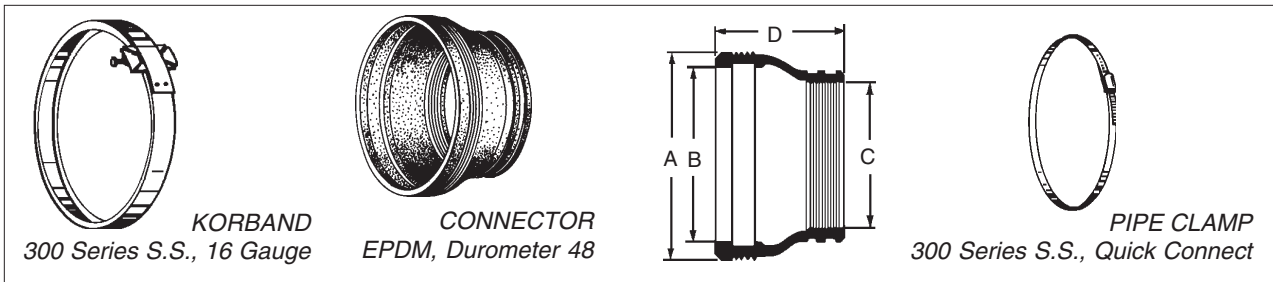

### Kor-N-Seal S106 Series

Connector P/N	Suggested Pipe O.D. Range Inches	Hole Size Range Inches	Connector Dimensions Inches			Pipe Clamp P/N
		A	B	C	D	
S106-12BWS	5.75 — 7.00	12.00 — 12.20	10.30	6.50	8	I-128
S106-12AWS	7.00 — 8.50	12.00 — 12.20	10.30	8.00	8	I-180
S106-12WS	8.25 — 9.75	12.00 — 12.20	10.30	9.25	8	I-180
S106-14AWS	9.50 — 11.25	14.00 — 14.20	12.25	10.50	8	I-190
S106-16BWS	9.50 — 11.25	15.95 — 16.15	14.30	10.50	8	I-190
S106-16AWS	11.25 — 13.00	15.95 — 16.15	14.30	12.25	8	I-218
S106-16WS	13.00 — 14.20	15.95 — 16.15	14.30	14.00	8	I-242
S106-20BWS	14.00 — 15.50	19.95 — 20.10	18.25	15.00	8	I-306
S106-20AWS	15.50 — 17.00	19.95 — 20.10	18.25	16.50	8	I-306
S106-20WS	17.00 — 18.15	19.95 — 20.10	18.25	18.00	8	I-306
S106-22WS	17.75 — 19.25	21.95 — 22.10	20.25	18.75	8	I-318
S106-24WS	19.60 — 21.10	23.95 — 24.10	22.25	20.60	8	I-348

### Kor-N-Seal S406 Series

S406-10AWS	6.00 — 6.75	10.00 — 10.20	8.30	6.50	6	I-128
S406-10WS	7.50 — 8.20	10.00 — 10.20	8.30	8.50	6	I-180
S406-10.5AWS	6.00 — 6.75	10.50 — 10.70	8.80	6.50	6	I-128
S406-10.5WS	7.50 — 8.70	10.50 — 10.70	8.80	8.50	6	I-180
S406-11BWS	6.00 — 7.00	11.00 — 11.20	9.30	6.00	6	I-128
S406-11AWS	7.50 — 9.00	11.00 — 11.20	9.30	8.00	6	I-180
S406-12CWS	6.00 — 7.00	12.00 — 12.20	10.30	6.50	6	I-128
S406-12BWS	6.25 — 7.50	12.00 — 12.20	10.30	7.00	6	I-128
S406-12AWS	7.50 — 9.00	12.00 — 12.20	10.30	8.50	6	I-180
S406-12WS	9.00 — 10.20	12.00 — 12.20	10.30	10.00	6	I-180

Suggested pipe O.D. range comes from field experience. Refer to *Recommended Pipe Installation Procedure*.



[www.npc.com](http://www.npc.com)

250 Elm Street • P.O. Box 301  
Milford, NH 03055, U.S.A.

Tel: 603-673-8680 • 800-626-2180 • Fax: 603-673-7271

08/06



# VAL-MATIC®

# SURGEBUSTER!®

Bulletin 7200

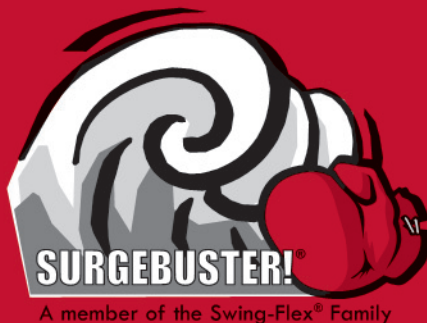

**BUILT WITH  
ADVANCED  
TECHNOLOGY  
TO WITHSTAND  
YOUR TOUGHEST  
APPLICATIONS**

*Air Release Air Valves*

*Air/Vacuum Air Valves*

*Combination Air Valves*

*Well Service Air Valves*

*Wastewater Air Valves*

*Surge-Suppression Air Valves*

*Vacuum Relief Air Valves*

*SURGEBUSTER® Check Valves*

*Tilted Disc® Check Valves*

*Swing-Flex® Check Valves*

*Dual Disc® Check Valves*

*Silent Check Valves*

*American-BFV® Butterfly Valves*

*Cam-Centric® Plug Valves*

*Sure Seal Foot Valves*

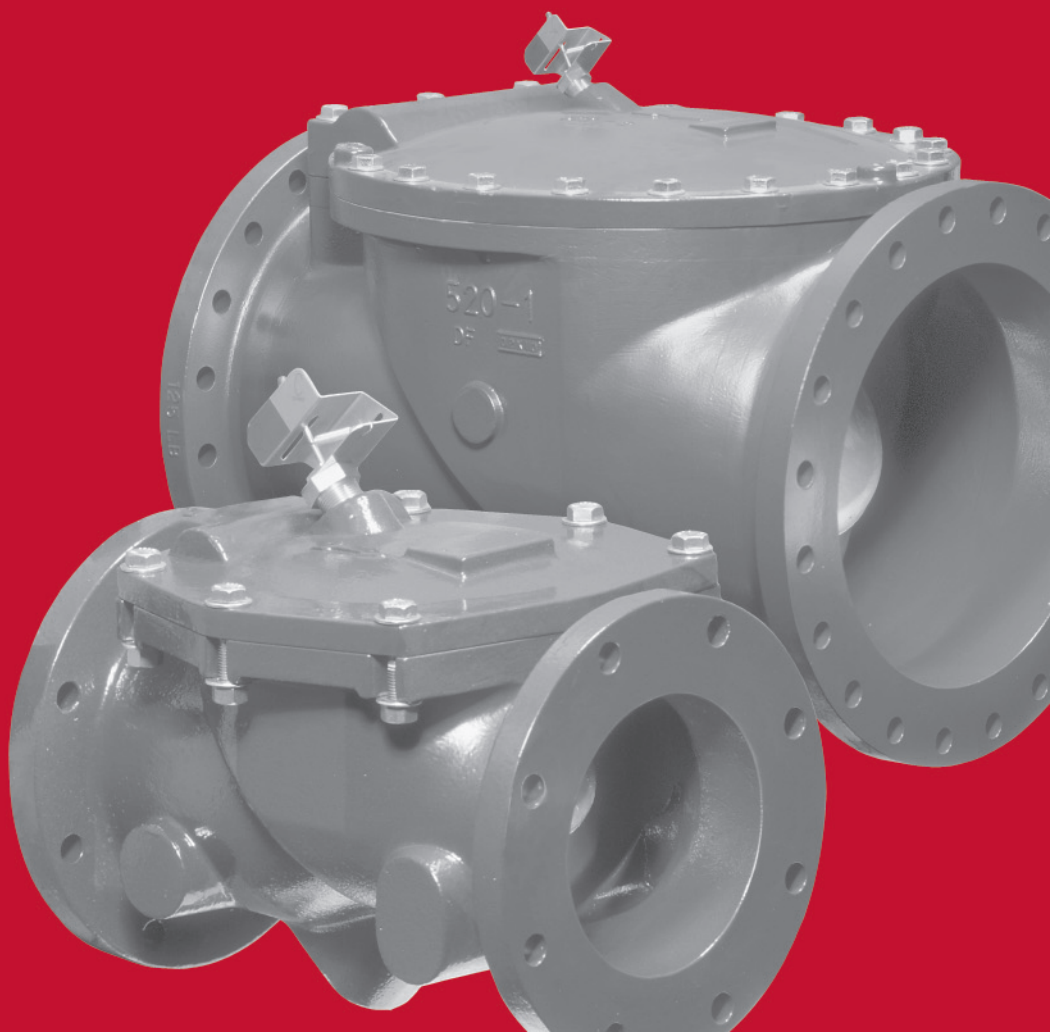

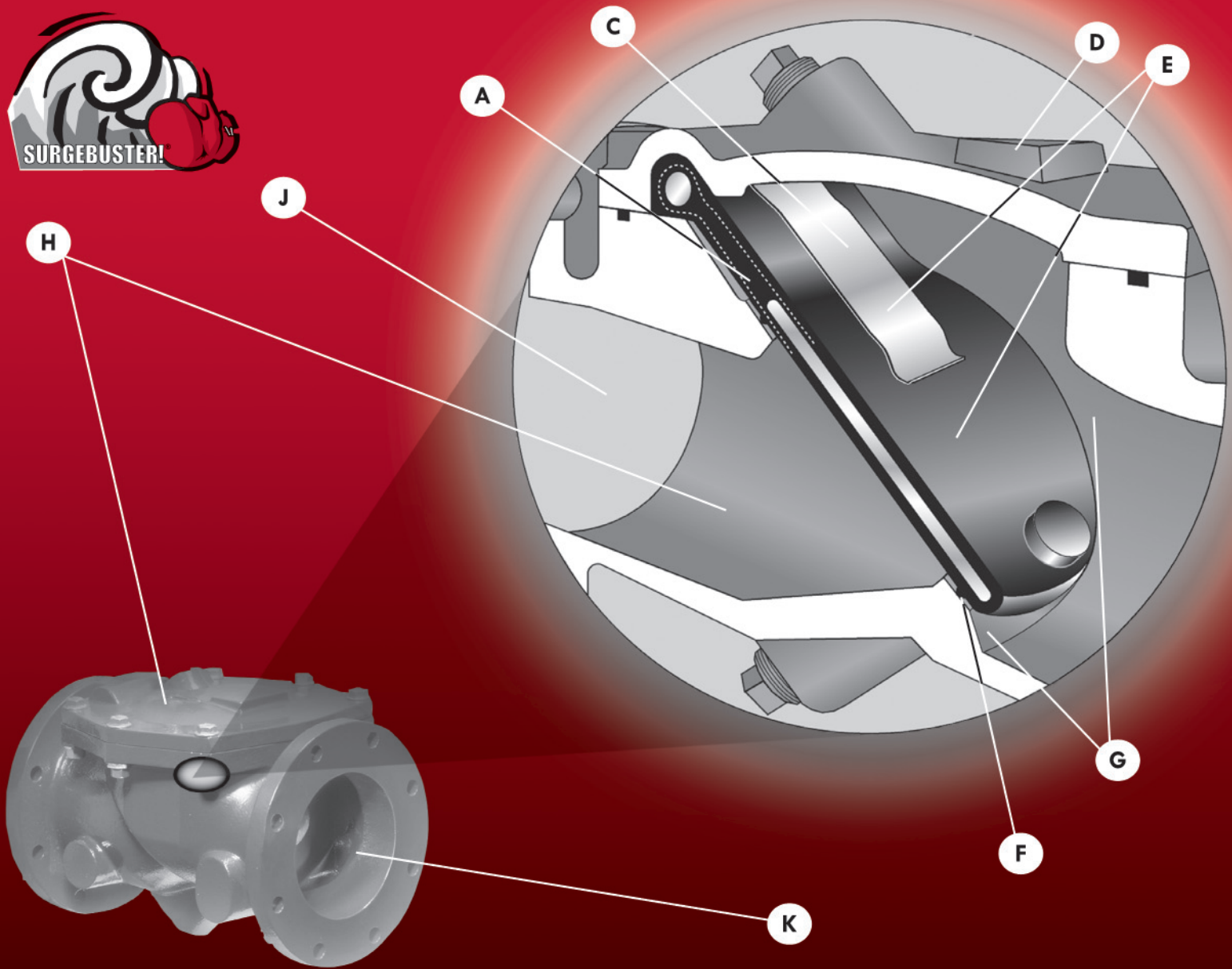

**A. REINFORCED DISC**

The one piece precision molded disc is steel and nylon reinforced to provide years of trouble free performance. It is backed by a 25 year warranty for the flex portion of the disc.

**B. MECHANICAL DISC POSITION INDICATOR\* (Optional)**

Provides clear indication of the valves disc position. Can also be provided with a SCADA compatible limit switch for off site monitoring (Not shown, see options).

**C. DISC ACCELERATOR™\*\***

The signature SURGEBUSTER® Disc Accelerator™ moves in perfect tandem with the reinforced disc to quickly and efficiently speed the closure of the disc.

**D. DOMED ACCESS PORT**

Full size top access port allows removal of disc without removing valve from line and

provides for flushing action over the valve disc for clog free performance. Access cover includes a drilled and tapped port for installation of optional Disc Position Indicator.

**E. ONLY TWO MOVING PARTS**

The Memory-Flex™ Disc and Disc Accelerator™ are the only moving parts. There are no packing or O-rings, mechanical hinges, pivot pins or bearings to wear out. Hinge portion of disc is warranted for 25 years.

**F. DROP TIGHT SEATING**

The synthetic reinforced disc, with its integral O-ring type seal design, assures positive seating at high and low pressures.

**G. NON-SLAM CLOSURE**

"Short Disc Stroke" combined with Memory-Flex™ Disc action and the Disc Accelerator™ reduce potentially destructive water hammer.

**H. FUSION BONDED EPOXY**

Fusion Bonded Epoxy (FBE) is provided standard on the interior and exterior of the valve. The FBE is ANSI/NSF 61 certified. Other coatings are available on request.

**I. BACKFLOW ACTUATOR (Optional)**

Body is drilled and tapped for installation of optional backflow actuator (Not shown, see options).

**J. NON-CLOG DESIGN**

The unrestricted full flow area combined with smooth streamlined contouring allows passage of large solids minimizing the potential for clogging.

**K. 100% FLOW AREA**

For improved flow characteristics and lower head loss, the Val-Matic SURGEBUSTER® Swing Check Valve provides 100% unrestricted flow area.

**P**umping applications with high head, surge tanks, or multiple pumps, have long proved a challenge to system operators trying to minimize line surges resulting from slamming check valves.

Only one real cause exists for slamming check valves -- reverse flow. The impact of the reverse flow is direct and proportional, the faster the reverse flow, the more violent the slam. If reverse flow through the check valve is allowed to develop, the reverse flow will slam the disc into the seat and create a loud water hammer or surge.

**Now system operators have the solution...the SURGEBUSTER®!**  
**The newest member of the Swing-Flex® family.**

The SURGEBUSTER® is a swing check valve that fully meets ANSI/AWWA C508. But here is where the similarities to traditional swing check valves end.

The SURGEBUSTER® achieves rapid closure through a short disc stroke of 35° and adjustable Disc Accelerator™. The short disc stroke is less than half the typical 80° to 90° stroke of a conventional swing check valve. It is achieved by placing the valve seat on a 45° angle while maintaining a full flow area equal to the mating pipe (Figures 1 & 2.)

The Disc Accelerator™ is a precision formed

stainless steel mechanism that closes the valve disc rapidly thus avoiding slamming by flow reversal and yet allowing the disc to be stabilized under flow conditions. The accelerator is fully enclosed within the valve and completely out of the flow path (Figures 1 & 2).

### VAL-MATIC SURGEBUSTER® VALVE

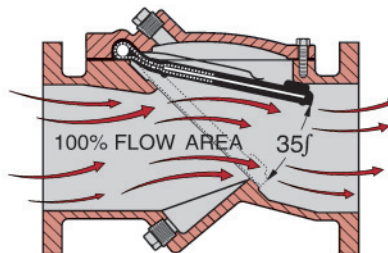

Figure 1

### CONVENTIONAL SWING CHECK VALVE

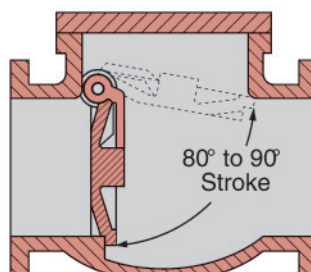

Figure 2

Traditional swing check valves use outside levers with weights or springs in an attempt to reduce slam. By doing so, they pull the disc down into the flow and reduce the length of the disc stroke so that it closes faster.

Unfortunately, while outside levers and weights help solve one problem, they create two others. Increased headloss and maintenance are inevitable with traditional swing check valves. Pulling the disc down into the flow creates a blockage in the line and causes tremendous headloss and turbulence. With the disc oscillating in the flow, the shaft, bearings, and shaft seal are all subjected to severe wear and reduced service life.

In many applications, even this approach has proven ineffective and led to the inclusion of an air cushion cylinder. The air cushion is attached to the weight or spring powered lever that is pulling the disc down. The traditional air cushion on the other hand is working in reverse by slowing the disc through its full stroke and allowing reverse flow to build. The end result, especially on fast flow reversal systems, is a slamming check valve and water hammer.

The SURGEBUSTER® with its short 35-degree stroke and Disc Accelerator™ provide fast closure thereby preventing slam and the resultant surge without obstructing flow or the need for maintenance.

Val-Matic is so confident in the SURGEBUSTER'S non-slam performance that we guarantee\* the valve will outperform any air cushion swing check valve with weight and lever.

\*Warranty details available upon request.



## Optional Accessories

**RUBBER LINING** -- Unlike conventional swing check valves, the SURGEBUSTER® Check Valve is designed to accept synthetic or natural rubber lining. Body lining coupled with synthetic *Memory-Flex*™ discs makes the SURGEBUSTER® ideally suited for systems containing abrasive or corrosive fluids.

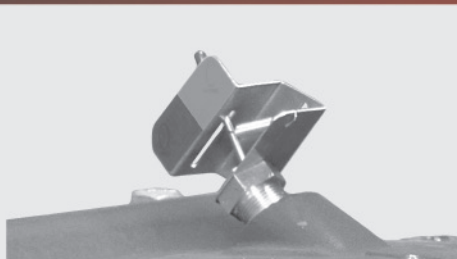
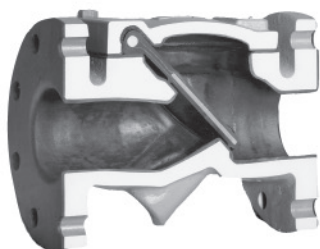

**DISC POSITION INDICATOR** -- The cover mounted disc position indicator provides clear indication of the valve's disc position. A SCADA compatible limit switch can also be provided. Both can be provided at the time of valve purchase or for field installation at a later date.

**BACKFLOW ACTUATOR** -- Available for use when manual backflow operation is required. Most commonly used for priming pumps, back flushing, draining lines, and system testing. The Val-Matic Backflow Actuator can be provided at the time of valve purchase or for field installation at a later date.

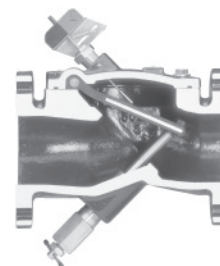



# Head Loss Chart

HEAD LOSS IN FEET OF WATER

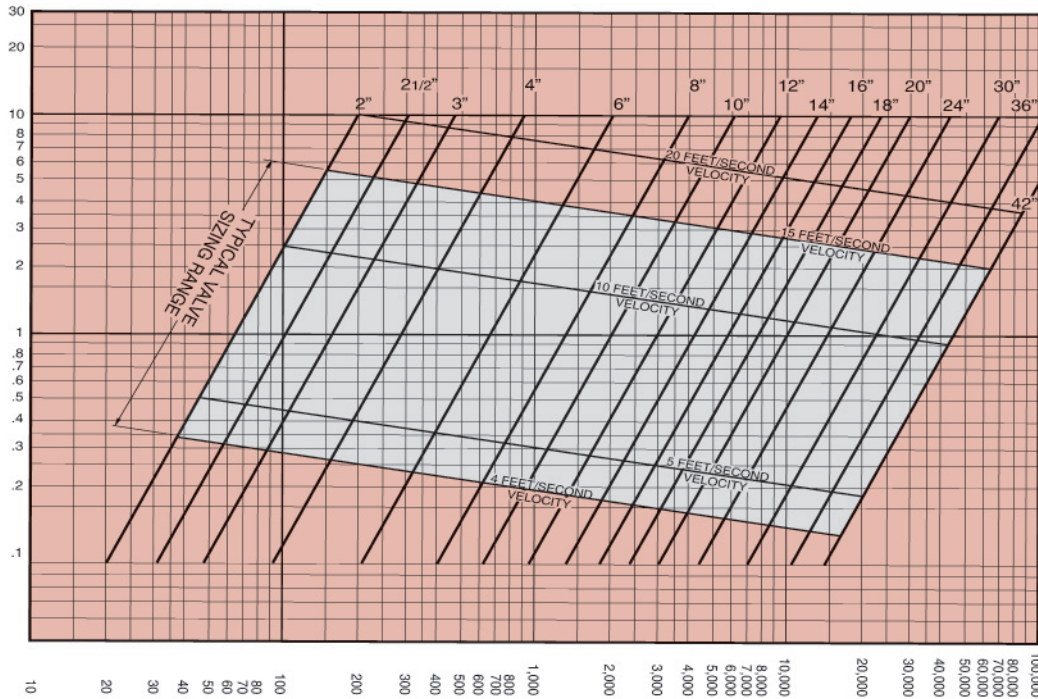

FLOW OF WATER IN GALLONS PER MINUTE

Consult factory for Digester Gas Service

Flow Tests performed by the Utah Water Research Laboratory of Utah State University.



## Installation Dimensions and Construction

VALVE SIZE	MODEL NO.	A	E	F1	F2	H	J	K	L
2	7202	8.00	2.00	N/A	3.38	-0.50	6.75	1.50	1.50
2 1/2	7225	8.50	2.50	N/A	3.38	-0.50	7.00	1.50	1.50
3	7203	9.50	3.00	7.63	5.12	-0.38	7.50	1.50	1.50
4	7204	11.50	4.00	8.25	5.75	4.13	11.63	2.25	2.25
6	7206	15.00	6.00	9.38	6.88	2.00	12.00	2.25	2.25
8	7208	19.50	8.00	11.00	8.38	2.00	15.75	5.75	5.75
10	7210	24.50	10.00	13.38	10.75	0.50	17.00	5.75	5.75
12	7212	27.50	12.00	15.00	12.50	3.50	22.50	6.50	6.50
14	7214	31.00	14.00	17.63	13.00	4.00	26.25	6.50	6.50
16	7216	32.00	16.00	18.88	14.25	4.63	30.00	6.50	6.50
18	7218	36.00	18.00	20.00	15.25	5.25	33.75	6.50	6.50
20	7220	40.00	20.00	21.38	16.88	5.88	37.50	8.00	8.00
24	7224	48.00	24.00	23.88	19.25	7.00	45.00	8.00	8.00
30	7230	56.00	30.00	27.63	23.00	-0.63	41.25	8.00	8.00
36	7236	63.00	36.00	31.00	27.38	-6.12	43.50	8.00	8.00
42	7242	70.00	42.00	39.12	36.88	-11.00	48.12	8.00	8.00

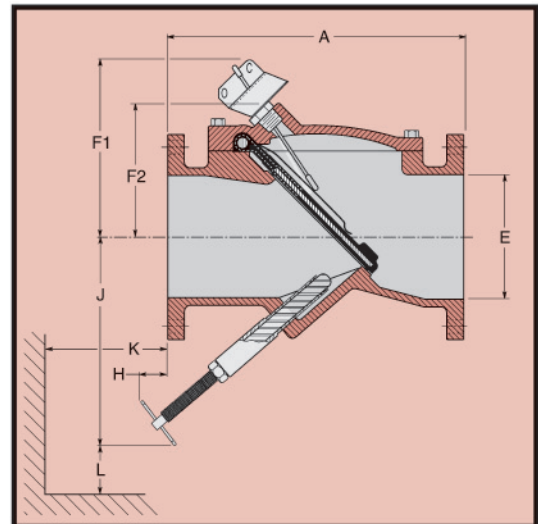

\*Dimension "E" represents nominal valve size.  
Note: Flanged ends conform to ANSI B16.1 Class 125.

Dimensions "L" and "K" represent the clearance required to remove backflow actuator.

MATERIALS OF CONSTRUCTION			
Component	Standard	Optional	
Body and Cover	Ductile Iron ASTM A536 Grade 65-45-12	Stainless Steel, Bronze	
Disc	Buna-N (NBR), ASTM D2000-BG	Viton (FKM), ASTM D2000-HK	
Disc Accelerator	TYPE 302 Stainless Steel	N/A	
Coatings	Interior	Fusion Bonded Epoxy*	Rubber Lining
	Exterior	Fusion Bonded Epoxy*	Consult Factory

Consult factory for additional material and coating options.  
\*ANSI/NSF 61 Certifications

ANSI MAXIMUM PRESSURE-TEMPERATURE RATING		
Maximum Non-Shock Working Pressure (P.S.I.) ANSI Class 125		
Temperature °F	2" - 24"	30" - 36"
100°	250	150
150°		
200°	235	135
Hydrostatic Test Pressures	375	230

For higher temperatures consult factory.



# **SURGEBUSTER® Swing Check Valve Specification**

**1.1** This specification is intended to cover the design, manufacture, and testing of 2 in. (50 mm) through 42 in. (1000 mm) Surgebuster® Swing Check Valves suitable for cold working pressures of 250 psig, 150 psig for 30 in. (800mm) and larger in water, wastewater, abrasive, and slurry service.

**1.2** The check valve shall be of the full body type, with a domed access cover and only two moving parts, the flexible disc and the disc accelerator.

## **Standards and Approvals**

**2.1** The valves shall be designed, manufactured and tested in accordance with American Water Works Association Standards ANSI/AWWA C508.

**2.2** Manufacturer shall have a quality management system that is certified to ISO 9001 by an accredited, certifying body.

## **Connections**

**3.1** Valves shall be provided with flanges in accordance with ANSI B16.1, Class 125.

## **Design**

**4.1** The valve body shall be full flow equal to nominal pipe diameter at all points through the valve. The 4 in. (350mm) valve shall be capable of passing a 3 in. (75mm) sphere. The seating surface shall be on a 45 degree angle to minimizedisc travel. A threaded port with pipe plug shall be provided on the bottom of the valve to allow for field installation of a backflow actuator, air cushion or hydraulic cushion without special tools or removing the valve from the line.

**4.2** The top access port shall be full size, allowing removal of the disc without removing the valve from the line. The access cover shall be domed in shape to provide flushing action over the disc for operating in lines containing high solids content. A threaded port with pipe plug shall be provided in the access cover to allow for field installation of a mechanical, disc position indicator.

**4.3** The disc shall be of one-piece construction, precision molded with an integral o-ring type sealing surface, and contain alloy steel and nylon reinforcement in the flexible hinge area. The flex portion of the disc

shall be warranted for twenty-five years. Non-Slam closing characteristics shall be provided through a short 35 degree disc stroke and a disc accelerator to provide a cracking pressure of 0.3 psig.

**4.4** The disc accelerator shall be of one piece construction and provide rapid closure of the valve in high head applications. The disc accelerator shall be enclosed within the valve and shall be field adjustable and replaceable without removal of the valve from the line. The disc accelerator shall be securely held in place by being captured between the cover and disc. It shall be formed with a large radius to allow smooth movement over the disc surface.

**4.5** The valve disc shall be cycle tested 1,000,000 times in accordance with ANSI/AWWA C508 and show no signs of wear, cracking, or distortion to the valve disc or seat and shall remain drop tight at both high and low pressures. The test results shall be independently certified.

## **Materials**

**5.1** The valve body and cover shall be constructed of ASTM A536 Grade 65-45-12 ductile iron or ASTM A126 Class B for 30 in. and larger. Optional body materials include ASTM A-351 Grade CF8M, stainless steel (sizes 3" through 8").

**5.2** The disc shall be precision molded Buna-N (NBR), ASTM D2000-BG. Optional disc material includes Viton.

**5.3** The disc accelerator shall be type 302 stainless steel.

## **Options**

**6.1** A screw-type backflow actuator shall be provided (when specified) to allow opening of the valve during no-flow conditions. Buna-N seals shall be used to seal the stainless steel stem in a bronze bushing. The backflow device shall be of the rising-stem type to indicate position. A stainless steel T-handle shall be provided for ease of operation.

**6.2** A mechanical indicator shall be provided (when specified) to provide disc position indication on valves 4" and larger. The indicator shall have continuous contact with the disc under all operating conditions to

assure accurate disc position indication.

**6.3** A pre-wired limit switch will be provided (when specified) to indicate open/closed position to a remote location. The mechanical type limit switch shall be activated by the external position indicator. The switch shall be rated for NEMA 4, 6, or 6P and shall have U.L. rated 5 amp, 12 or 250 VAC contacts.

**6.4** A bottom mounted oil dashpot (oil cushion) shall be provided when specified to provide hydraulic control of the final 10% of valve closure and reduce valve slam and water hammer normally associated with rapid flow reversal conditions on pump shut down. The dashpot shall consist of a high pressure hydraulic cylinder, adjustable external flow control valve, oil reservoir, pressure gauge, stainless steel air inlet valve, and piping designed to control the closing speed of the last 10% of travel in 1-5 seconds. A threaded brass dashpot bushing unit with a grease fitting for lubrication shall connect the cylinder to the valve and shall have an air gap to prevent hydraulic fluid from entering the valve and contaminating the water system. A snubber rod fitted with O-ring seals and rod wiper scrapers shall make contact with the lower portion of the disc's stainless steel strike plate.

## **Manufacture**

**7.1** The manufacturer shall demonstrate a minimum of five (5) years experience in the manufacture of resilient, flexible disc check valves with air and hydraulic cushions.

**7.2** All valves shall be hydrostatically tested and seat tested to demonstrate zero leakage. When requested the manufacturer shall provide test certificates, dimensional drawings, parts list drawings, and operation and maintenance manuals.

**7.3** The exterior and interior of the valve shall be coated with an ANSI/NSF 61 approved fusion bonded epoxy coating.

**7.4** Surgebuster® Swing Check Valves shall be Series #7200 as manufactured by Val-Matic® Valve & Manufacturing Corporation, Elmhurst, IL, USA or approved equal.



# Dynamic Testing of Check Valves

## DYNAMIC TESTING OF CHECK VALVES

SURGEBUSTER® and Air Cushioned Swing Check Valves were flow tested under identical dynamic conditions and the downstream pressure plotted as shown in Figures 1 and 2. The valves were installed on the discharge of a four-inch 20 HP water pump and connected to a hydro-pneumatic tank charged to 30 psig. After pump shutdown, the water flow would rapidly reverse in about 1/2 second and cause rapid valve closure.

The Air Cushioned Swing Check Valve was equipped with a lever, weight, and air cushion with flow control valve. Despite an operating velocity over 8 feet per second, the Cushioned Swing Check Valve traveled only 15 degrees or about 25%

open. Partially open check valves are common and can cause excessive headloss and energy consumption. Adjustments to the air cushion revealed that any control setting of the cushion, slowed down the valve closure, and magnified the valve slam. In Figure 1, the valve closed with a loud slam and produced an upsurge in the downstream piping of 150 psi over the static pressure.

The SURGEBUSTER® was operated under the same flow conditions and was found to open 35 degrees or 100% open. In Figure 2, after pump shutdown the SURGEBUSTER® closed with a negligible slam and produced an upsurge in the downstream piping of only 25 psi over the static pressure.

The dynamic tests demonstrate that the SURGEBUSTER® can reduce check valve slam up to 80% when compared to conventional swing check valves. Numerous field installations with vertical lines, multiple pumps, and high pump discharge head all demonstrated the same result. The SURGEBUSTER® provides non-slam operation with reduced headloss and maintenance.

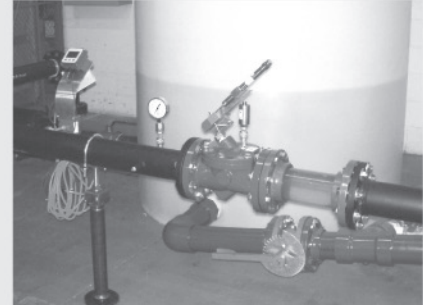

**Figure 1**

**The air cushioned swing check valve closed with a loud slam producing a 150 psi surge with optimum cushion adjustment.**

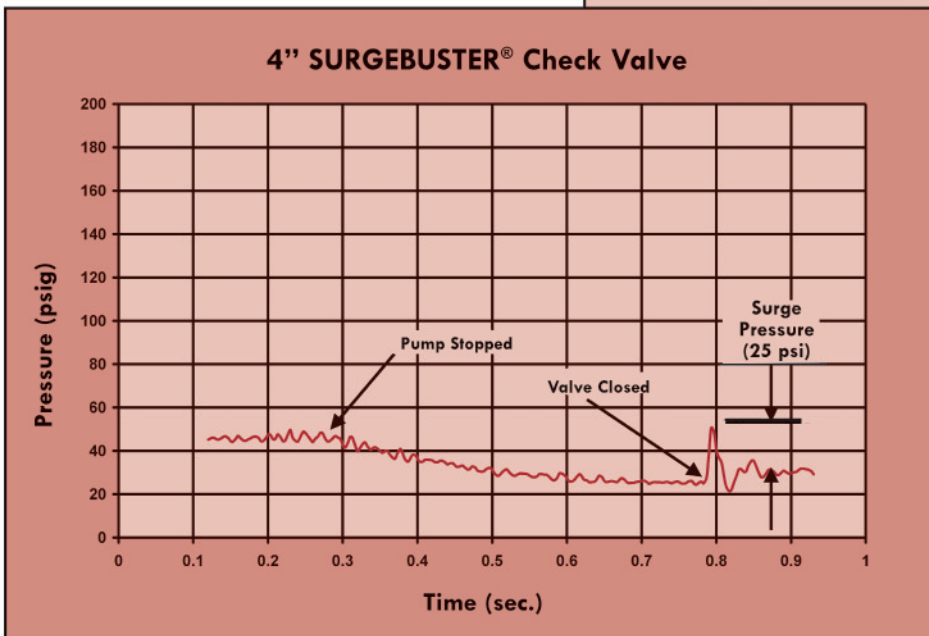
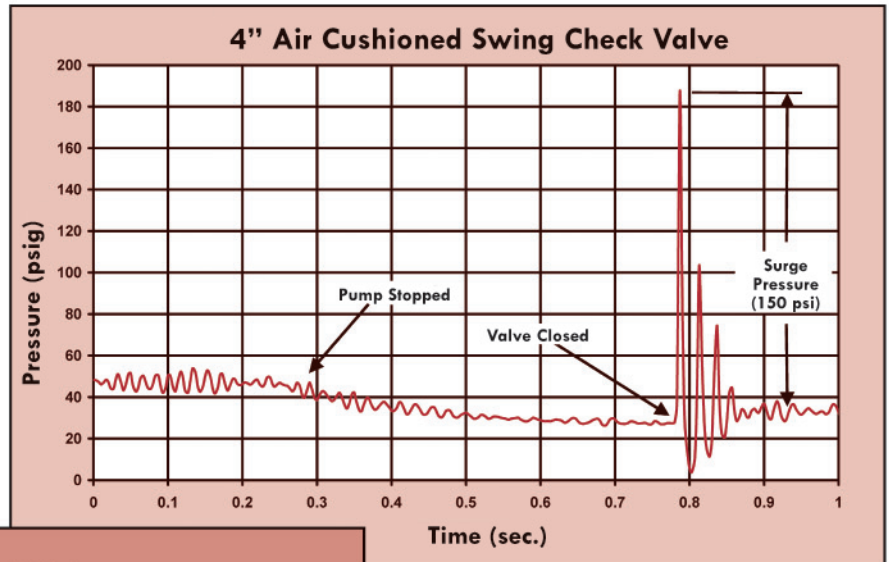

**Figure 2**

**The SURGEBUSTER® closed quietly producing only a 25 psi surge pressure, 80% less than the conventional air cushioned swing check valve.**

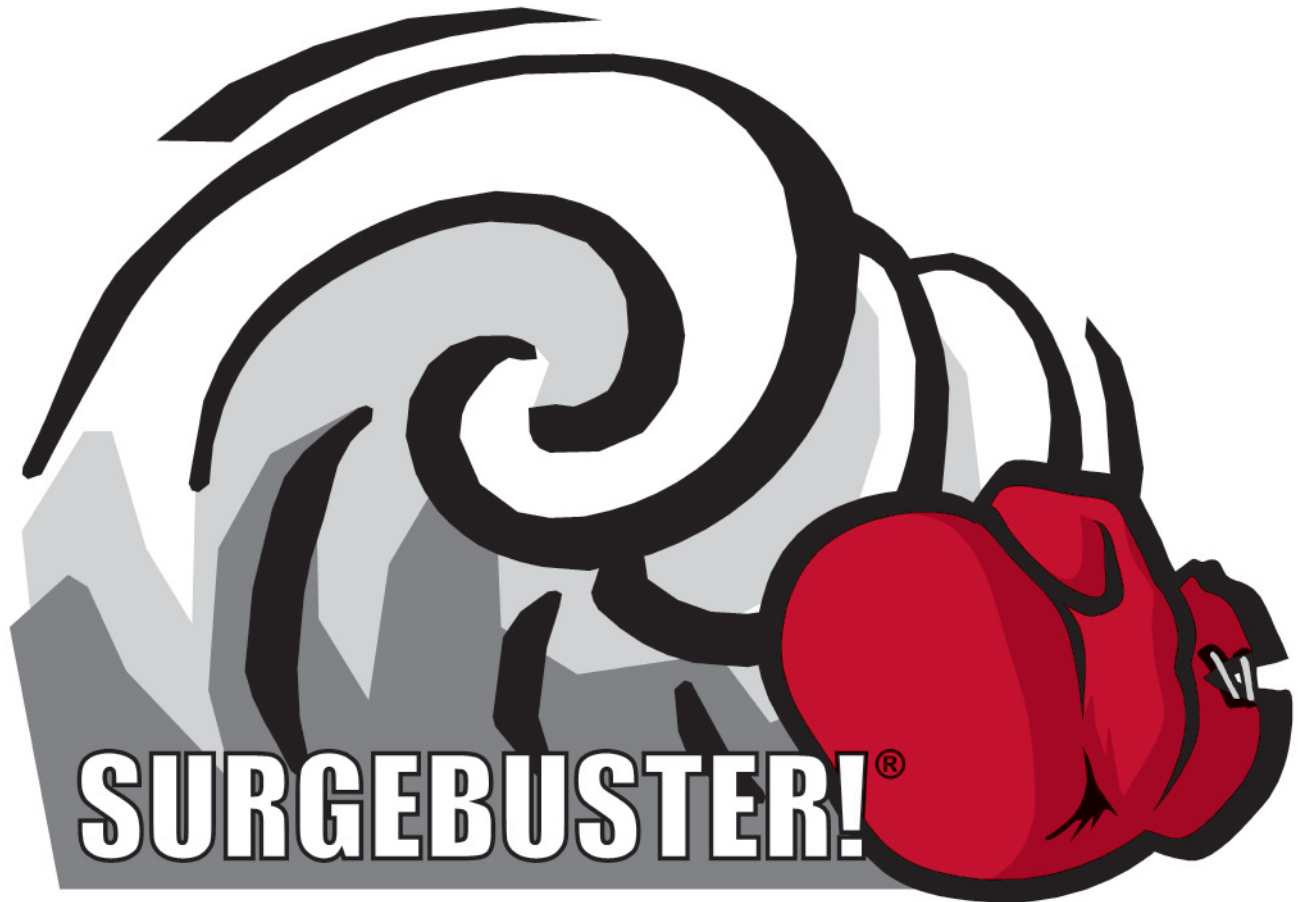

A member of the Swing-Flex® Family

**Val-Matic is so confident in the SURGEBUSTER'S non-slam performance that we guarantee\* the valve will outperform any air cushion swing check valve with weight and lever.**

**\*Warranty details available upon request.**

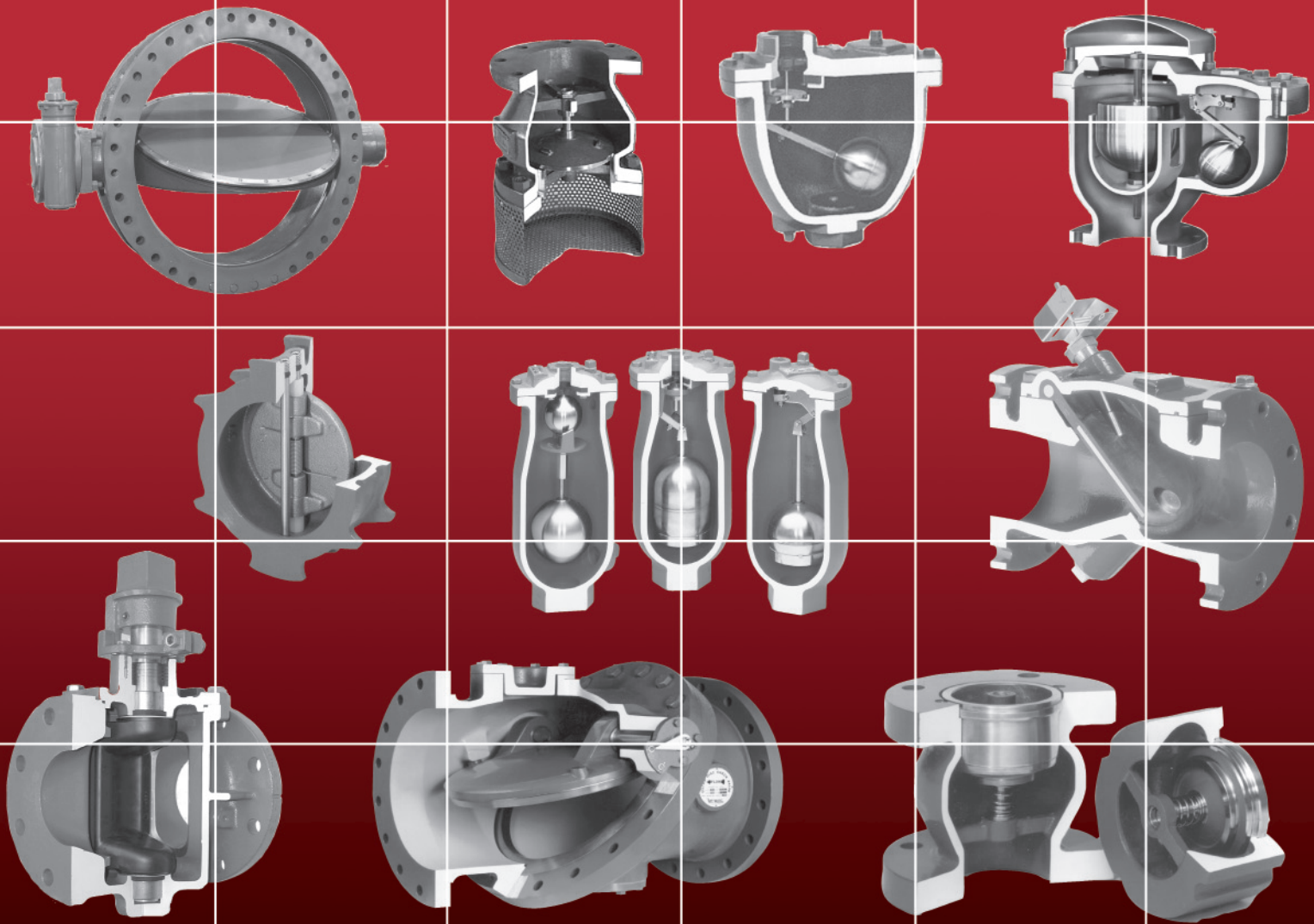

# Make the change to **QUALITY!** Specify **VAL-MATIC®**

Val-Matic's quality of design and meticulous workmanship has set the standards by which all others are measured. Quality design features such as Type 316 stainless steel trim as standard on Air Release, Air/Vacuum and Combination Air Valves...combined resilient/metal to metal seating for Silent Check® Valves...stabilized components that provide extended life of the Dual Disc® Check Valves...high strength and wear resistant aluminum bronze trim as standard for Tilted Disc® Check valves...unrestricted full flow area through Swing-Flex® Check Valves...heavy duty stainless steel screened inlet on Sure Seal® Foot Valves...a Cam-Centric®

Plug Valve with more requested features than any other eccentric plug valve, and the American-BFV® Butterfly Valve that provides a field replaceable seat without the need for special tools. These features coupled with our attention to detail put Val-Matic valves in a class by themselves.

Val-Matic is totally committed to providing the highest quality valves and outstanding service to our customers. Complete customer satisfaction is our goal.

**VAL-MATIC®**

**VAL-MATIC VALVE AND MANUFACTURING CORP.**

ISO 9001:2008 certified company

905 RIVERSIDE DRIVE • ELMHURST, IL 60126  
630/941-7600 • FAX: 630/941-8042  
www.valmatic.com      valves@valmatic.com



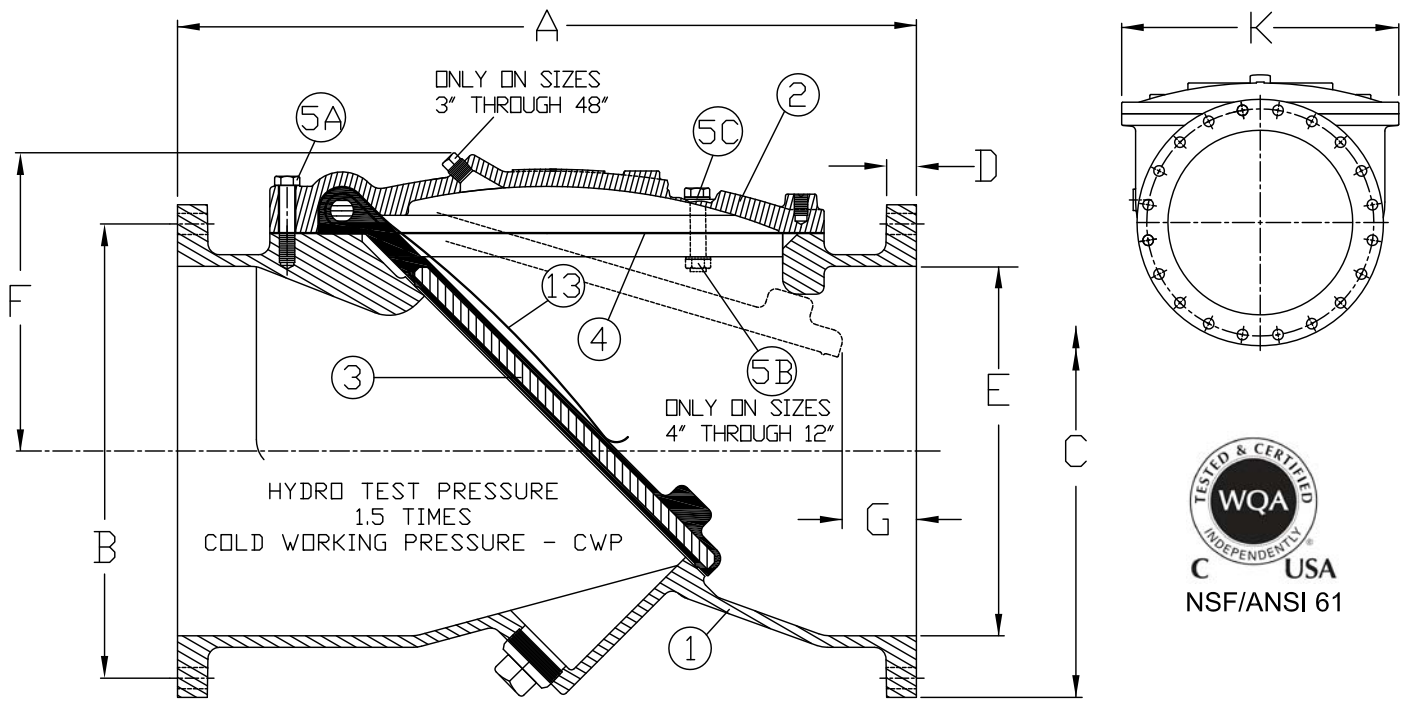

SEE DRAWING NO. VM-7202-M FOR STANDARD MATERIALS OF CONSTRUCTION.

DRAWING DEPICTS 24" SIZE TO SCALE.

ANSI CLASS 125

VALVE SIZE	MODEL NO.	CWP (PSI)	A	B	C	D	E	F	G	K	BOLT SIZE	NO. OF BOLTS
2	7202	250	8.00	4.75	6.00	0.63	2.00	3.38	1.63	5.18	5/8	4
2 1/2	7225	250	8.50	5.50	7.00	0.68	2.50	3.38	1.63	5.18	5/8	4
3	7203	250	9.50	6.00	7.50	0.75	3.00	5.12	1.63	7.50	5/8	4
4	7204	250	11.50	7.50	9.00	0.75	4.00	5.75	2.12	8.25	5/8	8
6	7206	250	15.00	9.50	11.00	0.75	6.00	6.88	2.12	11.12	3/4	8
8	7208	250	19.50	11.75	13.50	0.88	8.00	8.38	2.88	16.00	3/4	8
10	7210	250	24.50	14.25	16.00	1.18	10.00	10.75	3.12	21.00	7/8	12
12	7212	250	27.50	17.00	19.00	1.25	12.00	12.50	3.43	24.00	7/8	12
14	7214	250	31.00	18.75	21.00	1.38	14.00	13.00	3.63	23.25	1	12
16	7216	250	32.00	21.25	23.50	1.43	16.00	14.25	3.25	25.25	1	16
18	7218	250	36.00	22.75	25.00	1.56	18.00	15.25	3.12	28.25	1 1/8	16
20	7220	250	40.00	25.00	27.50	1.68	20.00	16.88	3.50	30.63	1 1/8	20
24	7224	250	48.00	29.50	32.00	1.88	24.00	19.25	5.00	36.00	1 1/4	20
30	7230	150	56.00	36.00	38.75	2.12	30.00	23.00	5.75	45.88	1 1/4	28
30	7230A	250	56.00	36.00	38.75	2.12	30.00	23.00	5.75	45.88	1 1/4	28
36	7236	150	63.00	42.75	46.00	2.38	36.00	27.38	3.88	55.00	1 1/2	32
36	7236A	250	63.00	42.75	46.00	2.38	36.00	27.38	3.88	55.00	1 1/2	32
42	7242	150	70.00	49.50	53.00	2.63	42.00	36.88	0.12	60.18	1 1/2	36
42	7242A	250	70.00	49.50	53.00	2.63	42.00	36.88	0.12	60.18	1 1/2	36
48	7248	150	76.00	56.00	59.50	2.75	48.00	40.66	0.12	68.00	1 1/2	44
48	7248A	250	76.00	56.00	59.50	2.75	48.00	40.66	0.12	68.00	1 1/2	44

Revised 3-31-11

**SURGEBUSTER CHECK VALVE**

DATE **10-17-08**

DRWG. NO.

**VMC-7202**



VALVE AND MANUFACTURING CORP.



# RFCA (Restrained Flanged Coupling Adapter)

**Material Specifications**

**Flange Body:** Ductile (nodular) iron, meeting or exceeding ASTM A 536, Grade 65-45-12. Flange meets the dimensional requirements of ANSI Class 125 and 150 bolt circles.

**Gaskets:** Compounded for water and sewer service in accordance with ASTM D 2000 (Sizes 3 - 12" have flange O-Ring gasket). Other compounds available for petroleum, chemical, or high temperature service.

**Gland:** Romac RomaGrip™. See page 7-6.

**Restraining Bolts:** 7/8 –9 roll thread, Ductile (nodular) iron, meeting or exceeding ASTM A 536.

**Restraining Lugs:** Ductile (nodular) iron, meeting or exceeding ASTM A 536. Heat treated using a proprietary process.

**Lug Locators:** Polyurethane, a thermal plastic.

**T-bolts and Nuts:** High strength low alloy steel T-head bolt. National coarse rolled thread and heavy hex nut. Steel meets AWWA C111 composition specifications. Stainless steel bolts and nuts available on request.

**Coatings:** Shop coat applied to cast parts for corrosion protection in transit. **Fusion bonded epoxy** available on request.

**Use:** Ductile Iron Pipe 3 - 24", cast iron pipe 3" - 24" (same OD's as ductile iron) and IPS size STD steel pipe 3 - 12".

**To Order:** Specify catalog number. **Example:** For a 12" RFCA Order: **RFCA - 13.20**

**NOTE:** 3" - 12" special Romac gasket works on both steel and D.I. ODs.



**Not for use on PVC, HDPE pipe or plain-end mechanical joint fittings. For applications on PVC, please contact your Romac representative.**

NOM. PIPE SIZE	GASKET RANGE	LENGTH	GLAND BOLTS QTY: SIZE	CATALOG NUMBER	LIST PRICE				WEIGHT (lbs.)
					Shopcoat w/Std. B&N	Shopcoat w/304 SS B&N	Fusion Epoxy w/Std. B&N	Fusion Epoxy w/304SS B&N	
3"	3.50-3.96	8.00"	4: 5/8" x 3"	RFCA - 3.96	\$145.45	\$157.56	\$165.10	\$177.20	21
4"	4.50-4.80	9.00"	4: 3/4" x 3 1/2"	RFCA - 4.80	183.32	209.43	207.88	233.99	29
6"	6.63-6.90	9.25"	6: 3/4" x 4"	RFCA - 6.90	233.85	273.01	267.10	306.26	40
8"	8.63-9.05	9.25"	6: 3/4" x 4"	RFCA - 9.05	315.59	354.75	355.82	394.98	53
10"	10.75-11.10	10.25"	8: 3/4" x 4"	RFCA - 11.10	581.96	634.17	669.69	721.91	83
12"	12.75-13.20	10.25"	8: 3/4" x 4"	RFCA - 13.20	632.13	684.34	739.86	792.07	110
14"	15.30	11.70"	10: 3/4" x 4 1/2"	RFCA - 15.30	882.79	947.37	1,020.54	1,085.12	170
16"	17.40	11.70"	12: 3/4" x 4 1/2"	RFCA - 17.40	1,225.93	1,302.91	1,410.23	1,487.21	200
18"	19.50	11.80"	12: 3/4" x 4 1/2"	RFCA - 19.50	1,346.63	1,423.60	1,546.13	1,623.10	217
20"	21.60	11.80"	14: 3/4" x 4 1/2"	RFCA - 21.60	1,521.19	1,611.94	1,772.94	1,863.69	256
24"	25.80	12.00"	16: 3/4" x 5"	RFCA - 25.80	1,845.38	1,959.61	2,130.38	2,244.61	305



*Some initial axial movement may occur in lug style restraints as the lugs seat. Movement is directly related to the size of the piping system and the system pressure. In general terms movement of approximately 0.25" can be expected in restraints under 16". For larger sizes, movement of approximately 0.4" may be seen. If this is critical to your application please contact Romac Engineering for additional information.*

# INSTALLATION INSTRUCTIONS

Read installation instructions first before installing. Check parts to ensure that no damage has occurred during transit and that no parts are missing. Also check the diameter of the pipe and the size marked on the coupling to ensure you have the proper size.



## RFCA Restrained Flange Coupling Adapter

NOT FOR USE ON PVC PIPE OR PLAIN END MECHANICAL JOINT FITTINGS

**NOTE:** Not for use on polyethylene pipe, plain end mechanical joint fittings or PVC pipe.

The "Stab-Fit" installation technique may also be employed on 3"-10" sizes.

**Step 1** • Check the RFCA parts to insure that no damage has occurred during transit and that no parts are missing.

**Step 2** • Clean pipe end for a distance of 2" greater than length of the RFCA.

**Step 3** • Place RomaGrip gland on pipe end.

**Step 4** • Lubricate the gasket and pipe surface with soapy water or other suitable gasket lubricant.

**Step 5** • Place gasket over pipe with beveled edge toward the flange adapter.

**Step 6** • Slide the RFCA on to the pipe. Position the pipe and flanged coupling against the mating flange, inserting flange gasket (14" and larger) between the flange faces. Assemble the flange joint using flange bolts.

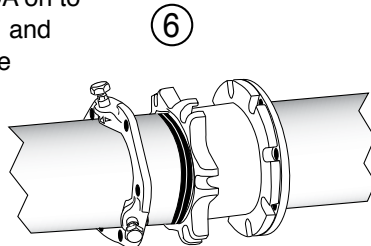

**Step 7** • The pipe should be centered such that the space between the OD of the pipe and the ID of the RFCA is even all around the pipe. Slide the RFCA gasket into position with the beveled edge engaging the beveled end of the RFCA body.

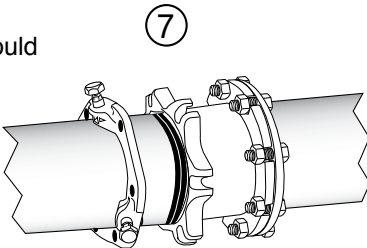

**Step 8** • Slide the RomaGrip into position against the gasket, and insert T-bolts.

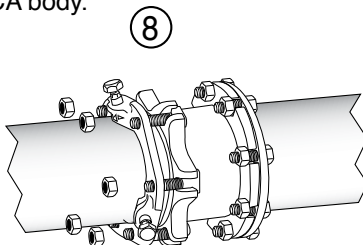

**Step 9** • Tighten T-bolts evenly, alternating to diametrically opposite position at approximately 20 ft-lbs increments to the recommended torque for your size RFCA.

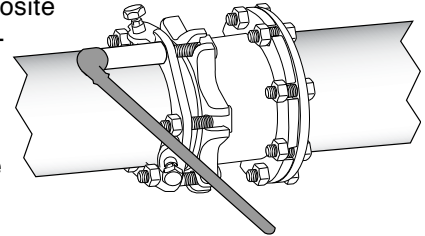

**Recommended Torque:**

- 3" RomaGrip - 45-65 ft-lbs.
- 4 - 24" RomaGrip - 75 - 90 ft-lbs.

**Note:**

90 ft-lbs. torque = 12" wrench w/90 lbs. force

For best results, wait 10 minutes and retighten bolts to proper torque.

**Step 10** • Hand tighten the restrainer bolts until the restraining pads touch the surface of the pipe. The bolts should be tightened in a uniform criss-cross pattern, until the heads break off above the notch.

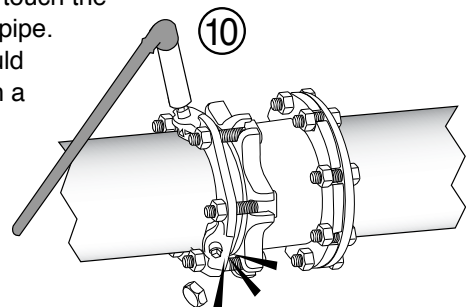

**NOTE:** Do not turn a bolt more than one turn before alternating to the next bolt.

**Step 11** • Pressure test for leaks before backfilling.



# INSTALLATION INSTRUCTIONS

## RFCA Restrained Flange Coupling Adapter

NOT FOR USE ON PVC PIPE OR PLAIN END MECHANICAL JOINT FITTINGS

### PRECAUTIONS

1. Check flange to make sure the bolt holes match the RFCA.
2. Make sure a flange gasket is used between the mating flanges on sizes 14" and larger.
3. Check diameter of pipe to make sure you are using the correct size RFCA; also check gasket to make sure it is the size you think it is.
4. Be sure to clean pipe of as much dirt and corrosion as possible in the area that the gasket will seal.
5. Lubricate both the gasket and the pipe end with soapy water or approved pipe lubricant per ANSI/AWWA C111/A21.11.
6. Make sure no foreign materials lodge between gasket and pipe.
7. Avoid loose fitting wrenches, or wrenches too short to achieve proper torque.
8. Keep threads free of foreign material to allow proper tightening.
9. Take extra care to follow proper bolt tightening procedures and torque recommendations. Bolts are often not tightened enough when a torque wrench is not used.
10. Be sure that the gland is centered around the pipe.
11. Pressure test for leaks before backfilling.
12. Backfill and compact carefully around pipe and fittings.
13. Some initial axial movement may occur in lug style restraints as the lugs seat. Movement is directly related to the size of the piping system and the system pressure. In general terms movement of approximately 0.25" can be expected in restraints under 16". For larger sizes, movement of approximately 0.4" may be seen. If this is critical to your application please contact Romac Engineering for additional information.

### COMMON INSTALLATION PROBLEMS

1. Flange gasket not installed on sizes 14" and larger.
2. T-Bolts are not tightened to the proper torque.
3. Rocks or debris between pipe and gasket.
4. Dirt or debris between pipe and restraining pad.
5. Dirt on threads of bolts or nuts.
6. Restraining bolt heads not snapped off.
7. Not enough pipe inserted into bell.
8. Using the RFCA on IPS size steel pipe with wall thickness thinner than schedule 40 steel pipe. (3-12 inch sizes)

### IF RFCA MUST BE REMOVED

1. Make sure pipe is not pressurized. Removing the restrainer could cause the pipe joint to separate.
2. To remove the RFCA, use a  $\frac{5}{8}$ " hex wrench or socket.
3. To reassemble, follow installation procedures. Tighten the restraining bolts using a  $\frac{5}{8}$ " hex wrench to 75-ft-lbs minimum.

**ROMAC INDUSTRIES, INC.**  
**ROMAGRIP**  
**MECHANICAL JOINT RESTRAINING GLAND**  
**3 THROUGH 12 INCH**  
**SUBMITTAL INFORMATION**

**USE** The Romac RomaGrip restraining gland is used for the restraint of mechanical joint ductile iron pipe, valves, fittings, and fire hydrants in water transmission and fire protection lines. It may also be used on steel pipe (minimum thickness schedule 40) with MJ by IPS transition gasket. The RomaGrip replaces costly concrete thrust blocks, corrodible steel tie rods and clamps. Not for use on plain end mechanical joint fittings. The RomaGrip may be used on cast iron pipe as long as it has the same OD as ductile iron pipe.

Note: Some initial axial movement may occur in lug style restraints as the lugs seat. Movement is directly related to the size of the piping system and the system pressure. In general terms movement of approximately 0.25 can be expected in restraints under 16". For larger sizes, movement of approximately 0.40 may be seen. If this is critical to your application please contact Romac Engineering for additional information.

**MATERIALS**

**Gland** Ductile (nodular) iron, meeting or exceeding ASTM A 536-84, Grade 65-45-12.

**Gaskets** A standard MJ gasket is used with this fitting. See ANSI/AWWA C111/A21.11 for gasket specs.

**Restraining Bolt** 7/8 –9 roll thread, Ductile (nodular) iron, meeting or exceeding ASTM A 536-84.

**Restraining Lugs** Ductile (nodular) iron, meeting or exceeding ASTM A 536-84. Heat treated using a proprietary process.

**Lug Locators** Polyurethane, a thermo-set plastic.

**Coatings** Shop coat applied to the casting for corrosion protection in transit. Epoxy coating optional.

**PERFORMANCE**

Nominal Pipe Size	Number of Restraining Bolts	Approx. Weight (lbs)	Working Pressure (psi)	Test Pressure (psi)	Maximum Joint Deflection
3	2	6	350	700	5°
4	2	7.5	350	700	5°
6	3	11	350	700	5°
8	4	16.5	350	700	5°
10	6	23	350	700	5°
12	8	29.5	350	700	5°

**FM Approved** FM approved for cast iron and ductile iron pipe at 175 psi working pressure (4 : 1 test).

**UL Listed** UL listed for cast iron and ductile iron pipe.

Document Number 05-8-00

8/06

This information is based on the best data available at the date printed above, please check with Romac Engineering Department for any updates or changes.

**END  
OF  
SECTION**

## 9. PUMPS

This section provides the information pertaining to the pumps for this project.

This section is structured as follows:

- 9.01 PUMP SPECIFICATIONS
- 9.02 PUMP DIMENSIONAL DRAWINGS
- 9.03 PUMP PERFORMANCE CURVES
- 9.04 PUMP EXTENDED STORAGE
- 9.05 PUMP RELATED DATA SHEETS
  - 9.05.1 HUBBELL SUPPORT GRIPS
  - 9.05.2 PUMP LIFTING EYE

**EBARA Submersible Sewage Pumps**

**DLFU**

**Model Designation**

300 DLF U 6 30 4

**DISCHARGE SIZE – mm**

- 50mm – 2"      200mm – 8"
- 80mm – 3"      250mm – 10"
- 100mm – 4"     300mm – 12"
- 150mm – 6"

**MODEL TYPE**

- DLF/DLMF – submersible sewage pump
- DLFM/DLMFM – FM explosion proof designation

**GEOGRAPHIC DESIGNATION**

- U – U.S.A. market

**HERTZ**

- 6 - 60

**RATED KW**

- |            |            |           |
|------------|------------|-----------|
| 1.5 – 2HP  | 7.5 – 10HP | 22 – 30HP |
| 2.2 – 3HP  | 11 – 15HP  | 30 – 40HP |
| 3.7 – 5HP  | 15 – 20HP  | 37 – 50HP |
| 5.5 – 7½HP | 18 – 25HP  | 45 – 60HP |

**PHASE**

- none – three phase

**VOLTAGE**

- 2 - 208/230
- 4 - 460
- 5 - 575





## EBARA Submersible Sewage Pumps

## Specifications

Model DLFU  
Specifications

	Standard	Optional
Size	2, 3, 4, 6, 8, 10, 12 inch	
Range of HP	2 to 60 HP	
Range of Performance	Capacity 13 to 4000 GPM Head 7 to 243 feet	
<b>Limitation</b> Maximum Water Temperature	104°F ( 40°C)	
<b>Synchronous Speed</b>	1800 RPM	
<b>Materials</b> Casing Impeller  Shaft  Motor Frame Fastener	Cast Iron Cast Iron (2 to 60HP) Ductile Iron (150-300 DLFU 40 to 60 HP) 403 Stainless Steel (2 to 5HP) 420 Stainless Steel (7½ to 60HP) Cast Iron 304 Stainless Steel	
<b>Mechanical Seal</b> Material – Upper Side Material – Lower Side  Impeller Type  Bearing Motor Three Phase Service Factor Motor Protection  Submersible cable	Double Mechanical Seal Carbon/Ceramic (2 to 60HP) Silicon Carbide/Silicon Carbide (2 to 60HP) Tungsten Carbide/Tungsten Carbide (150-300 DLFU 50 and 60HP only) Semi-open (2 to 30HP) Enclosed (40 to 60HP) Prelubricated Ball Bearing Insulation Class F (2-5HP), H (7½ to 60HP) 208/230/460V 1.15 Thermal Detector – Klixons Mechanical Seal Leakage Detector – Float Switch 33 ft. (2 to 5HP) 50 ft. (7½ to 60HP)	Tungsten Carbide/Tungsten Carbide Tungsten Carbide/Tungsten Carbide    FM Explosion Proof, Class 1, Division 1, Group C, D   ____ ft. (customer specified)
Accessories		QDC System



**EBARA Submersible Sewage Pumps****Specifications****A. General:**

Provide submersible sewage pumps suitable for continuous duty operation underwater without loss of watertight integrity to a depth of 65 feet. Pump system design shall include a guide rail system be such that the pump will be automatically connected to the discharge piping when lowered into place on the discharge connection. The pump shall be easily removable for inspection or service, requiring no bolts, nuts, or other fasteners to be disconnected, or the need for personnel to enter the wet well. The motor and pump shall be designed, manufactured, and assembled by the same manufacturer.

**B. Manufacturer:**

EBARA International Corporation

**C. Pump Characteristics:**

Pumps shall conform to the following requirements:

Number of units	
Design flow (gpm)	
Design TDH (ft)	
Minimum shut off head (ft)	
RPM	1800
Maximum HP	
Minimum efficiency at design (%)	
Minimum power factor at design (%)	
Voltage/HZ	208/230V, 460V / 60
Phase	3

**D. Pump Construction:**

All major parts of the pumping unit(s) including casing, impeller, suction cover, wear rings, motor frame and discharge elbow shall be manufactured from gray cast iron, ASTM A-48 Class 30. Castings shall have smooth surfaces devoid of blow holes or other casting irregularities. Casing design shall be centerline discharge with a large radius on the cut water to prevent clogging. Units shall be furnished with a discharge elbow and 125 lb. flat face ANSI flange. All exposed bolts and nuts shall be 304 stainless steel. All mating surfaces of major components shall be machined and fitted with NBR O-rings where watertight sealing is required. Machining and fitting shall be such that sealing is accomplished by automatic compression of O-rings in two planes and O-ring contact is made on four surfaces without the requirement of specific torque limits. Internal and external surfaces are prepared to SPPC-VISI-SP-3-63 then coated with a zinc-chromate primer. The external surfaces are then coated with a H.B. Teneme-Tar 46H-413 Polyamide Epoxy - Coal Tar paint

**1. Impellers:**

- a. For units 2 to 5 HP, the impeller shall be radial single or multi-vane, semi-open design. It shall be dynamically balanced and shall be designed for solids handling with a long thrulet without acute turns. The inlet edge of the impeller vanes shall be angled toward the impeller periphery so as to facilitate the release of objects that might otherwise clog the pump. The 2 to 5 HP impeller design shall also include back pump out vanes to reduce the pressure and entry of foreign materials into the mechanical seal area. In addition, a lip seal shall be located behind the impeller hub to further reduce the entry of foreign materials into the seal area. Impellers shall be direct connected to the motor shaft with a slip fit, key driven, and secured with an impeller bolt. The design shall include a replaceable cast iron suction cover. The suction cover shall be designed such that it may be adjusted to maintain working clearances and hydraulic efficiencies.
- b. For units 7½ to 30 HP, the impeller shall be a mixed flow multi-vane semi-open design. It shall be dynamically balanced and shall be designed for solids handling with a long thrulet without acute turns. The inlet edge of the impeller vanes shall be angled toward the impeller periphery so as to facilitate the release of objects that might otherwise clog the pump. The 7½ to 30 HP impeller design shall also include back pump out vanes to reduce the pressure and entry of foreign materials into the mechanical seal area. In addition, a lip seal shall be located behind the impeller hub to further reduce the entry of foreign materials into the seal area. Impellers shall be direct



**EBARA Submersible Sewage Pumps****Specifications**

connected to the motor shaft with a slip fit, key driven, and secured with an impeller bolt. The design shall include a replaceable cast iron suction cover. The suction cover shall be designed such that it may be adjusted to maintain working clearances and hydraulic efficiencies.

- c. For high head units with 4" discharge, 40 to 60 HP shall have a radial multi-vane, enclosed impeller design. It shall be dynamically balanced and shall be designed for solids handling with a long thrulet without acute turns. The inlet edge of the impeller vanes shall be angled toward the impeller periphery so as to facilitate the release of objects that might otherwise clog the pump. A lip seal shall be located behind the impeller hub to reduce the entry of foreign materials into the mechanical seal area. Impellers shall be direct connected to the motor shaft with a slip fit, key driven, and secured with an impeller bolt. The design shall include a replaceable casing wear ring at the pump suction to maintain working clearances and hydraulic efficiencies.
- d. For units 6" to 12" discharge sizes, 40 to 60 HP, the impeller shall be a mixed flow multi-vane enclosed design. It shall be dynamically balanced and shall be designed for solids handling with a long thrulet without acute turns. The inlet edge of the impeller vanes shall be angled toward the impeller periphery so as to facilitate the release of objects that might otherwise clog the pump. A lip seal shall be located behind the impeller hub to reduce the entry of foreign materials into the seal area. Impellers shall be direct connected to the motor shaft with a slip fit, key driven, and secured with an impeller bolt. The design shall include a replaceable casing wear ring at the pump suction to maintain working clearances and hydraulic efficiencies.

Optional K-series design:

- e. For units 2 to 5 HP, the impeller shall be radial single or multi-vane, semi-open design. It shall be dynamically balanced and shall be designed for solids handling with a long thrulet without acute turns. The inlet edge of the impeller vanes shall be angled toward the impeller periphery so as to facilitate the release of objects that might otherwise clog the pump. The 2 to 5 HP impeller design shall also include back pump out vanes to reduce the pressure and entry of foreign materials into the mechanical seal area. In addition, a lip seal shall be located behind the impeller hub to further reduce the entry of foreign materials into the seal area. Impellers shall be direct connected to the motor shaft with a slip fit, key driven, and secured with an impeller bolt. The design shall include a replaceable cast iron suction cover. The suction cover shall contain a groove(s) perpendicular to the suction opening to disrupt fibrous solids that may otherwise become lodged between the impeller and suction cover. The suction cover shall be designed such that it may be adjusted to maintain working clearances and hydraulic efficiencies.
- f. For units 7½ to 30 HP, the impeller shall be a mixed flow multi-vane semi-open design. It shall be dynamically balanced and shall be designed for solids handling with a long thrulet without acute turns. The inlet edge of the impeller vanes shall be angled toward the impeller periphery so as to facilitate the release of objects that might otherwise clog the pump. The 7½ to 30 HP impeller design shall also include back pump out vanes to reduce the pressure and entry of foreign materials into the mechanical seal area. In addition, a lip seal shall be located behind the impeller hub to further reduce the entry of foreign materials into the seal area. Impellers shall be direct connected to the motor shaft with a slip fit, key driven, and secured with an impeller bolt. The design shall include a replaceable cast iron suction cover. The suction cover shall contain a groove(s) perpendicular to the suction opening to disrupt fibrous solids that may otherwise become lodged between the impeller and suction cover. The suction cover shall be designed such that it may be adjusted to maintain working clearances and hydraulic efficiencies.

**2. Mechanical Seals**

- a. For units 2 to 5 HP, double mechanical seals operating in an oil bath shall be provided on all units. The oil filled seal chamber shall be designed to prevent over-filling and include an anti-vortexing vane to insure proper lubrication of both seal faces. Lower face materials shall be silicon carbide, upper faces carbon vs. ceramic, NBR elastomers, and 304SS hardware. Seal system shall not rely on pumping medium for lubrication.
- b. Units 7½ to 60 HP shall be designed to include a double mechanical seal in a tandem arrangement. Each seal shall be positively driven and act independently with its own spring system. The upper seal operates in an oil bath, while the lower seal is lubricated by the oil from between the shaft and the seal faces, and in contact with



## Specifications

the pumpage. The oil filled seal chamber shall be designed to prevent over-filling and include an anti-vortexing vane to insure proper lubrication of both seal faces. Lower face materials shall be silicon carbide (tungsten carbide for 150-300 DLF 50 & 60 HP only), upper faces carbon vs. ceramic, NBR elastomers, and 304SS hardware. Seal system shall not rely on pumping medium for lubrication.

### E. Motor Construction:

The pump motor shall be an air filled induction type with a squirrel cage rotor, shell type design, built to NEMA MG-1, Design B specifications. Stator windings shall be copper, insulated with moisture resistant Class H insulation, rated for 356°F. The stator shall be dipped and baked three times in Class H varnish and heat shrunk fitted into the stator housing. Rotor bars and short circuit rings shall be manufactured of cast aluminum. Motor shaft shall be one piece AISI403 for 2 to 5 HP, AISI420 for 7½ to 60 HP, rotating on two permanently lubricated ball bearings designed for a minimum B-10 life of 60,000 hours. Motor service factor shall be 1.15 and capable of up to 20 starts per hour. The motor shall be designed for continuous duty pumping at a maximum sump temperature of 104°F. Voltage and frequency tolerances shall be a maximum 10 / 5% respectively. Motor over temperature protection shall be provided by miniature thermal protectors embedded in the windings. Mechanical seal failure protection shall be provided by a mechanical float switch located in a chamber above the seal. This switch shall be comprised of a magnetic float that actuates a dry reed switch encapsulated within the stem. Should the mechanical seal fail, liquid shall be directed into the float chamber, in which the rising liquid activates the switch opening the normally closed circuit. For units 2 to 30 HP the float body and float shall be a polypropylene material with a 316SS stopper. Units 40 HP and greater, the float switch components shall be 304SS. The motor shall be non-overloading over the entire specified range of operation and be able to operate at full load intermittently while unsubmerged without damage to the unit.

Power cable jacket shall be manufactured of an oil resistant chloroprene rubber material, designed for submerged applications. Cable shall be watertight to a depth of at least 65'. The cable entry system shall comprise of primary, secondary, and tertiary sealing methods. The primary seal shall be achieved by a cylindrical elastomeric grommet compressed between the motor cover and a 304SS washer. Secondary sealing is accomplished with a compressed O-ring made of NBR material. Compression and subsequent sealing shall preclude specific torque requirements. The system shall also include tertiary sealing to prevent leakage into the motor housing due to capillary action through the insulation if the cable is damaged or cut. The cable wires shall be cut, stripped, re-connected with a copper butt end connector, and embedded in epoxy within the cable gland. This provides a dead end for leakage through the cable insulation into the motor junction area. The cable entry system shall be the same for both the power and control cables.

### F. Guide Rail system:

Design shall include two (2) 304SS schedule 40 guide rails sized to mount directly to the quick discharge connector, QDC, at the floor of the wetwell and to a guide rail bracket at the top of the wetwell below the hatch opening, (refer to project drawings). Intermediate guide brackets are recommended for rail lengths over 15 feet.

Guide rails are not part of the pump package and shall be supplied by others.

The QDC shall be manufactured of cast iron, ASTM A48 Class 30. It shall be designed to adequately support the guide rails, discharge piping, and pumping unit under both static and dynamic loading conditions with support legs that are suitable for anchoring it to the wetwell floor. The face of the inlet QDC flange shall be perpendicular to the floor of the wetwell. The discharge flange of the QDC shall conform to ANSI B16.1 Class 125.

The pump design shall include an integral self-aligning sliding bracket. Sealing of the pumping unit to the QDC shall be accomplished by a single, linear, downward motion of the pump. The entire weight of the pump unit shall be guided to and wedged tightly against the inlet flange of the QDC, making metal to metal contact with the pump discharge forming a seal without the use of bolts, gaskets or O-rings.

A stainless steel lifting chain of adequate length for removing and installing the pump unit is recommended. The chain shall have a round link with a 2-¼" inside diameter every two feet. This link will allow for a sliding pinch bar through the link to pick the chain, more than once if necessary, at multiple intervals during pump removal and installation.



EBARA Submersible Sewage Pumps

DLFU

Dimensions

Project: \_\_\_\_\_ Model: \_\_\_\_\_ Chk'd: \_\_\_\_\_ Date: \_\_\_\_\_

Model DLFU with Quick Discharge Connector  
 250DLFU, 40 TO 60HP  
 300DLFU, 40 TO 60HP

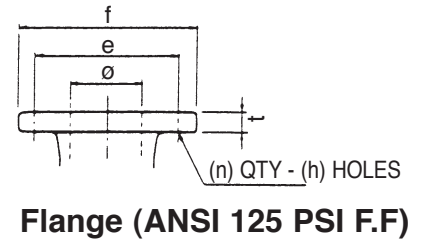
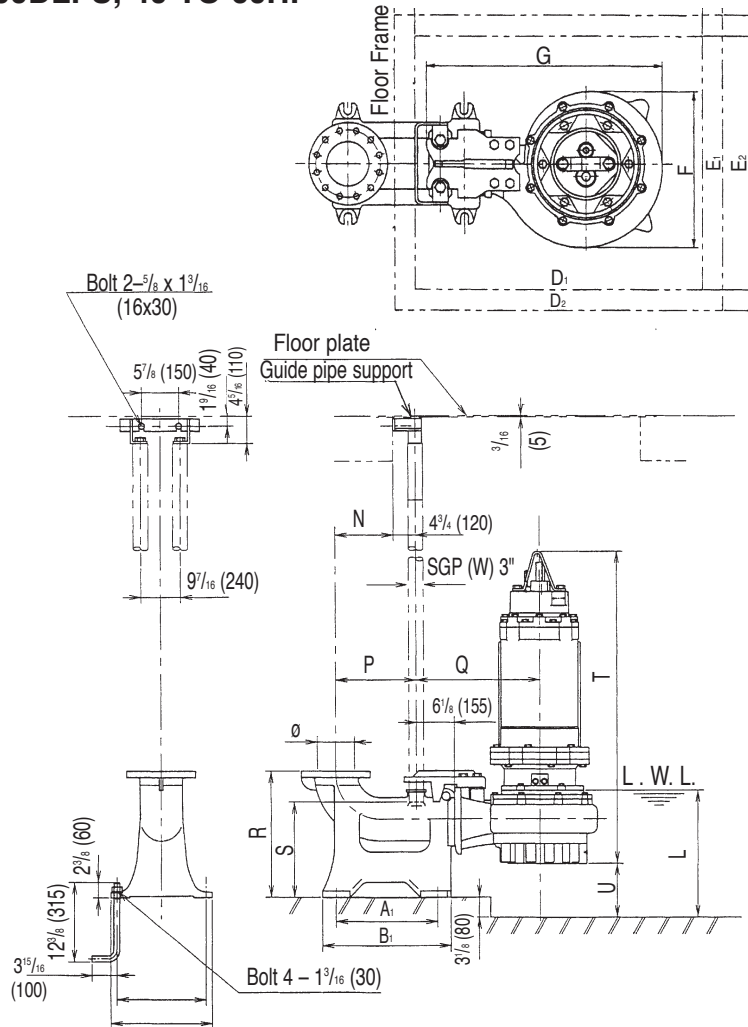

inch					
ø	e	f	t	n	h
10	14 <sup>1</sup> / <sub>4</sub>	16	1 <sup>3</sup> / <sub>16</sub>	12	1
12	17	19	1 <sup>1</sup> / <sub>4</sub>	12	1

mm					
ø	e	f	t	n	h
250	362	406	30	12	25
300	432	483	32	12	25

Dimensions: inch

PHASE	SIZE ø	MODEL	OUTPUT		QDC MODEL	PUMP & MOTOR																ACCESS HOLE				WEIGHT Lb	
			KW	HP		A <sub>1</sub>	A <sub>2</sub>	B <sub>1</sub>	B <sub>2</sub>	F	G	L	N	P	Q	R	S	T	U	D <sub>1</sub>	D <sub>2</sub>	E <sub>1</sub>	E <sub>2</sub>	PUMP	QDC		
THREE	10	250DLFU630	30	40	LL250YU	25 <sup>9</sup> / <sub>16</sub>	19 <sup>11</sup> / <sub>16</sub>	31 <sup>1</sup> / <sub>8</sub>	22 <sup>1</sup> / <sub>16</sub>	23 <sup>11</sup> / <sub>16</sub>	39 <sup>3</sup> / <sub>4</sub>	17 <sup>9</sup> / <sub>16</sub>	12 <sup>3</sup> / <sub>8</sub>	17 <sup>1</sup> / <sub>8</sub>	25	27 <sup>9</sup> / <sub>16</sub>	17 <sup>9</sup> / <sub>16</sub>	48 <sup>9</sup> / <sub>8</sub>	8 <sup>3</sup> / <sub>4</sub>	47 <sup>1</sup> / <sub>4</sub>	53 <sup>3</sup> / <sub>8</sub>	35 <sup>7</sup> / <sub>16</sub>	41 <sup>5</sup> / <sub>16</sub>	1570	344		
		250DLFU637	37	50	LL250YU	25 <sup>9</sup> / <sub>16</sub>	19 <sup>11</sup> / <sub>16</sub>	31 <sup>1</sup> / <sub>8</sub>	22 <sup>1</sup> / <sub>16</sub>	23 <sup>11</sup> / <sub>16</sub>	39 <sup>3</sup> / <sub>4</sub>	18 <sup>9</sup> / <sub>8</sub>	12 <sup>3</sup> / <sub>8</sub>	17 <sup>1</sup> / <sub>8</sub>	25	27 <sup>9</sup> / <sub>16</sub>	17 <sup>9</sup> / <sub>16</sub>	51 <sup>1</sup> / <sub>4</sub>	8 <sup>3</sup> / <sub>4</sub>	47 <sup>1</sup> / <sub>4</sub>	53 <sup>3</sup> / <sub>8</sub>	35 <sup>7</sup> / <sub>16</sub>	41 <sup>5</sup> / <sub>16</sub>	1631	344		
		250DLFU645	45	60	LL250YU	25 <sup>9</sup> / <sub>16</sub>	19 <sup>11</sup> / <sub>16</sub>	31 <sup>1</sup> / <sub>8</sub>	22 <sup>1</sup> / <sub>16</sub>	23 <sup>11</sup> / <sub>16</sub>	39 <sup>3</sup> / <sub>4</sub>	18 <sup>9</sup> / <sub>8</sub>	12 <sup>3</sup> / <sub>8</sub>	17 <sup>1</sup> / <sub>8</sub>	25	27 <sup>9</sup> / <sub>16</sub>	17 <sup>9</sup> / <sub>16</sub>	51 <sup>1</sup> / <sub>4</sub>	8 <sup>3</sup> / <sub>4</sub>	47 <sup>1</sup> / <sub>4</sub>	53 <sup>3</sup> / <sub>8</sub>	35 <sup>7</sup> / <sub>16</sub>	41 <sup>5</sup> / <sub>16</sub>	1713	344		
	12	300DLFU630	30	40	LL300YU	26 <sup>3</sup> / <sub>4</sub>	22 <sup>3</sup> / <sub>16</sub>	32 <sup>3</sup> / <sub>16</sub>	25 <sup>3</sup> / <sub>16</sub>	27 <sup>3</sup> / <sub>16</sub>	43 <sup>3</sup> / <sub>8</sub>	20 <sup>3</sup> / <sub>8</sub>	13 <sup>9</sup> / <sub>16</sub>	18 <sup>3</sup> / <sub>16</sub>	27 <sup>3</sup> / <sub>8</sub>	31 <sup>1</sup> / <sub>2</sub>	21 <sup>5</sup> / <sub>8</sub>	50 <sup>9</sup> / <sub>16</sub>	9 <sup>15</sup> / <sub>16</sub>	51 <sup>3</sup> / <sub>16</sub>	57 <sup>1</sup> / <sub>16</sub>	39 <sup>3</sup> / <sub>8</sub>	45 <sup>1</sup> / <sub>4</sub>	1733	450		
		300DLFU637	37	50	LL300YU	26 <sup>3</sup> / <sub>4</sub>	22 <sup>3</sup> / <sub>16</sub>	32 <sup>3</sup> / <sub>16</sub>	25 <sup>3</sup> / <sub>16</sub>	27 <sup>3</sup> / <sub>16</sub>	43 <sup>3</sup> / <sub>8</sub>	21 <sup>3</sup> / <sub>4</sub>	13 <sup>9</sup> / <sub>16</sub>	18 <sup>3</sup> / <sub>16</sub>	27 <sup>3</sup> / <sub>8</sub>	31 <sup>1</sup> / <sub>2</sub>	21 <sup>5</sup> / <sub>8</sub>	53 <sup>3</sup> / <sub>8</sub>	9 <sup>9</sup> / <sub>16</sub>	51 <sup>3</sup> / <sub>16</sub>	57 <sup>1</sup> / <sub>16</sub>	39 <sup>3</sup> / <sub>8</sub>	45 <sup>1</sup> / <sub>4</sub>	1795	450		
		300DLFU645	45	60	LL300YU	26 <sup>3</sup> / <sub>4</sub>	22 <sup>3</sup> / <sub>16</sub>	32 <sup>3</sup> / <sub>16</sub>	25 <sup>3</sup> / <sub>16</sub>	27 <sup>3</sup> / <sub>16</sub>	43 <sup>3</sup> / <sub>8</sub>	21 <sup>3</sup> / <sub>4</sub>	13 <sup>9</sup> / <sub>16</sub>	18 <sup>3</sup> / <sub>16</sub>	27 <sup>3</sup> / <sub>8</sub>	31 <sup>1</sup> / <sub>2</sub>	21 <sup>5</sup> / <sub>8</sub>	53 <sup>3</sup> / <sub>8</sub>	9 <sup>9</sup> / <sub>16</sub>	51 <sup>3</sup> / <sub>16</sub>	57 <sup>1</sup> / <sub>16</sub>	39 <sup>3</sup> / <sub>8</sub>	45 <sup>1</sup> / <sub>4</sub>	1876	450		

Dimensions: mm

PHASE	SIZE ø	MODEL	OUTPUT		QDC MODEL	PUMP & MOTOR																ACCESS HOLE				WEIGHT kg	
			KW	HP		A <sub>1</sub>	A <sub>2</sub>	B <sub>1</sub>	B <sub>2</sub>	F	G	L	N	P	Q	R	S	T	U	D <sub>1</sub>	D <sub>2</sub>	E <sub>1</sub>	E <sub>2</sub>	PUMP	QDC		
THREE	250	250DLFU630	30	40	LL250YU	650	500	790	560	602	1010	446	315	435	635	700	440	1229	223	1200	1350	900	1050	712	156		
		250DLFU637	37	50	LL250YU	650	500	790	560	602	1010	467	315	435	635	700	440	1314	223	1200	1350	900	1050	740	156		
		250DLFU645	45	60	LL250YU	650	500	790	560	602	1010	467	315	435	635	700	440	1314	223	1200	1350	900	1050	777	156		
	300	300DLFU630	30	40	LL300YU	680	580	820	640	693	1115	531	345	465	695	800	550	1284	253	1300	1450	1000	1150	786	204		
		300DLFU637	37	50	LL300YU	680	580	820	640	693	1115	552	345	465	695	800	550	1369	253	1300	1450	1000	1150	814	204		
		300DLFU645	45	60	LL300YU	680	580	820	640	693	1115	552	345	465	695	800	550	1369	253	1300	1450	1000	1150	851	204		

## EBARA Submersible Sewage Pumps

## Sectional View

Project:

Model:

Chk'd:

Date:

40 to 60HP

150DLFU

200DLFU

250DLFU

300DLFU

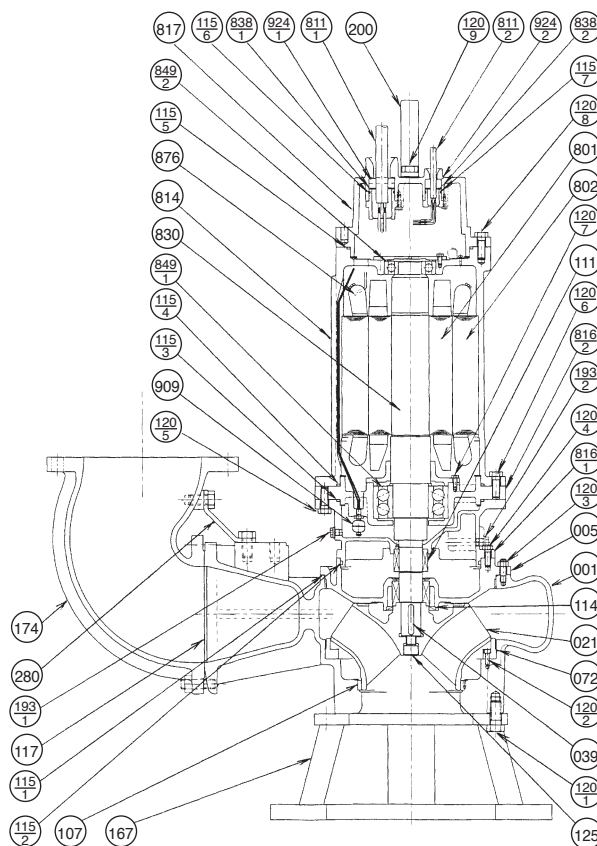

PART NO.	PART NAME	MATERIAL	ASTM, AISI CODE	NO. FOR 1 UNIT	PART NO.	PART NAME	MATERIAL	ASTM, AISI CODE	NO. FOR 1 UNIT
001	CASING	CAST IRON	A48 Class 30	1	125	BOLT	304 STAINLESS	AISI304	1
005	INTERMEDIATE CASING	CAST IRON	A48 Class 30	1	*167	BASE	STEEL	A283 Grade D	1
†021	IMPELLER	DUCTILE IRON	A536 60-40-18	1	174	DISCHARGE ELBOW	CAST IRON	A48 Class 30	1
039	KEY	420 STAINLESS	AISI420	1	193-1	PLUG	304 STAINLESS	AISI304	1
†072	SIDE RING	CAST IRON	A48 Class 30	1	193-2	PLUG	304 STAINLESS	AISI304	1
†107	WEARING RING	304 STAINLESS	AISI304	1	200	LIFTING HANGER	STEEL	A283 Grade D	1
†111	MECHANICAL SEAL	—		1 SET	280	ELBOW SUPPORT	STEEL	A283 Grade D	2
†114	OIL SEAL	RUBBER (NBR)		1	801	ROTOR	—		1
†115-1	O-RING	RUBBER (NBR)		1	802	STATOR	—		1
†115-2	O-RING	RUBBER (NBR)		1	811-1	POWER CABLE	—		2
†115-3	O-RING	RUBBER (NBR)		1	811-2	CONTROL CABLE	—		1
†115-4	O-RING	RUBBER (NBR)		1	814	MOTOR COVER	CAST IRON	A48 Class 30	1
†115-5	O-RING	RUBBER (NBR)		1	816-1	BRACKET	CAST IRON	A48 Class 30	1
†115-6	O-RING	RUBBER (NBR)		2	816-2	BRACKET	CAST IRON	A48 Class 30	1
†115-7	O-RING	RUBBER (NBR)		1	817	BRACKET	CAST IRON	A48 Class 30	1
†117	GASKET			1	830	SHAFT	420J2 STAINLESS	AISI420	1
120-1	BOLT	304 STAINLESS	AISI304	3/4	838-1	WASHER	304 STAINLESS	AISI304	2
120-2	BOLT	304 STAINLESS	AISI304	4	838-2	WASHER	304 STAINLESS	AISI304	1
120-3	BOLT	304 STAINLESS	AISI304	8	†849-1	BALL BEARING	—		1 SET
120-4	BOLT	304 STAINLESS	AISI304	4	†849-2	BALL BEARING	—		1
120-5	BOLT	304 STAINLESS	AISI304	8	876	MOTOR PROTECTOR	—		3
120-6	BOLT	304 STAINLESS	AISI304	8	909	LEAKAGE DETECTOR	—		1
120-7	BOLT	304 STAINLESS	AISI304	4	924-1	PACKING	RUBBER (NBR)		2
120-8	BOLT	304 STAINLESS	AISI304	6	924-2	PACKING	RUBBER (NBR)		1
120-9	BOLT	304 STAINLESS	AISI304	2					

Motors are purchased as a complete unit

†: Recommended spare parts

\*: Option for hard-piped installations



EBARA Fluid Handling

www.pumpsebara.com

(t) 803 327 5005 • (f) 803 327 5097

2-214

rev. 02/09



### Pump Performance Datasheet

Customer	:		Quote number	:	
Customer reference	:		Size	:	300DLFU630
Item number	:	Default	Stages	:	1
Service	:		Based on curve number	:	DLY-C610-9203
Quantity	:	1	Date last saved	:	21 Feb 2014 11:29 AM

Operating Conditions	
Flow, rated	: 3,400.0 USgpm
Differential head / pressure, rated (requested)	: 15.73 ft
Differential head / pressure, rated (actual)	: 16.02 ft
Suction pressure, rated / max	: 0.00 / 0.00 psi.g
NPSH available, rated	: Ample
Frequency	: 60 Hz

Liquid	
Liquid type	: Water
Additional liquid description	:
Solids diameter, max	: 0.00 in
Solids concentration, by volume	: 0.00 %
Temperature, max	: 68.00 deg F
Fluid density, rated / max	: 1.000 / 1.000 SG
Viscosity, rated	: 1.00 cP
Vapor pressure, rated	: 0.00 psi.a

Performance	
Speed, rated	: 1,770 rpm
Impeller diameter, rated	: 10.47 in
Impeller diameter, maximum	: 10.79 in
Impeller diameter, minimum	: 9.96 in
Efficiency	: 41.51 %
NPSH required / margin required	: - / 0.00 ft
Ns (imp. eye flow) / Nss (imp. eye flow)	: N/A US Units
MCSF	: 480.0 USgpm
Head, maximum, rated diameter	: 51.56 ft
Head rise to shutoff	: 227.79 %
Flow, best eff. point (BEP)	: 2,292.8 USgpm
Flow ratio (rated / BEP)	: 148.29 %
Diameter ratio (rated / max)	: 97.08 %
Head ratio (rated dia / max dia)	: 72.62 %
Cq/Ch/Ce/Cn [ANSI/HI 9.6.7-2010]	: 1.00 / 1.00 / 1.00 / 1.00
Selection status	: Acceptable

Material	
Material selected	: Cast Iron

Pressure Data	
Maximum working pressure	: 22.32 psi.g
Maximum allowable working pressure	: N/A
Maximum allowable suction pressure	: N/A
Hydrostatic test pressure	: N/A

Driver & Power Data	
Driver sizing specification	: Rated power
Margin over specification	: 0.00 %
Service factor	: 1.00
Power, hydraulic	: 13.51 hp
Power, rated	: 32.54 hp
Power, maximum, rated diameter	: 38.05 hp
Minimum recommended motor rating	: 40.00 hp / 29.83 kW (Fixed)

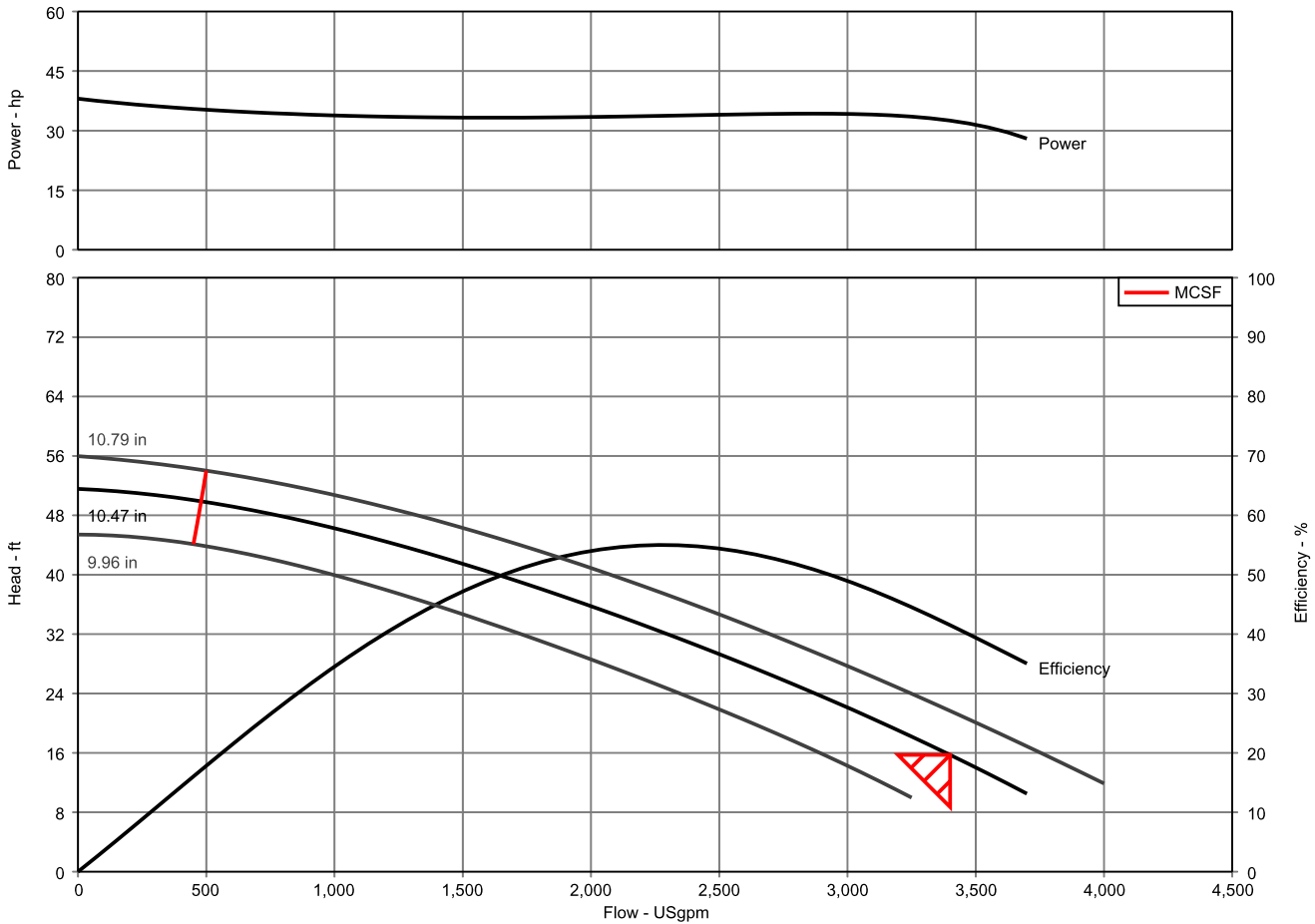

## 9.04 PUMP EXTENDED STORAGE

### Recommendations:

1. Store pumps upright in a dry location free of extreme temperatures and direct sunlight.
2. To insure that all rotating parts (seals, bearings, and impellers) are free for final installation and start-up the pump impeller should be rotated by hand every month.
3. Use silicone spray or rust inhibiting oil and spray into the lower casing completely coating the impeller and inner lower case. In addition, fully coat the discharge flange face.
4. Protect pump cables from damage and moisture. Cables should be placed so that there is no tension on the cable entry point into the pump. The free end of the cable should be protected from moisture at all times during storage and handling.
5. Never store pumps in the wet well.
6. Never lift the pump by the power cable.
7. Consult pump manufacture for further recommendations for pumps stored longer than one year.





**EBARA FLUID HANDLING**  
**1651 CEDAR LINE DRIVE**  
**ROCK HILL SC 29730**  
**803-327-5005 phone**  
**803-327-5097 fax**

## **PREPARATION FOR EXTENDED STORAGE**

Ebara pumps leave the factory properly assembled and ready to perform even after a reasonable idle time in storage. Prolonged idle time can be detrimental to any rotating machinery. Please follow the following procedures to insure pumps are in top condition to operate when installed. Whenever possible, store pumping units in a dry environment free of extreme temperatures and direct sunlight and always protect cable ends from moisture.

### **NEW PUMPS: Storage 6 to 12 months:**

When rotating equipment is left idle for long periods of time a set position tends to be established due to inaction of the moving parts. Some areas may be damaged (especially seals) from the sudden fast breakaway of start-up when stored for a long period of time. To insure that all rotating parts (seals, bearings, and impellers) are free for final installation and start-up it is good practice to rotate the impeller by hand every 30 days to insure pumps are suitable for operation. Keep cable ends covered and out of contact with moisture. **Never store pumps in wet well with cables secured to pumps.**

### **NEW PUMPS: Storage 12 to 24 months:**

In addition to the above practices use a silicone spray or rust inhibiting oil and spray into the lower casing so as to coat the impeller and lower casing. Also coat the lower casing discharge flange face.

**USED & REBUILT PUMPS:** Before storing a used or rebuilt pump for an extended amount of time, the pump should be checked for any defects. In case of a used pump dismantle and inspect for any defects and reassemble. Protect the impeller and lower casing as mentioned in above paragraph.

In all cases check all external bolts, nuts, for tightness before final installation after extended storage. This procedure is for all Ebara pumps.

PAGE IS INTENTIONALLY LEFT BLANK

## Support Grips

### Standard Duty Support

Single Eye, Single Weave, ~~Tin-Coated Bronze~~



#### Single Eye, Closed Mesh\*

For permanent support when cable end is available to be installed through grip.

Cable Diameter Range Inches (cm)	Approx. Breaking Strength Lbs. (N)	E Inches (cm)	M Inches (cm)	Catalog Numbers
.50"-.62" (1.27-1.57)	530 (2,357)	7" (17.78)	10" (25.40)	02201013
.63"-.74" (1.60-1.88)	790 (3,514)	8" (20.32)	10" (25.40)	02201014
.75"-.99" (1.90-2.51)	1,020 (4,537)	8" (20.32)	13" (33.02)	02201015
1.00"-1.24" (2.54-3.15)	1,610 (7,161)	9" (22.86)	14" (35.56)	02201017
1.25"-1.49" (3.17-3.78)	1,610 (7,161)	10" (25.40)	15" (38.10)	02201018
1.50"-1.74" (3.81-4.42)	1,610 (7,161)	12" (30.48)	17" (43.18)	02201019
1.75"-1.99" (4.44-5.05)	2,150 (9,563)	14" (35.56)	19" (48.26)	02201020
2.00"-2.49" (5.08-6.32)	3,260 (14,500)	16" (40.64)	21" (53.34)	02201021
2.50"-2.99" (6.35-7.59)	3,260 (14,500)	18" (45.72)	23" (58.42)	02201022
3.00"-3.49" (7.62-8.86)	4,900 (21,795)	21" (53.34)	25" (63.50)	02201023
3.50"-3.99" (8.89-10.13)	4,900 (21,795)	24" (60.96)	27" (68.58)	02201024

#### Single Eye, Split Mesh, Lace Closing\*

For permanent support when cable end is not available.

Cable Diameter Range Inches (cm)	Approx. Breaking Strength Lbs. (N)	E Inches (cm)	M Inches (cm)	Catalog Numbers
.50"-.62" (1.27-1.57)	530 (2,357)	7" (17.78)	10" (25.40)	02202013
.63"-.74" (1.60-1.88)	790 (3,514)	8" (20.32)	10" (25.40)	02202014
.75"-.99" (1.90-2.51)	1,020 (4,537)	8" (20.32)	13" (33.02)	02202015
1.00"-1.24" (2.54-3.15)	1,610 (7,161)	9" (22.86)	14" (35.56)	02202017
1.25"-1.49" (3.17-3.78)	1,610 (7,161)	10" (25.40)	15" (38.10)	02202018
1.50"-1.74" (3.81-4.42)	1,610 (7,161)	12" (30.48)	17" (43.18)	02202019
1.75"-1.99" (4.44-5.05)	2,150 (9,563)	14" (35.56)	19" (48.26)	02202020
2.00"-2.49" (5.08-6.32)	3,260 (14,500)	16" (40.64)	21" (53.34)	02202021
2.50"-2.99" (6.35-7.59)	3,260 (14,500)	18" (45.72)	23" (58.42)	02202022
3.00"-3.49" (7.62-8.86)	4,900 (21,795)	21" (53.34)	25" (63.50)	02202023
3.50"-3.99" (8.89-10.13)	4,900 (21,795)	24" (60.96)	27" (68.58)	02202024

#### Single Eye, Split Mesh, Rod Closing\*

For support when cable end is not available.

Cable Diameter Range Inches (cm)	Approx. Breaking Strength Lbs. (N)	E Inches (cm)	M Inches (cm)	Catalog Numbers
.50"-.62" (1.27-1.57)	790 (3,514)	7" (17.78)	8 1/2" (21.59)	02203013
.63"-.74" (1.60-1.88)	790 (3,514)	8" (20.32)	8 1/2" (21.59)	02203014
.75"-.99" (1.90-2.51)	1,020 (4,537)	8" (20.32)	10 1/2" (26.67)	02203015
1.00"-1.24" (2.54-3.15)	1,610 (7,161)	9" (22.86)	12 1/2" (31.75)	02203017
1.25"-1.49" (3.17-3.78)	1,610 (7,161)	10" (25.40)	14 1/2" (36.83)	02203018
1.50"-1.74" (3.81-4.42)	1,610 (7,161)	12" (30.48)	15 1/2" (39.37)	02203019
1.75"-1.99" (4.44-5.05)	2,150 (9,563)	14" (35.56)	16 1/2" (41.91)	02203020
2.00"-2.49" (5.08-6.32)	3,260 (14,500)	16" (40.64)	19 1/2" (49.53)	02203021
2.50"-2.99" (6.35-7.59)	3,260 (14,500)	18" (45.72)	21 1/2" (54.61)	02203022
3.00"-3.49" (7.62-8.86)	5,750 (25,576)	21" (53.34)	23 1/2" (59.69)	02203023
3.50"-3.99" (8.89-10.13)	5,750 (25,576)	24" (60.96)	25 1/2" (64.77)	02203024

F-Eye length M-Mesh length at nominal diameter

\* Change catalog number from 022 to 024 for stainless steel. Consult factory for availability.

#### IMPORTANT!

It is important that you read all breaking strength, safety and technical data relating to this product on pages T-43 through T-48.

02401015 Stainless Steel

02401017 Stainless Steel

02401018 Stainless Steel

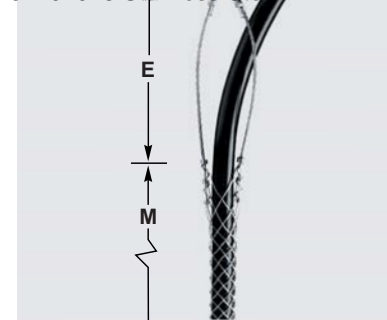

Single Eye, Closed Mesh



Single Eye, Split Mesh, Lace Closing



Single Eye, Split Mesh, Rod Closing

GRAB LINK

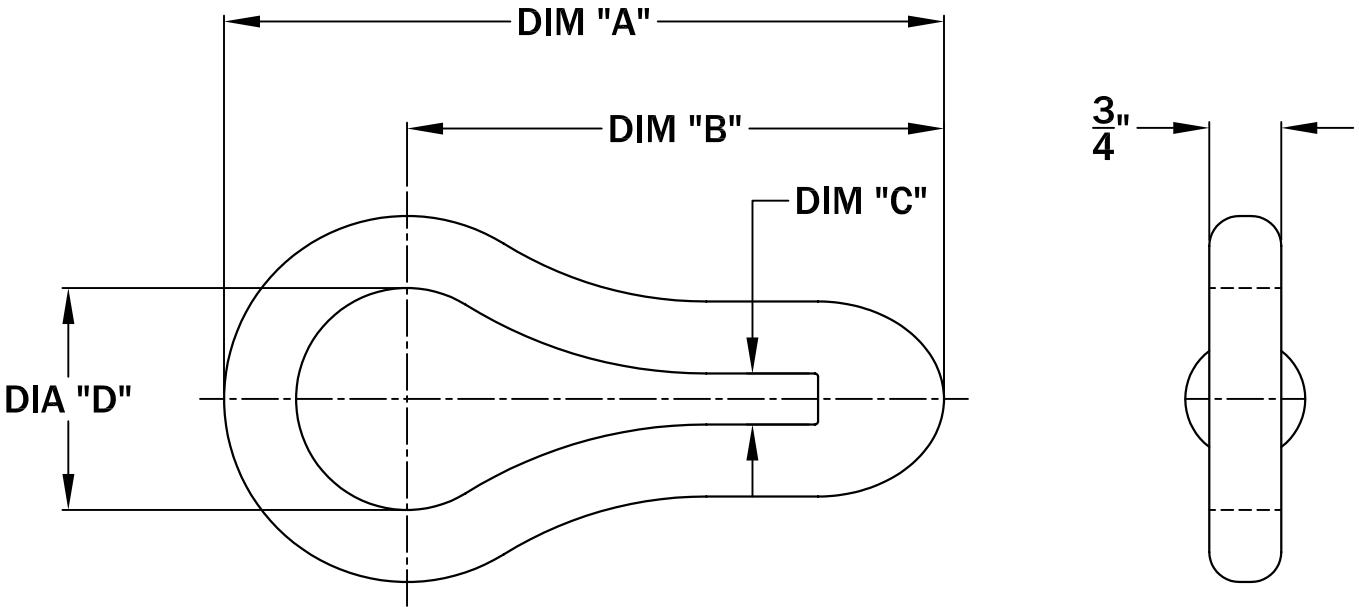

	DIM "A"	DIM "B"	DIM "C"	SAFE WORK LOAD	DIM "D"
GRABLINK	7 1/2"	5 19/32"	17/32"	6,400 Lbs	2 5/16"

ALL INFORMATION CONTAINED IN THIS DRAWING IS CONFIDENTIAL AND PROPRIETARY TO CONERY MFG, INC.



CHANGES	TOLERANCES	DRAWN BY	DATE	SPECIFICATION SHEET DIMENSIONAL DATA	
F	DECIMALS .XXX = ±.005 .XX = ±.010 FRACTIONAL X/X = ±.1/64 ANGLES X° = ±1/2°	D. MIDDLETON	01/21/08	SCALE:	PART NO.
E		MATERIAL SPECIFICATION: ALLOY STEEL		HALF	ALLOYED STEEL
D					
C					
B					
A					

**END  
OF  
SECTION**

## **10. LIQUID LEVEL SENSORS**

This section provides the information pertaining to the level sensing for this project.

This section is structured as follows:

10.01 PRIMARY LEVEL SENSOR DATA SHEETS

10.02 SECONDARY LEVEL SENSOR DATA SHEETS

# Flush Diaphragm Submersible Liquid Level Sensor



AST4520

ISO9001:2008



The AST4520 Flush Submersible Series is the cost effective solution for level monitoring of turbulent tanks with viscous media. Approved to **UL/cUL913 Class 1 Division 1 IS, Groups C and D with an approved barrier**, the product ensures a safe, reliable source for level measurement.

The AST4520 is offered with pressure ranges from 0-2.5 to 0-15 PSIG. The AST4520 steel cage front end design allows for proper flow of media while keeping the sensor at the bottom of the tank or well. With an engraved stainless steel housing and Kynar PVDF cable, this sensor is built to handle the toughest environments.

## Benefits

- Engraved 316L Housing
- Protective Steel Cage Assembly
- Kynar PVDF Cable
- Compatible with a Wide Range of Chemicals
- Ruggedly Designed for Harsh Waste Water Environments
- Suitable for Waste, Salt, Brackish, or Fresh Water Systems
- EMI/RFI and Reverse Polarity Protection
- Lightning and Surge Protection
- Competitively Priced for OEM Applications
- ABS (American Bureau of Shipping)

Approved

## Applications

- Lift Stations - Wastewater, Storm Water, Industrial Applications
- Food Tanks
- Viscous Media Tanks
- Heavy Oil

## Environmental Data

### Temperature

Operating	-40 to 85°C (-40 to 185°F)
Storage	-40 to 100°C (-40 to 212°F)

### Thermal Limits

Compensated Range	0 to 55°C (30 to 130°F)
TC Zero	<±1.5% of FS
TC Span	<±1.5% of FS

### Other

Shock	100G, 11 msec, 1/2 sine
Vibration	10G peak, 20 to 2000 Hz.
EMI/RFI Protection:	Yes
Rating:	IP-68

## Performance @ 25°C (77°F)

Accuracy*	< ±0.25% BFSL
Stability (1 year)	±0.25% FS, typical
Over Range Protection	2X Rated Pressure
Burst Pressure	5X or 1,250 PSI (whichever is less)
Pressure Cycles	> 50 Million

\* Accuracy includes non-linearity, hysteresis & non-repeatability

## Electrical Data

Output	4-20mA
Excitation	10-28VDC
Output Impedance	>10k Ohms
Current Consumption:	20mA, typical
Bandwidth	(-3dB): DC to 250 Hz
Output Noise:	-
Zero Offset:	<±1% of FS (<±4% 1PSI)
Span Tolerance:	<±2% of FS (<±4% 1PSI)
Output Load:	0-800 Ohms@10-28VDC
Reverse Polarity Protection	Yes

## Ordering Information

**AST4520** **Y** **00005** **P** **4** **X** **1** **354**

### Series Type

### Process Connection

Y= G1/2 with steel cage

### Pressure Range

Insert 5-digit pressure range code

### Pressure Unit

H= Inches H2O                      P= PSI

### Outputs

4= 4-20mA (2 wire loop powered)

### Electrical

(for wiring information visit: <http://www.astensors.com/mediacenter.php>)

X= Optional Length (see options)

### Wetted Material

1 = 316L / 304 SS / Kynar

### Options Cable Lengths:

353 = 25 ft. (7.62 m)

**354 = 50 ft. (15.24 m)**

355 = 75 ft. (22.86 m)

	Gage PSIG	Pressure Range Code	Feet of Water Column @ 4°C (approx.)
<b>AST4520</b>	0-15	00015	34.60
	0-10	00010	23.07
	0-7.5*	00208*	17.30
	<b>0-5</b>	<b>00005</b>	<b>11.53</b>
	0-2.5*	00069*	5.77

\*2.5 and 7.5 PSI Sensor must be ordered in inches of H<sub>2</sub>O.

## Dimensional Data

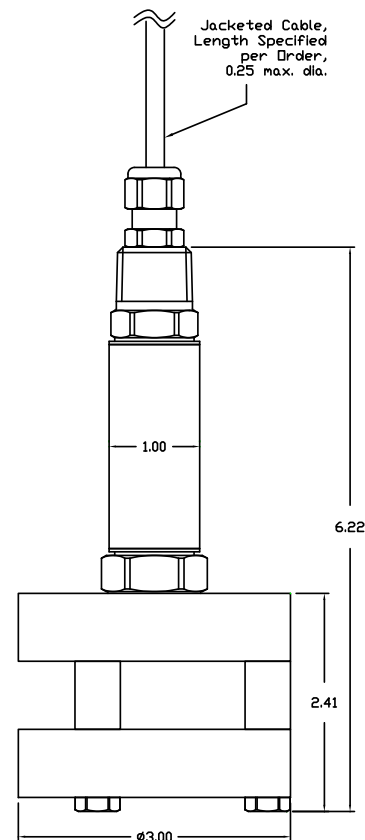

## Barrier Installation

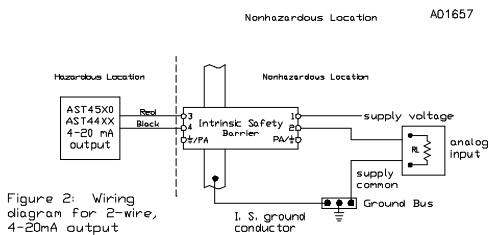

Figure 2: Wiring diagram for 2-wire, 4-20mA output

The transducers listed below are designed for installation in a Class I, Division 1, Groups C and D, Division 1 hazardous location when connected to Associated Apparatus as described in note 1.

#### Entity Parameters

$V_{max} = 28Vdc$   
 $I_{max} = 175mA$                        $I_{max}$  is the total current available from the Associated Apparatus under any condition.  
 $C_1 = 0.44\mu f$   
 $L_1 = 0$

#### Notes:

- Associated Apparatus shall provide intrinsically safe connections which meet the following parameters:  
 $V_{oc} \text{ or } V_t \leq V_{max}$                        $C_a \geq C_1 + C_{leads}$   
 $I_{sc} \text{ or } I_t \leq I_{max}$                        $L_a \geq L_1 + L_{leads}$
- Control Room apparatus shall not generate in excess of 250V ( $V_{unax}$ ).
- Installation should be in accordance with Article 504 in the National Electrical Code, ANSI/NFPA 70.

For warranty information, please visit: [www.astensors.com](http://www.astensors.com)





The NIVA level controller MS 1 is the ideal solution to control liquid levels with limited switching space, e. g. in:

- Pump stations
- Wells
- Pump chambers



The NIVA level controller MS1 is engineered especially for use in sewage works and pumping stations in liquids heavily charged with solid matter such as raw sewage etc. Thanks to the good chemical and thermal properties our level controllers are resistant to lees, uric acid, fecal sewage water, oils, petrol, diesel oil, emulsions, alcohol, fruit acids, and even many chemicals. For use at temperatures up to 80 °C (176 °F). The MS 1 has been submitted for UL certification. Optionally the level controller MS 1 is available with EX-certificate in accordance with EC directive 94/9 (ATEX 95) – see next pages.

### Available versions:

Type	Cable	Lenght (m)	Order-no.
W	TPR/PVC 3 x 0.75	5	40 000105
W	TPR/PVC 3 x 0.75	10	40 000110
W	TPR/PVC 3 x 0.75	20	40 000120
W	TPR/PVC 3 x 0.75	30	40 000130

W = Changeover (SPDT)

Other cable types and lengths are available upon request

### Application:

For use in municipal, industrial, commercial and domestic applications.

### Electronic connection

Connection of level controllers	Wire		
	grey	black	brown
For emptying a tank	insulate	X	X
For filling a tank	X	insulate	X
Alarm high level	insulate	X	X
Alarm low level	X	insulate	X

Technical data subject to change

### Technical data:

Specific weight: 0.95–1.05 or according to specification  
 Max. temperature: 80 °C (176 °F)  
 Breaking capacity: 1 mA / 4 V - 5 A / 250 V \*  
 Switch point: 10°  
 Protective system: IP 68 / 2 bar  
 Equipment group: II  
 Cable cross section: 3 x 0.75 mm<sup>2</sup>  
 Height / diameter: 180 / 100 mm (7 in / 3.9 in)  
 Housing quality: Polypropylene (PP)  
 Housing Colour: Orange  
 Cable quality: TPR/PVC  
 Cable colour: Orange

\* Micro-switch with gold-plated contacts especially for low currents in electronic circuits

# MS 1

CE  
73/23/EEC



1mA/4V-5A/250V

☐ ⚡ +++ μ T80  
γ 0,95 - 1,05

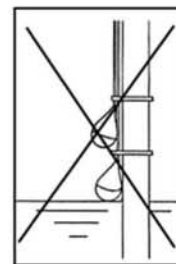
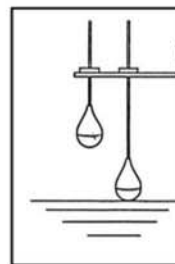

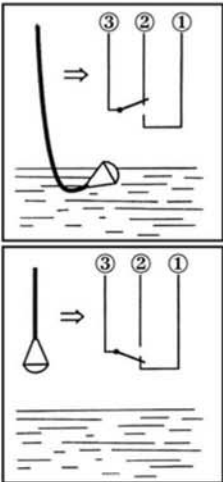
<p>                     (GB) Connection of Level Regulators                      (D) Anschluss der Niveauregler                      (F) Branchement des régulateurs de niveau                      (I) Collegamento regolatori di livello                      (E) Conexión de los reguladores de nivel                      (P) Conexão dos reguladores de nível                      (NL) Aansluiting van de niveauregelaar                      (DK) Tilslutning af niveauregulator                      (S) Anslutning av nivåregulatorn                      (N) Forbindelse til nivåregulatoren                      (FIN) Pinnansäätimien liittäminen                      (RUS) подсоединение регулятора уровня                      (PL) Przyłącze regulatorów poziomu                      (H) A szintszabályozók csatlakoztatása                      (CZ) Připoj regulátorů hladiny                      (SK) Pripoj regulátorov hladiny                      (SL) Priključitev regulatorjev nivoja                      (HR) Cijev za regulator razine                      (SC) Cev za spravu za regulisanje nivoa                      (GR) Σύνδεση ρυθμιστή στάθμης                      (TR) Seviye regülatörlerinin bağlanması                 </p>		<p>                     ①                      grey                      grau                      gris                      grigio                      gris                      cinzento                      grijs                      grå                      grå                      grå                      harmaa                      серый                      kolor szary                      szürke                      šedý                      sivý                      siv                      sivo                      sivo                      γκριζο                      gri                 </p>	<p>                     ②                      black                      schwarz                      noir                      nero                      negro                      preto                      zwart                      sort                      svart                      svart                      musta                      чёрный                      kolor czarny                      fekete                      černý                      černý                      črno                      crni                      crni                      μαύρο                      siyah                 </p>	<p>                     ③                      brown                      braun                      brun                      marrone                      marrón                      castanho                      bruin                      brun                      brun                      brun                      ruskea                      коричневый                      kolor brązowy                      barna                      hnědý                      hnedý                      rjavo                      smeđi                      smeđi                      καφέ                      kahverengi                 </p>
<p>                     (GB) For emptying a tank                      (D) Zum Entleeren eines Behälters                      (F) Pour vider un réservoir                      (I) Per lo svuotamento                      (E) Para vaciar un recipiente                      (P) Para esvaziar um reservatório                      (NL) Om een reservoir te legen                      (DK) Til tømning af en beholder                      (S) För tömning av en behållare                      (N) For å tomme en beholder                      (FIN) Säiliön tyhjentämiseen                      (RUS) для опорожнения резервуара                      (PL) Opróżnienie pojemnika                      (H) Egy tartály ürítéséhez                      (CZ) K vyprázdnění nádrže                      (SK) K vyprázdneniu nádrže                      (SL) Za praznjenje posode                      (HR) Za praznjenje nekog spremnika                      (SC) Za praznjenje nekog rezervoara                      (GR) Για την εκκένωση των περιέκτη                      (TR) Bir hazneyi/kabi boşaltmak için                 </p>	<p>                     Alarm high level                      Alarm bei hohem Flüssigkeitsstand                      Alarme au niveau supérieur                      Allarme di massimo livello                      Alarma con alto nivel de líquido                      Alarme de nível máximo                      Alarm bij een hoog vloeistofpeil                      Alarm ved høj væskeneiveau                      Larm vid hög vätskenivå                      Alarm ved høyt væskeneivå                      Ylärajahälytys                      сигнал тревоги при высоком уровне жидкости                      Alarm w przypadku wysokiego poziomu cieczy                      Riasztás túl magas töltésszint esetén                      Poplach při vysokém stavu kapaliny                      Poplach pri vysokom stave kvapaliny                      Alarm pri visokem nivoju tekočine                      Alarm kod visokog stanja tekućine                      Alarm kod visokog stanja tečnosti                      Αλάρμ σε πολύ υψηλή στάθμη υγρού                      Yüksek sıvı seviyesinde alarm                 </p>	<p>                     insulate                      isolieren                      isoler                      isolare                      aislar                      isolar                      isoleren                      isoler                      isolera                      isolere                      eristä                      изолировать                      zaizolować                      szigeteljük                      izolovat                      izolovat'                      izolirati                      izolirati                      izolovati                      μόνωση                      izole etmek                 </p>	<p>X</p>	<p>X</p>
<p>                     (GB) For filling a tank                      (D) Zum Füllen eines Behälters                      (F) Pour remplir un réservoir                      (I) Per il riempimento                      (E) Para llenar un recipiente                      (P) Para encher um reservatório                      (NL) Om een reservoir te vullen                      (DK) Til fyldning af en beholder                      (S) För fyllning av en behållare                      (N) For å fylle en beholder                      (FIN) Säiliön täyttämiseen                      (RUS) для наполнения резервуара                      (PL) Napełnienie pojemnika                      (H) Egy tartály töltéséhez                      (CZ) K naplnění nádrže                      (SK) K naplneniu nádrže                      (SL) Za polnjenje posode                      (HR) Za punjenje nekog spremnika                      (SC) Za punjenje nekog rezervoara                      (GR) Για την πλήρωση των περιέκτη                      (TR) Bir hayneyi/kabi doldurmak için                 </p>	<p>                     Alarm low level                      Alarm bei niedrigem Flüssigkeitsstand                      Alarme au niveau inférieur                      Allarme di minimo livello                      Alarma con bajo nivel de líquido                      Alarme de nível mínimo                      Alarm bij een laag vloeistofpeil                      Alarm ved lav væskeneiveau                      Larm vid låg vätskenivå                      Alarm ved lavt væskeneivå                      Alarajahälytys                      сигнал тревоги при низком уровне жидкости                      Alarm w przypadku niskiego poziomu cieczy                      Riasztás túl alacsony töltésszint esetén                      Poplach při nízkém stavu kapaliny                      Poplach pri nízkom stave kvapaliny                      Alarm pri nizkem nivoju tekočine                      Alarm kod niskog stanja tekućine                      Alarm kod niskog stanja tečnosti                      Αλάρμ σε πολύ χαμηλή στάθμη υγρού                      Düşük sıvı seviyesinde alarm                 </p>	<p>X</p>	<p>                     insulate                      isolieren                      isoler                      isolare                      aislar                      isolar                      isoleren                      isoler                      isolera                      isolere                      eristä                      изолировать                      zaizolować                      szigeteljük                      izolovat                      izolovat'                      izolirati                      izolirati                      izolovati                      μόνωση                      izole etmek                 </p>	<p>X</p>

**END  
OF  
SECTION**

## 11. ELECTRICAL INTERCONNECTIONS

This section includes data and drawings for typical field wiring.

11.01 TYPICAL FIELD WIRING PLAN

11.02 ELECTRICAL INSTALLATION RECOMMENDATIONS

11.03 PUMP CABLE INSPECTION AND INSTALLATION RECOMMENDATIONS

### **IMPORTANT!**

Romtec Utilities has not produced site electrical drawings. Any site electrical drawings in this Scope of Supply and Design Submittal have been produced by others. Romtec Utilities has not checked the site electrical drawings for their accuracy.

**Romtec Utilities makes no claim as to the accuracy of information contained in these site electrical drawings.**

The typical field wiring plan is only a suggestion by Romtec Utilities. Receiving final approval of the field wiring on the approved site plan and/or site electrical drawings is the responsibility of the Customer or the Customer's representative.

**Romtec Utilities makes no claim as to the suitability of the typical field wiring plan for the project.**

### **IMPORTANT!**

Romtec Utilities does not provide cored holes into the wet well for electrical conduit ports or conduit runs. The electrically related cored holes into the wet well are the responsibility of the contractor and electrician.

Wet well electrically related cored holes' final size, orientation, height and number are best determined after installation of the wet well and other electrical components.





## 11.02 ELECTRICAL INSTALLATION RECOMMENDATIONS

The following information is a recommendation only. It is the responsibility of the installing electrical contractor to review all as-built system information and make the installation as per the National Electrical Code (NEC).

Install all electrical conduits in accordance with the NEC, or as shown, whichever is greater.

Install all branch circuit and feeder conductors in accordance with the NEC, or as shown, whichever is greater.

Install all branch circuit and/or feeder overcurrent protection devices in accordance with the NEC.

<b>Lift Station Control Panel (LCP)</b>							
Volts	480		Largest HP	40		SCCR Rating	5KA
Phase	3 PH		Largest FLA	49.5			
Frequency	60 HZ		Total FLA	116.58			



## 11.02 ELECTRICAL INSTALLATION RECOMMENDATIONS

<i>Recommended Conduit Sizes</i>				
<b>Device</b>	<b>HP</b>	<b>Power Dia.</b>	<b>Control Dia.</b>	<b>Conduit Size</b>
<i>Pump 1</i>	<i>40</i>	<i>2 x 1.1</i>	<i>.49</i>	<i>3"</i>
<i>Pump 2</i>	<i>40</i>	<i>2 x 1.1</i>	<i>.49</i>	<i>3"</i>
<i>Pressure Transducer</i>			<i>.38</i>	<i>1"</i>
<i>Floats</i>			<i>.25</i>	

**Note:** All conduit calculations based on rigid metal conduit (RMC) @ 40% maximum fill as per the 2011 National Electrical Code.

Size all conduits in accordance with the NEC, or as recommended, whichever is greater.

**Special Note:** The above information is preliminary information only. It is the installing contractor's responsibility to reference the as-built documentation to verify all information and to confirm that the installation meets the requirements of the National Electrical Code and any local code requirements.

### **Further Recommendations:**

Where the NEC allows, use schedule 40 PVC for all conduits installed underground. Use a long radius rigid steel conduit elbow and rigid steel conduit for transition to above grade terminations. PVC conduit shall not be exposed. All below grade rigid steel conduit shall be PVC coated, half-lap wrapped with corrosion protection tape, or coated with corrosion protection paint.

## 11.03 PUMP CABLE INSPECTION AND INSTALLATION RECOMMENDATIONS

### Recommendations:

1. Inspect the full length of the pump cable for any signs of damage which may include abrasions, cuts, crushed insulation, and signs of moisture entry.
2. If cable damage is found, further testing of the cable and its overall integrity will need to be performed by a qualified technician.

**Note:** *A high percentage of cable failures are due to mechanical damage, which typically occurs during transportation, handling and installation.*

3. When cables are installed in a raceway, underground electrical duct or cable tray, the following factors should be considered.
  - a. Cable configuration
  - b. Raceway or cable tray fill
  - c. Physical limitations of cables
  - d. Installation equipment
  - e. Ambient temperature and conditions

**Note:** *Low temperatures are a cause for concern when installing cables.*

4. Prior to performing a low temperature (less than 10°F) cable installation, cables should be pre-conditioned by storing for a minimum of 24 hours at a temperature of 55°F or higher.
5. Do not impact, drop, kink or bend cable sharply in low temperatures.
6. All cables to be installed in a raceway shall be pulled together. They should be trained and guided into the raceway using an approved pulling compound or lubricant when necessary.
7. Conduits shall be cleaned prior to installing cables to ensure that the outer jacket is not damaged.
8. Pump cables shall be supported vertically in the wet well by stainless steel wire mesh support grips sized for the application.

**11.03****PUMP CABLE INSPECTION AND  
INSTALLATION RECOMMENDATIONS**

9. All hardware including fittings, hangers, supports, and fasteners shall have corrosion protection suitable for the atmosphere.
10. Conduit bushing shall be installed where required to prevent cable damage.
11. Pump cables shall be installed in the wet well with adequate length to allow for removal of the pumps without disconnecting the cables.
12. Extra cable length shall be secured so as not to interfere with pump intake.

**END  
OF  
SECTION**

## **12. CONTROL PANEL & COMMUNICATIONS**

This section includes design and data pertinent to the control panel and electrical communication.

This section is structured as follows:

12.01 STANDARD TEMPERATURE SPECIFICATIONS

12.02 POWER QUALITY DISCLAIMER

12.03 ELECTRICAL SYSTEM DESIGN VOLTAGE

12.04 SPECIFICATIONS – CONTROL PANEL SCOPE OF SUPPLY

12.05 ONE-LINE DRAWING

## 12.01

## STANDARD TEMPERATURE SPECIFICATIONS

### Standard Temperature Specifications for Electrical Control Panels Without VFDs:

Operating Temperature Ranges Tmin <sup>1</sup> All = -5°F (-20C)	NEMA 4 Painted Gray	NEMA 4 Painted White	NEMA 4X Stainless Steel	NEMA 3R With Fans
Direct Sun Exposure	Tmax 96°F (35.6°C)	Tmax 109°F (42.8°C)	Tmax 106°F (41.1°C)	Tmax 118°F (41.1°C)
No Sun Exposure (Completely Shaded)	Tmax 109°F (42.8°C)	Tmax 109°F (42.8°C)	Tmax 109°F (42.8°C)	Tmax 120°F (42.8°C)
Direct Sun Exposure Air Conditioned Enclosure	Tmax 112°F (44.4°C)	Tmax 122°F (50°C)	Tmax 118°F (47.8°C)	Not Applicable

1. If lower temperature ranges are required a larger than standard heater can be added at additional cost.
2. If higher temperature ranges are required an air conditioner unit can be added at additional cost.

### Application Notes Regarding Temperature:

- Romtec Utilities recommends adding sunshades to all enclosure installations.
- Direct sunlight doubles heat loading in gray painted cabinets as reflected in the above temperature specifications. Romtec Utilities does not recommend using gray painted cabinets in direct sunlight applications.
- Where large temperature swings (less than -5°F to greater than 96°F) are common, consider purchasing a Romtec Utilities shelter or building.
- The above operating temperatures do not reflect cabinets containing VFDs. When VFDs are required the Romtec Utilities suggested enclosure is NEMA 3R with fans. Romtec Utilities can accommodate other VFD enclosure configurations but this will require full design analysis including expected site temperature ranges provided by the customer.
- Romtec Utilities will not warranty panels that are operating outside of the stated temperature ranges.
- Panels that are partially shaded fall into the Direct Sun Exposure temperature ranges listed above. Romtec Utilities cannot quantify the effect of partial shading related to temperature performance.
- Designs do not include air-conditioning unless specifically requested.

### **Power Quality**

Poor power quality can have an adverse effect on the control system operation and reliability. In addition, pump motors can be damaged by sustained application of unbalanced phase voltages and/or balanced phase voltages operating above or below normal nameplate ratings.

Romtec Utilities recommends that the supply voltage to the Romtec Utilities control panel comply with the National Equipment Manufacturers Association ( NEMA) Standard MB1-1987-SECTION 14.34B. Any performance issues that arise as a result of the supply voltage not meeting these standards are the responsibility of the owner. Romtec Utilities is not responsible for identifying or mitigating any power quality issues that are result of power quality associated with the utility supply voltage.

### **NEMA Published Tolerances**

Voltage imbalance not to exceed 1% measured at the motor terminals

Current imbalance not to exceed 5% measured at the motor terminals

Voltage levels not to exceed +/- 10% name plate rating.

## 12.03 ELECTRICAL SYSTEM DESIGN VOLTAGE



5/5/13

INDIAN SPRINGS  
SANTA ROSA, CA

### **Electrical System Design Voltage**

This system has been designed to operate on 480V, 3 Phase supplied power.

Please verify that this is the correct voltage configuration available on-site.



## 12.04 CONTROL PANEL SCOPE OF SUPPLY



### Control Panel Scope of Supply 5/5/13 INDIAN SPRINGS SANTA ROSA, CA

#### General information

- ELECTRICAL SERVICE - 480V, 3 Phase
- PUMPS - (2) 40HP, 460V, 3 PH, 49.5FLA, DUPLEX configuration
- PUMPS - MODEL EBARA , 300DLFU630
- PRIMARY CONTROLLER - PUMP CONTROLLER 3000 configured for DUPLEX
- PANEL MOUNTING - FLOOR MOUNTED
- DEVICE MOUNTING - INNER SWING PANEL

#### Liquid level sensing

- PRIMARY LEVEL SENSING - AST4520 TRANSDUCER WIRED FOR INTRINSICALLY SAFE
- BACKUP LEVEL SENSING - (2) NOLTA FLOATS WIRED FOR INTRINSICALLY SAFE

#### Station Control Panel

Qty.	Description
1	NEMA 4 PAINTED STEEL, 62"H X 48"W X 12"D enclosure, 3 point padlocking latch.
1	12" Leg Kit
1	Controls are mounted on inside dead front swing door
1	Phase / Voltage Monitoring device to detect incoming power to the pump station and prevent the pumps from running if a voltage problem exists. This device shall be protected by a monitoring circuit breaker.
1	Transient Voltage Surge Suppression device to protect controls and associated equipment.
2	Pump motor circuit breakers, operable directly through dead front. Capable of being individually locked in the off position.
2	Soft Starters w/keypads mounted on inner swing panel.
1	1500VA Control power transformer
1	Primary pump control of type PC 3000 configured for DUPLEX alternation. <ul style="list-style-type: none"><li>- Alternation switch to turn alternation on and to select the lead pump if alternation is turned off.</li><li>- Numeric display for dynamic level, status, and setpoint information</li><li>- Pump run indicators</li><li>- Transducer fault indicator</li><li>- High level indicator</li><li>- Low level indicator</li><li>- Elapsed time meter for each pump</li></ul>
2	HAND-OFF-AUTO switches for operation of the pump station in conjunction with liquid level indications

- 2 Pump cycle counters
- 2 Pump reset push-buttons mounted on inner swing panel.
- 2 Pump running pilot lights mounted on inner swing panel.
- 2 Pump monitoring relays for Ebara pumps
- 1 Control transformer to generate a 120V control Bus.
- 1 A caged flashing alarm beacon for local alarm notification
- 1 Enclosure heater and thermostat if low Ambient temperature is below 40 degrees F
  
- 1 There will be separate circuit breakers mounted on the operator interface to control the following functions:
  - 1. Convenience outlet 3A
- 1 IS Barrier for connection to level sensing floats
- 1 IS Barrier for connection to level sensing pressure transducer

System Inputs to the terminal strip will be as follows

**6 Dry Contacts**

- TO1 Pump 1 Run
- TO2 Pump 2 Run
- TO3 Pump 1 Fault
- TO4 Pump 2 Fault
- TO5 High Level Alarm
- TO6 Power Fail

① INCOMING POWER  
480V/ 3PH/ SERVICE

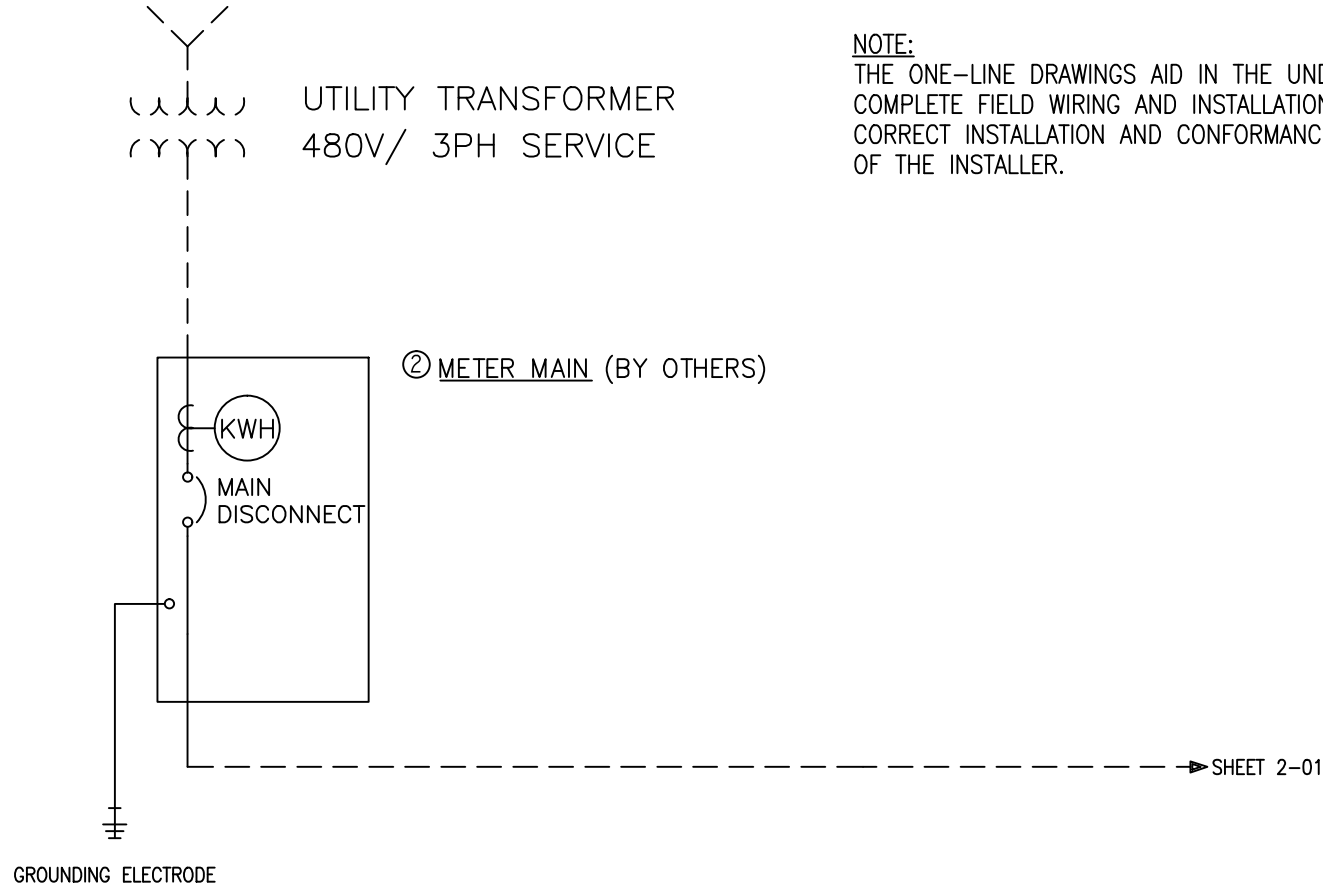

NOTE:  
THE ONE-LINE DRAWINGS AID IN THE UNDERSTANDING AND INSTALLATION OF THE CONTROL SYSTEM. COMPLETE FIELD WIRING AND INSTALLATION INSTRUCTIONS ARE NOT INCLUDED HERE. THE CORRECT INSTALLATION AND CONFORMANCE TO ALL APPLICABLE CODES IS THE RESPONSIBILITY OF THE INSTALLER.

EMERGENCY POWER BACK-UP SYSTEM:  
AN EMERGENCY POWER BACK-UP SYSTEM HAS NOT BEEN SPECIFIED BY ROMTEC UTILITIES FOR THIS PROJECT.

SHEET  
1 OF 4

NO.	DATE	DESCRIPTION	BY
1			

E0106D03

DSN: K.A.S  
DRN: K.A.S  
CKD: K.A.S  
8/5/13

© ROMTEC, INC. ALL RIGHTS RESERVED. THESE PLANS AND DRAWINGS MAY NOT BE REPRODUCED, ADAPTED, COPIED, FURTHER DISTRIBUTED, AND NO COMPONENTS MAY BE CONSTRUCTED FROM THESE PLANS, WITHOUT WRITTEN PERMISSION OF ROMTEC, INC.

**ROMTEC UTILITIES**  
18240 NORTH BANK ROAD  
ROSEBURG, OR 97470  
(541)-496-9678  
FAX (541)-496-0804  
WWW.romtecutilities.com

INDIAN SPRINGS STORMWATER  
SANTA ROSA, CA  
DUPLEX LIFT STATION SYSTEM  
ONE LINE DIAGRAM  
DRAWING

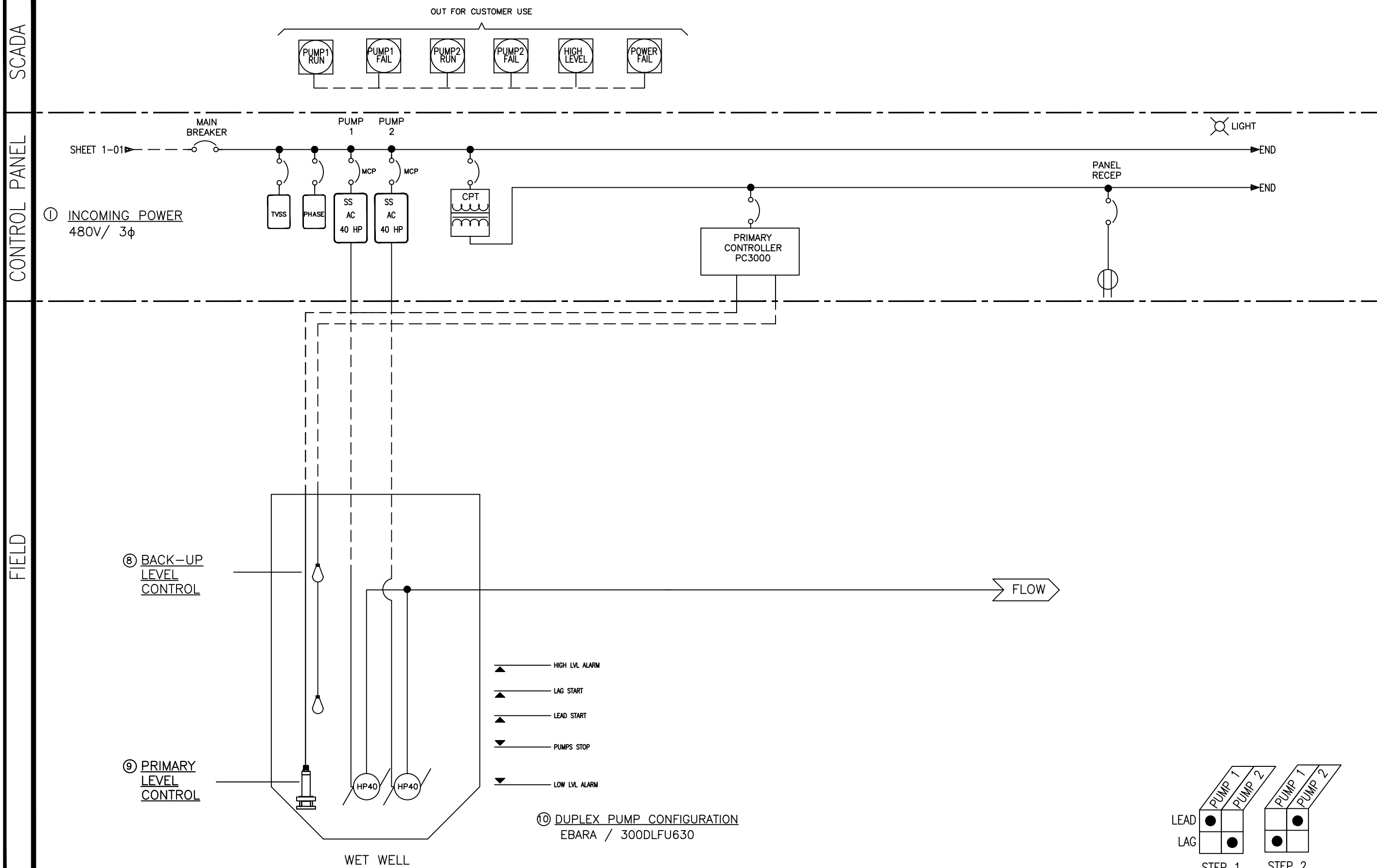

① INCOMING POWER  
480V/ 3φ

⑧ BACK-UP  
LEVEL  
CONTROL

⑨ PRIMARY  
LEVEL  
CONTROL

⑩ DUPLEX PUMP CONFIGURATION  
EBARA / 300DLFU630

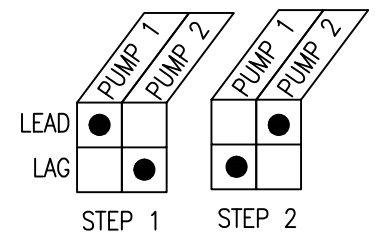

E0106003

DSN: KAS  
DRN: KAS  
CKD: KAS  
REV: 1  
DATE: 8/27/13

© ROMTEC INC. ALL RIGHTS RESERVED. THESE PLANS AND DRAWINGS MAY NOT BE REPRODUCED, ADAPTED, OR FURTHER DISTRIBUTED, AND NO COMPONENTS MAY BE CONSTRUCTED FROM THESE PLANS, WITHOUT WRITTEN PERMISSION OF ROMTEC, INC.

**ROMTEC UTILITIES**  
 18240 NORTH BANK ROAD  
 ROSEBURG, OR 97470  
 (541)-496-9678  
 FAX (541)-496-0804  
 WWW.romtecutilities.com

INDIAN SPRINGS STORMWATER  
 SANTA ROSA, CA  
 DUPLEX LIFT STATION SYSTEM  
 ONE LINE DIAGRAM  
 DRAWING

GENERAL NOTES:

1. THE ELECTRICAL CONTRACTOR SHALL SUPPLY POWER TO AND MAKE ALL CONNECTIONS TO THE EQUIPMENT SHOWN ON THE ELECTRICAL ENGINEER'S ELECTRICAL SITE PLAN. IT SHALL BE THE RESPONSIBILITY OF THE ELECTRICAL CONTRACTOR TO REVIEW ALL THE DRAWINGS FOR THE LOCATION AND SIZE OF EQUIPMENT. IT SHALL BE THE RESPONSIBILITY OF THE ELECTRICAL CONTRACTOR TO FAMILIARIZE HIM/HERSELF WITH THE PLANS AND SPECIFICATIONS AND ASK FOR CLARIFICATION, IF ANY IS REQUIRED, BEFORE INSTALLATION BEGINS.
2. THE ELECTRICAL CONTRACTOR SHALL SUPPLY THE INCOMING POWER.
3. ALL ITEMS RELATED TO THE ELECTRICAL SERVICE SUCH AS SERVICE CONDUIT, CONDUCTORS, DUCTS, PAD MOUNT, RISERS, PULL BOXES, PERMITS, FEES, AND PROTECTIVE COVERING FROM THE SERVICE POINT LOCATION SHALL BE VERIFIED WITH THE SERVING UTILITY. THE ELECTRICAL CONTRACTOR SHALL INSTALL THE SERVICE IN COMPLIANCE WITH THE SERVING UTILITY, NATIONAL ELECTRICAL CODE, STATE AND LOCAL ELECTRICAL CODES.
4. THE ELECTRICAL CONTRACTOR SHALL SUPPLY AND INSTALL THE METER BASE AND MEANS OF MAIN DISCONNECT ( A METER MAIN IS THE PREFERRED EQUIPMENT).
5. THE ELECTRICAL CONTRACTOR SHALL SUPPLY AND INSTALL ALL REQUIRED CONDUIT AND WIRE TO CONNECT TO THE ROMTEC UTILITIES SUPPLIED EQUIPMENT.
6. IT SHALL BE THE ELECTRICAL CONTRACTOR'S RESPONSIBILITY TO SIZE AND INSTALL ALL CONDUIT AND CONDUCTORS AS PER THE ELECTRICAL ENGINEER'S ELECTRICAL SITE PLAN, NEC, STATE AND LOCAL ELECTRICAL CODES.
7. INSTALLATION OF EQUIPMENT INCLUDING ANY GROUNDING ARRANGEMENT TO BE IN ACCORDANCE WITH NEC ARTICLES 501, 502, 504 AND ANSI/ISA-RP12.06.01-2003 RECOMMENDED PRACTICE FOR WIRING METHODS FOR HAZARDOUS (CLASSIFIED) LOCATIONS INSTRUMENTATION WHEN APPLICABLE.

ELECTRIC NOTES:

1. INCOMING POWER  
480V THREE PHASE POWER
2. METER MAIN  
POWER UTILITY METER BASE AND METHOD OF MAIN DISCONNECT. METER BASE MUST CONFORM TO THE LOCAL SERVICE PROVIDERS REQUIREMENTS. PROVIDE METHOD OF MAIN DISCONNECT, (A METER MAIN IS PREFERRED).  
MOUNTED AS A SEPARATE ENCLOSURE IN COMPLIANCE WITH NEC, STATE, AND LOCAL ELECTRICAL CODES.
3. AUTOMATIC TRANSFER SWITCH  
N/A

4. GENERATOR  
N/A
5. LIFT STATION CONTROL PANEL  
POWER CONFIGURATION:  
THREE PHASE INCOMING POWER  
DUPLEX PUMP CONTROL PANEL  
PRIMARY CONTROLLER:  
- ALTERNATOR PC3000  
  
BACK-UP LEVEL AND PUMP CONTROLLER:  
- NOLTA FLOATS  
  
CONTROL PANELS ARE UL LISTED AS A COMPLETE CONTROL PANEL ENCLOSURE:  
- NEMA 4 ENCLOSURE  
- 12" LEG KIT.  
- FLOOR MOUNT  
  
OPTIONAL EQUIPMENT:  
BEACON  
DRY CONTACTS FOR CUSTOMER USE  
----
6. COMMUNICATIONS  
N/A
7. PUMP DISCONNECT PANEL  
N/A

SHEET	
3	OF 4
	BY
	DESCRIPTION
	REVISIONS
	REV DATE
	1
	8/5/13
	DSN. KAS
	DRN. KAS
	CHK. KAS
	E0108003
<small>© ROMTEC INC. ALL RIGHTS RESERVED. THESE PLANS AND DRAWINGS MAY NOT BE REPRODUCED, ADAPTED, OR FURTHER DISTRIBUTED, AND NO COMPONENTS MAY BE CONSTRUCTED FROM THESE PLANS, WITHOUT WRITTEN PERMISSION OF ROMTEC, INC.</small>	
	
18240 NORTH BANK ROAD ROSEBURG, OR 97470 (541)-496-9678 FAX (541)-496-0804 WWW.romtecutilities.com	
INDIAN SPRINGS STORMWATER SANTA ROSA, CA DUPLEX LIFT STATION SYSTEM ONE LINE DIAGRAM DRAWING	
SHEET	
3	OF 4

ELECTRIC NOTES CONTINUED:

8. BACK-UP LEVEL CONTROL  
 - FLOATS  
 BACK-UP LEVEL SYSTEM WILL OPERATE THE PUMPS IN THE EVENT OF A FAILURE OF THE PRIMARY LEVEL CONTROL DEVICE.
9. PRIMARY LEVEL CONTROL  
 - AST (AST4520 PRESSUR TRANSDUCER)  
 PRIMARY LEVEL CONTROL IS USED FOR ALL OPERATIONAL POINTS WITHIN THE WET WELL.  
 - PUMP STOP POINT  
 - LEAD PUMP START POINT  
 - LAG PUMP START POINT  
 - HIGH LEVEL ALARM
10. DUPLEX PUMP CONFIGURATION  
 EBARA SUBMERSIBLE PUMPS.  
 - 300DLFU630  
 - 230V/3PH/60HZ  
 - 40HP  
 - 49.5FLA

PIPING AND VALVE NOTES:

11. VALVE VAULT  
  
 N/A
12. METER VAULT  
  
 N/A

SPECIAL NOTES:

1. THE PROJECT SITE ENGINEER AND ELECTRICAL ENGINEER ARE RESPONSIBLE FOR ALL ASPECTS OF THIS PROJECT. ROMTEC UTILITIES OFFERS THIS INFORMATION TO CLARIFY OUR PRODUCT OFFERING. THIS INFORMATION REFLECTS A TYPICAL PROJECT. DASHED LINES SHOW TYPICAL SITE WIRING/CONDUIT SUPPLIED AND INSTALLED BY ELECTRICIAN OR CONTRACTOR. PLEASE REFER TO THE PROJECT ENGINEER'S SITE PLANS AND ELECTRICAL LAYOUT FOR THE SPECIFIC DETAILS. THE PROJECT ENGINEER'S PLANS, SPECIFICATIONS AND THE APPROVED SUBMITTAL DOCUMENTS SHALL GOVERN ALL WORK.
2. ROMTEC UTILITIES DOES NOT PROVIDE CORED HOLES INTO THE WET WELL FOR ELECTRICAL CONDUIT RUNS. THE ELECTRICALLY RELATED CORED HOLES INTO THE WET WELL ARE THE RESPONSIBILITY OF THE CONTRACTOR AND ELECTRICIAN.
3. ALL COMMUNICATION DEVICES FOR REMOTE ANNUNCIATION OR SYSTEM CONTROL AND DATA ACQUISITION (SCADA) ARE TO BE CONFIGURED, TESTED, AND MAINTAINED BY OWNER/CONTRACTOR UNLESS OTHERWISE NOTED. ROMTEC UTILITIES WILL INSTALL CUSTOMER SPECIFIED COMMUNICATION DEVICES IN OUR CONTROL PANEL IF REQUESTED.

SHEET 4 OF 4	
	BY
	REVISIONS
	DATE
	REV
	1
	DESCRIPTION
	8/5/13
	OKD. KAS
	DRN. KAS
	DSN. KAS
E0106003	
© ROMTEC INC. ALL RIGHTS RESERVED. THESE PLANS AND DRAWINGS MAY NOT BE REPRODUCED, ADAPTED, OR FURTHER DISTRIBUTED, AND NO COMPONENTS MAY BE CONSTRUCTED FROM THESE PLANS, WITHOUT WRITTEN PERMISSION OF ROMTEC, INC.	
 18240 NORTH BANK ROAD ROSEBURG, OR 97470 (541)-496-9678 FAX (541)-496-0804 WWW.romtecutilities.com	
INDIAN SPRINGS STORMWATER SANTA ROSA, CA DUPLEX LIFT STATION SYSTEM ONE LINE DIAGRAM DRAWING	
SHEET 4 OF 4	

**END  
OF  
SECTION**

## **13. PUMP ELECTRICAL ENCLOSURE**

This section includes design and data pertinent to the pump electrical enclosure/panel.

This section is structured as follows:

### **13.01 PUMP ELECTRICAL ENCLOSURE DRAWINGS**



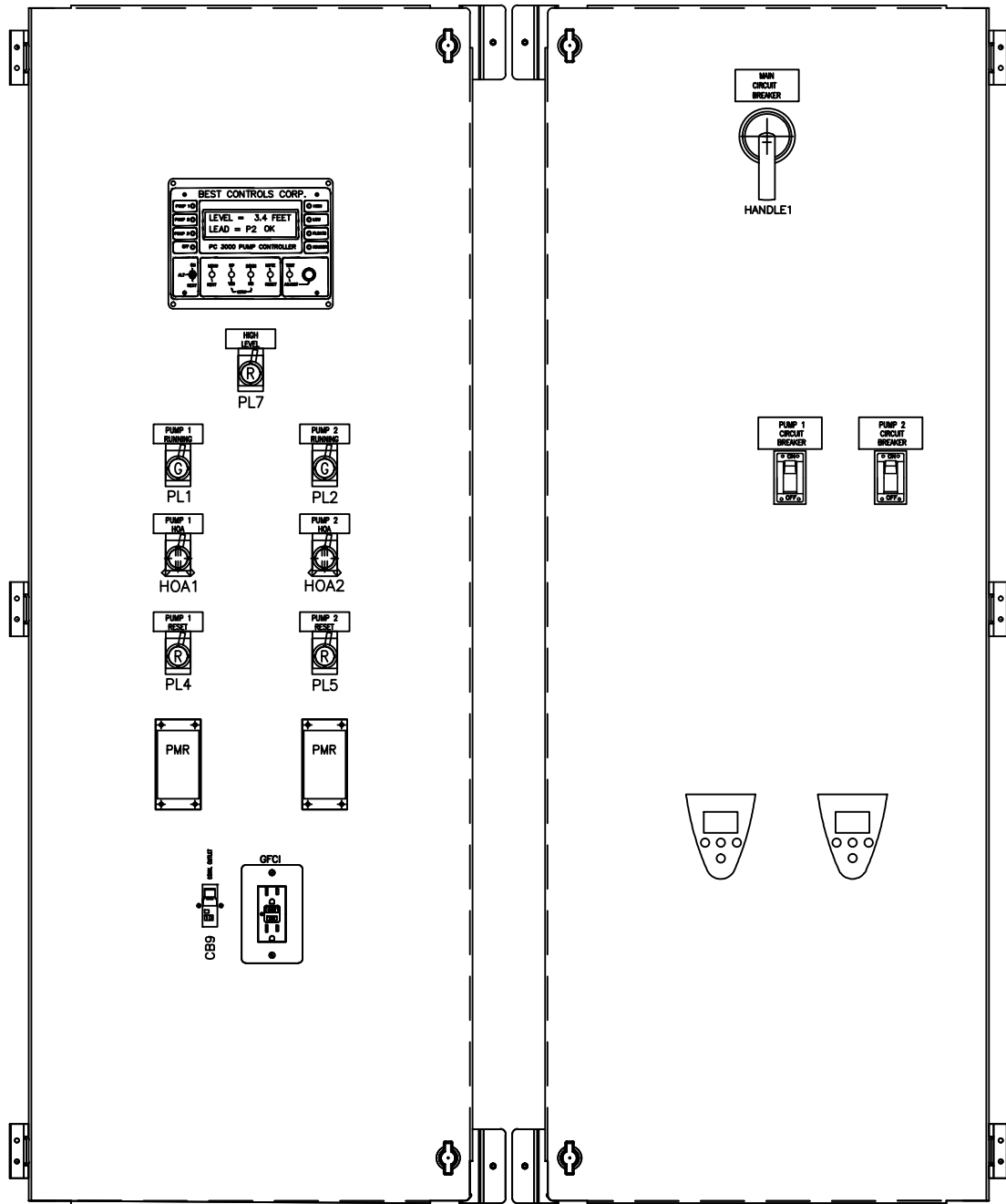

FRONT VIEW  
SWING PANELS

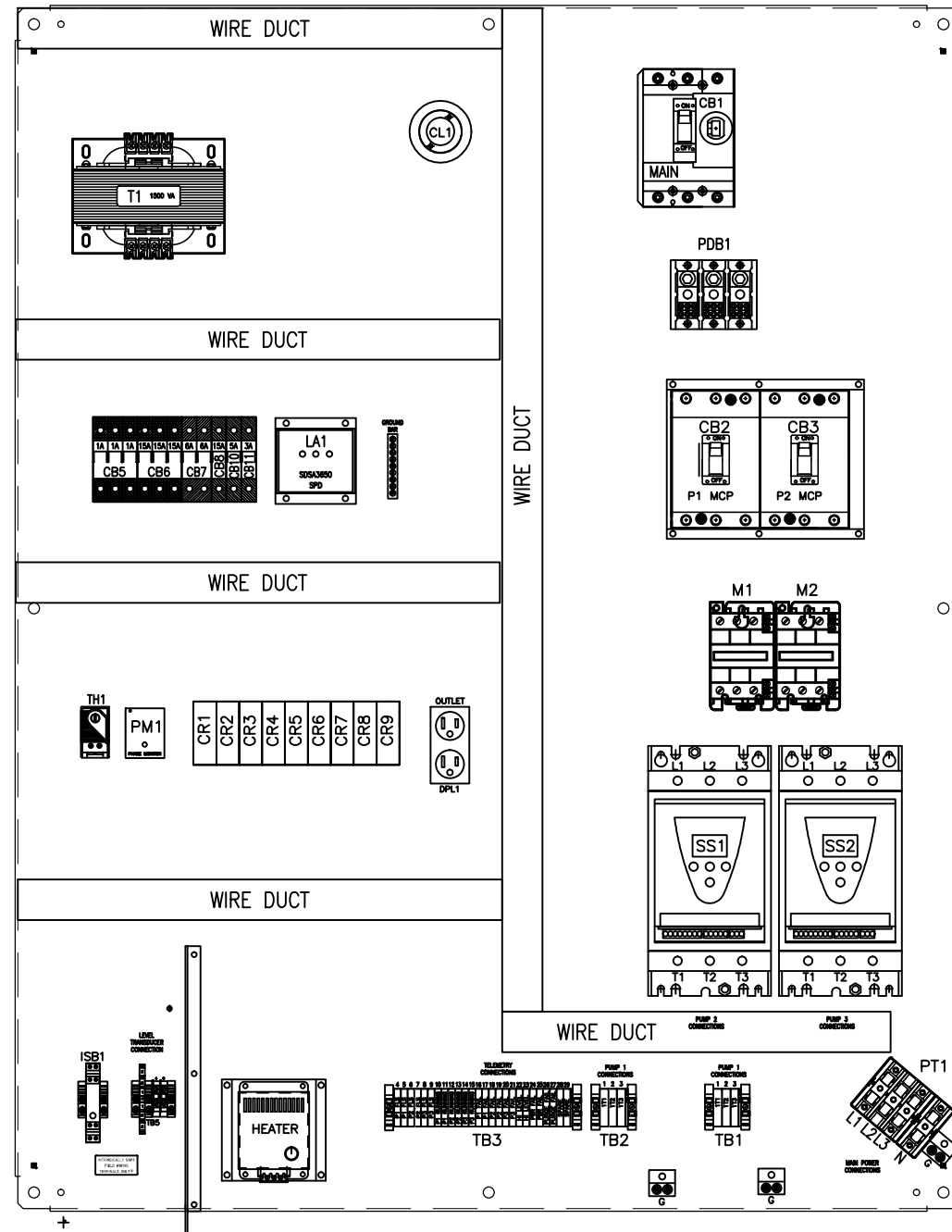

FRONT VIEW  
SUBPANEL

THE ENCLOSURE SHOWN REPRESENTS THE INTENT OF THE DESIGN. OFTEN THE ENCLOSURE SIZE AND LAYOUT MUST CHANGE TO ACCOMMODATE THE REQUIRED COMPONENTS AND FINAL DESIGN. PLEASE CONTACT ROMTEC UTILITIES TO OBTAIN ACTUAL AS-BUILT DRAWINGS BEFORE INSTALLATION.

© ROMTEC INC. ALL RIGHTS RESERVED. THESE PLANS AND DRAWINGS MAY NOT BE REPRODUCED, ADAPTED, OR FURTHER DISTRIBUTED, AND NO RESPONSIBILITY SHALL BE ASSUMED FOR THESE PLANS WITHOUT WRITTEN PERMISSION OF ROMTEC, INC.

**ROMTEC UTILITIES**  
18240 NORTH BANK ROAD  
ROSEBURG, OR 97470  
(541)-496-9678  
FAX (541)-496-0804  
WWW.romtecutilities.com

INDIAN SPRINGS LIFT STATION  
SANTA ROSA, CA  
DUPLIX LIFT STATION SYSTEM  
PANEL LAYOUT  
DRAWING

REV	DATE	DESCRIPTION	BY
1			

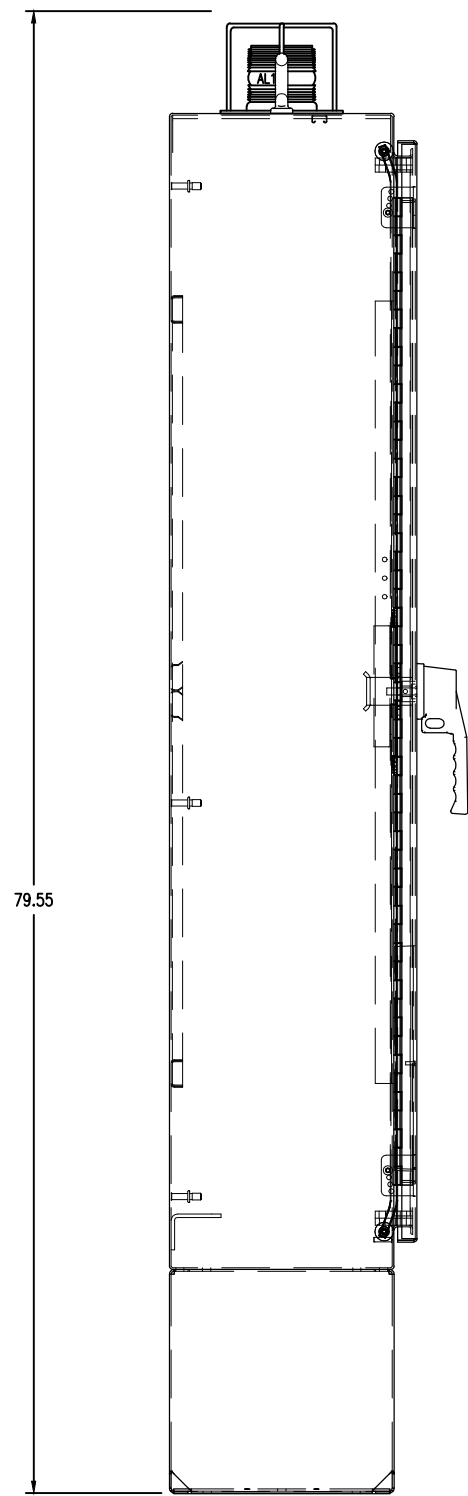

LEFT SIDE VIEW

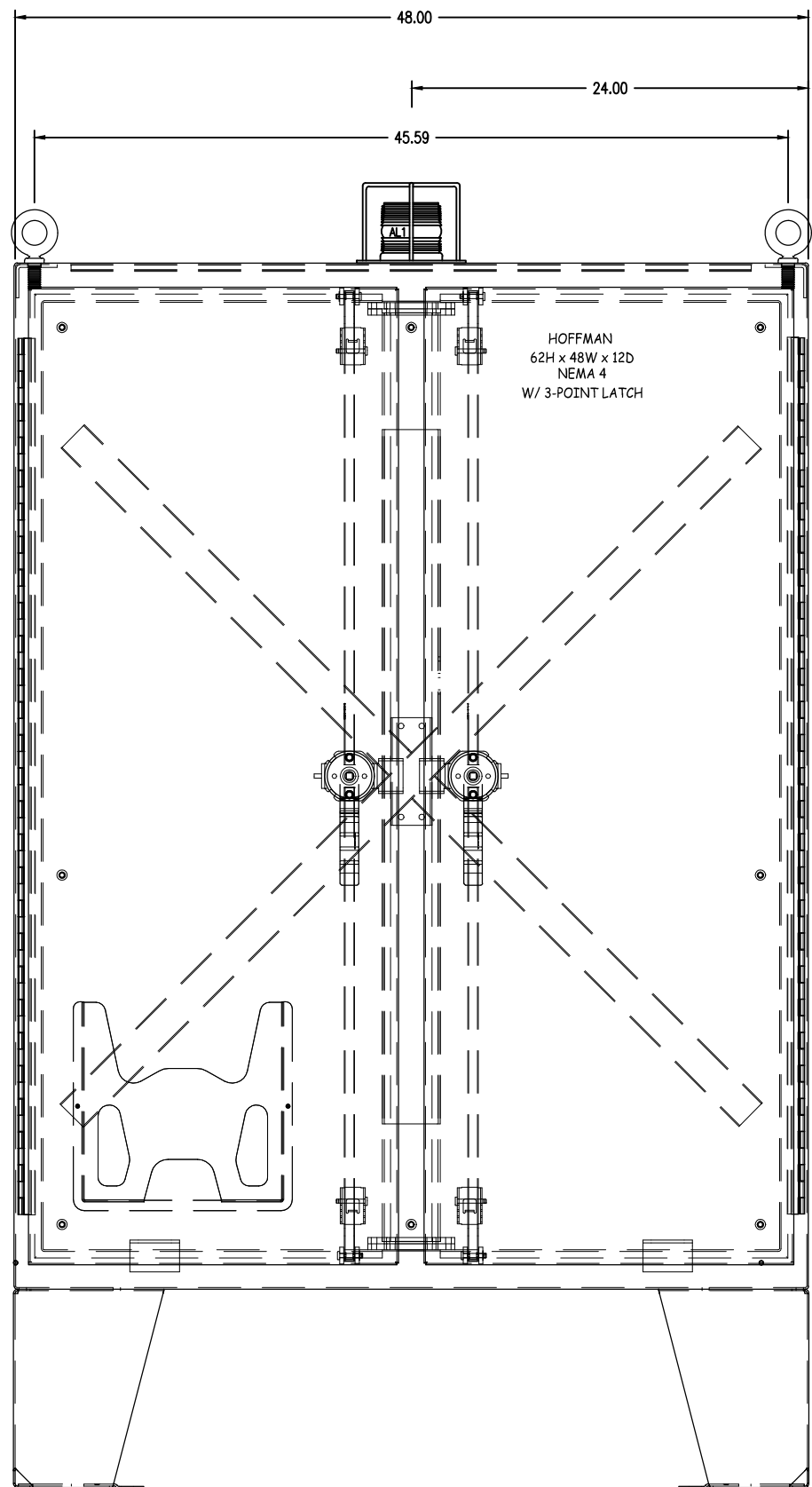

FRONT VIEW

THE ENCLOSURE SHOWN REPRESENTS THE INTENT OF THE DESIGN. OFTEN THE ENCLOSURE SIZE AND LAYOUT MUST CHANGE TO ACCOMMODATE THE REQUIRED COMPONENTS AND FINAL DESIGN. PLEASE CONTACT ROMTEC UTILITIES TO OBTAIN ACTUAL AS-BUILT DRAWINGS BEFORE INSTALLATION.

REV	DATE	DESCRIPTION	BY
1			

© ROMTEC INC. ALL RIGHTS RESERVED. THESE PLANS AND DRAWINGS MAY NOT BE REPRODUCED, ADAPTED, OR FURTHER DISTRIBUTED, AND NO COMPONENTS MAY BE CONSTRUCTED FROM THESE PLANS, WITHOUT WRITTEN PERMISSION OF ROMTEC, INC.

**ROMTEC UTILITIES**  
 18240 NORTH BANK ROAD  
 ROSEBURG, OR 97470  
 (541)-496-9678  
 FAX (541)-496-0804  
 WWW.romtecutilities.com

INDIAN SPRINGS LIFT STATION  
 SANTA ROSA, CA  
 DUPLEX LIFT STATION SYSTEM  
 PANEL LAYOUT  
 DRAWING

**END  
OF  
SECTION**

## 14. PRE-INSTALLATION

This section includes pre-installation information and an example of the checklist that Romtec Utilities requires the owner/contractor to fill out prior to installation of the system. Also included are installation data sheets that will help when installing the system.

14.01 PRE-INSTALLATION INFORMATION

14.02 PRE-INSTALLATION CHECKLIST

14.03 INSTALLATION DATA SHEETS

Send the completed Start-Up Preparation Checklist to:

Romtec Utilities Document Control  
18240 North Bank Rd., Roseburg, OR 97470  
Phone: 541-496-9678; Fax: 541-496-0804  
[Romtec8@romtecutilities.com](mailto:Romtec8@romtecutilities.com)

# Pre-Installation Information

## 1. SCHEDULING INSTALLATION

### A. LEAD TIME:

Romtec Utilities and all associated technical personnel require two (2) weeks advance notice to schedule an installation date.

### B. DURATION:

Installation begins at 8 am and will take one full day (as stated in the approved Romtec Utilities Scope of Supply and Design Submittal dated \_\_\_\_\_.

## ATTENTION

- 1. Do not lower the pumps into the wet well. A Romtec Utilities start-up advisor will do this at start-up in accordance with Romtec Utilities' warranty or warranty is voidable.**
- 2. The contractor must provide all equipment and a qualified operator to lower the pumps into the wet well on the start-up date.**

## 2. ITEMS DELIVERED FOR INSTALLATION

### PLEASE REVIEW

#### A. **Pre-cast Base Slab**

- Ready to set
  - NOTE: *The specification and the process for creating a stable compacted "footing" or "base" for the Romtec Utilities wet well foundation is by others. Creating a compacted base that will not allow the Romtec Utilities wet well to "settle" and/or "tilt" during or after installation is not the responsibility of Romtec Utilities*
- Pump discharge elbows attached
- Lifting methodology included:

1. **WARNING! WEIGHTS OF CONCRETE VARY!** See approved scope of supply and design submittal section\_\_\_\_\_, dated \_\_\_\_\_ for concrete weights.
2. The contractor must provide a crane capable of lifting the base.
3. **LIFTING STRAP RECOMMENDATIONS**
  - a. 4' Base, barrels and vault: Four (4) 16' straps.
  - b. 5' Base, barrels and vault: Four (4) 16' straps.
  - c. 6' Base, barrels and vault: Four (4) 16' straps.
  - d. 8' Base, barrels and vault: Four (4) 16' straps.
  - e. 10' Base, barrels and vault: Four (4) 16' straps.
4. **PAY ATTENTION!** Check the alignment marks on all concrete pieces. Check that all pieces are numbered, in order, bottom to top.
5. **IMPORTANT IF YOU ARE USING SHORING!** The base and first barrel are one solid piece. The base slab is square, rectangular or round! The shoring must be wide enough to allow rotation of the base 360 degrees to be able to align the gravity sewer and force main. See approved scope of supply and design submittal section\_\_\_\_\_, dated\_\_\_\_\_ for concrete dimensions.

#### B. Pre-cast Barrels

- i. All discharge and inlet holes pre-cored plus Kor-n-Seals installed.
- ii. Romtec Utilities does not provide cored holes into the wet well for electrical conduit ports or conduit runs unless specified in the Scope of Supply and Design Submittal. The electrical related cored holes in the wet well are the responsibility of the contractor and electrician. Wet well electrical related cored holes final size, orientation, height and number are best determined after installation of the wet well and other electrical components.
- iii. If the wet well includes Ameron T-Lock lining, all joints, cored holes and all penetrated concrete must be welded by a "Certified" Ameron welder. All piping going through the wet well must be installed prior to the welding.

- C. **Pre-cast/Pre-Fabricated Top Slab**
- i. This is the last concrete piece.
- D. **Accessory Pallet**
- i. Wet well gaskets and sealers
  - ii. Discharge pipe (pre-fabricated)
    1. **WARNING! TRIM TO FIT.**
    2. Discharge pipe intentionally too long, the contractor must measure and trim to fit.
    3. Contractor must plumb discharge pipe and secure to wet well using the pre-installed bracket.
  - iii. Level sensing devices (store for installation at start-up)
  - iv. **In the accessory pallet there are going to be items that you will NEED to complete Start up of your pump station. Please keep track of these items for start up. Your pump station will not be able to be completed without them.**
- E. **Guiderails**
- i. **WARNING!** Trim to fit. Guiderails are produced too long intentionally; the contractor must measure and trim to fit.
- F. **Upper Guiderail Brackets**
- i. **PLEASE!** Install in provided nut rail already built into top slab hatch.
  - ii. Mounting hardware included.
  - iii. Contractor must plumb guide rails before tightening the supplied bolts.
- G. **Inside drop system (Optional)**
- i. **LOOK!** Inside drop system goes in wet well on pre-installed concrete anchors and provided pipe brackets.
  - ii. Look for, and install PVC drop pipe between inside drop bowl (pre-installed) and wet well base.
  - iii. EXPLANATION: The inside drop system is intended to direct the influent water and guide the flow.

- H. **Pump Disconnect Panel and Stand (optional)**
  - i. Electrician to install the conduits between the disconnect panel and the control panel per the site engineer's direction. This includes one to three power conduits and one separate conduit for level sensing.
  
- I. **Electrical Junction Box (optional)**
  - i. **WARNING!** Electrician to install.
  - ii. Electrician to install the conduits between the electrical junction box and the control panel per the site engineer's direction. This includes one to three power conduits and one separate conduit for level sensing.
  
- J. **Control Panel (if included in this shipment)**
  - i. **WARNING!** Electrician to install per site engineer's direction.
  
- K. **Pumps (if included in this shipment)**
  - i. Installed by Romtec Utilities after system construction.
  - ii. You do not need to bring pumps to the site until start-up.
  - iii. **PLEASE!** Leave the pumps and chains at the contractor's office until start-up.

**3. THE FOLLOWING ARE STRONGLY RECOMMENDED ON SITE:**

- A. Two (2) six-foot ladders.
- B. One (1) six-foot level.
- C. Shoring for safe working space in the hole and shoring of adequate size for room around the base slab.
- D. Crane to off load and set all concrete components.
- E. Forklift to offload accessory pallet and control panel (may be shipped separately at a later date).
- F. Secure site for accessory pallet (and control panel with pumps, when they arrive). These items may need to be hauled to a secure site. Please provide a truck to transfer these items to a separate site if necessary.
- G. Review the site and **LOOK** for overhead obstructions before delivery.
- H. A person on-site whose sole purpose is to be in charge of safety.





## Pre-Installation Checklist

Please fill out this form accurately. If the equipment and excavated site is not ready for installation of the wet well and associated parts, the installer will be responsible for all costs associated with the initial site visit.

*Note: The Romtec Utilities Installation Advisor is on-site as an advisor only. The Romtec Utilities Advisor will not be performing any of the installation tasks.*

Please have this form completed and returned a minimum of two weeks prior to the arrival of the Install Advisor to ensure time for this document to be reviewed. Send this completed Pre-Installation Checklist to:

Romtec Utilities Post Sales Coordinator  
18240 North Bank Rd.  
Roseburg, OR 97470  
Phone: 541-496-9678; Fax: 541-496-0804  
[romtec8@romtecutilities.com](mailto:romtec8@romtecutilities.com)

### Jobsite information:

Street Address: \_\_\_\_\_  
State: \_\_\_\_\_ Zip Code: \_\_\_\_\_

### Name of Main Site Contact:

Name: \_\_\_\_\_  
Company: \_\_\_\_\_  
Phone: \_\_\_\_\_  
E-mail: \_\_\_\_\_

### Safety Coordinator on Site:

Name: \_\_\_\_\_  
Company: \_\_\_\_\_  
Phone: \_\_\_\_\_  
E-mail: \_\_\_\_\_

**Requested Delivery Date of Wet well assembly:** \_\_\_\_\_

*Note: All equipment necessary to off load the wet well and associated parts must be on site and ready for the truck on the above requested delivery date .*

**PLEASE COMPLETE THE FOLLOWING TO CONFIRM YOU ARE READY FOR  
 INSTALLATION**

- |   | <b>YES</b>               | <b>NO</b>                |
|---|--------------------------|--------------------------|
| 1. Will the site be prepared by the delivery date established?  | <input type="checkbox"/> | <input type="checkbox"/> |
| 2. Is the contractor ready to begin construction?   | <input type="checkbox"/> | <input type="checkbox"/> |
| 3. Is the hole excavated and prepared per site engineer specifications?<br><br>If not, when will it be ready?_____  | <input type="checkbox"/> | <input type="checkbox"/> |
| 4. Will the crane be on-site on the delivery day to unload the Romtec Utilities supplied items from the delivery trucks?  | <input type="checkbox"/> | <input type="checkbox"/> |
| 5. Has the contractor confirmed that the crane has appropriately stable ground from which to work?  | <input type="checkbox"/> | <input type="checkbox"/> |
| 6. Will the contractor be ready to stack the wet well and possibly install the valve vault & related piping on the delivery date?   | <input type="checkbox"/> | <input type="checkbox"/> |
| 7. Will the hole be shored? Is the shoring wide enough to be able to rotate the base 360 degrees?<br>Base dimensions:_____  | <input type="checkbox"/> | <input type="checkbox"/> |
| 8. Will the contractor have adequate dewatering on-site?  | <input type="checkbox"/> | <input type="checkbox"/> |
| 9. Will the bottom of the hole have the base rock installed and compacted and level as per site engineer's requirements, prior to 8:00 AM on the above requested installation date? | <input type="checkbox"/> | <input type="checkbox"/> |

*Note: Construction should not occur on the same day the hole is being excavated.*

- |   | <b>YES</b>               | <b>NO</b>                |
|---|--------------------------|--------------------------|
| <p><b>10.</b> Will someone from the contractor's company review and verify the Romtec Utilities packing list and the supply of all equipment?</p> <p><i>Note: If there is not a Romtec Utilities Installation Advisor on site, please scan and e-mail or fax to Romtec Utilities after this has been completed.</i></p> | <input type="checkbox"/> | <input type="checkbox"/> |
| <p><b>11.</b> Who will review and verify? _____</p>   |                          |                          |
| <p><b>12.</b> Will the contractor provide at least one laborer exclusively for unloading the truck and prepping concrete parts per Romtec Utilities direction?</p>  | <input type="checkbox"/> | <input type="checkbox"/> |
| <p><b>13.</b> Does the contractor recognize that the elevations in section 16 are the elevations in the Romtec Utilities system drawing, and these are the governing elevations?</p> <p><i>Note: Please list the elevations you have in the table below, and mark any elevations that do not match.</i></p>             | <input type="checkbox"/> | <input type="checkbox"/> |
| <p><b>14.</b> Has a safety plan for installation been developed and implemented in conformance with OSHA requirements?</p>  | <input type="checkbox"/> | <input type="checkbox"/> |
| <p><b>15.</b> Does the safety plan include components for confined spaces, climbing, high voltage (underground and overhead) and shoring?</p>   | <input type="checkbox"/> | <input type="checkbox"/> |
| <p><b>16.</b> Have contractor's employees been instructed with respect to the safety plan?</p>  | <input type="checkbox"/> | <input type="checkbox"/> |



17. Does the contractor agree that these are the correct elevations?

*Note: These elevations are based on our approved Scope of Supply and Design Submittal. Please call our office immediately if your elevations do not match ours.*

	RU ELEVATION	YOUR ELEVATION	DO THEY MATCH
WET WELL RIM	352.40'		<input type="checkbox"/> YES <input type="checkbox"/> NO
WET WELL FLOOR	340.40'		<input type="checkbox"/> YES <input type="checkbox"/> NO
WET WELL BASE	339.40'		<input type="checkbox"/> YES <input type="checkbox"/> NO
WET WELL DISCHARGE INVERT	347.40'		<input type="checkbox"/> YES <input type="checkbox"/> NO
WET WELL INFLUENT INVERT	345.12'		<input type="checkbox"/> YES <input type="checkbox"/> NO

**COMMENTS:**

---

---

---

---

---

---

---

---

---

---

---

---

\_\_\_\_\_  
 AUTHORIZED SIGNATURE

\_\_\_\_\_  
 PRINT NAME

\_\_\_\_\_  
 DATE

## SAFETY DISCLOSURE & ACKNOWLEDGMENT

### Installation Safety Threats

Installation of the equipment to be supplied may implicate five (5) specific potential safety threats, among others:

1. Work in confined spaces, particularly within the wet wells, valve vaults and meter vault.
2. Inadequate shoring of dirt walls in the installation well.
3. Work at heights, relative to the base of the lift station in the bottom of the excavated hole.
4. Misuse of machinery, such as cranes, used in installation.
5. High voltage.

### Acknowledgment of Responsibility

Your signature below signifies your acceptance of the following:

1. You (including, but not limited to, you, your employees, or your Contractor), and not Romtec Utilities, assume full responsibility for installation of the equipment.
2. You are not an agent of Romtec Utilities in any capacity.
3. Romtec Utilities will provide fundamental instruction regarding installation by a Romtec Utilities advisor, but any such advisor will have no authority or obligation to supervise or direct your personnel in the course of installation.
4. **You are solely responsible for ensuring safety in all facets of installation.**

By signing this form you are agreeing to each of the above. Please contact our office with any questions or concerns you may have.

---

SIGNATURE

---

DATE

PAGE IS INTENTIONALLY LEFT BLANK

ROMTEC  
WET WELL ASSEMBLY

COMPACTED BACK FILL  
AS SPECIFIED BY THE  
ENGINEER

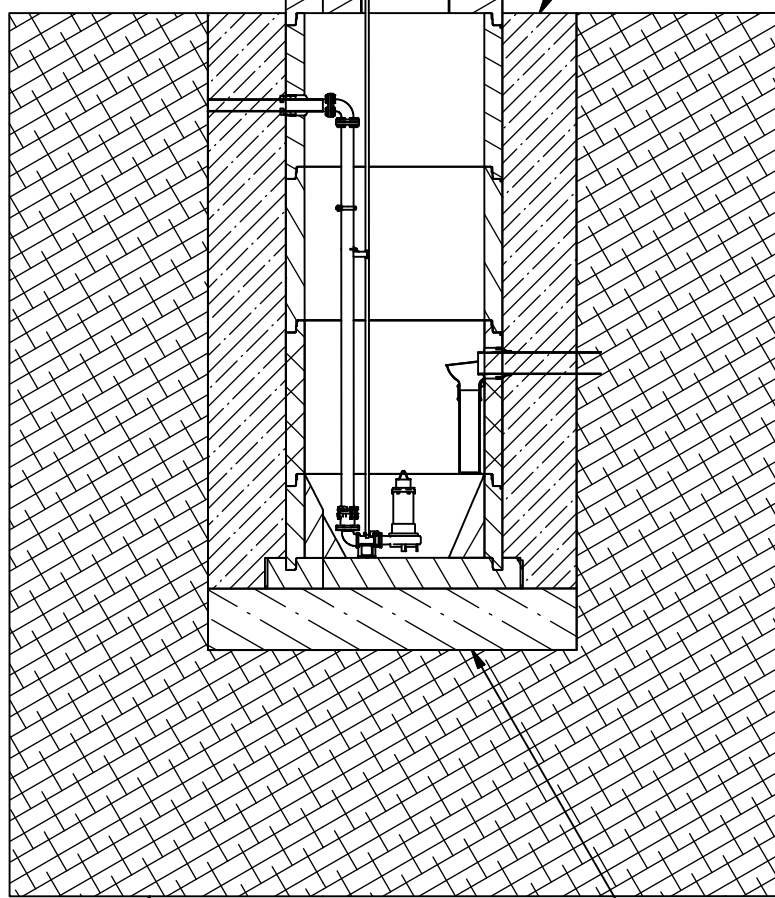

UNDISTURBED SOIL

COMPACTED BASE ROCK  
AS REQUIRED & SPECIFIED  
BY THE ENGINEER

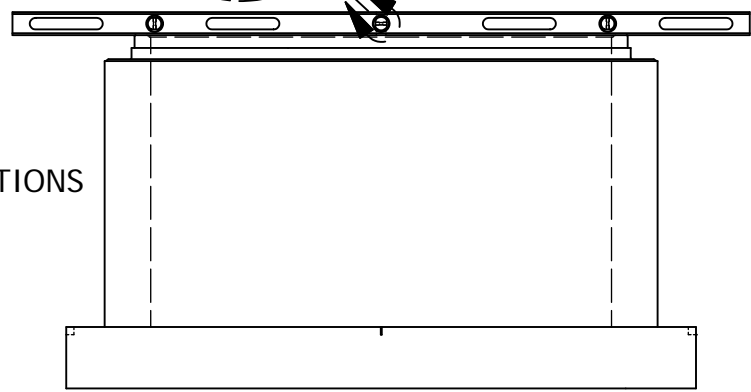
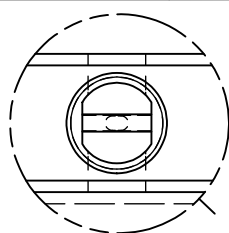

NOTE: BASE MUST BE  
LEVELED IN ALL DIRECTIONS  
PRIOR TO STACKING  
BARRELS.

DRN BY	AM	DATE	04/10/13		18240 NORTH BANK ROAD ROSEBURG, OREGON 97470 541-496-3541	
CHK BY		DATE				
APR BY		DATE		DESCRIPTION		
				WET WELL BASE LEVELING		
				DWG NO		REV

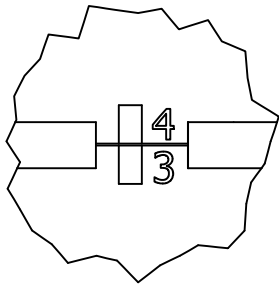

ALIGNMENT MARKS AND NUMBERS FOR MATCHING THE BARRELS

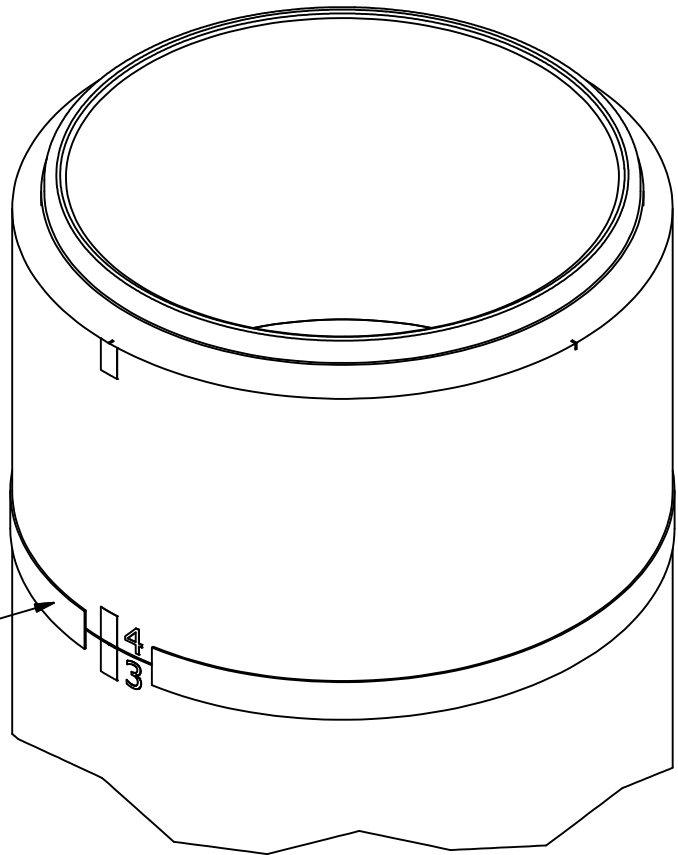

TAPE COAT INSTALLED AT EACH BARREL JOINT SUPPLIED BY ROMTEC UTILITIES INSTALLED BY CONTRACTOR

BARREL

TAPECOAT

TYLOX SUPER SEAL GASKET (MAKE SURE GASKET IS AGAINST SHOULDER)

1" X 1" CONSEAL FOR 6', 8' & 10'  
3/4" X 3/4" CONSEAL FOR 4' & 5'

TAPECOAT

BARREL

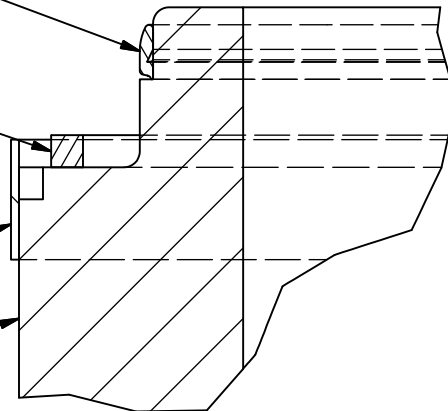
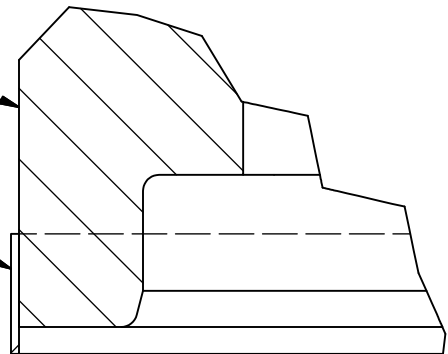

DRN BY	AM	DATE	09/23/08		18240 NORTH BANK ROAD	
CHK BY		DATE			ROSEBURG, OREGON 97470	
APR BY		DATE		DESCRIPTION	541-496-3541	
				BARREL JOINT SEALS		
				DWG NO		REV



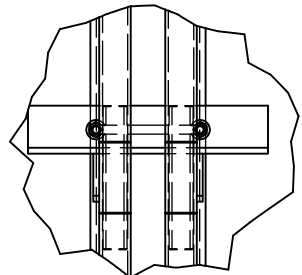
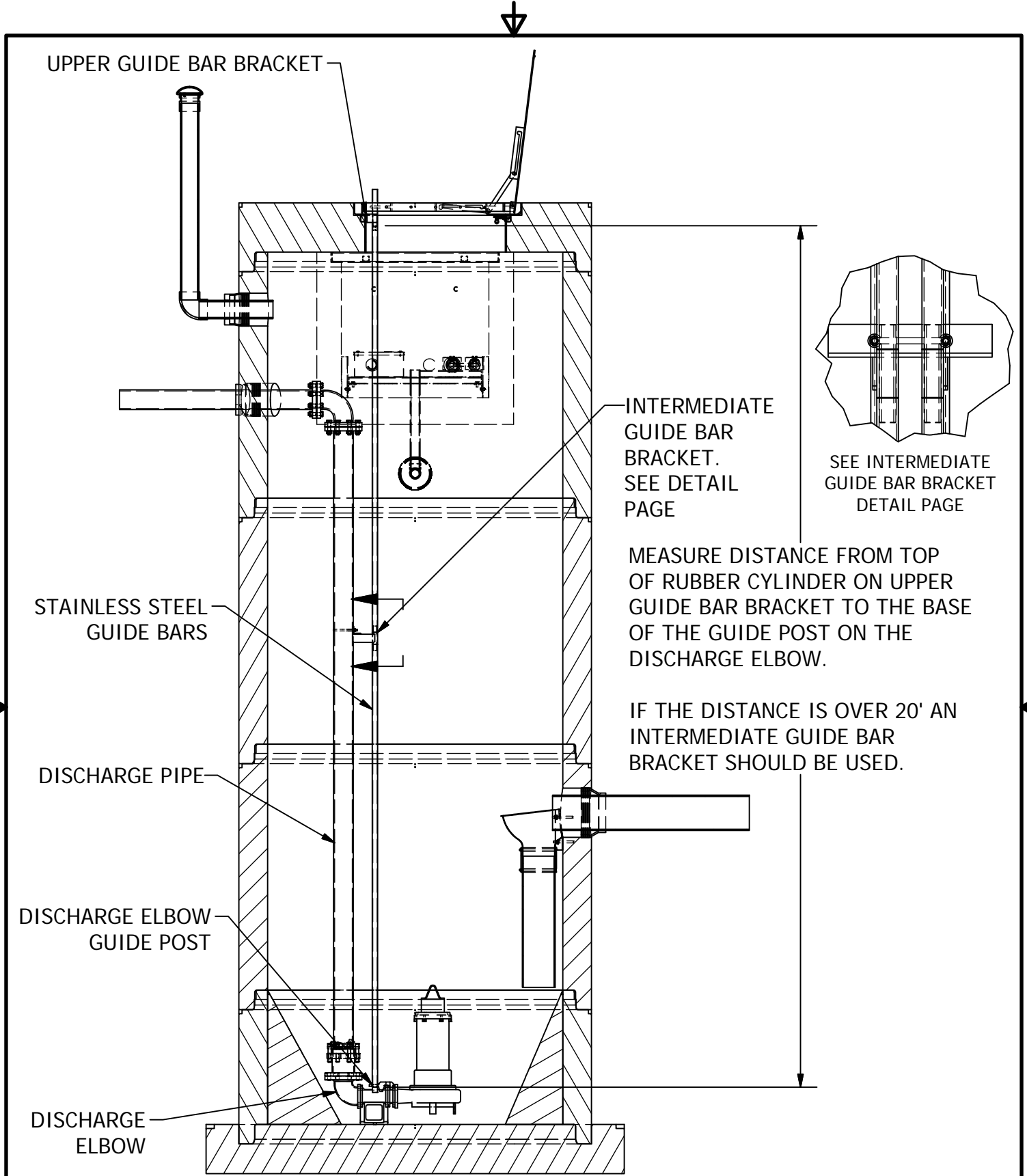

SEE INTERMEDIATE  
GUIDE BAR BRACKET  
DETAIL PAGE

INTERMEDIATE  
GUIDE BAR  
BRACKET.  
SEE DETAIL  
PAGE

MEASURE DISTANCE FROM TOP  
OF RUBBER CYLINDER ON UPPER  
GUIDE BAR BRACKET TO THE BASE  
OF THE GUIDE POST ON THE  
DISCHARGE ELBOW.

IF THE DISTANCE IS OVER 20'  
AN INTERMEDIATE GUIDE BAR  
BRACKET SHOULD BE USED.

DRN BY	AM	DATE	04/11/13		18240 NORTH BANK ROAD ROSEBURG, OREGON 97470 541-496-3541	
CHK BY		DATE				
APR BY		DATE				
				DESCRIPTION		
				GUIDE BAR MEASUREMENT		
				DWG NO		REV

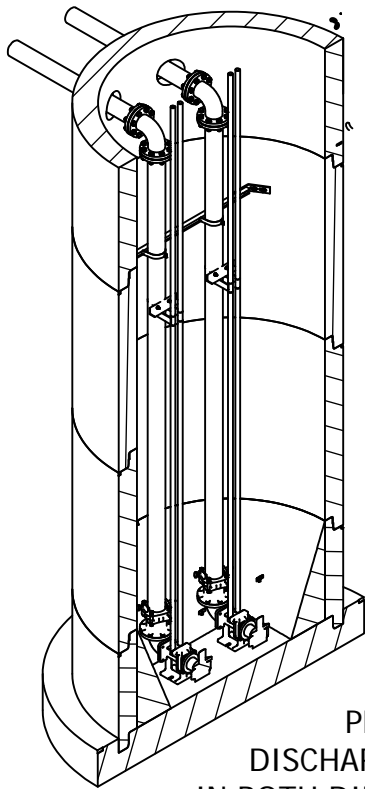

MEASURE FROM  
THE INSIDE SHOULDER  
OF THE DISCHARGE  
ELBOW TO THE BOTTOM  
OF THE INSIDE DIAMETER  
OF THE KOR-N-SEAL

PLUMB THE  
DISCHARGE PIPES  
IN BOTH DIRECTIONS  
BEFORE TIGHTENING  
DISCHARGE ELBOW

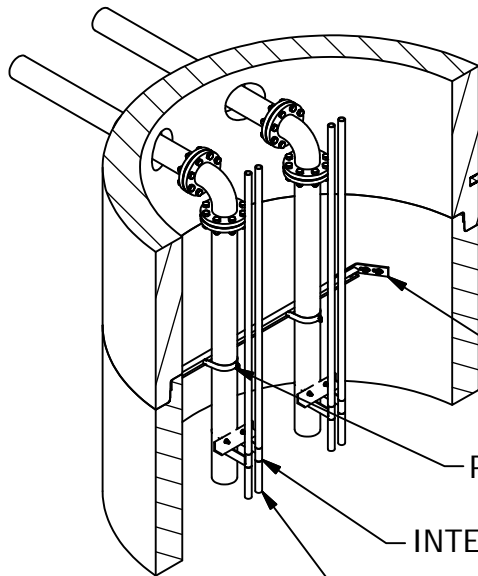

DISCHARGE PIPE SUPPORT ASSEMBLY

PIPE CLAMPS

INTERMEDIATE GUIDE BAR BRACKETS (IF REQD)

STAINLESS STEEL GUIDE BARS

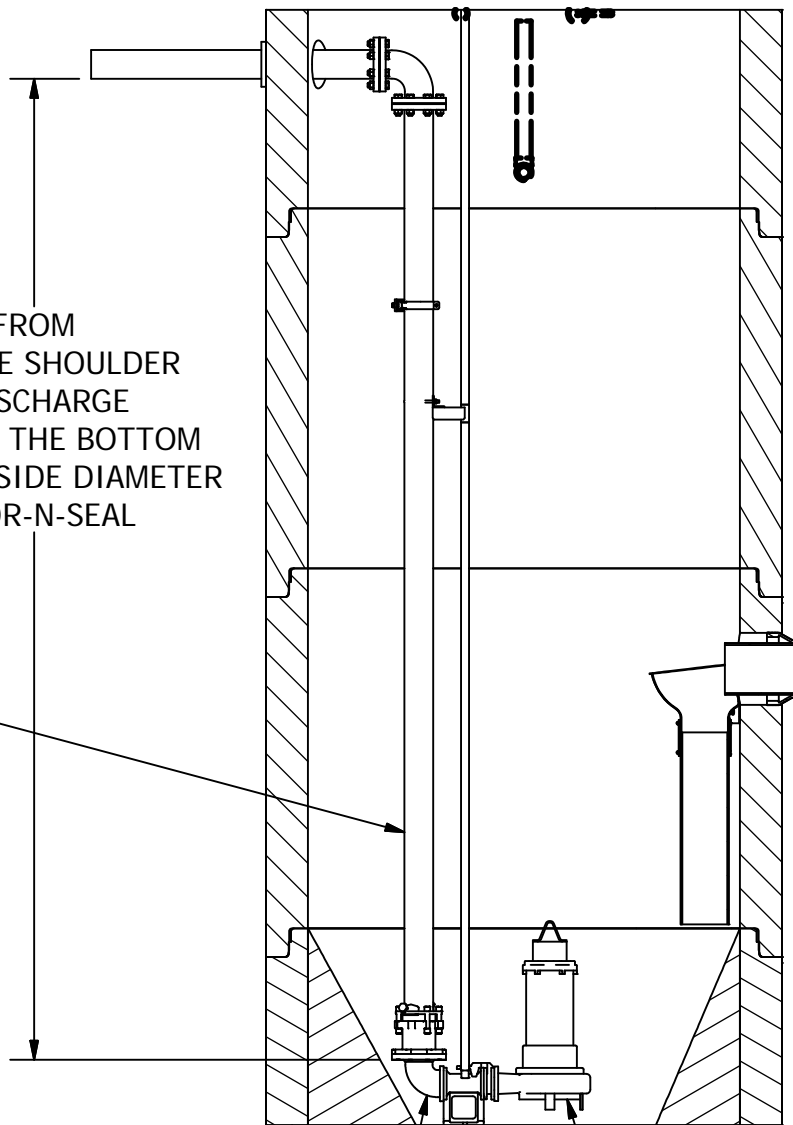

DISCHARGE ELBOW

PUMPS

DRN BY	AM	DATE	04/11/13
CHK BY		DATE	
APR BY		DATE	



18240 NORTH BANK ROAD  
ROSEBURG, OREGON 97470  
541-496-3541

DESCRIPTION

DISCHARGE PIPE ASSEMBLY

DWG NO

REV

NOTE: ADJUST DISCHARGE PIPE BRACKET TO PLUMB DISCHARGE PIPE. PLUMB DISCHARGE PIPE IN BOTH DIRECTIONS BEFORE TIGHTENING ALL BOLTS.

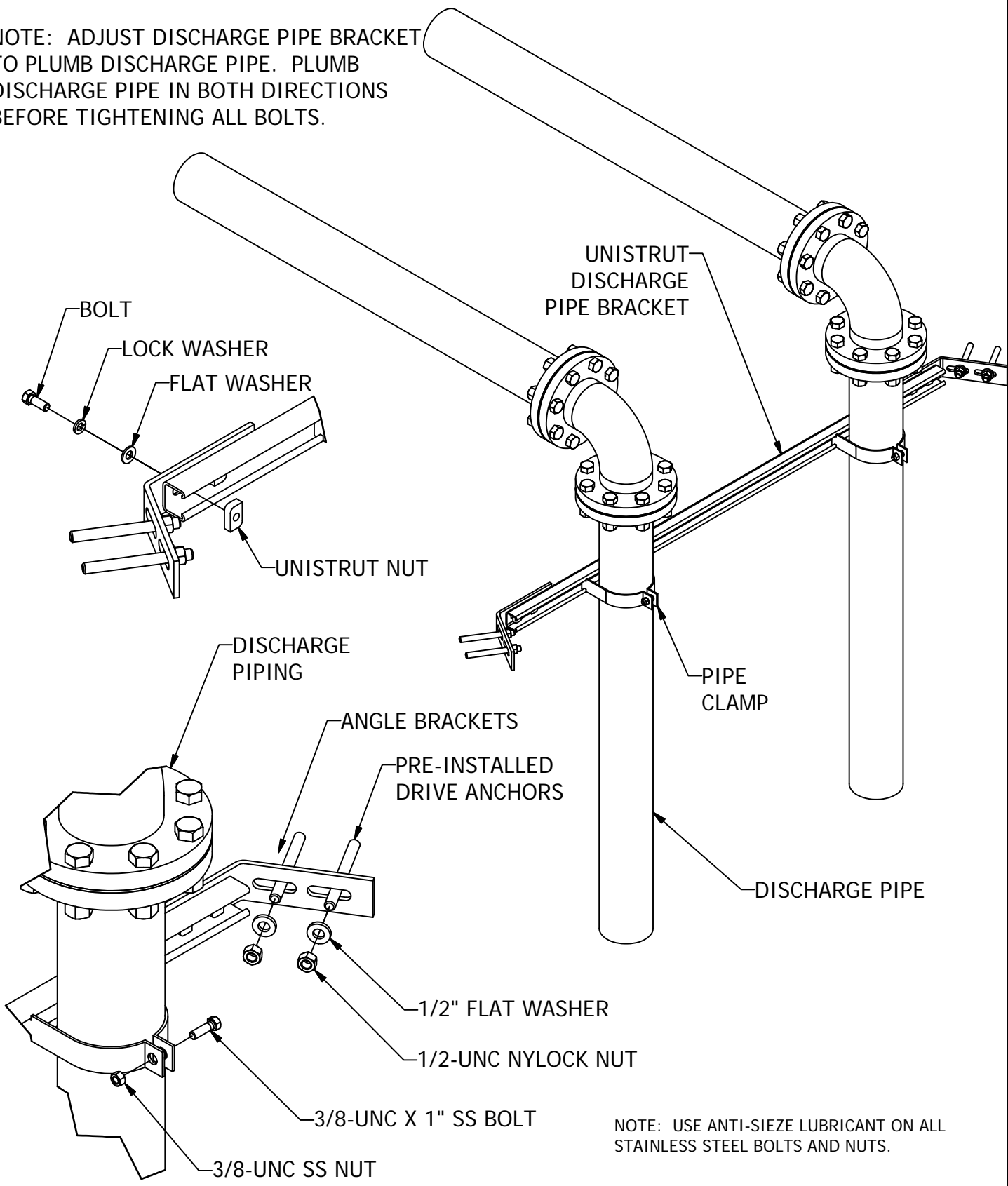

DRN BY	AM	DATE	09/11/08		18240 NORTH BANK ROAD ROSEBURG, OREGON 97470 541-496-3541
CHK BY		DATE			
APR BY		DATE		DESCRIPTION	
				DISCHARGE PIPE BRACKETS	
				DWG NO	REV

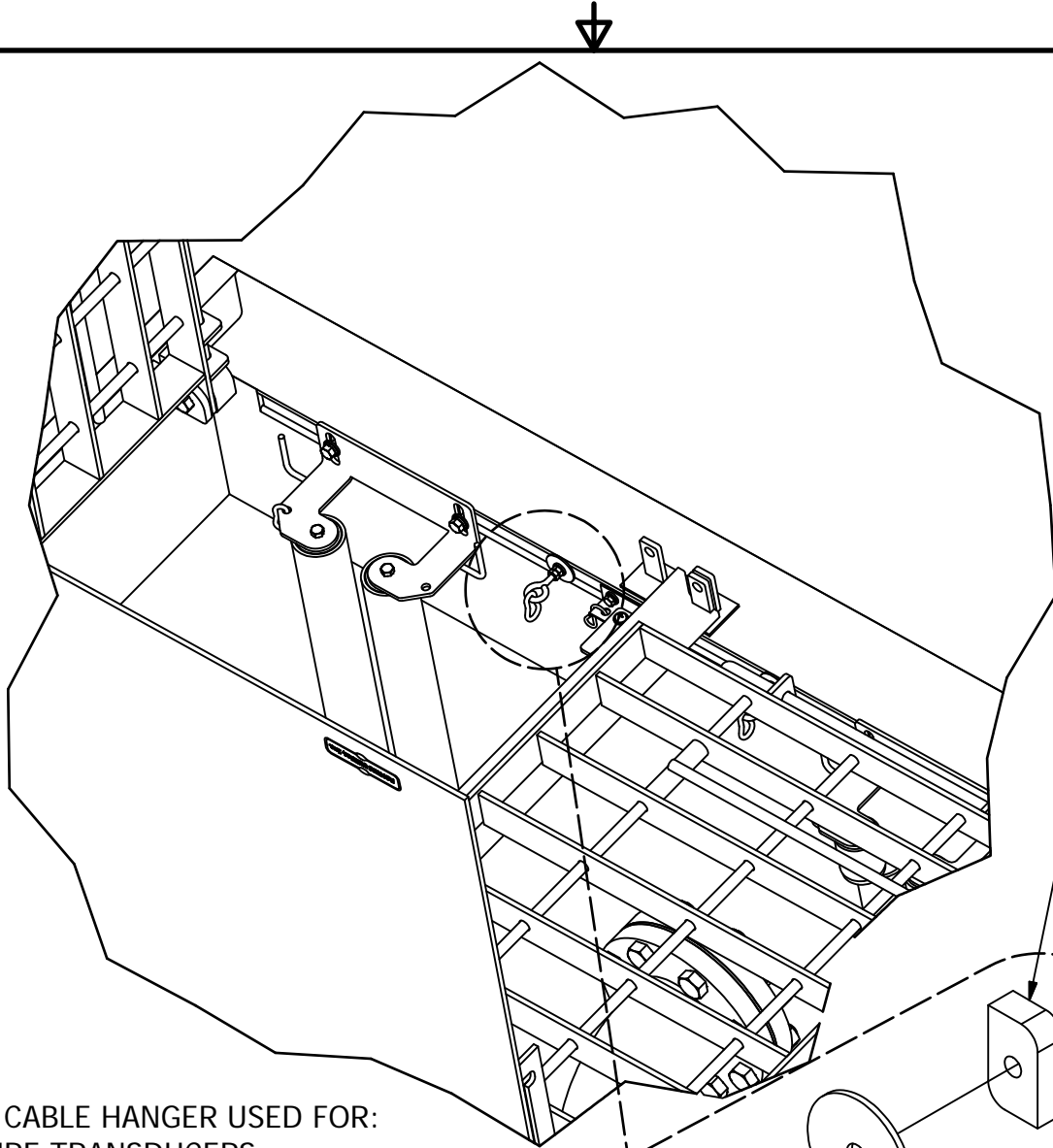

NOTE: CABLE HANGER USED FOR:  
 PRESSURE TRANSDUCERS  
 ULTRA SONIC SENSORS  
 MECHANICAL FLOAT SWITCHES

SPRING CLIP

UNISTRUT  
 NUT

1/4" X 1 1/2"  
 SS FENDER WASHER

1/4" SS FLAT WASHER

1/4-UNC SS HEX NUT

1/4" SS EYE BOLT

NOTE: USE ANTI-SIEZE LUBRICANT ON ALL  
 STAINLESS STEEL BOLTS AND NUTS.

DRN BY	AM	DATE	09/12/08		18240 NORTH BANK ROAD ROSEBURG, OREGON 97470 541-496-3541	
CHK BY		DATE				
APR BY		DATE		DESCRIPTION		
				CABLE HANGER ASSEMBLY		
				DWG NO		REV

WET WELL TOP SLAB

4" SCH80 PVC PIPE

WET WELL BARREL

KOR-N-SEAL BOOT  
(Ø8" CORED HOLE)

DRN BY	AM	DATE	09/22/08		18240 NORTH BANK ROAD ROSEBURG, OREGON 97470 541-496-3541
CHK BY		DATE			
APR BY		DATE		DESCRIPTION	
				SIDE MOUNT PVC VENT	
				DWG NO	REV

**END  
OF  
SECTION**

## **15. FIELD START-UP REPORT**

This section includes the Field Start-UP Report to be filled out by Romtec Utilities onsite advisor at the scheduled start-up of the system.

This section is structured as follows:

15.01 FIELD START-UP REPORT

# FIELD START-UP REPORT

TO BE COMPLETED BY ROMTEC UTILITIES START-UP TECHNICIAN

DATE: \_\_\_\_/\_\_\_\_/\_\_\_\_

## (SITE OVERVIEW)

### 1. STRUCTURAL / MECHANICAL CONSTRUCTION

A. Are all the components for the wet well and valve vault installed and approved?

Yes       No

### 2. OPERATION & MAINTENANCE MANUAL

A. Please fill in the contact information for the person that the O&M Manual should be mailed to.

Contact: \_\_\_\_\_

Address: \_\_\_\_\_

Phone: \_\_\_\_\_

Email: \_\_\_\_\_

### 3. ELECTRICAL CONSTRUCTION

A. Have the conduits been installed between the wet well and the main control panel minimum (one (1) for each pump, one (1) for level control)?

Yes       No      Installed by \_\_\_\_\_

B. Have the "pump power" wires been pulled between the main control panel and the wet well?

Yes       No      Installed by \_\_\_\_\_

C. Have the level control signal wires been pulled between the pump control panel and the wet well?

Yes       No      Installed by \_\_\_\_\_

D. Have the level control wires been landed on the appropriate terminals inside the control panel?

Yes       No      Installed by \_\_\_\_\_



- E. Have the panel power wires been installed between the main disconnect, automatic transfer switch (if present) and the pump control panel?  
 Yes       No
- F. Have the "meter base" and main disconnect been installed and inspected?  
 Yes       No
- G. Has the power company energized the meter?  
 Yes       No

**4. COMMUNICATION EQUIPMENT**

- A. Has all required communication equipment (radio, phone, cellular) been installed and tested and operational?  
 Yes       No       NA

**5. WATER AVAILABILITY**

- A. Is there enough water available for a minimum of ½ hour of pumping?  
 Yes       No

**(TESTING AND START-UP)**

**1. PUMP DATA**

Pump: P-1 Model: \_\_\_\_\_ Serial No.: \_\_\_\_\_ Imp.: \_\_\_\_\_ HP: \_\_\_\_\_ FLA: \_\_\_\_\_  
Pump: P-2 Model: \_\_\_\_\_ Serial No.: \_\_\_\_\_ Imp.: \_\_\_\_\_ HP: \_\_\_\_\_ FLA: \_\_\_\_\_  
Pump: P-3 Model: \_\_\_\_\_ Serial No.: \_\_\_\_\_ Imp.: \_\_\_\_\_ HP: \_\_\_\_\_ FLA: \_\_\_\_\_

- A. Do the above meet the approved scope of supply?  
 Yes       No (Explain in Comments)

**2. PUMP CONTROL DATA**

Primary Level Control Type/Mfg./Model: \_\_\_\_\_  
Secondary Level Control Type/Mfg./Model: \_\_\_\_\_

- A. Do the above meet the approved scope of supply?

**Yes**       **No (Explain in Comments)**

**3. PHYSICAL INSPECTION**

A. Have all of the terminals and lugs been checked for tightness?

**Yes**       **No**       **NA**

B. Inspected pumps and cable for damage?

**P-1:**  **Yes**       **No**       **NA**

**P-2:**  **Yes**       **No**       **NA**

**P-3:**  **Yes**       **No**       **NA**

C. Check oil in seal chamber for condition and quantity?

**P-1:**  **Yes**       **No**       **NA**

**P-2:**  **Yes**       **No**       **NA**

**P-3:**  **Yes**       **No**       **NA**

D. Does impeller spin freely when rotated by hand?

**P-1:**  **Yes**       **No**       **NA Verified by** \_\_\_\_\_

**P-2:**  **Yes**       **No**       **NA**

**P-3:**  **Yes**       **No**       **NA**

E. Discharge connection level and tight (verify with contractor)?

**P-1:**  **Yes**       **No**       **NA**

**P-2:**  **Yes**       **No**       **NA**

**P-3:**  **Yes**       **No**       **NA**

F. Guide bars vertical and tight (verify with contractor)?

**P-1:**  **Yes**       **No**       **NA**

**P-2:**  **Yes**       **No**       **NA**

**P-3:**  **Yes**       **No**       **NA**

G. Lifting cable free of damage and connected securely?

**P-1:**  **Yes**       **No**       **NA**

**P-2:**  **Yes**       **No**       **NA**

**P-3:**  **Yes**       **No**       **NA**

H. Electrical connections tight and connected correctly?

**P-1:**  **Yes**       **No**       **NA**

P-2:  Yes       No       NA  
 P-3:  Yes       No       NA

- I. Pump station free of debris?  
 Yes       No       NA (Explain in Comments)
- J. Junction boxes, conduits, seals installed correctly?  
 Yes       No       NA
- K. Is the system properly grounded and bonded?  
 Yes       No       NA
- L. Are cord grips properly installed?  
 Yes       No       NA
- M. Are the working clearance requirements maintained as per code?  
 Yes       No       NA
- N. Are all level sensing devices installed as designed & properly documented?  
 Yes       No       NA
- O. Are the schematics on the door accurate?  
 Yes       No       NA

**4. PRE-START-UP PUMP ELECTRICAL CHECKS**

Resistance of Motor & Cable:

Pump: <u>P-1</u>	R(2)~W(3)_____Ω	W(3)~B(1)_____Ω	B(1)~R(2)_____Ω
Pump: <u>P-2</u>	R(2)~W(3)_____Ω	W(3)~B(1)_____Ω	B(1)~R(2)_____Ω
Pump: <u>P-3</u>	R(2)~W(3)_____Ω	W(3)~B(1)_____Ω	B(1)~R(2)_____Ω

Sensor Loop Resistance:

Pump: <u>P-1</u>	Thermal_____Ω	Seal Test_____Ω
Pump: <u>P-2</u>	Thermal_____Ω	Seal Test_____Ω
Pump: <u>P-3</u>	Thermal_____Ω	Seal Test_____Ω

Insulation Resistance to ground (YEL/GRN-FLYGT PUMPS ONLY):

Pump: <u>P-1</u>	R(2)~GRD_____MΩ	W(3)~GRD_____MΩ	B(1)~GRD_____MΩ
Pump: <u>P-2</u>	R(2)~GRD_____MΩ	W(3)~GRD_____MΩ	B(1)~GRD_____MΩ
Pump: <u>P-3</u>	R(2)~GRD_____MΩ	W(3)~GRD_____MΩ	B(1)~GRD_____MΩ

*Note: This value should exceed 10 MΩ.*

**5. OPERATIONAL CHECKS**

1. Supply Voltage, Pumps Off:

L1 ~ L2: \_\_\_\_\_V L2 ~ L3: \_\_\_\_\_V L1 ~ L3: \_\_\_\_\_V

a. Do the above meet the approved scope of supply?

**Yes**       **No (Explain in Comments)**

2. Phase monitor settings: Voltage: \_\_\_\_\_, Delay: \_\_\_\_\_, % Imbalance: \_\_\_\_\_

3. Starter Type/Mfg./Model: \_\_\_\_\_

4. O.L. Type/Setting: \_\_\_\_\_ Amp \_\_\_\_\_

5. Impeller Rotation (CW/CCW) viewed from \_\_\_\_\_:

P-1: \_\_\_\_\_, P-2: \_\_\_\_\_, P-3: \_\_\_\_\_,

6. Volts, Pump Operating in System: Pump: 1 T1~T2 \_\_\_\_\_V T2~T3 \_\_\_\_\_V T3~T1 \_\_\_\_\_V

Pump: 2 T1~T2 \_\_\_\_\_V T2~T3 \_\_\_\_\_V T3~T1 \_\_\_\_\_V

Pump: 3 T1~T2 \_\_\_\_\_V T2~T3 \_\_\_\_\_V T3~T1 \_\_\_\_\_V

7. Amps, Pump Operating in System: Pump: 1 T-1 \_\_\_\_\_A T-2 \_\_\_\_\_A T-3 \_\_\_\_\_A

Pump: 2 T-1 \_\_\_\_\_A T-2 \_\_\_\_\_A T-3 \_\_\_\_\_A

Pump: 3 T-1 \_\_\_\_\_A T-2 \_\_\_\_\_A T-3 \_\_\_\_\_A

8. Abnormal noise/vibration?

P-1:  **Yes**       **No**       **NA**

P-2:  **Yes**       **No**       **NA**

P-3:  **Yes**       **No**       **NA**

9. Does pump shut down and lockout when sensor lead(s) are disconnected?

P-1:  **Yes**       **No**       **NA**

P-2:  **Yes**       **No**       **NA**

P-3:  **Yes**       **No**       **NA**

10. Have VFD's been programmed and do they work correctly (if applicable)?

P-1:  **Yes**       **No**       **NA**

P-2:  **Yes**       **No**       **NA**

P-3:  **Yes**       **No**       **NA**

11. List of VFD parameters has been provided (if applicable) to: \_\_\_\_\_

12. Has controller been programmed and is it working correctly (if applicable)?

**Yes**       **No**       **NA**

13. List of controller parameters provided to: \_\_\_\_\_
14. Does the primary level control system work correctly? Pump On/Off Points \_\_\_\_\_  
 Yes       No (Explain in Comments)
15. Does the hi level warning work correctly?  
 Yes       No
16. Does the redundant level control system work correctly (if applicable)?  
 Yes       No       NA
17. Does flow meter work correctly (if applicable)?  
 Yes       No       NA
18. Has the auto dialer been powered up and does it work correctly (if applicable)?  
 Yes       No       NA
19. Has disconnect panel been installed and does it work correctly (if applicable)?  
 Yes       No       NA
20. Has all I/O been checked out and verified?  
 Yes       No
21. Have all communication issues been tested & signed off by owner/contractor?  
 Yes       No       NA

**6. DRAW DOWN TEST:**

Gallons per foot:    4' diameter = 94 gallons  
                               5' diameter = 146.88 gallons  
                               6' diameter = 211.51 gallons  
                               8' diameter = 376.01 gallons  
                               10' diameter = 587.52 gallons

Draw down:            P-1: \_\_\_\_\_ FT  
                               P-2: \_\_\_\_\_ FT  
                               P-3: \_\_\_\_\_ FT

Pump flow:            P-1: \_\_\_\_\_ GPM  
                               P-2: \_\_\_\_\_ GPM  
                               P-3: \_\_\_\_\_ GPM

**\* DOES THE ABOVE MEET THE APPROVED SCOPE OF SUPPLY?**

**YES \_\_\_ NO \_\_\_ EXPLAIN IN COMMENTS**

**7. PRESSURE READINGS (IF AVAILABLE):**

Pump 1 - Pump off \_\_\_\_\_ psi. Pumping \_\_\_\_\_ psi. Pump on with valve closed \_\_\_\_\_ psi.  
 Pump 2 - Pump off \_\_\_\_\_ psi. Pumping \_\_\_\_\_ psi. Pump on with valve closed \_\_\_\_\_ psi.  
 Pump 3 - Pump off \_\_\_\_\_ psi. Pumping \_\_\_\_\_ psi. Pump on with valve closed \_\_\_\_\_ psi.

**8. WET WELL PRIMARY LEVEL SETTINGS:**

High/high level alarm:	Elevation_____	ft.
	Distance measured from floor_____	ft.
High level alarm:	Elevation_____	ft.
	Distance measured from floor_____	ft.
Lag/third pump start:	Elevation_____	ft.
	Distance measured from floor_____	ft.
Lag/second pump start:	Elevation_____	ft.
	Distance measured from floor_____	ft.
Lead pump start:	Elevation_____	ft.
	Distance measured from floor_____	ft.
Lag/third pump stop:	Elevation_____	ft.
	Distance measured from floor_____	ft.
Lag/second pump stop:	Elevation_____	ft.
	Distance measured from floor_____	ft.
Lead pump stop:	Elevation_____	ft.
	Distance measured from floor_____	ft.
Low level alarm:	Elevation_____	ft.
	Distance measured from floor_____	ft.

**\* DOES THE ABOVE MEET THE APPROVED SCOPE OF SUPPLY?**

**YES \_\_\_ NO \_\_\_ EXPLAIN IN COMMENTS**

**9. WET WELL SECONDARY LEVEL SETTINGS:**

Pumps Start: Elevation\_\_\_\_\_ft.

Pumps stop: Distance measured from floor \_\_\_\_\_ ft.  
Elevation \_\_\_\_\_ ft.  
Distance measured from floor \_\_\_\_\_ ft.

High level alarm: Elevation \_\_\_\_\_ ft.  
Distance measured from floor \_\_\_\_\_ ft.

Do all level settings match worksheet values?

Yes       No

**\*DOES THE ABOVE MEET THE APPROVED SCOPE OF SUPPLY?**  
**YES \_\_\_\_\_ NO \_\_\_\_\_ EXPLAIN IN COMMENTS**

COMMENTS



LIST ANY CORRECTIVE ACTION REQUIRED AND LIST RESPONSIBLE PARTY

10. **The Romtec Utilities technician PERFORMED ALL OF THE FOLLOWING start-up activities**

1. Verify electrical supply voltage.
2. Field check control panel.
3. Perform start-up procedure for pumps.
4. Set level controls per approved scope of supply.
5. Testing of pumping rate to the expected performance curve.
6. Field check and set back up power (generators) by Romtec Utilities (IF APPLICABLE).

All parties agree that Romtec Utilities has fulfilled all requirements (1-6) for this lift station, and the station is fully approved and commissioned.

Startup Technician:

Print Name: \_\_\_\_\_

Sign: \_\_\_\_\_

Cell Phone Number: \_\_\_\_\_

Date: \_\_\_\_\_

Contractor's Representative:

Print Name: \_\_\_\_\_

Sign: \_\_\_\_\_

Cell Phone Number: \_\_\_\_\_

Date: \_\_\_\_\_

Electrical Contractor Representative:

Print Name: \_\_\_\_\_

Sign: \_\_\_\_\_

Cell Phone Number: \_\_\_\_\_

Date: \_\_\_\_\_

Site Engineer Representative:

Print Name: \_\_\_\_\_

Sign: \_\_\_\_\_

Cell Phone Number: \_\_\_\_\_

Date: \_\_\_\_\_

Owner/Sewer Agency Representative:

Print Name: \_\_\_\_\_

Sign: \_\_\_\_\_

Cell Phone Number: \_\_\_\_\_

Date: \_\_\_\_\_

Lead Maintenance/Service Personnel:

Print Name: \_\_\_\_\_

Sign: \_\_\_\_\_

Cell Phone Number: \_\_\_\_\_

Date: \_\_\_\_\_

Startup witnessed by:

Print Name: \_\_\_\_\_

Sign: \_\_\_\_\_

Cell Phone Number: \_\_\_\_\_

Date: \_\_\_\_\_

Startup witnessed by:

Print Name: \_\_\_\_\_

Sign: \_\_\_\_\_

Cell Phone Number: \_\_\_\_\_

Date: \_\_\_\_\_

Startup witnessed by:

Print Name: \_\_\_\_\_

Sign: \_\_\_\_\_

Cell Phone Number: \_\_\_\_\_

Date: \_\_\_\_\_

**11. Who is the main contact to be in charge of operation and maintenance of the lift station through the duration of the warranty period:**

Name: \_\_\_\_\_

Company: \_\_\_\_\_

Phone: \_\_\_\_\_

Note:        *This person is responsible for troubleshooting with the help of Romtec Utilities over the phone in the event of a warranty issue throughout the one year warranty period beginning the day Start up Training is completed.*

Special Note:        *All other personnel relevant to the maintenance and operation of the lift station are required to be present for the duration of startup training.*

**END  
OF  
SECTION**

## **16. AUTODESK DESIGN REVIEW**

This section explains how to use the file extension DWF that should be attached to this submittal.

### **16.01 AUTODESK DESIGN REVIEW DOWNLOAD PROCEDURE**

## 16.01

## AUTODESK DESIGN REVIEW

included with your ROMTEC Utilities, Inc. Submittal is a file with the extension DWF.

The DWF file is a viewable 3D model of your actual system. To view the file, download the free software following the procedure below.

### **Autodesk Design Review Download Procedure:**

1. Go to: [www.autodesk.com](http://www.autodesk.com)
2. Click on: Autodesk Design Review Free tab located on the right of the page
3. Select the correct language and click Download Now
4. Select Save File
5. Go to the folder you downloaded the program to and double click the file AutodeskDesignRevSetup.exe
6. Click on Run
7. Follow the Installation Tips on the screen

To view and manipulate your .DWF file double click on the .DWF file

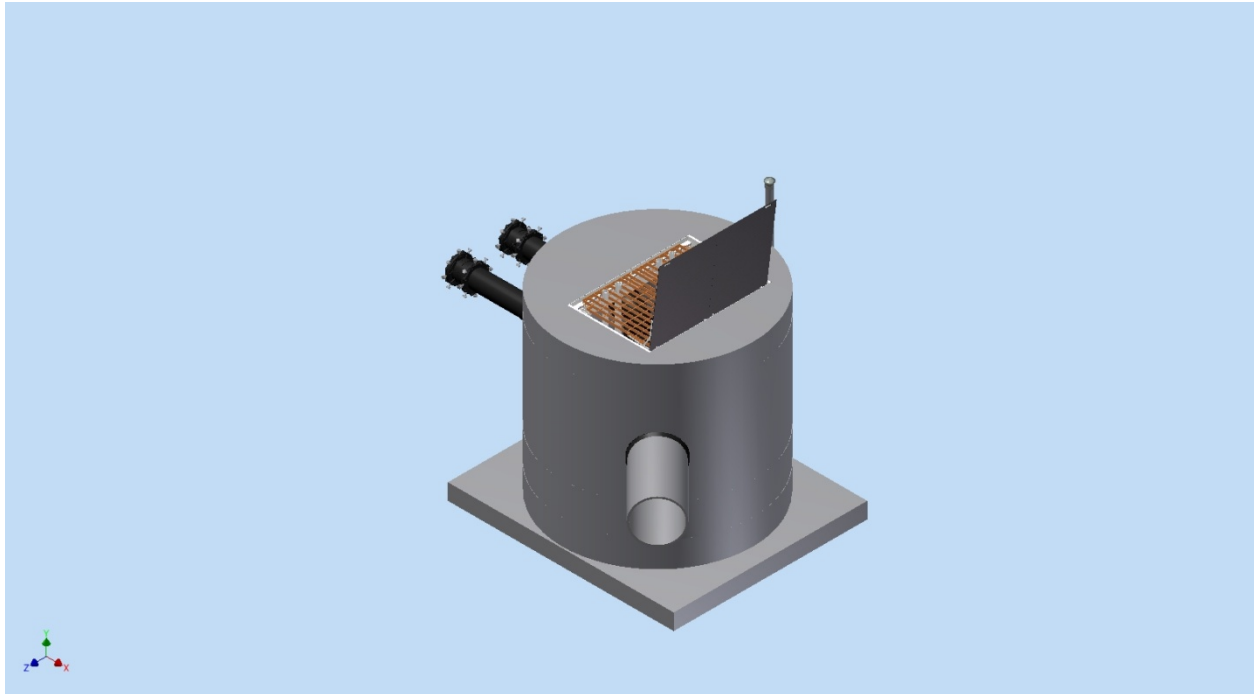

**END  
OF  
SECTION**