



## HOMMEL-ETAMIC AG100 Air tooling for measurement of inside diameters



Precision is our business.



## Your partner for industrial metrology

Hommel-Etamic, the Industrial Metrology Division of the Jenoptik group is a leading manufacturer and system provider of high-precision, tactile and non-tactile production metrology.

The range of products provided includes total solutions for a wide range of measurement tasks such as testing surfaces, form and determining dimensional tolerances – throughout all phases of the production process, for final inspection or in a metrology lab. Our product portfolio is rounded off by a wide range of services in consulting, training and service, including long-term maintenance contracts.

Hommel-Etamic. Precision is our business!

### Pneumatic precision – HOMMEL-ETAMIC AG100

Hommel-Etamic has been successfully developing and manufacturing pneumatic (air) tooling for over 60 years and our impressive global sales figures in this industry speaks for itself.

Thanks to modern day materials technology Hommel-Etamic air spindles are extremely robust, making them ideal for measuring workpieces that are subject to extremely harsh manufacturing and operating conditions (e.g. nuclear, automotive, aviation, medical, etc). In addition, our application of the pneumatic principle eliminates any special maintenance processes – a simple cleaning is all the tooling requires.

Standard air tooling can be modified for the length and position of the air jets. In addition, Hommel-Etamic develops and manufactures part-specific air tooling capable of measuring diameters as small as 1 mm and as large as 600 mm.

# Tooling with open air jets for bores

## Reliability and quality

Hommel-Etamic air spindles are extremely reliable, and in terms of precision and repeat accuracy (below 0.25 µm) can outperform comparable tactile gauging systems. Precision manufacture of each spindle is held to such a tight tolerance that the spindles can be replaced without compatibility issues, making it easy to verify gauging component capability.

## Static or dynamic measurements

AG100 tooling with open air jets are primarily used to measure through-bores or ultra-precision blind-hole bores. The diameter is established using two diametrically opposed, non-contact air jets, offset against the outer guide diameter of the air spindle. Measurements can take place either statically or dynamically.

## Mounted or mobile operation

AG100 air tooling can be used hard mounted inline or on a bench, as well as on semi-portable handles for operational flexibility. Part insertion is simplified using mathematically calculated diameters based off the measuring range of the air tooling.

## Extremely robust

Robust in design and manufacture, AG100 air tooling can be used to measure hundreds of thousands of workpieces with no loss in measuring accuracy. Each one is manufactured from hardened steel (59/62 HRC), or surface-treated steel (55/57 HRC), making them particularly suitable for use in harsh manufacturing environments.

## Simple calibration

Normal air tooling is typically calibrated using minimum and maximum reference rings (masters) of known dimensions. The impressive linearity of Hommel-Etamic measuring chains allows AG100 systems to be calibrated using only one master, making the use (and expense) of maximum and minimum masters unnecessary.

## Universal application

AG100 air tooling is ideal for manual measurement of bores in production lines, for automatic or semi-automatic measuring stations, and for the quality lab (subgroups or 100% monitoring).

## Error measurement

The spindle is rotated in the workpiece to determine out-of-roundness and moved to determine conicity. On request, the air spindle can be fitted with three jets for measurement at three separate points (3x120°).

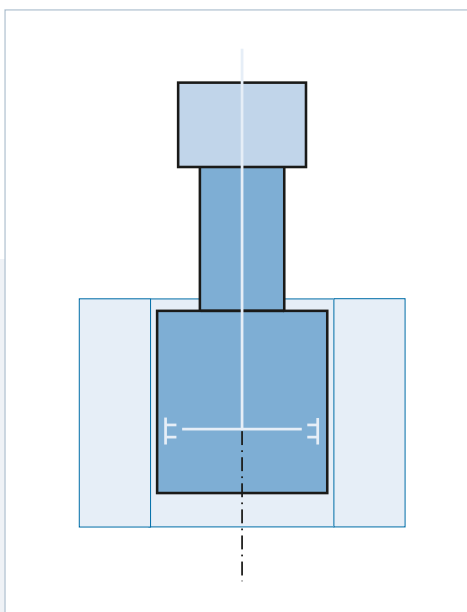

Measuring principle

## Application examples

- Gearbox housing block
- Steering block
- Cylinder block
- Injection pump
- Injection nozzle
- Pump nozzle
- Engine blade
- Con rod
- Piston
- Toothed wheel
- Brake master cylinder
- Turbo block etc.

# A wide range of air tooling

Our standard air tooling sizes range from 3 mm to 150 mm in diameter, with measuring ranges of 0.010 mm to 0.160 mm respectively (typically measuring ranges should be at least equal to, or double, the size of the tolerance for the bore to be measured).

There are four different standard types of air jets utilized on AG100 spindles (round # 1, round # 2, elongated # 2 or elongated # 5). The type of jets used depends on the diameter, the surface structure of the workpiece to be measured, and the required measuring range (i.e. elongated air jets are used to reduce the impact of surface roughness on the measurement result).

The position of the air jets depends on the type of spindle being used and the nominal diameter to be measured. There are two types of tooling: 'S' (standard for through bores) and 'TP' (jets located near the spindle end for blind-hole bores). All Hommel-Etamic

air tooling are equipped with a pre-guidance in order to facilitate their introduction into the bore and have a unique identifier engraved on them.

## Applications with Hommel-Etamic measuring instruments

The air tooling can be connected to all Hommel-Etamic measuring instrumentation.

In the case of portamic, C61 or pneumatic displays, the AG100 air spindles are directly connected to each device.

Alternatively, they can be used indirectly via an electro pneumatic converter (ARC99, TPE99 or TPE70/3).

In this case, the measurement results can be displayed on an ESZ800, CMZ200, CMZ250 or ESZ400 measuring computer.



Use with HOMMEL-ETAMIC CMZ250 measuring computer



Use with HOMMEL-ETAMIC pneumatic display unit

# Properties of standard air tooling

## Measuring range

Diameter (mm)	Jet type			
	Round air jet # 1	Round air jet # 2	Elongated air jet # 2	Elongated air jet # 5
3 < ØN ≤ 6	Maximum measuring range = 0.060 mm	Not available	Not available	Not available
6 < ØN ≤ 12	Maximum measuring range = 0.080 mm	Maximum measuring range = 0.160 mm	Maximum measuring range = 0.040 mm	Maximum measuring range = 0.080 mm
12 < ØN ≤ 25				
25 < ØN ≤ 80				
80 < ØN ≤ 150				

## Precision and performance

The outstanding precision delivered by our products supports compliance with the most stringent performance standards: CMC, GR&R, Cg, Cgk etc.

Measuring range (mm)	Accuracy	Performance	
		GR&R type 2	CMC
0.010 (±0.005)	< 0.00025	< 10%	2
0.020 (±0.010)	< 0.0005		
0.040 (±0.020)	< 0.001		
0.060 (±0.030)	< 0.0015		4
0.080 (±0.040)	< 0.002		
0.120 (±0.060)	< 0.003		
0.160 (±0.080)	< 0.004		

## Guide diameter

The guide diameter is the actual diameter of the air spindle. It depends on the selected capacity, the jet type, and the nominal diameter of the dimension to be measured.

Measuring range (mm)	Guide diameter with				Tolerance (mm)
	2 round air jets # 1	2 round air jets # 2	2 elongated air jets # 2	2 elongated air jets # 5	
0.010 (±0.005)	ØN - 0.012	ØN - 0.012	ØN - 0.012	ØN - 0.012	±0.002
0.020 (±0.010)	ØN - 0.018	ØN - 0.020	ØN - 0.018	ØN - 0.020	±0.003
0.040 (±0.020)	ØN - 0.030	ØN - 0.035	ØN - 0.030	ØN - 0.035	±0.005
0.060 (±0.030)	ØN - 0.040	ØN - 0.045	–	ØN - 0.045	±0.005
0.080 (±0.040)	ØN - 0.050	ØN - 0.055	–	ØN - 0.055	±0.005
0.120 (±0.060)	–	ØN - 0.075	–	–	±0.005
0.160 (±0.080)	–	ØN - 0.095	–	–	±0.005

# Overview of standard air tooling

'S' air spindles  
with standard jets

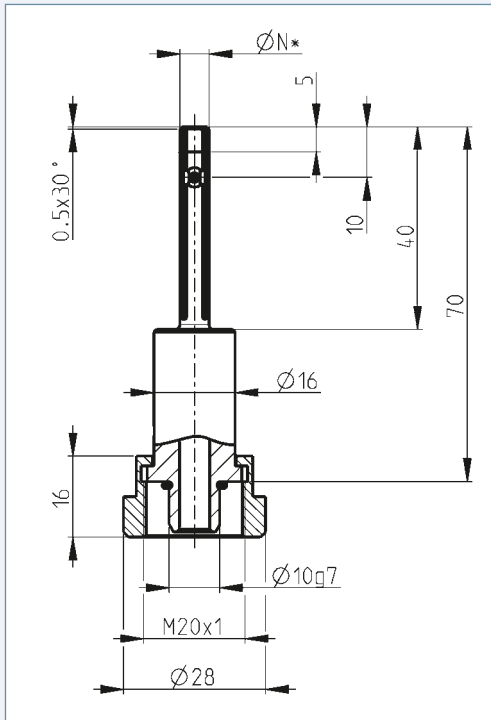

AG100-S-3-6; diameter  $3 < \text{ØN} \leq 6$  mm

'TP' air spindles  
with jets near the end

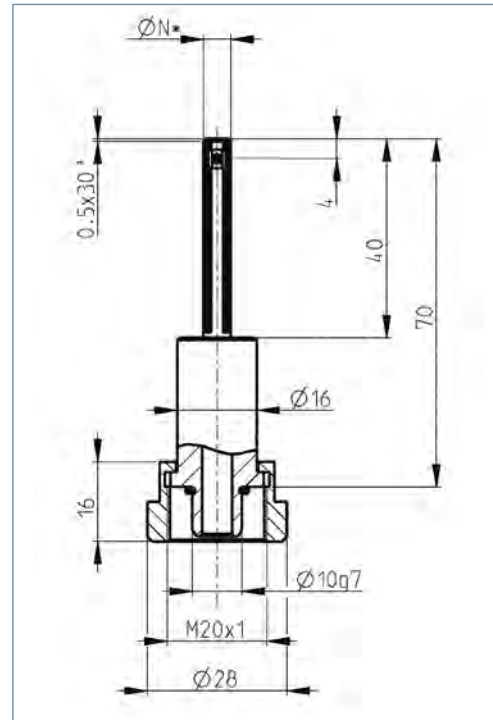

AG100-TP-3-6; diameter  $3 < \text{ØN} \leq 6$  mm

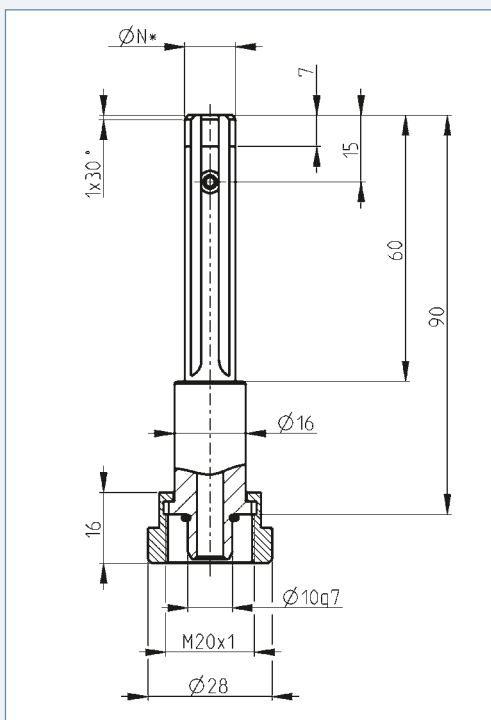

AG100-S-6-12; diameter  $6 < \text{ØN} \leq 12$  mm

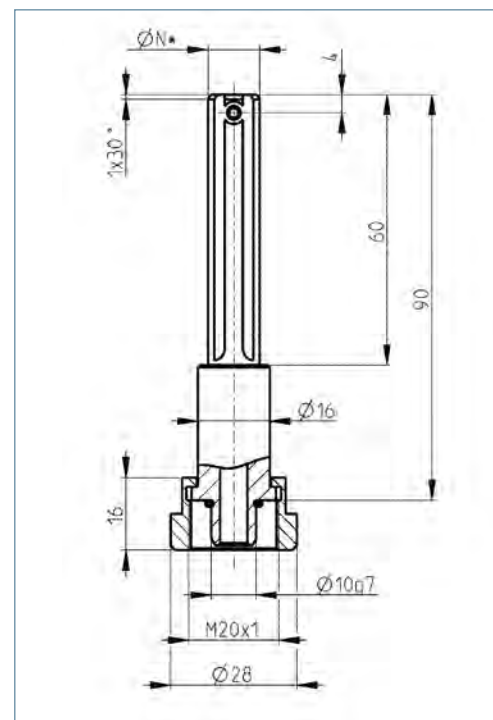

AG100-TP-6-12; diameter  $6 < \text{ØN} \leq 12$  mm

„S“ air spindles  
with standard jets

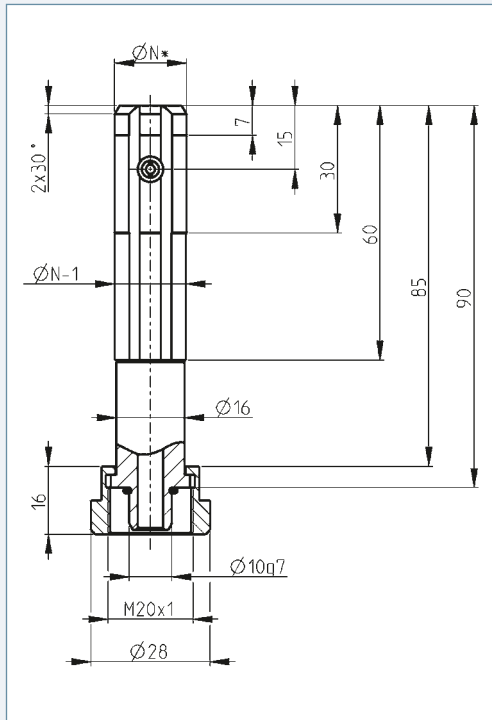

AG100-S-12-25; diameter  $12 < \varnothing N \leq 25$  mm

„TP“ air spindles  
with jets near the end

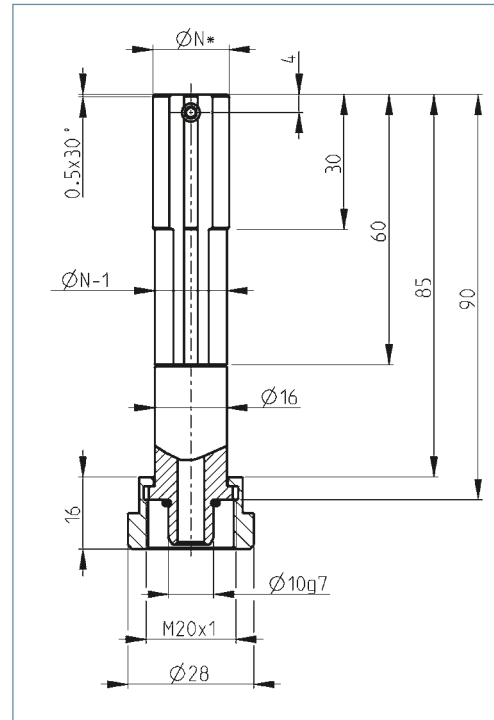

AG100-TP-12-25; diameter  $12 < \varnothing N \leq 25$  mm

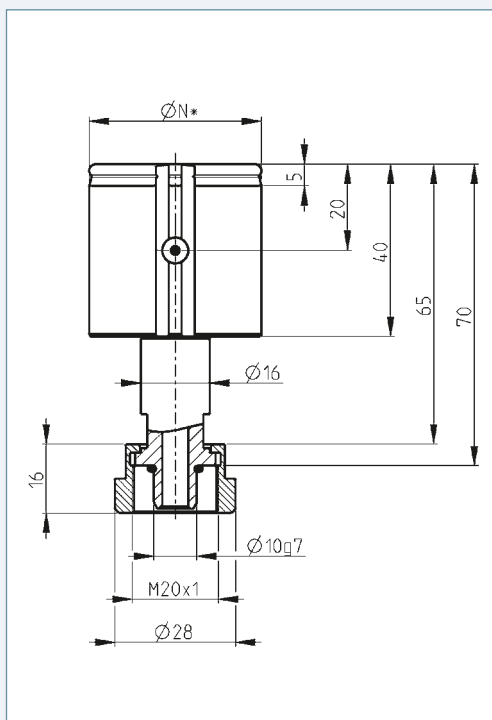

AG100-S-25-80; diameter  $25 < \varnothing N \leq 80$  mm

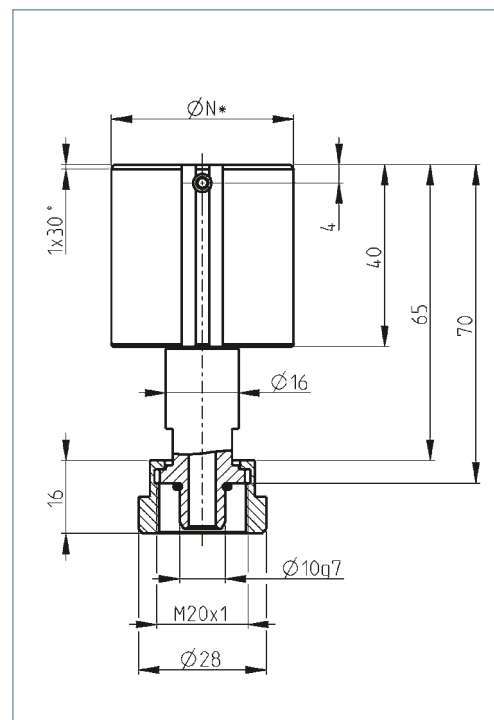

AG100-TP-25-80; diameter  $25 < \varnothing N \leq 80$  mm

# Overview of standard air tooling

## 'S' air spindle with standard jets

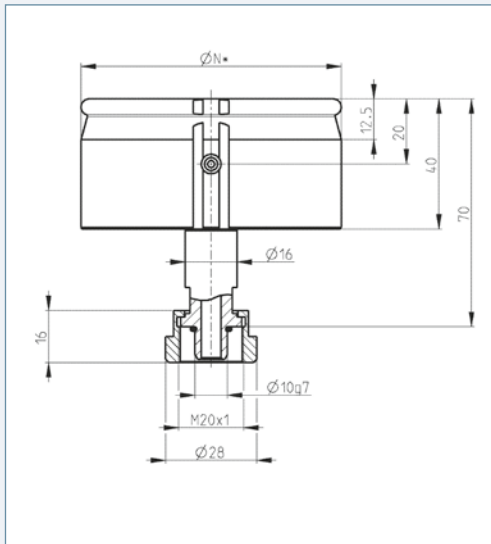

AG100-S-80-150; diameter  $80 < \varnothing N \leq 150$  mm

## 'TP' air spindle with jets near the end

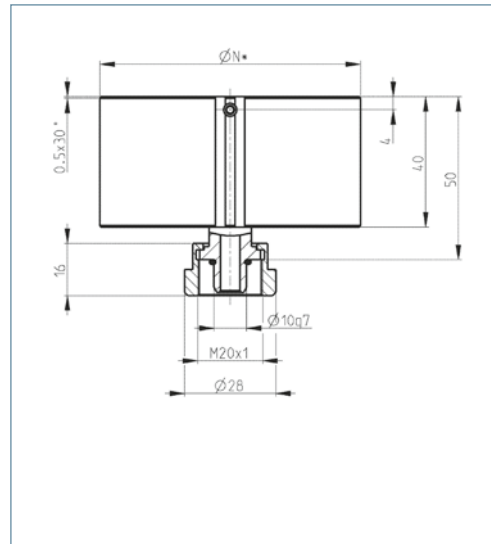

AG100-TP-80-150; diameter  $80 < \varnothing N \leq 150$  mm

## Accessories

### Stop collar

This collar is used when measuring at specific positions in a bore (manually adjustable); it improves the repetitive accuracy of the air spindle. The dimensions depend on the diameter of the spindle.

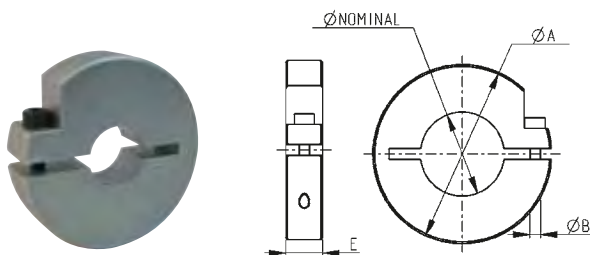

Art. no.	Diameter (mm)	$\varnothing A$	$\varnothing B$	E
E307539-000	$3 < \varnothing N \leq 5$	16	M2	6
E307695-000	$5 < \varnothing N \leq 12$	29	M3	10
E307718-000	$12 < \varnothing N \leq 20$	39	M3	10
E307719-000	$20 < \varnothing N \leq 30$	49	M3	10
E319102-000	$30 < \varnothing N \leq 40$	69	M5	10
E319103-000	$40 < \varnothing N \leq 50$	79	M5	10
E319104-000	$50 < \varnothing N \leq 60$	89	M5	10
E319105-000	$60 < \varnothing N \leq 70$	99	M5	10
E319106-000	$70 < \varnothing N \leq 80$	109	M5	10
E319107-000	$80 < \varnothing N \leq 90$	119	M5	10
E319108-000	$90 < \varnothing N \leq 100$	129	M5	10
E319109-000	$100 < \varnothing N \leq 115$	144	M5	10
E319110-000	$115 < \varnothing N \leq 130$	159	M5	10
E501006-000	$130 < \varnothing N \leq 150$	179	M5	10



# Accessories

Handle with flexible hose and M20x1 plug-in connection

The handle makes it possible to use the air spindle manually and makes handling, with or without protective gloves, simpler. The type of flexible hose required is determined on the basis of which pneumatic design the spindle features:

Hose length / hose diameter	1 m	1.5 m
4 mm	E500096-100	E500096-150
5 mm	E500097-100	E500097-150
6.5 mm	E500098-100	E500098-150
8 mm	E500099-100	E500099-150

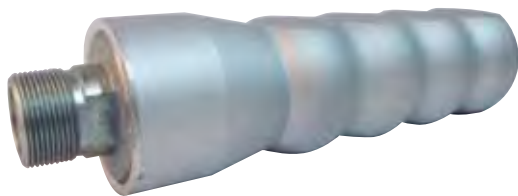

## Mini handle

Developed specifically for air tooling with a small diameter (< 6 mm), for areas that are hard to access. M20x1 plug-in connection.

E500221-100



## O ring

For sealing the connection between the spindle nut and the handle connection piece, the adapter or the base.

X470004-153



Adapter M14x1 plug-in connection-M20x1 plug-in connection

Facilitates fitting of the latest-generation air spindles to a C61 display unit or a TPE70 converter (screw thread M14x1). E501000-000



Adapter 1/4 BSP plug-in connection-M20x1 plug-in connection

Facilitates direct connection of an air spindle to a TPE99 converter or a pneumatic display unit (screw thread 1/4 BSP). E500069-000



Spindle extension M20x1 plug-in connection-M20x1 socket

For taking measurements in very long bores or those that are hard to access.

E500073-000



Replacement nut M20x1 socket

E500070-000



# Accessories

## Storage device

Used for storing the air spindle when not in use. This accessory can also be fitted with an available air saving device featuring a switch-controlled pneumatic valve that automatically turns the air supply off or on.

Storage device  
E501194-000



## Air spindle base

Used if the workpiece to be measured is light, as the measurements should ideally be performed using a spindle that is attached to a table. Secured using two M6 bolts and available in two versions:



90° base  
E500119-000



45° base  
E500119-002

## Air spindle base with jet block

Reduces the pneumatic response time between the spindle and the controller, when performing dynamic measurements.

90° base with jet block  
E500119-001

45° base with jet block  
E500119-003



Storage device with pneumatic  
switch E501194-050

Examples of air tooling mounted on a base





## Air spindle selection

To ensure the selection of the best possible air spindle for your application, the following information is required:

- Drawing of the workpiece to be measured
- Diameter, tolerance, and surface structure of the bore to be measured
- Type of bore (through-bore or blind-hole bore)
- Type of material required for the air spindle: hardened steel (100,000 workpieces to be measured) or surface-treated steel (1,000,000 workpieces to be measured)
- Required measuring range (see measuring range table on page 5)
- Pneumatic combination, if the air spindle is to be connected to an existing device

Our specialist consultants will be happy to answer any questions you may have to help you determine which air spindle is best suited for your application.

We look forward to hearing from you!

HOMMEL-ETAMIC France SA  
ZA Damigny, Rue de la Cartoucherie  
Saint-Martin-des-Entrées, BP 61080  
14406 Bayeux Cedex, France  
Phone +33 231 51 3751  
Fax +33 231 21 1361  
Email [info.fr@hommel-etamic.com](mailto:info.fr@hommel-etamic.com)



## Our global presence.

Germany	Spain	Mexico
France	Czech Republic	China
Switzerland	United States	South Korea
		India

Group companies, affiliates and representation worldwide

[www.hommel-etamic.com](http://www.hommel-etamic.com)