

2017 Portable collection

Portable Display Systems - Outdoor Displays - Modular Stands

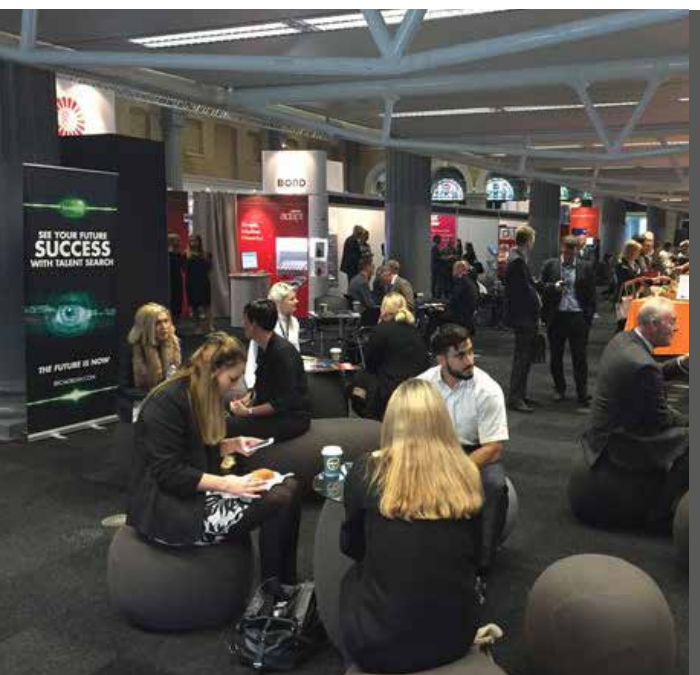

miragedisplay.co.uk



About **Mirage**

Full service display company

Pages 04-05

- About us **04**
- Warranty
- Storage
- Install
- Artwork **05**
- Design
- Production

The collection

01

Portable display systems

Pages 06-75

- Pop up displays **06**
- Roller banners **09**
- Linked banners **27**
- Static displays **35**
- iPad displays **46**
- Towers **50**
- Literature stands **54**
- Tabletop stands **57**
- Fabric stands **60**
- Formulate fabric **66**
- Counters **72**
- Podiums **74**

02

Outdoor displays

Pages 77-89

- Sail banners **78**
- Pop up A-Frames **79**
- Outdoor shelter **80**
- Outdoor displays **84**
- Outdoor banner stands **86**
- Pop Inflatables **88**
- Race arches **89**

03

Modular stands

Pages 91-107

- Modular Options **92**
- Twist Modular **92**
- Centro modular **93**
- Impact modular **94**
- Custom flooring **96**
- Stretch fabric **97**
- Clever Frame **98**
- Gantry modular **100**
- T3 Shell Clad **101**
- T3 modular system **102**
- ISOframe Wave **104**
- Linx premium **106**

Full service display company

- Wide range of portable display systems from banner stands through to pop up display stands and modular reusable exhibition stands
- Range of display stands suitable for both indoor and outdoor use
- Graphic panels for display systems
- Graphic panels for existing display systems
- In-house design services
- Storage and distribution
- Demonstration of display systems
- Installation and breakdown of display and exhibition stands
- 3D design and visualisation service
- In-house design team - no out-sourcing design to external companies
- Fast turnaround available
- Production of posters, hanging graphic panels and PVC banners.
- Canvas Prints

Warranty

Our range of display stands are all supplied with warranties against product failure or manufacturing defects. The length of warranty differs between products, with premium products supplied with a lifetime guarantee on hardware and lower cost stands with a five year guarantee on hardware. Our sales consultants will recommend the best display system which meets your usage requirements.

Storage

We have extensive storage facilities, and are able to store our customers' display stands for short or long term periods. We can organise UK and worldwide deliveries to take the hassle of logistics and transportation out of our clients hands. After return to our storage facility, all display stands are checked and any repairs carried out, to ensure that your display stands last for years and are in good condition.

Installations

We have a installation team who can install large bespoke exhibition stands down to pop up stands or banner stands. We can install your display stands anywhere in the UK, and our experience will ensure a hassle free service. We pre-build stands at our production building to ensure that all stands can be set up on-site quickly and ensure that everything looks and works perfectly prior to install. We can also dismantle your stands, and return to our warehouse for use at your next event.

Artwork, design & production

To ensure that our displays achieve the maximum possible impact and look their best we offer a dedicated design service. We handle all production at our specialist in-house facility.

Our long experience in the display market means that you can be confident of gaining a high quality promotional tool. This can be updated as your brand and marketing messages change over the years to come.

Our large open plan modern studio allows our creative team the chance to achieve their maximum ability and to produce outstanding quality graphics, which you, our customer will be happy with.

Nothing looks worse than an exhibition stand which thinks its a brochure. Our specialist design service can advise you on how best to achieve a memorable and effective display. We aim to ensure that your portable exhibition solution becomes a valuable marketing tool.

Following your initial enquiry we will forward you an outline of a brief listing the relevant information which we require from you.

We will then follow this brief and submit our initial proposals, usually as high quality Acrobat PDF files which you can view on your computer.

We can also supply colour proofs if required.



Impact Xpress pop up

Straight or Curved



3x3 Curved

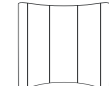

3x3 Straight

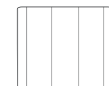

4x3 Curved

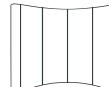

4x3 Straight



Halogen lamp kit

- 2 x 150w lamps
- Power leads
- UK plug fitting



Zeus case

- Storage for 3x3 or 4x3 system
- Converts into a handy podium
- Includes graphic panel
- Includes wooden tabletop

Impact™ Xpress is the cheapest of our Impact™ Pop Up displays. Ideal for those seeking an entry level pop up exhibition display stand. Impact™ Xpress has many features not available with other similar priced pop up stands. Graphic panels are produced using the same materials and process as our more expensive Impact™ stands. Available 2.25m high or 1.85m high with either a curved or straight frame. Impact™ Xpress comes with fittings on the rear for optional back panels to create a 360 degree display stand.

- Magnetic self locking device makes frame assembly quick and easy
- Available curved or straight
- Available in a standard 2.25m height or midi 1.85m height
- New magnetic fittings on bars make for simple set up
- Fittings for optional rear panels
- Secure graphic panel fittings
- Low cost pop up exhibition display stand
- 5 year manufacturer's warranty on hardware
- High impact graphic panels supplied in individual sleeves
- Setup within 15 minutes
- Our lowest cost pop up stand

Impact Original pop up

Straight or Curved



Magnetic Panel Fitting



Screen Holder



All in One Case

- Storage for 3x3 or 4x3 system
- Converts into a handy podium
- Includes graphic panel
- Includes wooden tabletop

Impact™ Original is the best selling display stand within our Display range of pop up display stands. This is the most popular of our Impact™ range, and is used by many of the UK's leading brands. Precision engineered magnetic fittings ensure the panels locate to the correct position on the frame. When you need to set up your exhibition display stands quickly and easily, without a fuss, Impact™ Original is the perfect solution. Available with a curved or straight frame, with the option for rear graphic panels. Impact™ Original is also available with a fitting for an LCD screen.

- Magnetic self locking device makes frame assembly quick and easy
- New magnetic fittings on bars make for simple set up
- Magnetic graphic fittings eliminate unsightly panel hooks
- Designed for seamless display
- Reinforced frame for a busy events calendar
- Lifetime manufacturer's warranty on hardware
- High Impact graphic panels supplied in individual sleeves
- Option to fit LCD screens
- Setup within 10 minutes

Impact Plus pop up

Straight or Curved



The ultimate in pop up exhibition display stands. Every component in the sleek Impact™ Plus pop up stand has been designed with a focus on durability and ease of use. An award winning product design sets Impact™ Plus apart from other pop up displays. This top of the range display stand makes no compromise on quality and will ensure years of trouble free intensive use. Available as a curved or flat frame. Red Dot Design award winner.

- Magnetic self locking device makes frame assembly quick and easy
- Next generation of pop up stands
- New magnetic fittings on bars make for simple display stand set up
- Magnetic graphic fittings eliminate un-sightly panel hooks
- Designed for seamless display
- Reinforced frame for a busy events calendar

- Lifetime manufacturer's warranty on hardware
- High Impact graphic panels supplied in individual sleeves
- Red Dot Design Award winner
- Foldable magnetic bars reduces components for easier and quicker display stand setup
- Setup within 10 minutes



reddot design award



Halogen lamp kit

- 2 x 150w lamps
- Power leads
- UK plug fitting



All in One Case

- Storage for 3x3 or 4x3 system
- Converts into a handy podium
- Includes graphic panel
- Includes wooden tabletop



Roller Banners & roller banner stands

We have a wide range of roller banner stands to cover different budgets and usage requirements.

Our range of roller banners are split into different price brackets from low cost budget roller banner stands to premium displays designed for intensive use with unique features.

Whether you're looking for a budget roller banner for occasional usage or are looking for something a little different in the form of our double sided roller banner stands, we're confident we are able to offer a solution to your requirements.

Our budget roller banners offer the ideal low-cost solution for those needing a simple means of displaying company information and offers in a range of situations.

Whilst our range of mid-range roller banner stands have been designed for more regular usage.

In addition to these, our premium roller banners all use telescopic poles, meaning you are able to adjust the height yourself as well as making for an easier setup. Our premium range is designed for companies who are looking for a banner stand which will last for years. We have many customers who order replacement graphic panels for their existing premium banner stands, ten years after the initial purchase..

Whatever your needs and requirements, our roller banner stands have been designed to cover all bases, offering competitively priced display solutions alongside the highest level of production.

We print all graphics ourself in house and have a dedicated team who are committed to ensuring you receive the finest product, whichever of our roller banner stands you choose to purchase.



Quality comes as standard

Many of our products come with lifetime or long guarantees. Visit our website or talk to our sales team to discover our after-sales difference. Individual information on each product is available, but we will always endeavour to help you maximise the life of your display system when possible.

Options something for every situation

£ Premium range

- Suitable for intensive use
- Hard wearing
- Telescopic poles for easy setup
- Hard wearing laminated finish

£ Mid Range range

- Suitable for regular use
- Quality product
- Change graphics over time
- Quality laminated finish

£ Budget range

- Suitable for occasional use
- Low cost
- Simple design
- Budget laminated finish



S1 roller banner



Our S1 Roll Up banner stands are a reliable and hard wearing roller banner stand. The Swedish designed premium banner stand is suited for companies looking for a durable, intensive use banner stand which will last for many years. The base unit and roller mechanism are manufactured from the highest quality materials to ensure this roll up banner stand will never need replacing.

- Red Dot Design Award winner
- Lifetime guarantee against hardware failure
- Telescopic pole for height adjustable panels
- High quality Swedish design
- Premium padded carry bag
- Available 85cm or 100cm wide



Quickscreen3 roller banner



Quickscreen3 banner stands ensure no hassle, easy set up roller banner displays. A telescopic pole makes for simple assembly, overcoming any unforeseen issues with height restrictions. Quickscreen3 is supplied with a patented quick removal cassette. Graphic panels can be swapped over quickly and without fuss making this display stand the ultimate quick change banner stand.

- Premium quality roller mechanism
- Removable cassette for quick change graphic panels
- Available 85cm or 100cm wide
- Telescopic pole up to 220cm high
- Base available with a choice of colours
- Premium carry bag



Coloured end caps

- Available with amber, red, clear, green, chrome, blue and grey end caps

Zap D2 roller banner



Panel width

- Panel width available 85cm or 120cm



Extra stability

- Long supporting middle foot for extra stability



Adjustable height

- Telescopic pole for height adjustable graphic panel

Colour choice

- Stylish black or chrome finish



Our Zap banner stands are one of our best selling roller display stands. The durable chrome end caps protect the display stand so it can be used for the most intensive of events calendars. All Zap stands are supplied with a lifetime guarantee against product failure. A unique telescopic pole allows for quick and easy set up, and height adjustable graphic panels. Available with premium 85cm or 120cm graphic panels. Zap banner stands have a facility for interchangeable graphic panels which can be swapped over in a few minutes. Zap D2 has a central foot for added stability.

- Premium quality banner stands
- Lifetime guarantee against hardware failure
- Stylish black or chrome finish
- Interchangeable graphic panels
- Adjustable feet for uneven floors
- Telescopic pole for height adjustable panels
- Premium padded carry bag
- Available 85cm or 120cm wide

Zap D3 roller banner



Panel width

- Panel width available 85cm or 120cm



Adjustable height

- Telescopic pole for height adjustable graphic panel



Extra stability

- Sloping base with deep foot footprint.



Colour choice

- Stylish black or chrome finish

Our Zap banner stands are one of our best selling roller display stands. The durable chrome end caps protect the display stand so it can be used for the most intensive of events calendars. All Zap stands are supplied with a lifetime guarantee against product failure. A unique telescopic pole allows for quick and easy set up, and height adjustable graphic panels. Available with premium 85cm or 120cm graphic panels. Zap banner stands have a facility for interchangeable graphic panels which can be swapped over in a few minutes. Zap D3 has a modern sloping base with a deep footprint.

- Premium quality banner stands
- Lifetime guarantee against hardware failure
- Stylish black or chrome finish
- Interchangeable graphic panels
- Adjustable feet for uneven floors
- Telescopic pole for height adjustable panels
- Premium padded carry bag
- Available 85cm or 120cm wide

Mediascreen XL roller banner



MediaScreen XL is an extra wide, extra tall retractable display that is exceptionally suitable when your message needs to be seen from a distance. You can also easily create an even larger image by linking two or more displays, thanks to a magnetic connector at the top. Three 100 cm displays, for example, can fit in a 10 foot wide space and can reach upto 3m high.

Graphic panels for the Mediascreen XL are printed on our full colour premium matt laminated graphic that gives excellent image quality and also a scuff resistant finish to protect the graphic panel for years. If you ever need to replace the graphics send the units back to us and we can print and refit new graphics.



Super sized

- High quality linkable roller is available in two widths, 100cm and 120cm. The real selling point of this banner is that it is available in four different heights; 200cm, 218cm, 250cm and the stratospheric 300cm high version!



Magnetic ends

- Magnetic end profiles so it is possible to link two or more together to create an impressive backdrop.



Quality assured

- Premium roller mechanism that will last for years.
- Supplied in a quality padded carry bag with shoulder straps.
- Spotlight option available if you want to illuminate your display.

Compact roll up



Compact Roll Up is a compact and simple to use roll up banner stand. The rounded corners and sides makes it simple and easy to handle. The base unit has protective edges to ensure this banner stand will be able to stand up to intensive use over many years. The adjustable telescopic pole allows for easy set up and a height adjustable graphic panel.

- 85cm or 100cm wide x up to 223cm high
- Lifetime guarantee
- Designed for intensive use
- Quick and simple set up
- Telescopic pole for easy set up

Bamboo roller banner



Think
Green

The Natural Choice

Suitable for variety of ethological and oriental themed messages

This popular environmentally friendly (made with 90% renewable bamboo) banner stand adds a touch of style to your brand and a touch of green.



- 850mm wide.
- Fixed height three piece wooden pole.
- Wooden twist out feet for stability.
- Padded carry bag included



Quickscreen roller banner



Halogen lamp kit

- Universal 50w low voltage spotlight



Durable and robust base unit

- Supplied with lifetime guarantee

Our Quickscreen banner stands are our best selling mid-range roller display stand. We have been selling the Quickscreen banner stand for over ten years, and it has proven to be a favourite with many of our clients. Quickscreen roller banners are a tried and tested, cost effective display stand. The reliable roller mechanism will ensure that they last for many years. The Quickscreen base unit comes with a lifetime guarantee against product failure.

- Available 85cm, 100cm or 120cm wide
- 200cm or 218cm high
- Tried and tested design
- Lifetime guarantee
- From 5.2kg
- Best selling mid range banner stand

Verve roller banner



Stylish finish

- Compact, sloping angled base finished with chrome effect end caps, to create a modern feel to this display stand
- The chrome end caps also protect the ends of the base unit, preventing problems with jamming the roller mechanism if dropped
- Base available silver or matt black
- Available 85cm, 100cm, 120cm or 150cm wide



The verve banner is a cost effective, mid ranged roller banner display stand. This is our narrowest footprint banner stand, that does not require a protruding foot to stabilise the stand. This is ideal for busy venues where they may be a concern about passers by tripping on a visible support foot.

Verve comes with a height adjustable telescopic support pole. As a result the Verve banner is more simple to set up than fixed pole height banner stands, as there is no requirement to be able to reach the top of the panel during set up. The telescopic pole to this banner stand also means that the panel can be adjusted from any height between 160cm and 220cm.

Evo roller banner



Simple setup

- Telescopic pole can be secured at a comfortable height for the user, and then extended to its full height.
- The full height of the graphic panel is 220cm high. Telescopic pole allows for the panel height to be reduced to any height from 160cm up to 220cm, therefore allowing for any low ceiling heights.



The Evo roller banner stand is a progression on the design of more functional banner stands. With the addition of chrome end plates and an attractive chrome finished support foot. This mid range display stand is ideal for companies looking the next step up from a standard roller banner stand. Evo has a good quality roller mechanism inside the base, which is suitable for regular use.

- 5 year guarantee against product failure
- Scuff resistant matt laminate panels
- Telescopic pole for height adjustable panels
- Premium padded carry bag
- Available 85cm, 100cm or 120cm wide

Merlin cassette banner



Our Merlin roller banner stand has a removable graphic panel cassette which is stored inside the base unit. This enables multiple graphic panels, each in its own cassette to be used with this system. Ideal for companies who need to change graphic panels quickly, without the need to have to send the unit back to us, to have new panels fitted.

- 5 year guarantee against product failure
- Quality banner stand
- Stylish Sloping Base
- Premium padded carry bag
- Available 85cm or 100cm
- Height 210cm



Elegant base

- The front sloping profile to the base means that no protruding foot is required to keep the banner stand stable.
- Ideal for companies who prefer to avoid unsightly feet, or where trip hazards are a particular concern.



Interchangeable panels

- Removable graphic panel cassette
- Quality banner stand that lasts for years and changes with your branding

Barracuda roller banner



Stylish base

- The base unit has a sloping front, which means no need for a protruding foot to keep it stable.
- Supplied in brushed aluminium with modern looking black end caps to finish the base unit off.

Easy set up

- The Barracuda has a height adjustable rear pole support that not only makes this roll up display stand easy to set up, the overall height can also be adjusted.
- Available in two widths of 800mm and 1000mm wide.

Accessories available

- The Barracuda has some optional accessories available to make this a unique banner display stand. A screen mount is available to fix an LCD screen to a frame structure behind the stand to allow you to add an audio visual element to your display.
- Also available are literature holders or shelving, that fit to framework on the left or right hand side of the graphic panel.

Popular Modern Roll Up Display Stand with 10 Year's of Progression
This stylish and popular roll up display stand has been on the market for over 10 years and has been constantly improved during that time. The Barracuda roll up banner is tried and tested and one of our most popular mid range banner stands.





Double Sided roller banners

Quickstand2 | Budget £



- Can be used single or double sided
- Low cost
- Available 85cm or 200cm high
- From 3.6kg
- Hardware comes with a 5 year guarantee

Verve2 | Mid Range £



- Can be used single or double sided
- Mid-range banner stand
- Available 85cm or 100cm wide x 200cm high
- From 8kg
- Hardware comes with a 5 year guarantee

Double Sided roller banners

Dual | Premium £



- Easily change graphics on-site
- Mid-range banner stand
- Available 85cm or 100cm wide x 215cm high
- From 7.5kg
- Hardware comes with a 5 year guarantee

Mediastand2 | Premium £



- Can be used single or double sided
- Premium banner stand
- Available 85cm wide x 215cm high
- From 8.5kg
- Hardware comes with a lifetime guarantee





Quickstand roller banner



Quickstand is one of our best selling roller banner stands. Although the cheapest banner stand in our range, we have avoided using low quality materials which are often associated with lower cost display stands. Available in a range of widths, Quickstand is a lightweight display which is easy to transport. Supplied with a two footed base unit for extra stability.

- Available 85cm, 100cm, 120cm and 150cm wide.
- Available 200cm high
- Weight from 3kg
- Cost effective banner stand
- Compact base for easy transportation

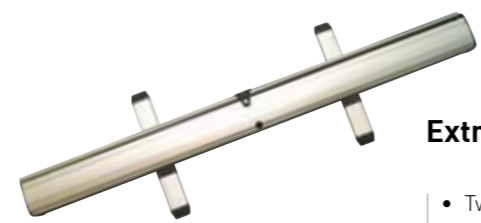

Extra stability

- Two feet for extra stability

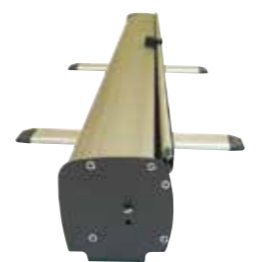

Square profile

- Simple and functional design

Prism roller banner



- Our entry level Roll Up has a modern design and sleek roller banner system.
- Designed for medium use, this banner display stand offers reliability and durability combined with reasonable pricing.



- Twin feet complete the look giving you a sturdy finish, supplied with a quality snug fit carry bag
- High-grade aluminium base, combined with good quality roller mechanism.



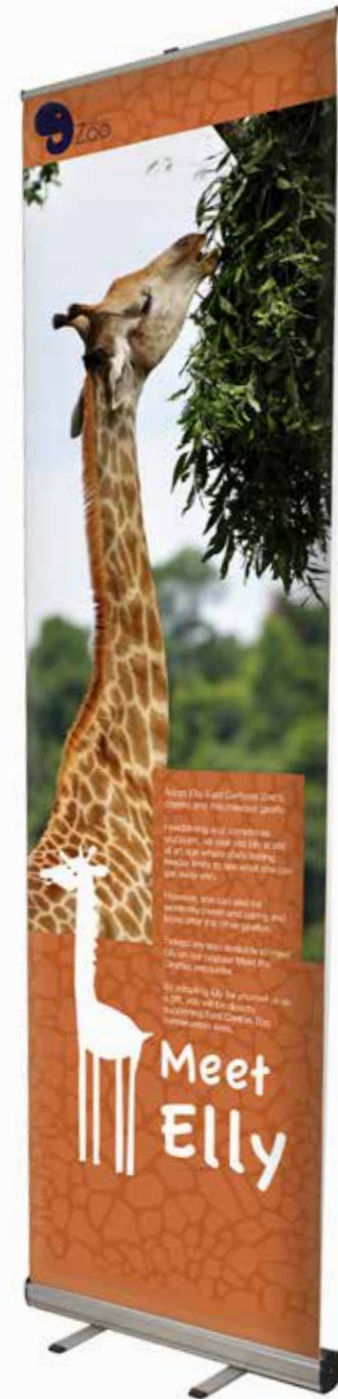

GIANT MOSQUITO think bigger



Part of our budget range, the Giant Mosquito is one of the largest economy banners you can buy. At 3m high your message will be seen by all. The hybrid pole is quick and easy to use and can be set comfortably at various heights to suit your graphics.

- This giant stand needs strong parts, special constructed telescopic poles are built for the job.



- Twin twist out feet for stability
- Part bungee, part telescopic pole
- Padded bag included
- Available in 1200, 1500 and 2000mm widths

Uno linkable banner stands



Stylish finish

Finished with a powder-coated black foot, this simple display stand supports a printed graphic panel. Ideal for companies looking for a low cost display option.

- Supplied in a carry bag and tube.
- Quick change graphic panels
- Available 80cm or 100cm wide
- Different widths can be linked together
- Overall height is 220cm (custom panels under 220cm available)



Uno is low cost portable banner stand. As standard, we supply Uno banner stands with a textured roll up banner material, graphic panel. However, for companies who are looking for a compact, lightweight option for travel abroad, we can supply Uno with a fabric graphic panel. This can be packed away into a suitcase or hand luggage, along with the pole and foot. Please note that Uno stands with fabric panels can't be linked together seamlessly.

Link your ideas

Our range of linkable banner stands are designed for clients looking for displays that are adaptable in size and can be used as single free-standing displays, to larger backdrops which can be used as high impact exhibition stands.

Lightweight fabric option



For those looking for a compact, lightweight option, we supply Uno with fabric graphic panels, making the Uno an extremely lightweight banner.

Fabrics are printed either the width of a single unit for portable banner use, or use multiple frames to create a unique lightweight seamless fabric backdrop.

Twist banner

Linkable banners



- Use as individual displays or link together
- Flexi Link panel to create any shape
- Quick and easy to set up
- No curling on edges of graphic panels
- Include small or large screens
- Stable and durable
- Curved or straight end panels available
- Low voltage spotlights
- Shelving and counters available
- Quick change graphic panels
- Compact wheeled case or carry bags
- Range of widths and heights

Twist components



Twist extras

Single Twist

- Available in 4 widths (70cm, 80cm, 90cm & 100cm)



2 Panel Twist & Linking Panel

- Available in 4 widths (70cm, 80cm, 90cm & 100cm)
- 55cm flexible linking panel
- Concave or convex

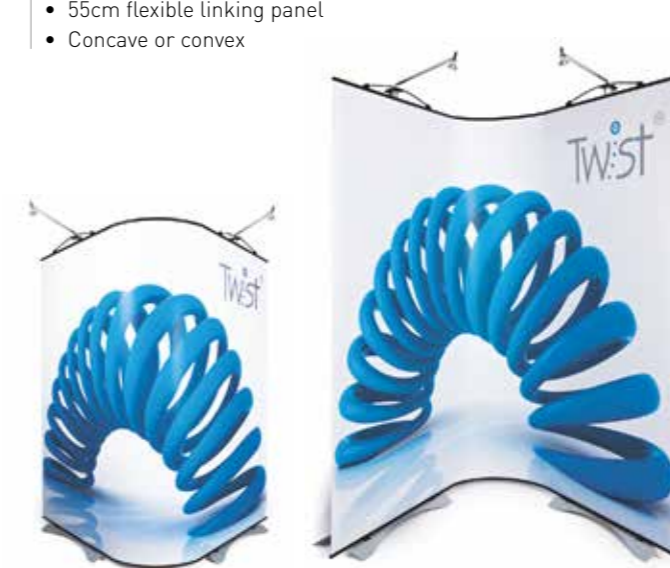

3 Panel Twist step

- Available in 4 widths (70cm, 80cm, 90cm & 100cm)



Twist Desktop



Twist desk



Twist case



ISOframe Ripple



Banner or Modular Why not both!

A truly flexible banner stand system you can use as individual banner stands which you can then link together to create a bendable display of any width. ISOframe Ripple is the perfect flexible choice for any exhibition or event.



ISOframe Ripple



You can re-use and reconfigure the size and shape of the display for future events, and with media screen attachments, spotlights and a table available as accessories its flexible enough for all your future display needs.



- Simple, tool-less assembly
- Bend and flex to suit the venue
- Compact, lightweight and very easy to transport
- Adjust the display width to suit your requirements
- All graphic panels are 800mm wide with the same fixings
- All graphic panels can be used on a frame or as a flexi-link.



Link2 seamless joined banners



durable bag for easy transport



optional halogen lights



quick-change roller graphic system

The Link² allows for unlimited banners to be seamlessly joined together to create professional, promotional and exhibition backdrops. Each Link² banner stand also has interchangeable graphic capabilities giving customers the ability to change their own graphics with no fuss - meaning that the LINK² hardware can be used indefinitely. Other advantages include a patented tension system that aids graphic alignment on uneven floors, integrated LED lighting and a flexible panel option making it ideal for shell schemes.

Elegant joins

- Link2 is the perfect system when you need a stand that can be changed to fit various events, marketing campaigns or Point of Sale adverts.
- Multiple Link² display stands can be linked together to create a straight wide backdrop.
- Or add a 23.5cm flexi link panel to create curves and wave shapes.

Interchangeable panels

- Link² has a patented and unique graphic exchange system included in the base unit. It takes less than a minute to exchange a graphic panel, and requires no expertise.
- We can send new panels to you, and these can be fitted on-site quickly and without hassle.

- Lifetime guarantee against product failure
- Premium banner stand
- Stylish base & support feet
- Premium padded carry bag
- Each system 85cm wide
- Flexi-link panel 32cm wide
- Height 2.2m

Plus roller banner



- Optional magnetic joining cap with link profile



Pole with discreet moulded top



Magnetic joining cap



Link profile (rear view)

- Unique, magnetically linkable cassette with linkable graphic hanging profile allows you to link 2,3 or more units together
- Discreet colour matched moulded magnetic joining cap
- Discreet silver anodised link profile with lockable connector bar

- Only 26mm gap between linked graphics (less than 2% of image area)
- Straightforward assembly for dramatic visual effect
- Double system graphic width: 1726mm
- Triple system graphic width: 2602mm



Spotlight - low voltage

- Low voltage - 50w
- Full pivot head



The multiple stand is the subject of pending protection under European patent application number 09178238.3

Aero linked display system



Versatile Display System

An extremely versatile display system that can be used for exhibition spaces and retail displays.

The system is modular so can be added to make larger displays at a later date.

We sell this display as a 3 panel kit or as individual retractable roller banners complete with posts with feet.

If you want to replace the graphic panels at a later date we can supply with just the graphic cassettes so you don't have to purchase all the hardware again.

The graphic panels retract into the roller mechanism for easy transportation.

The Aero banners can be joined together to make larger displays and can also be adjusted at 90 degrees to create a booth space or fit any rectangular shape.

- 5 Year Guarantee
- Height Adjustable and Available in 3 Different Widths (1m, 1.5m & 2m)
- Light & portable
- Comes with a Nylon padded carry bag for easy transport
- Fittings on top to accommodate Powerspot Halogen lights to floodlight your display.
- Choice of Graphic Panel Materials, PVC, standard roll up graphic panel material or Polyester fabric.
- Redesigned feet add stability and are more compact in transit

Vortex



- The Vortex is a very lightweight portable display system. It's lightweight design allows the user to quickly assemble the framework. The PVC graphic is easily attached for an instant professional eye catching display.
- The graphic panels are printed on tough front lit PVC which attach to the framework using brass eyelets. The PVC panels can be interchanged by the user should you wish to promote different products or services. The PVC panels are printed with colour-fast solvent inks at high resolution.
- Vortex comes complete with padded carry bag for the hardware. There is also an option of protective graphics tubes to protect the PVC panels in transit. Vortex also comes with a one year hardware guarantee.

Wedge



- The Wedge display unit is a steel base which holds rigid printed graphic panels in place. The sleek, grey powder-coated base can clamp any size printed board up to 40mm thick.
- The Wedge base is a cost effective solution to displaying floor standing foamex and MDF printed graphic panels. Ideal for venues where graphic panels can't be fixed to a wall.
- Wedge bases are available in 4 different widths; 300mm, 600mm, 800mm and 1000mm. Although the graphic panel can be wider than the base, if you require a specific width display. We recommend a maximum height of 1500mm.

Linear wave / arch



Linear Pro System

The Linear Pro System provides the looks, style and sophistication of a custom exhibit with the ease, convenience and value that you're looking for.

The Linear range of portable exhibit systems are designed to ship with minimal lead-time and are a terrific off the shelf solution for trade-shows and semi permanent displays, ideal for shopping centres and exhibition venues.

All kits accommodate optional lighting, choice of LCD screen mounts, brochure holders, product display shelves and molded carry cases.

Framing is constructed of extruded aluminium with sturdy oval steel bases. Key-Locking arms makes Linear strong, lightweight and easy to assemble.

Linear Pro 22/25/26/27

Linear Pro 26

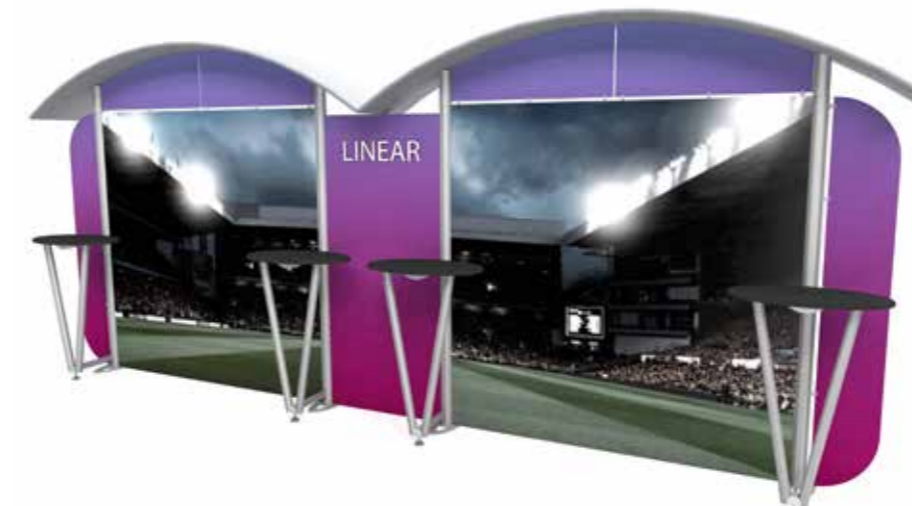

Overall assembled size (mm): 2455(h) x 6000(w) x 765mm(d)

Linear Pro 27



Overall assembled size (mm): 2455(h) x 6000(w) x 765mm(d)

Linear Arch



Overall assembled size (mm): 2475(h) x 3000(w) x 500mm(d)

Linear Wave



Overall assembled size (mm): 2475(h) x 3000(w) x 500mm(d)

Linear Pro 22



Overall assembled size (mm): 2455(h) x 3000(w) x 765mm(d)

Linear Pro 25



Overall assembled size (mm): 2455(h) x 3000(w) x 765mm(d)



- Portable with full set up instructions
- Anodised aluminium construction
- 75mm rounded modular posts
- Accessories include literature holders, LCD mount and shelves
- Additional optional accessories including spotlights, counters and carry case

Pegasus display stand



Pegasus is a low cost portable display stand. It is one of the cheapest display stands that we produce to cover a 2.5 wide area. Ideal for exhibitions and events, where a low cost, high impact display stand is required.

The Pegasus graphic panel is printed onto a one piece lightweight fabric material. The fabric graphic panel fits into a carry bag along with the hardware, to make for easy transportation. Ideal for companies where the transportation weight is an important factor in deciding which display stand to opt for. The Pegasus stand is particularly popular with companies who need to ship display stands abroad, where lower weight display stands can reduce freight costs.

Flexible Adaptable

- At its maximum size the Pegasus display stand has an overall dimension of 2540mm wide x 2515mm high. However, the framework is adjustable in size, and can be used from any size from 1429mm wide x 1000mm high.
- Please contact us for a quotation for various size options, or let us know if you have a specific size requirement, and will advise of a cost for this.

Quick Easy Set Up

- The Pegasus fabric panel display stand is very simple to set up. Simply fit the vertical poles to the base, then slide the horizontal poles through the top and bottom sleeve in the fabric graphic panel.
- Then fit the horizontal poles, and your high impact display stand is ready to use.

Cost effective fabric backdrop display

- Pegasus tension banners are available in different widths and heights to fit any size display area.
- Pegasus is very lightweight and breaks down into a small carry bag for easy transport.
- Silver powder-coated frame with telescopic adjustable poles.
- Available with fabric size 1429mm-2540mm wide and 1000mm-2515mm high.



Centro showcase

Showcase your latest ideas and products behind an attractive, secure and protected display stand. The multifunctional display can be used in tandem with the Centro range to produce stylish displays & complete modular exhibition systems. (See 'Modular' section)

- Generous individual display spaces
- Header and base panels for promotional graphic display
- Printed, white or clear shelf infill panels
- Curved 8mm thick 'green edge' acrylic shelves
- Chrome adjustable shelf brackets accept 12kg of evenly distributed products
- Featuring easy assembly connections
- Compatible with entire range
- Optional wheeled cases available



Centro display solutions

With 10 years of development the complete range of Centro frame products are incredibly strong, stylish and have come of age to provide you with a complete set of display products that can be used in conjunction with each other to produce complete Modular solutions.

Rotrlink linking system

All Centro static display products use the patented Centro Rotrlink, maintaining strength and dramatically reducing assembly time. The Centro Rotrlink twist and lock technology allows fast and easy installation.

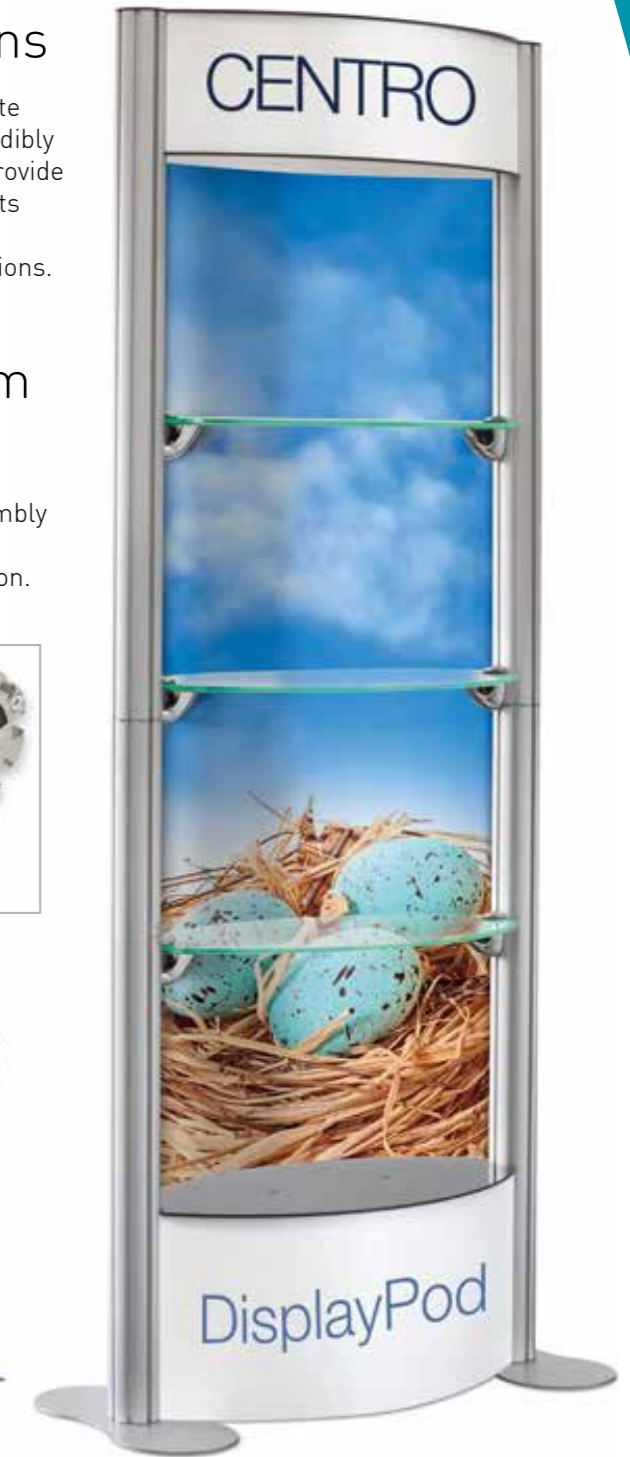

Centro-1 static display

Centro1



- Designed for a banner graphic with horizontally hemmed pockets or a rigid panel
- Innovative modular display system with contemporary neon acrylic features
- Unique, robust anodised aluminium construction
- Requiring only a single hex bit for complete assembly - 4mm hex key supplied
- Also suitable for plain/printed rigid PVC panels

- Shaped silver base plate to maximise stability, minimise footprint and ease transportation
- Overall height without lighting 2019mm
- Maximum footprint:
 - 750mm - 1006mm(w) x 380mm(d)
 - 1500mm - 1756mm(w) x 380mm(d)
 - 2250mm - 2506mm(w) x 380mm(d)
- Quality assured - 5 year guarantee

Accessories available:

- Centro podium kit
- Centro counter kit
- A4 brochure holder
- Screen mounting kit
- Choice of 50w or 150w lighting



Centro wheeled trolley case

- Compact and durable moulded plastic case and lid
- Base fitted with rubber wheels
- Moulded lid handle with additional side carry handle
- 3 lid latches with lockable facility
- White lined graphics tube 254mm dia. x 980mm can hold 4 x 1990mm drops)
- Internal elasticated product retaining strap
- Overall case dimensions 520mm(w) x 440mm(d) x 1130mm(h)
- Net weight 9.0kg
- Quality assured - 12 months guarantee

Post caps available in various colours



Range of coloured acrylic features, available in neon blue, red and green or standard frost.



Available kits shown above (dimensions stated are graphic widths).



Centro-2 static display

Centro2



- Designed for a visually seamless magnetic graphic display
- Innovative modular display system with contemporary neon acrylic features
- Unique, robust anodised aluminium construction
- Requires only a single 4mm hex key for complete assembly (key supplied with system and upgraded to power tool kit with 150cm and 225cm wide systems)

- Shaped silver base plate to maximise stability, minimise footprint and ease transportation
- Overall height without lighting 2019mm
- Maximum footprint:
 - 750mm - 1226mm(w) x 380mm(d)
 - 1500mm - 1976mm(w) x 380mm(d)
 - 2250mm - 2726mm(w) x 380mm(d)
- Quality assured - 5 year guarantee

Accessories available:

- Centro podium kit
- Centro counter kit
- A4 brochure holder
- Screen mounting kit
- Choice of 50w or 150w lighting



Centro wheeled trolley case

- Compact and durable moulded plastic case and lid
- Base fitted with rubber wheels
- Moulded lid handle with additional side carry handle
- 3 lid latches with lockable facility
- White lined graphics tube 254mm dia. x 980mm can hold 4 x 1990mm drops)
- Internal elasticated product retaining strap
- Overall case dimensions 520mm(w) x 440mm(d) x 1130mm(h)
- Net weight 9.0kg
- Quality assured - 12 months guarantee

Post caps available in various colours



Range of coloured acrylic features, available in neon blue, red and green or standard frost.

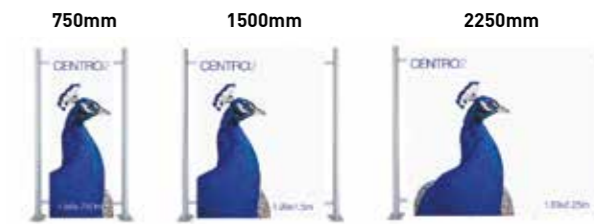

Available kits shown above (dimensions stated are graphic widths).

Without spacer bars

With spacer bars

Centro2 curved static display



- Designed for a visually seamless magnetic graphic display
- Innovative modular display system with contemporary neon acrylic features
- Unique, robust anodised aluminium construction
- Requires only a single 4mm hex key for complete assembly (key supplied with system and upgraded to power tool kit with 150cm and 225cm wide systems)

- Shaped silver base plate to maximise stability, minimise footprint and ease transportation
- Overall height without lighting 2019mm
- Maximum footprint:
 - 750mm - 1263mm(w) x 380mm(d)
 - 1500mm - 2007mm(w) x 380mm(d)
 - 2250mm - 2695mm(w) x 380mm(d)
- Quality assured - 5 year guarantee

Accessories available:

- Centro podium kit
- Centro counter kit
- A4 brochure holder
- Screen mounting kit
- Choice of 50w or 150w lighting



Centro wheeled trolley case

- Compact and durable moulded plastic case and lid
- Base fitted with rubber wheels
- Moulded lid handle with additional side carry handle
- 3 lid latches with lockable facility
- White lined graphics tube 254mm dia. x 980mm can hold 4 x 1990mm drops)
- Internal elasticated product retaining strap
- Overall case dimensions 520mm(w) x 440mm(d) x 1130mm(h)
- Net weight 9.0kg
- Quality assured - 12 months guarantee

Post caps available in various colours



Range of coloured acrylic features, available in neon blue, red and green or standard frost.



Available kits shown above (dimensions stated are graphic widths).

Without spacer bars



With spacer bars

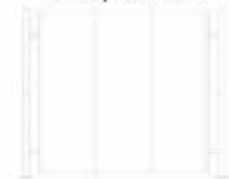

Centro3 Straight static display



- Designed for a visually seamless magnetic graphic display
- Innovative modular display system with contemporary neon acrylic features
- Unique, robust anodised aluminium construction
- Requires only a single 4mm hex key for complete assembly (key supplied with system and upgraded to power tool kit with 150cm and 225cm wide systems)

- Shaped silver base plate to maximise stability, minimise footprint and ease transportation
- Overall height without lighting 2019mm
- Maximum footprint:
 - 750mm - 1226mm(w) x 380mm(d)
 - 1500mm - 2269mm(w) x 380mm(d)
 - 2250mm - 3312mm(w) x 380mm(d)
- Quality assured - 5 year guarantee

Accessories available:

- Centro podium kit
- Centro counter kit
- A4 brochure holder
- Screen mounting kit
- Choice of 50w or 150w lighting



Centro wheeled trolley case

- Compact and durable moulded plastic case and lid
- Base fitted with rubber wheels
- Moulded lid handle with additional side carry handle
- 3 lid latches with lockable facility
- White lined graphics tube 254mm dia. x 980mm can hold 4 x 1990mm drops)
- Internal elasticated product retaining strap
- Overall case dimensions 520mm(w) x 440mm(d) x 1130mm(h)
- Net weight 9.0kg
- Quality assured - 12 months guarantee

Post caps available in various colours



Range of coloured acrylic features, available in neon blue, red and green or standard frost.



Available kits shown above (dimensions stated are graphic widths).

Without spacer bars

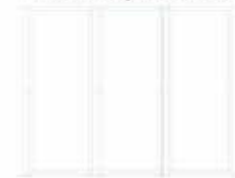

With spacer bars

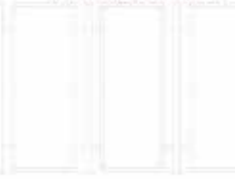

Eurostand poster display



Kit 1

- 4 x A4 Portrait double-sided 2mm thick clear acrylic poster holders



Kit 2

- 8 x A4 Portrait double-sided 2mm thick clear acrylic poster holders



Kit 3

- 5 x A4 Landscape double-sided 2mm thick clear acrylic poster holders



Kit 4

- 4 x A3 Landscape double-sided 2mm thick clear acrylic poster holders



Kit 5

- 4 x 500x700mm Portrait double-sided 2mm thick clear acrylic poster holders



Kit 6

- 6 x A4 Portrait and 6 x A5 landscape double-sided 2mm thick clear acrylic holders



With Centro free standing suspended poster display holders your images are housed securely in clear double-sided acrylic pockets, within the clean modern designed frame.

You can further add to your display by using the accessories available in the range such as literature presenters and podium tables, all available in a variety of coloured acrylics.

And not forgetting our popular iPad holders which can be fitted to either the Centro post or podium top to create a truly interactive and visually stunning display.

Eurostand poster display

Kit 4

- 4 x A3 Landscape double-sided 2mm thick clear acrylic poster holders



- Clean functional design
- Chrome connectors, stainless steel hanging wire and hex keys supplied
- Heavier profile offers stability
- Quality appearance and finish
- 1006mm (w) x 380mm (d) x 2021mm(h)

Kit 5

- 4 x 500x700mm Portrait double-sided 2mm thick clear acrylic poster holders



- Acrylic top available in neon blue, red and green or frost
- Special non-scratch, clear surface coating
- Clamps securely to Centro system post in a variety of positions
- Podium top dimensions 500(w) x 443mm(d)

Centro Accessories

As with all Centro products Eurostand can accommodate a full range of accessories.

Coloured end caps, brochure holders and work surfaces available.



Screen mounting kit

- Expanding bracket clamp with heavy-duty screws to secure screen to post
- Easy assembly with hex key
- Screen size upto 22"

iPad holder

- Secure locked housing
- Quality appearance and finish
- Available in textured black or white finish
- Holder rotates 360°



Brochure holder

- Colour co-ordinated acrylic A4 portrait brochure holder
- Available in neon blue, green, red, or standard frost
- One piece acrylic for strength
- Simple 'hook over' style fitting

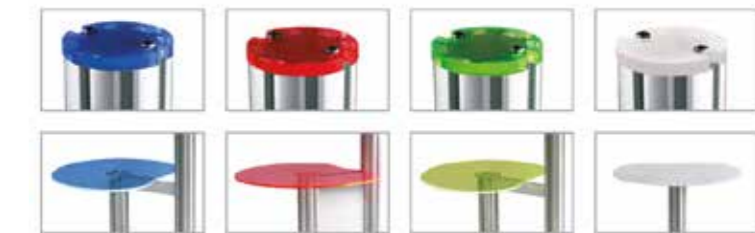

iPad displays

Budget £

Mid Range £

Premium £

Launchpad tablet display

Elegant & portable, the Launchpad tablet stand is an ideal floor standing display that can house both iPad and Samsung tablets. Its rotating head allows for portrait or landscape viewing and is a great option in retail, showroom, office, event or restaurant environments.

Launchpad is continually powered through a discrete internal cable management system and supplied 2m USB cable



£

Budget iPad display stand



£

Budget is our low cost floorstanding unit. This sleek and portable iPad display unit can be used with all iPad tablets excluding iPad 1. The iPad housing can be positioned portrait or landscape, and is made of steel.

Secure housing comes with security screws, and an Allen key, for extra security the base can be bolted to the floor. This iPad display stand is a theft resistant unit, ideal for events, exhibitions and reception areas.

Budget iPad Display stand is available in black, silver or white.

Techno Space customised ipad stands



£

Techno Space and Techno Space Plus Deluxe - stylish, light and cost effective iPad stand. Can be used as a low cost freestanding iPad display with the option to add a rollable graphic panel or a custom shape ridged graphic on the Deluxe model.

The steel cradle has a secure lock and offers 360 degree rotation, plus tilt and swivel features and is designed to hold you iPad and a portable power pack.

Techno Space Deluxe has optional graphic fixing kit to mount custom shaped rigid graphics to the vertical post, with quick and easy thumbscrew style assembly in only a few seconds allowing you to change to any other shape in the future.

With portability as well as security the Techno Space offers the perfect solution for interactive presentations on the go.



iPad displays

Podium iPad display stand



£

- Single post, base and acrylic podium table with versatile iPad holder
- Continuous iPad power supply when connected to UK mains
- Table height 1014mm
- USB charging cable concealed within enclosure behind iPad before exiting through centre hole
- USB cable passes through holder support head, then down column tube
- USB cable connects to adaptor which in turn connects to figure 8 power lead
- 3m figure 8 power lead and UK 3 pin plug exit stand for connection to appropriate power supply

iPad Kiosk & iPad Kiosk Plus



£

iPad Kiosk - Floor standing iPad display units with a choice of a curved or straight upright frame. This is a stunning iPad display solution that can have either a black or white acrylic infill in the upright section, or a graphic panel infill which offers an ideal opportunity for branding to ensure maximum impact.

The bezel surround comes in a choice of black or white acrylic and shapes, or we can produce a printed adhesive panel fitted to the bezel.

iPad Kiosk Plus - iPad Kiosk Plus is intended for high traffic public use and has an incredibly secure enclosure, perfect for busy environments including point of sale kiosks and digital concierge, can be Bolted to the Floor for Greater Security.

Curve iPad display stand



£

The Curve iPad Display Stand is a premium quality free standing unit designed for quick and easy utilisation where power may not be available.

- Durable silver grey painted steel enclosure and matching base
- Black high gloss acrylic fascia
- Push button security lock with key release
- Versatile enclosure over tilts through 120° and fully rotates 360°
- Holds iPad 2, 3 and 4
- Home button recess allowing Guided Access on iOS 6 and above

iPad displays



Counter iPad display stand



Counter Movement

Our Counter Mount iPad display unit, can be fitted to most standard surface that can be drilled to fit the screw fixings. This mount can be used in conjunction with many of our portable counters. If purchased with one of our counters, we will pre-drill the holes for you, to make for simple set up.

Power cables can be run through the support arm of this stand.



Slimline iPad wall mount



The Slimline range of iPad tablet enclosures provide a sleek wall mounted display, which has an intuitive design allowing it to fit flush to any wall surface. This enables any cables or power leads to sit within a recess within the wall, creating a seamless and streamlined appearance. The unit also includes an optional conduit for customers who wish to conceal any cables on the wall exterior.

Four available models cover a large range of tablet size and compatibility options. Cover plates that hide or reveal home buttons and cameras give you more control and allow you to have the exact interface you need for your display.

Product Features:

- Rugged Secure security
- Secure and lockable
- Hidden cables
- Continuous power charging
- Made from ABS, acrylic, aluminium and durable steel
- VESA compatible interface plates available
- Landscape or Portrait orientation



- Available with a white or black bezel in five shapes - square, rectangular, circular, cloud or speech bubble.

Wall Mount iPad display stand



Our wall mounted tablet enclosures can be secured to any wall surface using a standard VESA mount. A cost effective and versatile tablet display solution for any showroom, reception, or public space. Available with black or white acrylic surround, with five different bezel shapes.

Our Wall Mounted iPad Display stands come with two fixing options:

- Fixed - fits flat to the wall.
- Tilt - tilts, and rotates 180 degrees.

Product Features:

- Supports iPad 2, 3 and 4 as standard
- Secure and lockable
- Rotates 180° (view tablet in landscape or portrait)
- Hidden cables
- Continuous power charging
- Concealed or revealed 'Home' button
- Black or white acrylic bezel

iPad displays

Poseur 1 iPad display stand

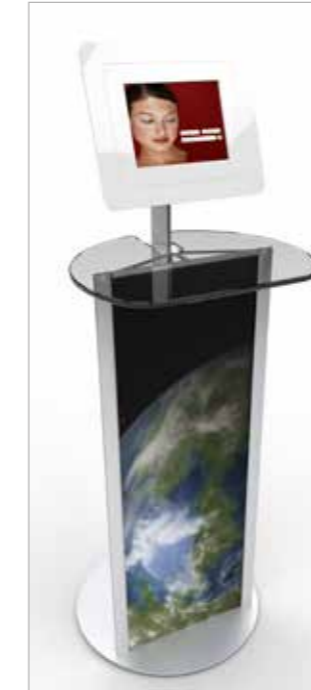

This unit has the option to be supplied with a branded graphic panel that we produce in-house.

- The quick and simple self assembly constructions makes this iPad display unit suitable for either short term events just as exhibitions, or for more permanent display.
- This unit features a clear 'glass look' acrylic shelf and can be used for displaying brochures, business cards and other marketing materials. Or the ideal place to position other peripheral devices. The iPad tablet is securely mounted in the enclosure.
- Power cables can be run inside, continual power supply.
- The Poseur Table 1 can be ordered with a choice of black or white bezel colour, and with a choice of bezel shapes.

Poseur 2 iPad display stand



This unit comes with three mounts ensuring that it can be used for multiple customer interaction.

- The quick and simple self assembly constructions makes this iPad display unit suitable for either short term events just as exhibitions, or for more permanent display.
- This unit features a clear 'glass look' acrylic shelf and can be used for displaying brochures, business cards and other marketing materials. Or the ideal place to position other peripheral devices.
- The iPad tablets are securely mounted in their enclosure.
- Power cables can be run inside, continual power supply.
- The Poser Table 2 can be ordered with a choice of black or white bezel colour, and with a choice of bezel shapes.

iPad Duo / Quad display stand



Ideal for retail, events, showrooms and offices. Fully transportable and takes up minimal storage space when not in use. Both Duo & Quad are designed to command attention and fit in with all modern retail & reception situations.

- Single post, base and cross shaped support arm with 2x or 4x versatile iPad holders.
- Available in textured black or white finish.
- Continuous iPad power supply when connected to UK mains.
- Heavy duty steel base finished silver with rubber foot pads.
- Optional molded wheeled trolley case.

iPad displays

Design iPad Holder Post



Simple, stylish and sturdy iPad display. The Designer iPad Holder Post incorporates the versatility of the Linear system with a secure iPad holder.

Features and Benefits

- Available in black, white or silver
- Features a 360° mount
- Secure housing unit
- Available for all iPads except mini
- Optional shelf and literature holder accessories

Formulate iPad stand



Lightweight and strong, the Formulate iPad Stand is a practical alternative to heavier iPad stands. Incredibly functional and adaptable, the mounting system is fully rotatable allowing the iPad to be orientated both landscape and portrait.

Features and Benefits

- Single or double sided fabric print
- Quick and simple to assemble
- Create stunning fabric graphics
- Ideal permanent feature or portable display
- Attractive alternative in any retail environment

Towers

Screen Tower & Screen Holder



Screen Tower - Commanding individual screen puts your presentation into the heart of the action. Screen Tower is built for the job of delivering your message wherever you need it. Added printed branding helps your audience with a further targeted message or display.

- Fits 42" to 72" LCD or plasma monitors (less than 36kg)
- Adjustable bracket displays screen at horizontal or vertical aspect
- Poster display protected with non-glare screen

Screen Holder - Quick build and solid construction make this a secure option to display your literature and feature presentation.

- Stand fits 32" - 72" LCD or plasma TV, Suitable for VESA 200x200
- Optional height adjustable brochure tray and shelf available

Illuminated Totem



- Double-sided freestanding poster display
- Elegant convex design
- Front-opening snapframe sides
- Anti-glare poster covers
- Fluorescent tube lighting (single or double depending on size)

Light Tower



- Light control - on/off switch built into Tower
- Optimal light dispersion
- Install in just one minute
- Padded bag with zipper
- Single sided graphics

Sign Holder 1



- Change between portrait and landscape
- A3 or A4 sizes
- Stylish internal poster display
- Front-opening snapframes for quick poster change
- Round corners
- Anti-glare cover
- Polystyrene base with hidden steel plate for optimum stability
- Silver anodised aluminium leg (50mm x 25mm oval)

Sign Holder 2



- Easily adjustable height
- Change between portrait and landscape
- A3 or A4 sizes
- Display angle adjustable
- Front-opening snapframes for quick poster change
- Adjustments by hand
- Soft round corners
- Anti-glare cover
- Base features hidden steel plate for optimum stability
- We can supply the unit only, or with the printed poster fitted.
- Optional wheeled feet are available.

Towers



Lumos backlit display stands



- Internally illuminated with white LED strip lighting
- Wired or battery options available
- Available in four sizes
- Mini Tower - 953mm high, 315mm
- Midi Tower - 1318mm high, 315mm
- Maxi Tower - 2178mm high, 315mm
- Double Tower - 1318mm high, 512mm wide, 315mm deep
- Sleek and elegantly designed matt white base, provides added stability.
- Two part upright hardware ensures everything packs away into a standard sizes graphic bag.

Attractive from every angle

Ideal partner to our banner stands, podiums, backdrops & fabric display stands

Our portable Towers are designed to deliver your brand with 360° visibility, making it easy to get noticed wherever used. Strong and sturdy stance commands attention.

They looks great from top to bottom, side to side & quickly becomes the focus of attention.

We use the same high impact, premium graphic panels that are used throughout our range.

Can be supplied with the framework in a carry box with graphic panels in a carry drum, or the complete system and panels can be supplied in a heavy duty wheeled case.

Set up in minutes and pack down just as fast. Simply open the frame, lock them into place and magnetise your panels onto the frame.

Linear Column

- Linear Columns are free-standing double sided display stands, which come as a graphic display, or with the option for internal lighting.
- The lighting option can be white or RGB lighting for added back lighting effect.
- Comes in two sizes - slim and standard.
- Slim - 1010 (h) x 380 (w) x 245 (d) mm
- Standard - 1010 (h) x 640 (w) x 325 (d) mm
- Both are available with an option for an iPad display stand to be fitted to the column, and side mounted A4 brochure holders on the side profiles.
- The frame is a satin anodised aluminium frame which is both strong and lightweight and simply clips together. The top and base are made from MDF and are finished in either Birch, Black, White or Silver.
- The display flat-packs and can be assembled within 10minutes.



Towers

Pop Up Quick tower



- 64cm diam x 225cm high
- 10kg weight
- Quick and easy setup
- Quick change graphic panels
- Lighting available
- Carry bag

Linear Graphic & Literature Post



- Free-standing Graphic and Literature Display
- The Graphic & Literature Post is a unique display unit, great for promoting your brand and for displaying literature.
- Supplied as standard with 3 x literature shelves and a graphic panel which can be shaped to suit your needs.
- We print the graphic in-house and mount it to 5mm Foamex which clips to the display post.
- As standard the display comes with a 6kg weighted foot to offer the display stability, however an additional weight can be added for extra stability.

Info Board



- Freestanding poster display
- Displays an A1 poster which is securely housed within a front opening snap frame.
- Comes with an anti glare PET poster cover.
- We can supply the unit only, or with the printed poster fitted.
- Optional wheeled feet are available.
- Single sided, or double sided display (with two snap frames).
- Can be supplied with an acrylic brochure shelf.
- Option for internal lighting within the snap frame. We can supply printed posters that are printed onto back lit material.

Literature stands

Zed Up



- 151cm high x 48cm wide x 36.5cm deep (8.5kg)
- Folds down for easy transportation
- 6 pockets A4 capacity
- Can fold down with literature still in place
- Available in silver
- Padded carry bag included

Zed Plus



- A3 brochure - overall dimension 142cm high x 47cm wide x 37cm deep (11kg)
- A4 brochure - overall dimension 146cm high x 25.6cm wide x 37cm deep (7.5kg)
- A5 brochure - overall dimension 130cm high x 19.4cm wide x 28.4cm deep (6kg)
- 6 Double-sided acrylic shelves (7 for A5 option)
- Available in anodised silver
- Heavy duty hard case for safe transportation

Aura



- 140cm high x 34cm wide x 31cm deep
- One step easy cantilever assembly action
- A4 portrait format
- 4 pockets
- Available in silver finish
- Padded carry bag included
- Anti-collapsible locking arm
- Birch thermo formed base

Cascade



- 148cm high x 26.5cm wide x 31cm deep (5.5kg)
- Automatically locks in open or folded position
- 4 pocket A4 capacity
- Robust transparent polycarbonate pockets
- Premium carry bag

Media4 Deluxe



- Modern and stylish literature stand with a chrome base.
- Durable and robust, so ideal for regular use.
- Collapsible portrait literature holder which has strong pockets.
- 152cm high x 26cm wide x 28cm deep

Linear Audio-visual Literature Post



- Includes an LCD screen fitting
- Six A4 sloping shelving for literature display.
- Extremely portable and easy to set up.
- Robust and will withstand a lot of usage.
- Comes with 6 x fully adjustable shelves
- Each brochure shelf can be individually angled.
- 186cm high x 59.5cm wide x 45cm deep

Brochure Display 1



- 130cm high x 25cm wide (1.2kg)
- Quick and easy set up
- Our lightest brochure stands
- Suitable for A4 or A5
- Easy to transport

Literature stands

ST Literature



- Latest in stylish literature stands
- Build in seconds
- Bright chrome finish
- Perfect for receptions
- Robust for long term use
- Compact and portable
- Supplied with heavy-duty padded carry bag

Totem



- Silver aluminum side rails with a silver or black powder coated central panel
- Hold up to 8 metal brochure shelves or 8 injection molded leaflet pockets
- Shelves and pockets simply slot in all A4 brochures to be viewed face on
- Easy to assemble with screw fix metal base plate
- Injection molded DL clear pockets also available to order

Vertex



- Clean functional design
- Solid stand features six A4 portrait acrylic shelves
- Heavier profile offers stability
- Quality appearance and finish

Tabletop stands



Twist Desktop

- Mini display for tight space situations
- Extra impact to complement your main Twist display
- Extremely portable and cost effective
- Twist banner style and quality that you know and trust
- Illuminate up your message with optional light



Formulate

- Innovative & portable display
- Compact and lightweight
- Stylish design
- 157.5cm(w) x 114cm(h) x 36.5cm(d) - 3.43kg
- Single or double sided
- Easy set up

Mini Quick

- Attractive tabletop display
- Ideal when space is limited
- Compact, lightweight and easy to assemble.
- 146.6cm(w) x 121.9cm(h) x 29.8cm(d) - 10kg
- A mini version of our larger Impact pop up stands.
- Ideal partner for one of our printed tablecloths



Breeze

- Lightweight aluminium construction
- Ideal for desktop placement
- Stylish design
- A4 210mm(w) x 297mm(h) - 0.35kg
- A3 297mm(w) x 420mm(h) - 0.45kg
- Easy set up

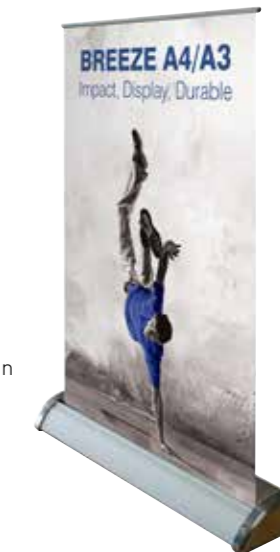



Shell Clad graphic panels

Think outside the box

We can help you transform a shell scheme from a boring exhibition area to a high impact brand promotion area with quality shell clad panels.

The reality of shell schemes are row upon row of sales cubicles, all looking more or less the same.

Stand out from the crowd with the single most important function of your stand - IMPACT.

With Shell-Clad fittings we can produce graphic panels that fit to a shell scheme wall to create large graphic displays.

Shell-Clad is designed to make money rather than save money and it is the right solution for those that are serious about exhibition marketing.

It is a bridge between standard shell scheme booths and purpose designed stands.

More expensive than the common place pop-ups but a fraction of the cost of a bespoke build.



Mounted wall frames

Mounted canvas frames & wall lightboxes have developed leaps and bounds from traditional stretched canvas prints. We now offer a full range of off the shelf options and built to order sizes, frames that have effective and dynamic finishing styles and back lit options.



Easy to change graphics with the minimum of fuss, your own staff can fit or change graphics quickly and easily, even during opening hours, with no training or tools required. The system extends into illuminated and non-illuminated, single and double-sided, wall-mounted and freestanding along with columns, cubes and full lightwalls.

Flexible ink technology allows us to produce beautifully detailed graphics - right down to the smallest text, finest hairs and subtlest of skin tones - not possible using other print processes.



Stretch Freestanding fabric display

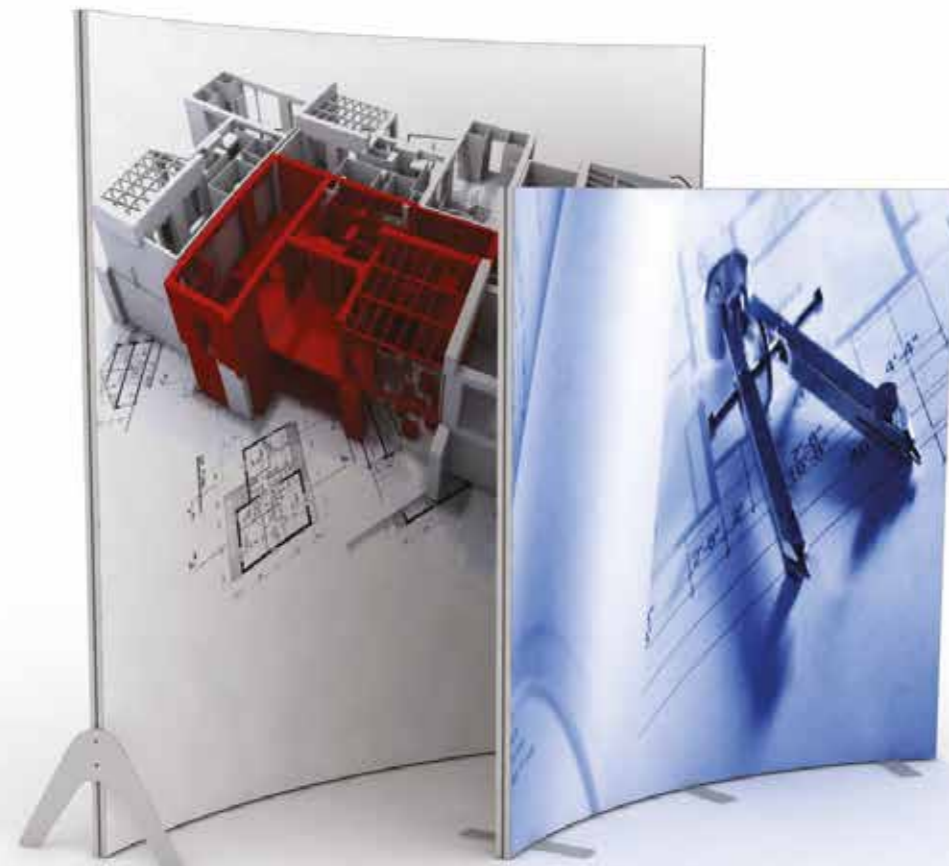

Straight/Curved End Foot



Stretch Wave Foot

Protective case



Stretch freestanding display stands are designed for companies looking for professional exhibition and events backdrops. All Stretch products are available with easy to fit fabric graphic panels which are supplied with silicone edge strips which slide into the framework. Available with a straight or curved frame including a single or double sided printed fabric panel.

- Premium aluminium frame
- Quick change fabric panels
- Range of widths from 1m to 4m
- 2m or 2.5m high
- Available curved, straight or wave frame
- LED backlighting available
- Supplied with wheeled case

Stretch Freestanding fabric display

Stretch Straight

- Available in 4 widths (100cm, 200cm, 300cm & 400cm). Available 2m or 2.5m high



Stretch Curve

- Available in 4 widths (100cm, 200cm, 300cm & 400cm). Available 2m or 2.5m high



Stretch Wave

- Available in 3 widths (100cm, 200cm & 300cm). Available 2m high



Stretch Straight Backlit

- Available in 4 widths (100cm, 200cm, 300cm & 400cm). Available 2m high

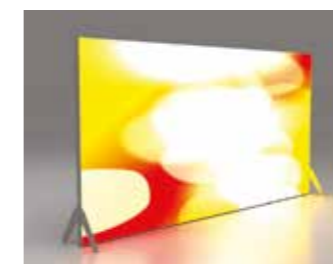

Stretch Straight Bespoke

- Available in 4 widths (100cm, 200cm, 300cm & 400cm). Available 2m high



Stretch curved fabric displays

Stretch Pod



Our Stretch Pod display stands are designed for companies looking to create a unique curved enclosed meeting area at events or venues where a degree of seclusion is required. All of our Stretch products are available with easy to fit fabric graphic panels which are supplied with silicone edge strips which slide into the framework. Stretch Pods can be created with a fully digital single or double sided fabric graphic panel. Panels can easily be interchanged enabling a Stretch Pod to be adaptable to different branding.

Stretch Arch



Our Stretch Arch structures are unique displays designed for companies looking to create an eye catching display structure at an event or venue. Stretch Arch can be used as a permanent or temporary structure with an arch height of 2m. All of our Stretch products are available with easy to fit fabric graphic panels which are supplied with silicone edge strips which slide into the framework. Stretch Arch can be created with a fully digital single or double sided fabric graphic panel. Panels can easily be interchanged enabling a Stretch Arch to be adaptable to different branding. Stretch Arch is a cost effective method of creating a truly unique display. Ideal for space only exhibition sites, at a fraction of the cost of traditional bespoke displays.

Verso fabric stands



With Verso fabric walls you can make a great impact with a backwall at your own required size, shape and height. Update the size and ad new graphics with a fully adjustable frame. The frame is easy to build and the fabric is attached at working height before being lifted.

- Build up-to 18m square walls with one system
- Adjustable frame - Create bespoke shapes and heights
- Easy tool free setup
- Straight or curved profiles





Impact fabric



Impact Fabric stands are now available in four sizes up-to 4m wide. In less than a minute you can set up a graphic backdrop with a huge display area. Low maintenance and light fabric offers a perfect alternative to paper based stands.

The fabric graphic panel is fixed to the frame with a strong industrial Velcro fitting, even when the display is stored away in the carry bag. The frame locks together with magnetic fixings, which hold the graphic panel tight to the frame.

Impact Fabric pop-up stands come in a durable padded trolley bag on wheels, which makes transportation a breeze. There is no need for separate magnetic bars, (which are essential for standard pop up displays) which keeps weight to a minimum. The perfect high impact display stand for those looking for lightweight, easy to use exhibition stands.

Embrace linkable fabric stands



Embrace 4x3

Purpose made SEG textile graphics hug the frame to create a sharp, effective back wall. Use a stand-alone frame or take advantage of the systems flexibility by joining multiple frames together to create a straight wall or a seamless 90 degree corner.

Embrace offers a quick build, easy care, minimal effort venue solution.

- Available in four versatile size options
- Linkable – createdvenue filling structures
- Easy tool free setup
- Mounted lights available
- Easy fit SEG (Silicon edge graphics)

Embrace 3x3



Embrace 1x3



Embrace 2x3

Formulate system

Aluminium frame with tensioned fabric graphics

Formulate is a new and innovative type of exhibition and display stand, ideal for companies looking for a unique display option.

The aluminium framework clicks together, and then a printed fabric panel fits snugly around the frame.

The fabric graphic panel can be printed either single or double sided.

We produce the Formulate in wide range of shapes. Used as banners, back walls, table-top stands and complete systems that create amazing 3D effect stands.



Create a 3D effect

- Formulate has three optional additions that can be used to create a 3D effect.
- These include an angled, curved ladder and trapezium column which fits to the front of the frame.
- These will enable any exhibitor to have a unique display stand which will help you to stand out from the crowd.

Ultimate in portability

- The aluminium tube framework, and fabric panel makes this display stand compact and lightweight.
- A 2900mm wide display weighs under 9kg, making this one of our lightest weight backdrop options.
- The framework clicks together, and is supplied with a numbering system, to make set up very quick and easy.
- A 2900mm wide display can be set up in 15 minutes.

Formulate fabric banner stands

Monolith Banner



The Monolith narrow banner is the slimmest model in the Formulate straight range, its narrow profile allows it to be used as a fabric banner rather than a back drop wall. Ideal when you want the traditional banner look but need the form and functionality of the Formulate system.

Curl Banner



Beautifully curved, the Formulate Curl is a seductive alternative to traditional banners. The gentle oscillation imitates the curves found on the Formulate Serpentine and Formulate Serpentine Slope, making them ideal counterparts to the Formulate Curl. Lightweight and portable, the Curl is easy to assemble and disassemble and comes complete with its own fabric carry bag.

Slant Banner



The Formulate Slant is our latest fabric banner similar to the popular horizontal curve wall, its slim profile allows it to have the look of a curved banner combined with the benefits and form of a fabric system.

Easy to assemble frame combined with a double-sided fabric graphic that simply slides over the structure to create this visually pleasing shape.

Snake Banner



This modern ultra stylish fabric display is large and commanding. Stretch fabric material fits the tubular frame like a sock. With strong banding and a stylish concept you're bound to draw attention and admirers.

Formulate straight fabric stands

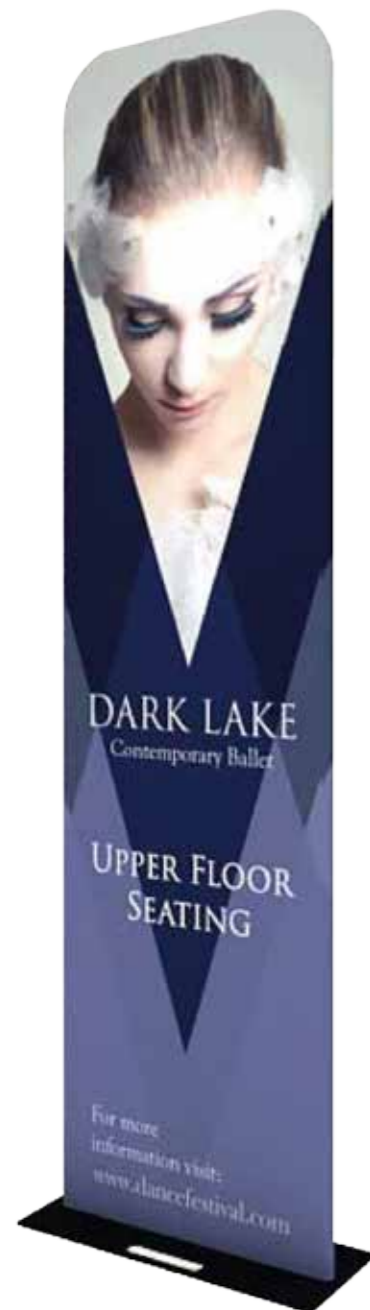

Stand Alone straight walls

Formulate now comprises of a range of individually supplied walls that offer an attractive alternative to traditional banners and pop-up displays. The straight walls are available with sturdy metallic feet or strong metal base option found in the Monolith model. If you need something more dynamic and even more eye-catching, consider the Formulate curved models.

All formulate systems are made from a strong metallic frame that's light and easy to assemble. The graphics are hard wearing and can be easily folded away when transported or stored.



Formulate Straight

Makes an ideal back or dividing wall, ensuring a dynamic and attractive exhibition spaces, an incredibly portable exhibition companion.

Width	Height	Depth	Weight
2.4m	2.3m	0.5m	6kg
3m	2.3m	0.5m	7.5kg
6m	2.3m	0.5m	11kg



Formulate Straight Slope

Tapering gently from left to right (or vice versa depending on your design) adds an angular dimension to a display or stand.

Width	Height	Depth	Weight
3m	1.8m-2.3m	0.5m	7.5kg
6m	1.8m-2.3m	0.5m	10kg



Formulate Monolith

Tall and imposing with a heavy metal base. Great alternative to roller banners.

Width	Height	Depth	Weight
0.65m	2.3m	0.25m	12kg
0.95m	2.3m	0.25m	15kg
1.2m	2.3m	0.25m	20kg
1.5m	2.3 mm	0.25m	24kg



Formulate Serpentine

With a wave like shape it creates a subtle backdrop that's easy on the eye. Strong frame and Formulate reliability.

Width	Height	Depth	Weight
2.4m	2.3m	0.4m	5kg
3m	2.3m	0.4m	6kg
6m	2.3m	0.6m	8kg



Formulate Curved Slope

Tapers down gently from one side to the other with a mildly sweeping curve. Creates the ideal dividing wall with a unique organic form.

Width	Height	Depth	Weight
3m	1.8m-2.3m	0.5m	5kg
6m	1.8m-2.3m	0.7m	10kg



Formulate Serpentine Slope

Undulating fabric curves Serpentine slope creates a stunning back wall or dividing wall, gentle slope to display fabric graphics.

Width	Height	Depth	Weight
3m	1.8m-2.3m	0.4m	6kg
6m	1.8m-2.3m	0.8m	10kg



Formulate Curved

With its playful shape and ease of use, it offers an inspiring alternative to a straight fabric display.

Width	Height	Depth	Weight
2.4m	2.3m	0.4m	4.75kg
3m	2.3m	0.5m	5.25kg
6m	2.3m	0.7m	7.5kg

Formulate curved fabric stands

- Quick and simple to assemble
- Manufactured from strong 32mm aluminium tube
- Components labelled with matching symbols for easy assembly
- Packs away into a fabric carry bag
- Easy care washable graphic
- Tool free assembly
- Easy fit graphic with zip fastening



Formulate Vertical Curve

Concave and resting back on two aluminium legs, this display stand offers stability and strong brand delivery with its shield like form.

Width	Height	Depth	Weight
3m	2.3m	0.6m	9kg
6m	2.3m	0.6m	16kg



Formulate Arches

Make your entrance with the Formulate range of fabric arches, three amazing configurations to really make your mark at any even or retail space.

Made with the same 32mm aluminium tube frame found through the Formulate range, which is incredibly light and easy to construct. Simply build the frame and slip over the extra durable, stretchy graphics to create the stand.



Formulate Arch 2.7m

The smallest in the family but by no means the least impressive.

Sturdy wide base and fabric valance, the 2.7m Arch has ample space for innovative artwork.

Width	Height	Depth	Weight
2.7m	2.3m	1m	12kg

Formulate Arch 6m

The 6m Arch is the ideal structure to use in large retail spaces and exhibition events.

With a total height of around 4m and a huge 6m surface to print on you'll make a impressive mark on any space.

Width	Height	Depth	Weight
6m	4m	1m	25kg



Formulate Arch 6m - Triple

Comprising of three 6m wide arches joined in a unique rib configuration, this is an exhibition stand which is aesthetically pleasing, quick to build and never forgotten in a hurry!

Width	Height	Depth	Weight
6m	4m	5m	82kg



Formulate hanging banners

With seven very different shapes for any situation you will always dominate air space from afar.

Formulate Hanging Banners are now available in a multiple range of sizes and shapes, you won't fail to command attention or add even more impact to your brand.

- Tool free assembly
- Shapes available in a variety of different sizes
- Easy fit double sided graphic socks with zip fastening
- Supplied with hanging loops to suspend from ceiling



Circle



Square



Rectangle



Triplet



Triangle



Tapered



Eye

Foam Cube



Our custom cube beanbags are printed on high-quality waterproof polyester fabric. Printed using dye-sublimation transfer, which means you can have any colour, or printed design imaginable, giving you sharp images and vibrant colours.

- Different weights and finishes for multiple uses
- Make a comfortable branded seats with hard filling option



Formulate fabric counters



Light, seamless podiums

Building on the successful Formulate range of strong, light fabric display systems, we now supply fabric counters that can compliment the range to complete the look.

With seamless graphics that are both light and washable, combined with a five-year guarantee, your counter will create outstanding first impressions for years to come.



Oval formulate counter

With shelving (6mm frosted acrylic):

Width	Height	Depth	Weight
0.6m	2m	0.4m	14kg

(Maximum load: 50kg evenly distributed)

Without shelving:

Width	Height	Depth	Weight
0.6m	1m	0.4m	9kg

Shapes and options to suit

Three shapes for a distinctive look, Oval Counters are ideal for reception points at events or product promotional stands, supporting an optional top external shelf system that's strong and stylish.

Alternatively the more traditional Rectangle Counter, available in two widths, provides commanding reception point, all models accommodate optional internal acrylic shelving.



Rectangle formulate counter

Width	Height	Depth	Weight
0.8m	1m	0.5m	16kg

(Maximum load: 50kg evenly distributed)



Large Rectangle formulate counter

Width	Height	Depth	Weight
1.9m	1m	0.5m	30kg

(Maximum load: 50kg evenly distributed)



Solus promo counter

A presentation point or graphic tower, joining components are molded from clear materials so as not to interfere with the graphic effect.

Units	Width	Height	Depth	Weight
1	0.8m	0.9m	0.4m	8kg
2	0.8m	0.9m	0.4m	8kg
3	0.8m	0.9m	0.4m	8kg



Optional Swift iPad counter top



Swift 360 promo counter

Graphics look great from all angles. Choice of two heights, strong enough to take large weight loads, you can showcase a variety of products in all shapes and sizes.

Model	Height	Depth	Weight
Standard:	0.9m	0.5m	4.5kg
Small:	0.5m	0.5m	4kg

Promotional counters

Retail Counters offer a different option to standard podiums, designed specifically to be visible from afar, with product storage & graphic display options

Strong yet light, made from durable PVC with bright interchangeable graphics.

Idea for promotions at shopping centres, supermarkets and trade-shows.

Finesse promo counter

The Finesse promotional display, the latest in compact promotional counter design. A light, portable unit that packs away neatly and can be built in under two minutes!

Width	Height	Depth	Weight
1.2m	0.9m	0.4m	12kg



Demo Center promo counter

High quality, lightweight, re-usable, easy to assemble polypropylene body panel with rounded front. Incorporating unique hinges for easy folding, transportation & setup.

Width	Height	Depth	Weight
0.8m	2.2m*	0.5m	10kg

*Counter height: 0.9m



Grafix promo counter

Added benefits of the Grafix counter include a interchangeable fixing system for front graphics, allowing product promotional changes in an instant.

Width	Height	Depth	Weight
0.8m	2.2m*	0.5m	12kg

*Counter height: 0.9m

Podiums

Pop up counter

- 138.5cm wide x 90.3cm high x 53.5cm depth



Mini pop up counter

- 85cm wide x 103.5cm high x 36.5cm depth



Lumos counter

- 51.2cm wide x 95.3cm high x 31.5cm depth
- LED internal lighting as standard



SD01 counter

- 115cm wide x 88cm high x 50cm depth
- Graphic wrap available



Podiums

Atlas

- Atlas cases can be joined together with the Atlas Linking Kit to create versatile counter shapes.
- Affordable storage and counter units combined.
- Tough, durable and adaptable



Zeus

- Podium & optional iPad counter
- Store and transport pop-up display stands
- Supplied with a tabletop, and a printed graphic panel that wraps around the case
- Tabletops are available in white, black or silver



Zodiac counter

- Available in eleven different sizes, (see website)
- Robust counter designed for long term use.



V-Counter

- 95cm wide x 102.5cm high x 52cm depth
- iPad option



Lectern stand

- Branded conference presentation
- Printed acrylic or foamex graphics
- optional microphone & shelf



* Wooden tops discontinued



Oyster case counter

- Counter size when open 143cm wide x 102cm high x 59.5cm depth



Podium Pro

- 91cm wide x 93cm high x 48cm depth
- Graphic wrap available



Round Plinth

- Single or nested plinths
- Tops available in Birch, Black, Silver or White
- Printed or coloured foam backed loop nylon wraps
- Various sizes. Hard and soft bag options



2017 Outdoor collection

Mobile Advertising - Sail Banners - Branded Outdoor Shelters



 miragedisplay.co.uk

Sail banners

Teardrop



- Available in four sizes, range of heights 2.4m to 5.6m
- UV resistant inks
- Washable & colour-fast
- Available single or double sided (each side can have different images)
- Easy set up

Windchaser



- Available in four sizes, range of heights 2.5m to 5.5m
- Weather treated fabrics
- UV resistant inks
- Washable & colour-fast
- Available double sided and single sided
- Easy set up
- Rotating ground fitting

Feather banner



- Available in four sizes, range of heights 2.1m to 4.8m
- Available single or double sided
- UV resistant inks
- Washable & colour-fast
- Superior rotating stake with ball bearings
- Easy set up

Flagstand XL



- Up to 5.5m high
- Single sided fabric
- Choice of feet supports
- Simple Construction
- Replacement fabric panels available

Pop Up A-Frames

Pop Out Banner

- Available in six widths (1.2m, 1.4m, 1.7m, 2m, 2.6m & 2.75m)



Rectangular Pop Out Banner

- Available in four widths (1.4m, 2m, 2.6m & 3m)



Circular A-Frame

- Available in three diameters (0.7m, 1.2m & 1.5m)



Vertical A-Frame

- **Round Bottom**
0.7m W x 1.2m H
1m W x 1.2m H
- **Flat Bottom**
1m W x 1.5m H
1m W x 2m H



Outdoor shelter

Zoom Tent

There's plenty of room to shelter from the elements underneath the Zoom Tent, available in four sizes. The polyester canopy offers extra protection from the weather with the sturdy Zoom Tent frame.

Save time and money with our budget canopy, options to customise, make it your own. Now available in the four sizes.



- Print your message and brand across the top valance
- Plain walls offer protection and save money
- Wind, UV and water resistant
- Made from durable polyester
- Quick and easy to assemble
- Canopy & walls available in four colours; Blue, black, white and red

Gazebo

Our gazebos are dual purpose outdoor displays perfect for shelter from the elements at outdoor events, and also fully branded to promote your brand and products.

Printed on UV protected, weather proof material, our gazebo displays are a great tool to grab attention throughout the year.



- Gazebo is designed to be set up by two people. We offer standard and premium gazebos, with the main difference being the thickness of the aluminium frame. Both options are available 3x3m, 4.5x3m and 6x3m. Available with single or double sided printed panels, with options for side, front and rear panels and front doors. Optional leg weights for windy conditions or hard ground.

Inflatable Tent

The Inflatable Tent is a sturdy and attractive option for outdoor displays - being a fantastic eye catching canvas providing visual advertisements that can be seen from afar.

Optional canopy and wall accessories provide more printed message opportunities and added shelter from the elements.



- Optional column & canopy colours
- Withstands wind speeds of up to 15mph/24kmh when pegged into soft ground
- Made from strong polyester with double layer PE fabric outer shell.
- Standard Carry Bag included
- Securing Straps included

Ex-Star shelter in style

The Ex-Star provides both eye-catching branding and stylish shelter from the elements. These are ideal for promotions, festivals, sports events and golf days as well as being a great alternative to a standard Gazebo or Zoom Tent.

The Ex-Star is made from quality polyester which is supported by a central pole and secured by ground pegs.



- Unusual eye-catching shape, provides branding and shelter
- Folds into a 325mm x 1470mm bag, fits comfortably into any car
- Quick to set up using 2 people
- The fabric canopy can be replaced and updated
- Quality digital print for brilliant colours and graphics
- Weatherproof, exclusive treated fabric
- Pole, pegs and bag included

Parasol branded umbrellas

Parasols & umbrellas are ideal for both indoor and outdoor retail spaces. Printing available on the entire surface using dye-sublimation technology so there is no limitation on design or colour. The Parasol makes a bright and vibrant eye-catching display whatever the weather.



Square 3.5m
• Four printed panels

Round 3.5m
• Six printed panels

Round 4m
• Eight printed panels

- 3 versatile sizes
- Printed on high quality polyester material
- 200gsm or 300gsm material choice
- Quality hard wearing product for outdoor use
- Study base for stability



Event Bar serve with a smile

Your event crowd will instinctively congregated to the alluring Event Bar Dome, digital & screen print options to the domed top and sides gives vibrant designs ensuring your message won't be missed. Used indoors and outdoors the high quality organic shape is water repellent and tough enough to tackle any conditions.

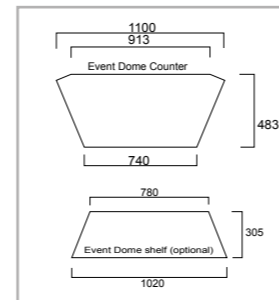
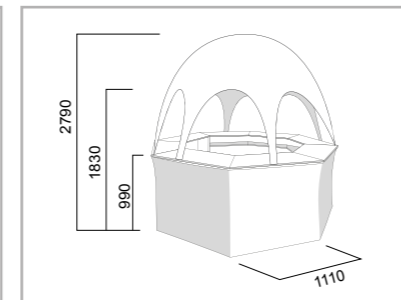
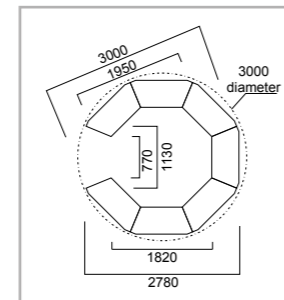

Its versatile nature allows it to be used as an information point, product demonstration showcase or a food and drinks bar. Comfortably accommodating up to four people and plenty of room for stock items, optional 'Lower Shelves' are smaller version of the counters and fit below the counter tops on the framework. Easily setup and neatly packed away, our latest outdoor shelter option is the perfect addition to engage with the crowd at your next event.



Jumbo Cabana high-vis pop-up cover

The Jumbo Cabana gives you spacious cover in seconds! High impact branded pop-up Jumbo Cabana can be used as quick day use stands, freestanding event billboards or even a quick build alternative to an event reception desk. The portable quick build Jumbo Cabana structure saves you save build time, money and wont fail to announce your brands presence at you next event.



- Assemble in under a minute
- No tools required
- Unique treated fabrics, SPF (sun protection factor) 50
- Lightweight, portable and durable and waterproof, carry bag included
- Quality sewing and workmanship
- Colourfast - printed colours that will not fade or be washed out over time
- Advanced fabric printing technology



Outdoor display stands

PVC Banners

- Cost effective solution for outdoor marketing opportunities
- Weather resistant and supplied with eyelets
- Can be produced at virtually any size
- PVC banners will continue to represent your brand for years



Banner Frames

- 2m or 3m wide x 1m high
- Single or double sided graphic panel
- UV weather resistant panels
- Quick change graphic panels
- Quick and easy set up
- Easy to transport



Mistral Lampost Banner

- User friendly display which is designed to mount printed graphic panels to lamposts
- Single or double sided graphic panel
- Maximising your brand awareness to passing traffic
- Suitable for both fabric and vinyl graphics
- Weatherproof tested in a wind of 31mph - 38mph

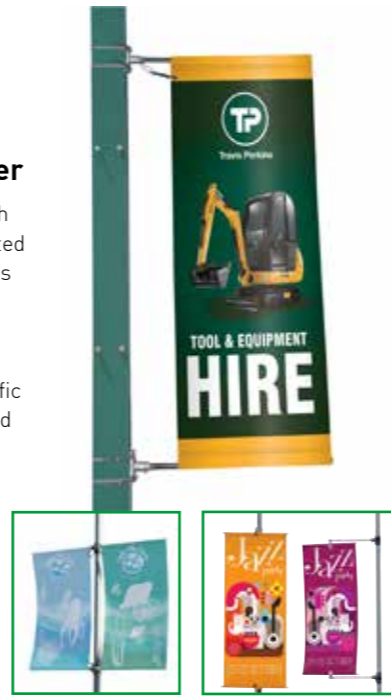

Pavement signs

Sentinel

- Bold modern design
- Base can be filled with water or sand
- Available in three heights (142.9cm, 160.3cm & 150.3cm)



Recoil Pavement Sign

- Easy front loading aluminium snap frames
- Suitable for indoor or outdoor use
- Double sided, heavy-duty construction
- Moulded base - fill with water or sand for stability
- Complete with protective graphics covers
- Optional trolley available, wheeled base
- Optional heights (119.3cm, 138.6cm & 155.9cm)



Café Barriers



- Deluxe Cafe barriers for defining areas outside bars, cafés, shopping centres and airports. Can also be used for pedestrian guidance with advertising.
- Hard wearing heavy posts, available in chrome or stylish black
- 3 Different Widths 1.2m, 1.5m and 1.8m. Can be joined together to section off any area.
- Cafe banners available in a choice of five materials – all suitable for outdoor use; Standard PVC - Black Back Canvas - Display Fabric - Airtex - Mesh PVC

Crowd Barriers



Give your event or venue branded crowd control, our printed barriers make a huge impact on the overall look of any event. Mark areas or divert queues in style. Your crowd can become part of your brand appeal at any event.

Printed on durable outdoor materials and ink that won't fade, the design hugs any custom barrier frame and then therefore have mirror your branding or have different messages either side.

- Produced at any size
- Fits any barrier
- Secure velcro fittings to attach the barrier

Classic Swing Sign

- Stylish Swing pavement sign with printed double sided metal plate. Ideal for shop fronts or forecourts.
- Available in black and white.
- Quick and easy assembly, no tools required.
- Overall size 91.5cm (h) x 58.5cm (w) x 460mm (d)



Switch Swing Sign

- Stylish Swing pavement sign, Ideal for shop fronts or forecourts.
- Magnetic poster pockets for easy changeover of posters
- Quick and easy assembly, no tools required.
- Available with A2 size posters (594mm x 420mm).



A Master

- Double sided outdoor display
- Available in seven sizes (57.4cm to 98cm high)
- Perspex anti-glare poster cover



Snapframes poster display

- Stylish Silver anodised finish
- Anti-glare poster cover sheets
- Round and square corners
- Suitable for indoor or outdoor use
- Lockable and backlit options available on request



Outdoor banner stands

Made for the outdoors

Our range of outdoor banner display stands are printed on weather proof vinyl PVC with outdoor solvent inks, the graphic panels are designed for extensive outdoor use.

Thunder



- Single or double sided
- Easy set up
- Ground pegs for windy conditions
- 85cm wide x 208cm high
- PVC weather resistant panels

Impact three



- Single or double sided
- Base filled with water or sand
- Wheeled base
- 80cm wide x 200cm high
- 20kg (when filled with water)
- PVC weather resistant panels

Blizzard



- Single sided
- Base filled with water or sand
- Range of heights
- Quick change graphic panels
- PVC weather resistant panels

Horizon Make a huge statement

Our largest outdoor graphic carrier with a print area of up to 6m² single or double sided. If your unsure your display won't make an impact outside this is the banner for you. Sturdy, hard wearing and with huge solid feet that can be filled for extra stability, the Horizon banner won't fail to be seen and won't be leaving in a hurry!



- Single or double-sided outdoor banner system
- Telescopic pole for easy installation
- Different size graphics available
- Individual units can be joined together to form a wall
- Hollow feet for water or sand weighting for total stability
- Can be used in moderate winds

Outdoor displays

Lantern banner

Lantern Banners are a new and unique indoor and outdoor display solution. Lantern Banner displays combine 360 degree visibility and movement.



- 360 display
- Glo Lantern option available
- 1.5m or 2m high
- Replacement fabric panels available
- Choice of base units
- Optional motor allows rotation for indoor use

Street flag



X-Banner



Street Flag - the perfect solution to advertise on the go. Ideal for adding value when distributing flyers in the high-street, promoting events or even your stand location.

A sturdy and lightweight backpack accepts four flag shapes, easily attached using poles supplied.

Inflatable Column

Inflatable columns are perfect for any outdoor event, whatever the weather.

Either manually pumped with the sturdy hand pump, or add an optional electric pump for setup in about one minute!



- Easily inflated from only 1 minute (with the optional electric pump)
- Can withstand wind speeds of up to 15mph when pegged into ground
- Made from a strong polyester
- Printed with vibrant outdoor inks that never fade!
- Choice of base units
- Optional motor allows rotation for indoor use



Start & Finish branded arches



POP Inflatables 3D Anything!

A unique light weight Inflatable that is easy to carry & transport. Pop inflatables are manufactured with bright, bold & eye-catching designs. If you can imagine it we can probably blow it up! Ensure your brand is seen, in any situation.



- Made with Polyester - Eco friendly recyclable fabric
- Inflatable cans from 5.5kg; 8 times lighter than PVC inflatable cans
- Advanced fabric printed technology for eye-catching lifelike branding
- Coated fabric for durability (minimal air loss and waterproof)
- Portable, light and easy to transport, one person can carry and install
- Small wind blower required due to the strong but light fabric (uses less electricity)
- Fire retardant certified

3 Popular Bottles

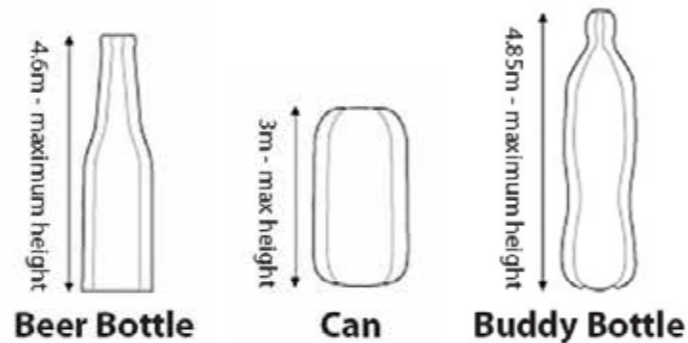

Options to suit any event

As well as a huge range of sizes and shapes our arches come in two materials to suit your event. Choose between standard PVC coated Nylon or extra thick PVC material for a stronger heavier finish.

Standard PVC

- Lightweight
- Compact
- Durable
- Easy to clean

18 colours to choose from

Premium PVC - 0.66mm

- Stronger, heavier material (similar to bouncy castles)
- Choice of constant air supply or sealed for days
- Direct print for a seamless finish
- Easy to clean

19 Colours to choose from



Our branded Inflatable start and finish arches are a great way to mark the start and finish lines at your race events. Simply plug into a power mains or generator at your event, and your branding will be the focal point at any race / running event. A simple yet high impact means of promoting your sponsorship or marketing messages, our Race Arches highlight the Start and End points, with vibrant colours that will stay colourfast when used outdoors.

Your branding can be print, sewn or fitted via velcro. Velcro branded panels allow the sponsorship details to be changed between events.



2017 Modular stands

Self Build - Advanced Build - Pro Build Modular Stands



 miragedisplay.co.uk



Build options

Self build

built for portability and self-build ease
Pages 90-94

Advanced build

more complex long-term systems
Pages 95-101

Pro build

the very best in reusable modular
Pages 102-103

Twist Modular

Flexible modular

For years Twist Banner Stands have been bridging the gap between banner stands and Pop Up exhibition display stands.

A popular stand for self builders, you can start with a small display solution and adapt and build to create fully flexible modular solutions.

Twist stands can be seamlessly linked together with the 55cm wide patented Flexi-Link graphic panel. Flexible fittings enable Twist stands to be linked together at almost any angle.

Create sweeping curves at any angle you require with the Flexi-Link panel. Flexi-Link curves give the ultimate in flexible display stands, ensuring that your stand copes with unexpected obstacles.

The Easi-Link kit is used to link Twist Display Stands to create a flat wall or backdrop. Create the ultimate bespoke exhibition stands by utilising both Flexi-Link panels and Easi-Link kits.

We can help you to visualise a bespoke Twist configuration with our free In House design service. Simply give us the stand spaces you want to use your Twist stands in, and we will put together clear 3D drawings showing you the best possible configurations.



Centro Modular static system evolved

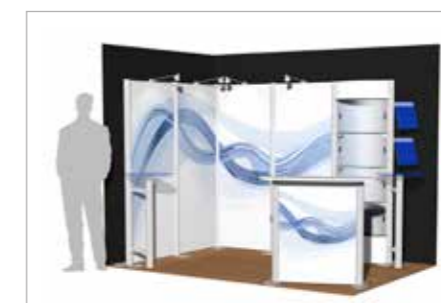

Centro frame goes modular

Centro System frames have been a favourite over the years bridging the 'portable vs. quality' gap, enabling graphics to be used over longer periods as static displays.

The simple yet secure click and lock alloy frame looks smart, offers a quality sturdy feel and can be easily self installed. The Centro family now has premium options that cover a range of display solutions. Shelving, AV and literature holding brackets, lights, poster displays and complete large static graphic walls that can use straight or curved profiles.

These multiple display options can now be combined to produce a complete modular solution, the benefits with Centro Modular is continuity, simple fixings turn individual Centro components into a stylish exhibition display enabling you to easily move into the modular exhibition market in style.

With 10 years of development and continued supply is the perfect choice for customers who wish to build on existing kit and expand into modular or new exhibitors to enter the market with confidence, knowing they can grow into modular options well into the future.

- Strong & stylish 'quick lock' build
- Quality assured - 5 year guarantee
- Shaped silver bases ensure stability
- Adaptable with the Centro range
- Wall, shelving and poster displays function individually
- Substrate options, traditional banner, flexible PVC or ridged Foamex
- Grow your system over time
- Self build and easy transport
- 3d rendered drawings available

Impact modular system

Make the move to modular

This is a popular option for our customers that want to take the first step into large adaptable modular systems but don't have the budget, flexibility or can't afford to lose the portability of the smaller back drops they have used in the past.



- Cost effective - make the modular step on a pop-up budget
- Modular - parts altered to make a fully modular display with different widths and heights
- Curved or flat ends, curved or flat walls, variable heights can be achieved
- Optional fittings - TV holders, shelving, lighting
- 3D drawing service available - plan before you buy
- Portable - the Impact Modular can break down and be transported in a few wheeled cases



Customise shapes

Internal shelving, variable heights and shapes, lights even curtained storage areas can be incorporated.



Accessories to grow with you

The Impact Modular is an advanced portable system which takes small back-drop system technology and pushes what you can do with the concept to new heights, available with many simple features usually only seen in high end modular systems.

Monitor holders, end panel lighting, internal and external showcase shelving, variable heights, private storage areas, frame modifications and fully adaptable graphics that make the display adaptable to future events for years to come.



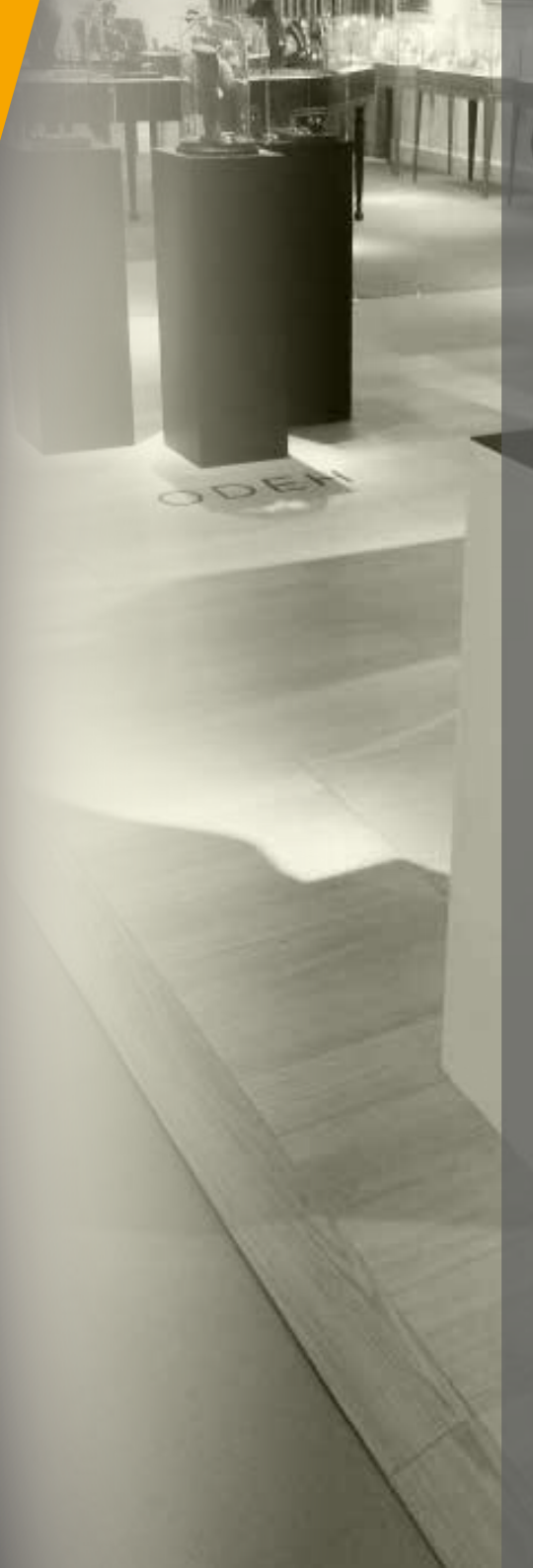

Floortable perfect finish

Modular Systems begin at the base

A fully modular and adaptable floor system, popular with exhibitors that have repeated exhibitions and can save time and money purchasing their own hard wearing, professional looking floor that lasts for many years.

The raised floor allows cables to be hidden seamlessly and ramped edging gives the whole look a permanent floor look & feel, complimenting any exhibition space.



- Flooring comes in panels that interlock
- Once fitted no movement in any plane or direction
- Can be fitted quickly by one person without tools
- Space under the floor to run cables
- Available in four of our most popular colours
- Other colours and printed options available to order



Finished to suit any event

Available in our most popular textured colours, black, lugano, light maple and metalika. Solid flooring that looks like its always been there, other colours and printed floors available on request.



Aluminium frame with tensioned fabric graphics



- 5m x 2.5m and 3m high walls are popular choice for straight walls
- Add a popular 2-3m stretch ceiling mounted display
- Design your display for a quality yet quick-build, portable option
- Quality construction for long term use
- An alternative solution to traditional portable display stands
- Create curved or straight walls for a bespoke set up

Stretch fabric modular system

Freestanding benefits

Part of our stand-alone Stretch Freestanding system, the Stretch Modular is a great option when you need to create a high impact, yet cost effective display for an L or U shape space.

Make a statement at your next event.

How it works

Stretch Modular framework has two channels for the insertion of branded fabric panels with a silicone strip sewn onto the edge of the graphic

This silicone strip fits securely into the framework channel, gripping the fabric and stretching it across the display surface, removing any creases.

Fabric graphic panels can be produced for both the front and rear of the frame, to create a double sided bespoke shaped display stand.



Clever Frame

Smart investment

Clever Frame, the impressive multi-function exhibition system that's exciting exhibitors the world over with its clean design and almost endless, versatile configuration options.

Give your display the competitive edge with a stylish system you can easily design, build and grow your Clever Frame system years ahead of the competition.

Look great, adapt at your convenience and self-build with ease. Clever Frame, Clever Form, Clever Design.



Drawings that impress

Clever Frame can be supplied with beautifully rendered 3d visuals and plans to help present and promote your ideas.

Don't forget our complete Advanced-build installation and storage options, no time to worry about the logistics of event installs?

With Advance build we can take care of it all.

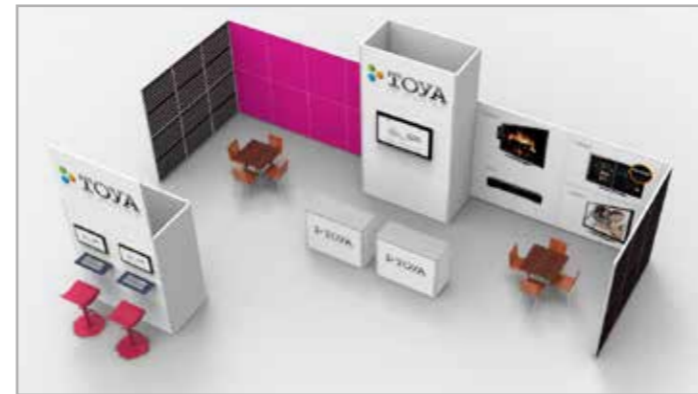

What is Clever Frame?

Building blocks for marketers. A system of reusable aluminium frames, able to connect with each other in any configuration. Exchangeable panels and a huge range of accessories, the system is adjustable for all event situations.

Award winning design, the next generation of self-build systems. Inter-connecting aluminium frames can be configured into almost any form or structure. The system is so robust and simple to build (no tools required) you can be confident your initial outlay will last you years on the exhibition circuit.

Unlimited opportunities

One system can give you an array of possible shapes and configurations.

These four systems have been built with 12 Clever Frame 'blocks' and interchangeable graphics.



Easily manipulate frames to different sizes and structures for different events, and update sections of graphics without having all panels replaced. The graphic panels, are secured by magnet to the face of the frames to give near seamless single or double-sided graphic coverage.

Build exhibition stands and private booths, enhance your brand awareness with event scenery, backdrops and sponsor walls. Improve your work space by creating visually impressive reception areas and office dividers.

The configuration options really are endless...

- Intuitive tool-less assembly
- Stylish visuals - Includes 3d visuals & plans
- Huge range of quality stand accessories
- One frame - Dozens of configurations
- Long term cost effective investment
- Portable and easy to transport
- Change layouts to suit venues
- Update or rearrange graphics with ease





Gantry modular system

Modular Low Cost Exhibition Stands

Gantry is ideal for creating very bold and striking exhibition stands, at a fraction of the cost of traditional bespoke options.

With exposed lightweight aluminium beams that are extremely strong allowing a load bearing span of up to 60m. Supplied in framework sections, Gantry can be used to create any shape and size exhibition or display stand.

The modular nature of the framework allows for the size and shape to be reconfigured between events. Therefore, one gantry exhibition stand can be designed to fit a range of exhibition requirements throughout the year.

Ideal for companies wanting to have one exhibition stand that can be used in a space only site, and also in smaller shell scheme spaces.

After discussing your requirements we can put together 3d Cad drawings showing how a Gantry system will fit your exhibition spaces. If you want to use a Gantry modular exhibition stand at different sized events throughout the year, we can put together drawings to show how a Gantry system can be used for all of your events.



T3 shell clad



Shell kits with style

T3 Shell-Kit has been designed with simplicity, adaptability for different venues and maximizing available space. Built around the T3 Shell clamp, which can be fixed to any shell scheme world wide, without any tools, creating seamless fabric display environments

Using the same T3 frames as the modular system and the shell connectors your kit connects effortlessly to any shell system and maintains a 60mm clearance from the existing wall and floor, maximizing your floor space.

Cladding options included ridged foamex panels or seamless ultra compact fabric graphic walls. The system breaks down into manageable lengths for easy transportation, with the average 3x3 fabric shell scheme fitting in a frame shoulder bag.

Fully adaptable in size and shape you can extend or reduce your system to fit different event spaces, giving you not only a unique looking stand but one that's cost effective for future displays.

- Fast, simple and easy to fit
- No tools required
- Can accommodate screens, plinths and storage spaces
- Fits any shell scheme with unique clamp
- Reconfigures into larger freestanding displays
- Designed to free up floor-space

T3 modular system



Revolutionary custom built

A patented cube and connector is used to create truly unique exhibition stands, simple to use, almost limitless in adaptability and form.

Using the T3 system we can design and produce superb individual structures that can be assembled by any end user. Alternatively if you need full build, delivery, construction and storage there is also the added feature of our low cost site setup service.

T3 enables exhibitors looking to compete with elaborate custom built exhibition, normally associated with extreme budgets. These usually need huge build teams that require complex timber structures which are often expensive and difficult to adapt beyond the one event. Unlike many of these custom-built exhibition stands, T3 can be used again and again with no additional costs.

T3 meet complex system demands

- Create unique exhibition stands
- Custom built exhibition stands that won't leave you out of pocket
- Adaptable in size and shape, easy to update graphic panels
- Strong enough to support plasma screens and heavy display items
- Internal product / literature display
- Create secure storage areas
- Choice of roll up, foamex, fabric and acrylic graphic panels
- No tools or skilled labor needed to assemble stand
- Individual frame components lowers maintenance bills on replacement parts

T3 modular system

Ideas to exhibition

Although this is a modular system, each display stand we produce is a bespoke creation.

Our in-house design team can create a 3D visualisation of your new exhibition stand.

To start this work we would need to take a brief from you;

- What size floor spaces does the display need?
- Does the floor space have a back or side shell walls?
- Do you require LCD screens?
- Do you need to display products or need storage?
- Are there any height restrictions?
- Are there any other special requirements?
- Are there any other special requirements?
- Are there any other special requirements?



Ideas in motion backlit fabric extension

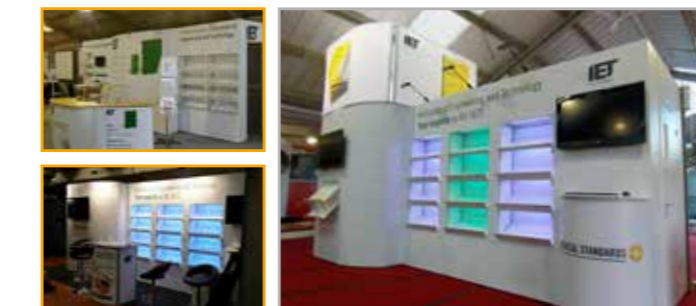

T3 stand today has a long tradition of adaptability, the IET T3 stand is totally unrecognisable from its first revision many years ago.

Simple storage and built in monitor requirements have evolved with the needs of the exhibition stand.

The system now has a removable fabric height extension that is back lit, allowing it to be seen far and wide at many of the larger events across the country, yet still able to fit neatly into the smaller ones.

The shelving with its rotating coloured lights makes it instantly recognisable and really highlights the IET event product, their industry manuals.



ISOframe Wave



Preium framework

The Wave is our premium fully flexible portable exhibition display system.

Stunning looks, superior build quality, infinite flexibility and extremely user-friendly.

The build quality is reflected in the components. Hard wearing easy to assemble and reusable for year to come.

Were so confident the ISOframe Wave comes with a lifetime guarantee!



- Portable - graphics roll up into tubes, holdall bag holds framework
- Flexible, reduce or expand your exhibition stand to suit the floorspace
- Easy to build, no tools, DIY construction
- Hardwearing for regular use
- Range of accessories, shelves, lighting, literature stands, counters and monitor holders
- Storage areas can be added
- Variable Heights 2090mm, 2290mm, 2490mm



• 3D Drawing Service for planning available

Did we mention flexibility?

ISOframe Wave is the first portable exhibition display system that can be formed into any shape.

With its compact nature the ISOframe Wave is also easily transportable and is assembled without tools.

You can even extend or reduce the display without re-printing graphics. This quality product will grow with your company and exhibition ideas for years. Its so flexible even if it the system needs to be repositioned or reshaped during your event it can be done without taking graphics down, our customers love the fact is totally versatile and can be reused again and again and repositioned with ever changing exhibition floor spaces.

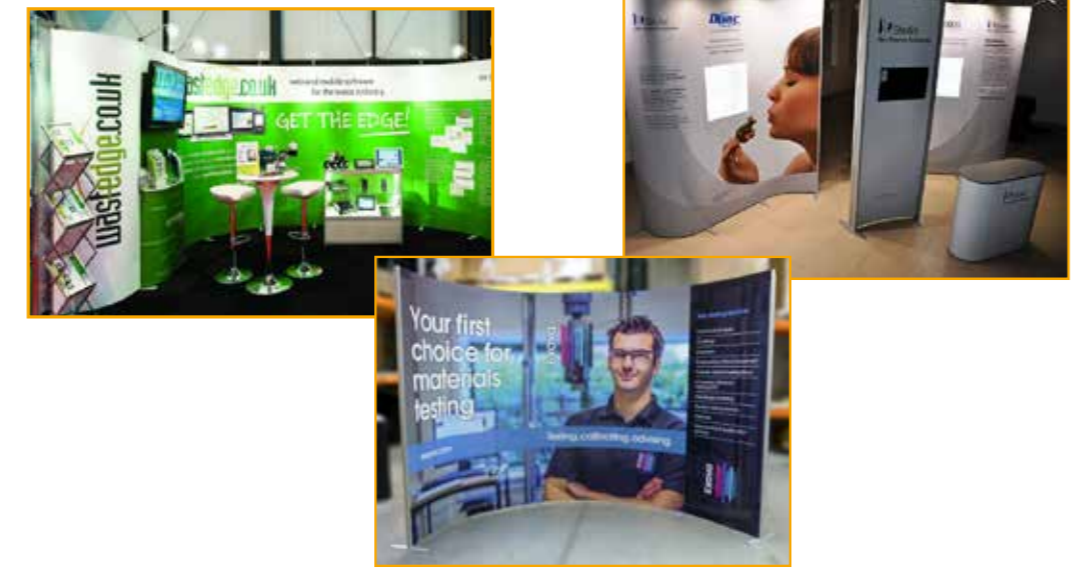

ISOframe Counter

Bespoke pro counters

Part of the ISOframe range, compliment your exhibition with premium quality counters, with looks and build quality that will never let you down.

Ideal for use as either product podiums or work surfaces, due to their build quality and ISOframe construction they can take unusually high loads either on the surface or the optional shelf. Counters are available in a five main shapes and standard height options from 250mm to 1000mm.



- Fast and easy tool-free assembly
- Flat-packs easily into a car
- Use as counters or product display podiums
- 250, 500, 750, 890 and 1000mm height options
- Optional adjustable internal shelving
- Upgradeable to a maximum load of 75Kg



Variety and quality are standard

The ISOframe Counter compliments the professional build quality and standards set in the ISOframe modular range. With five different shapes, all available in different heights for a variety of uses you can't help but show your serious side.



Moves with you

Transport as a flat pack and assemble in seconds. Graphics can then be easily attached magnetically and stored safely. Each counter can be accessorised with a range of components such as shelves and doors for secure storage, or visual elements such as iPad holders.

Linx 'business class' modular system



Professional custom exhibition display

Is it time to move your ideas in modular to the next level, would you like to create a stunning system that will raise your companies profile and professionalism at any large-scale show? If you have been placed in charge with the task to meet this challenge, we may just have the complete pro-system to achieve your vision.

Linx modular is our complete premium service and superior display system. From the moment we take your ideas to the delivery and build, your assured of the best quality at every stage. Linx uses a high-grade frame construction that produces incredible structures, which mix architectural shapes and vibrant graphics to create cutting edge stands that grace any design portfolio.

Linx high-end systems don't have to come with high-end budgets usually associated with traditional bespoke build systems. The aluminium frame used is a fully reusable structure and can be adapted for different frame designs for future use. This enables you to either buy the stand outright, hire sections or even the entire stand. This gives you full flexibility to meet not only meet your brief of a spectacular stand, but also to come in on budget!



- AutoCAD drawings to fully visualise your creation
- High-grade aluminium frame systems pre-built and tested
- Full service - storage and delivery of your system ready for the big day
- Logistics and construction handled by our full onsite build team
- Exhibition take-down, transportation and long term storage included
- Event day; Relax, enjoy the show and prepare to engage your audience

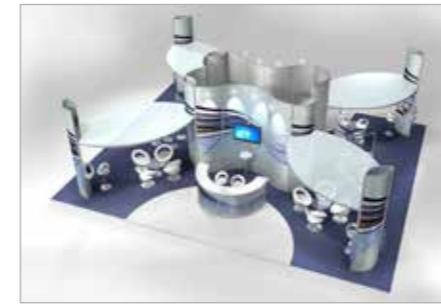
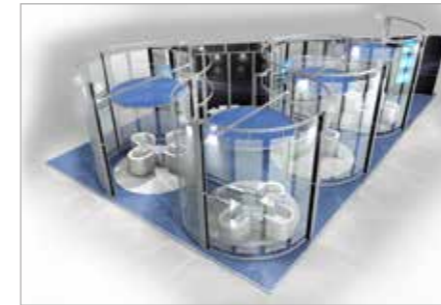
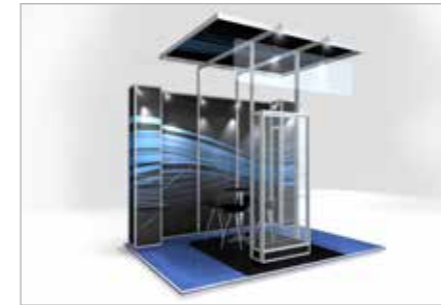

Bespoke plans

Better by design

From initial concept and brief, right through to production and final build, you will be able to clearly visualise your complete Linx display system.

At each stage of the design your ideas are beautifully displayed with detailed plans and dazzling 3d renders.

Meticulous drawings and plans are always on hand, including detailed frame instruction and layouts to be used on the day of the build.

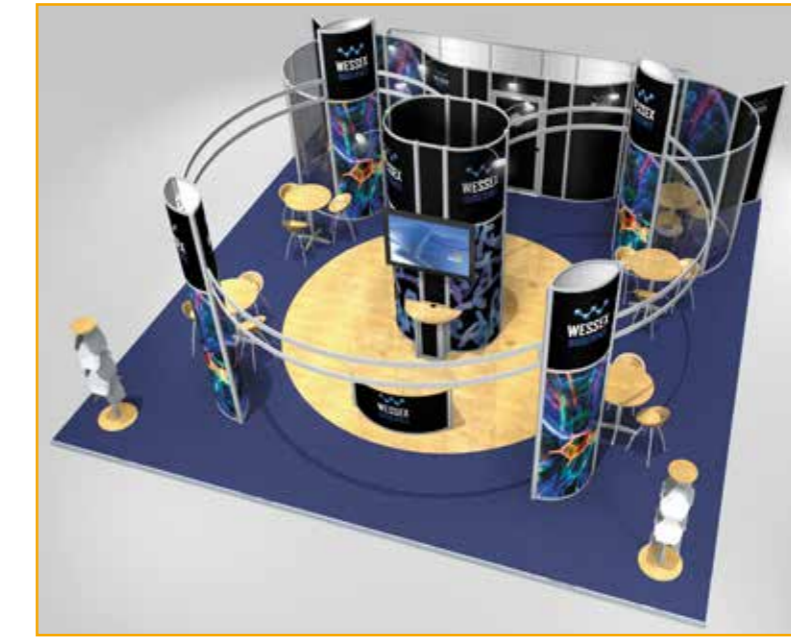
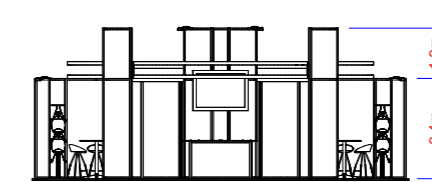
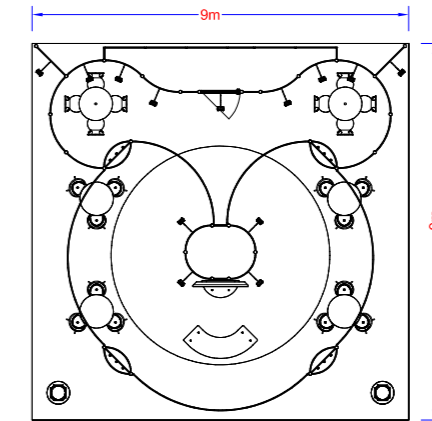



Mirage Display Ltd - Stockport UK - **0161 482 7997** - enquiries@miragedisplay.co.uk - www.miragedisplay.co.uk