

SEALPRO120

The world's best fully automatic laminate cutting and thermo sealing machine for rolled wipes in canisters



THE SEALPRO120 automatically cut the sealing laminate according to your product size and thermo-seals it, accurately. It has 6 individually temperature controlled welding heads, all built inside one robust sealing block.

Quick Fact Sheet:



- Fully automatic
- Throughput models offered: 60, 120 & 200 products per minute
- Supporting both oval and round canisters
- Minimum foil waste, intra batches: 15mm-20mm, **reducing waste!**
- Minimum foil waste, inter batches: 15mm-20mm, **reducing waste!**
- Tolerance: margin 3-4mm, trim 10mm, **reducing waste!**
- Sub 20 minutes changeover, **reducing downtime!**
- Sanitary design for highest standards of rolled wipes production
- Sealing strength tuning and fine-tuning per each sealing head may be done separately via the HMI
- Explosion-Proof, Lid-Intrusion and "Breathing Foil" upgrades available
- Over 60 machines sold

Machine specifications:

Canister

Dimensions	Diameter		Height	
	Min: 75	Max:130	Min:100	Max:280
Canisters per sealing cycle	6 units			
Machine throughput	120 canisters per minute			
Shapes supported	Round and oval canisters			

Waste Control

Tolerance	Margin 3-4mm trim (including margin) 10mm	
Minimum foil waste, intra batches	15mm-20mm	
Minimum foil waste, inter batches	15mm-20mm	

Sealing Foil

Foil type	Most of the industry standard PE based sealing laminates	
Width	Min:140mm	Max: 180mm
Roll Diameter	Max: 260mm	
Roll Core Diameters	3"	

Machine Control

Safety controls, emergency stop & doors	Wired through category 4 controller	
HMI Display	Siemens	
PLC	Siemens	
Sensors	Omron or Sick	
Voltage	US: 3x208V, 16A	Europe: 3X380V, 10A
Pneumatics	Festo or SMC	
Air Supply	6 ATM, 9 liters/M	

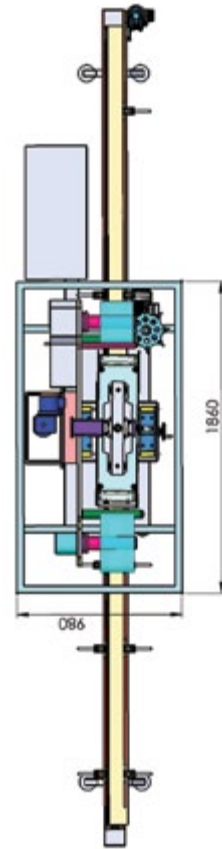

Explosion-Proof, Lid-Intrusion and "Breathing Foil" upgrades available

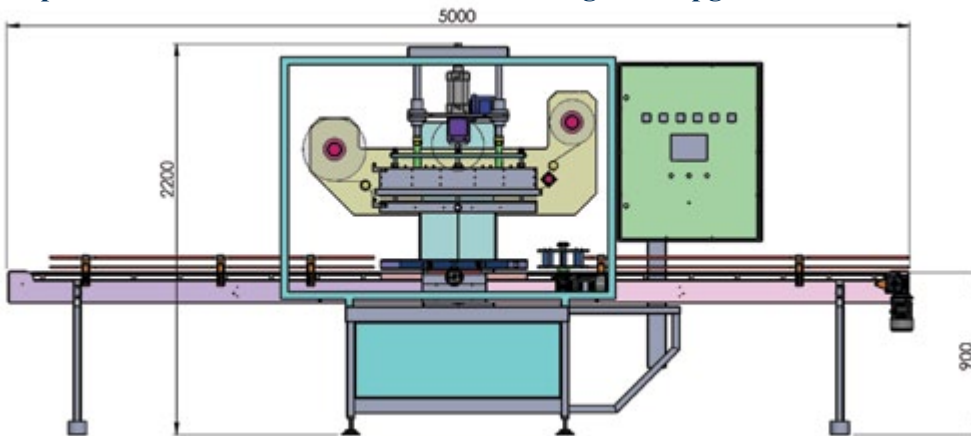

United Kingdom
 Shemesh Automation UK
 Contact: Mr. Shai Shemesh
 Tel.: +44 207 887 6004
 shai.s@shemeshautomation.com

Japan & Indonesia
 Shemesh Automation Japan & Indonesia
 Contact: Mr. Kentaro Taguchi
 Tel.: +81-(0)3-3278-6122
 taguchi.kentaro@moritani.co.jp

Germany
 Shemesh Automation Germany
 Contact: Mr. Alexander Herzog
 Tel.: +49 5261 6678 245
 Herzog@herzog-services.com

Asia ex Japan and Indonesia
 Shemesh Automation Asia
 ex Japan and Indonesia
 Contact: Mr. Charles Yip
 Tel.: +852-28909218
 charles.yip@tech-vantage.net

France
 Shemesh Automation France
 Contact: Mr. Jean-Mark Bernard
 Tel.: +33 2 47 66 24 97
 jmbernard@jmbpackaging.com

North America
 Shemesh Automation NA
 Contact: Mr. Jay Roth
 Tel.: +1717 637 5991
 jroth@elsnereng.com

Israel
 Shemesh Automation Israel
 Contact: Mr. Gal Vardi
 Tel.: +972 3 550 9946
 gal.v@shemeshautomation.com

South America
 Shemesh Automation South America
 Contact: Mr. Ricardo Leon
 Tel.: +574 268 8631
 rwleon@une.net.co

