

**ROTOLOK**

everything under control...

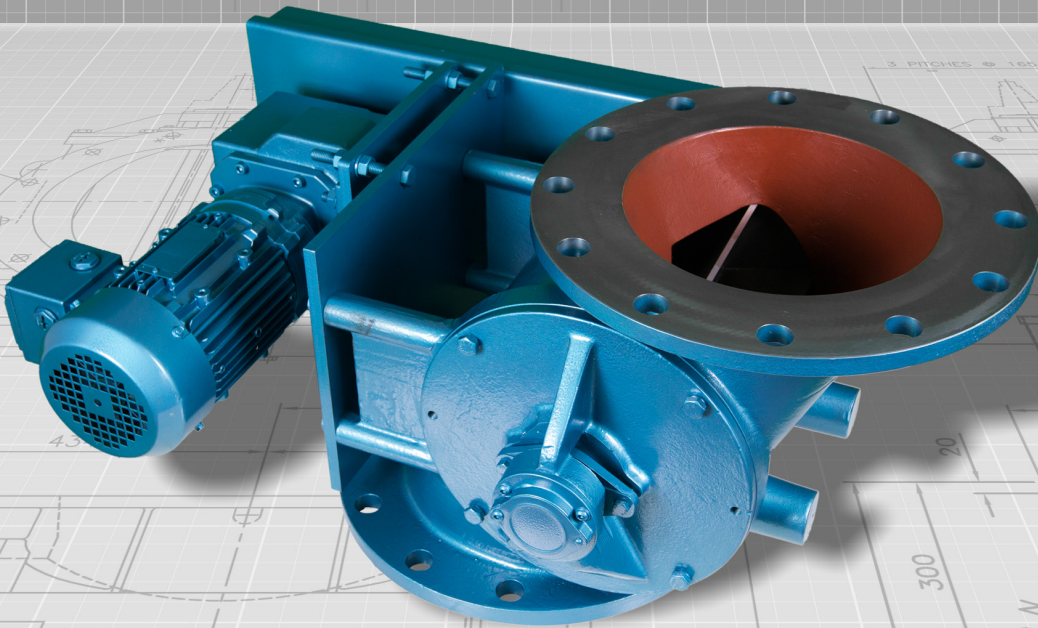

OFFSET ROTARY VALVES

**ROTOLOK UK**

1 Millennium Place  
Tiverton Business Park  
Tiverton  
Devon  
EX16 6SB  
United Kingdom

Tel: +44 (0) 1884 232232  
Fax: +44 (0) 1884 232200

[www.rotolok.co.uk](http://www.rotolok.co.uk)  
[sales@rotolok.co.uk](mailto:sales@rotolok.co.uk)



## INTRODUCTION

The main function of a Rotary valve is to regulate the flow of materials from one chamber to another while maintaining a good airlock condition. The material or product being handled is usually dry free flowing powder, dust or granules.

The granule type of product, especially if it is a hard type: plastics; polyethylene; nylon etc., does not shear easily and consequently, without considerable care the standard drop-through type of valve can seize and also experience considerable shock loadings.

To minimise these problems the Offset Rotary Valve ensures lower pocket fillage as its design means that the rotor is still being filled in an upward cycle with the pellets falling away at a shear point. Similarly, the pelican beak distributes the product across the full width of the rotor.

## IMPORTANT FEATURES

- Maximum number of blades in contact with body at one time without affecting throughput
- Good throat opening at valve entry allowing high pocket fillage efficiency
- Robust body adequately stiffened to prevent distortion
- Heavy shaft diameters minimising deflection
- Outboard bearings for non-contamination
- Packing gland type seals
- Maximising valve speed to 25 RPM prolonging life, ensuring good throughput
- Precision machining of components
- Options available for specialisation

## SPECIFICATION

### BODIES

Cast Iron, Stainless Steel or Aluminium precision bored

### END COVERS

Cast Iron, Stainless Steel or Aluminium spigot located in body for concentricity

### ROTOR

Fabricated Mild or Stainless Steel

### BEARINGS

Generally sealed-for-life-ball type rigged outboard or high temperature above 250°C

### SHAFT SEAL

Gland type with PTFE packing

### DRIVE

TEFC geared motor unit side wall mounted to valve body and complete with taper lock sprockets chain drive all in an enclosed guard

## OPTIONS

We have several additional options available including:

- Body Vents
- Air Purge Glands
- Quick Release Rotors
- Direct Coupled Drives
- Hard Chrome Internals
- Electro-less Nickel Plating
- Shear Plate Deflectors
- Speed Switch
- Dropout Boxes
- V.S. Drives
- Flameproof Motors
- Vent Boxes etc.

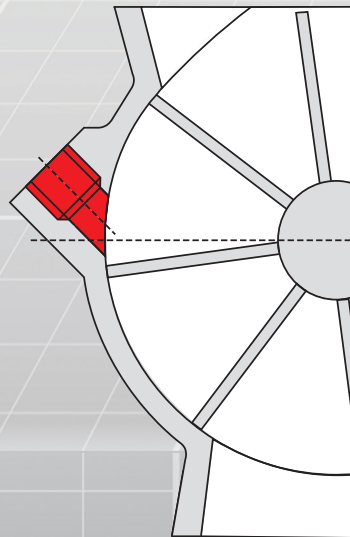

Body Vent

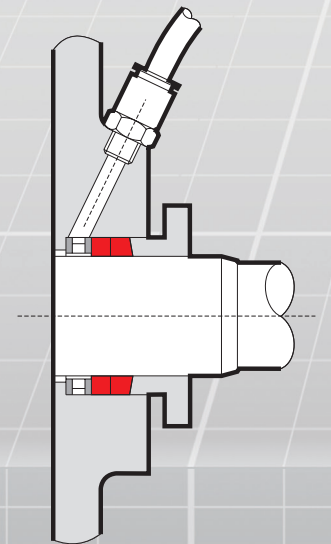

Air Purge gland

## OFFSET RECTANGULAR VALVES

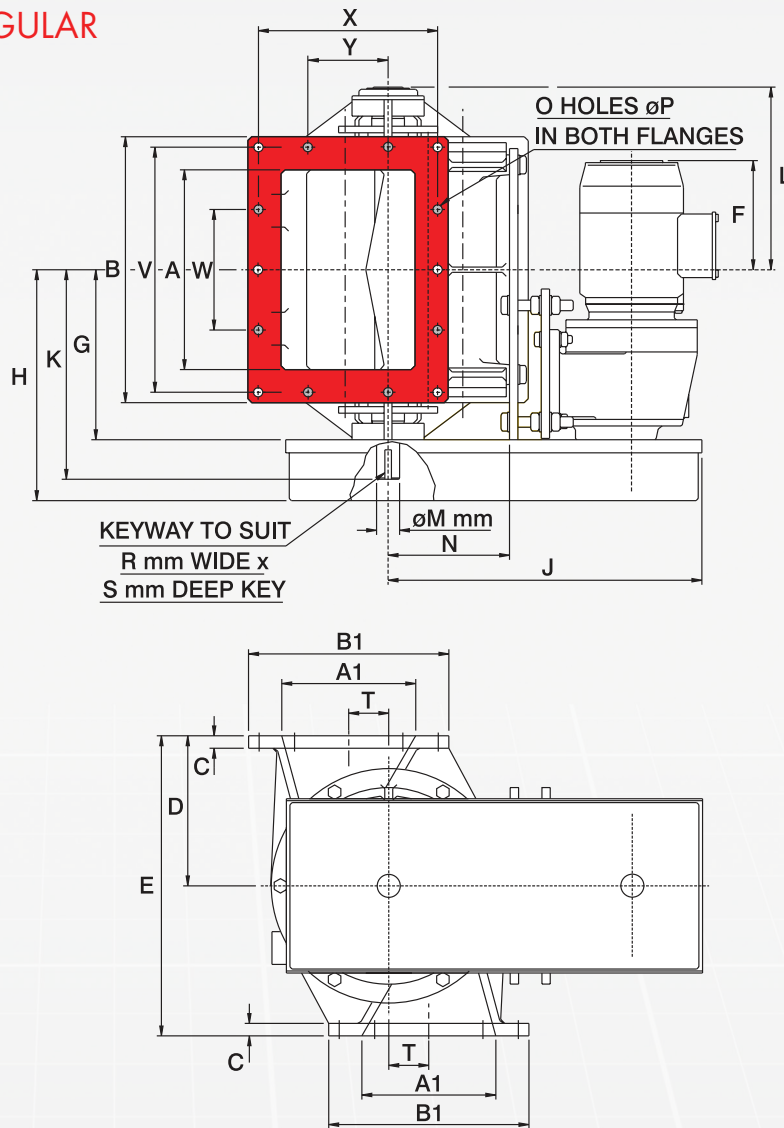

All dimensions are in millimetres

SIZE	A	A1	B	B1	C	D	E	F	G	H	J	K
200	200	152	305	254	12	165	330	247	199	281	438	260
250	254	178	356	280	15	204	408	232	229	311	466	290
300	305	204	406	305	19	229	458	230	260	363	496	320
400	406	254	558	406	22	279	558	155	332	434	626	403
450	458	280	610	432	22	327	654	205	357	459	666	419
500	508	305	660	457	25	356	712	180	382	484	666	453

SIZE	L	M	N	O	P	R	S	T	V	W	X	Y	kW
200	218	28	133	8	14	8	7	41	273	178	222	127	0.75
250	248	35	155	8	14	10	8	48	324	152	248	152	0.75
300	279	35	185	8	14	10	8	61	374	184	273	165	1.1
400	351	50	235	14	19	14	9	86	514	266	362	152	1.1
450	376	50	260	14	19	14	9	86	565	280	387	152	1.1
500	401	50	285	14	19	14	9	99	616	304	413	152	2.2

Dimensions are approximate and subject to change without notice  
 Planning-in detail for general guidance only  
 (To cover safety aspects ask for our safety leaflets)  
 Drillings are Rotolok standards. Variations can be made.



## OFFSET CIRCULAR VALVES

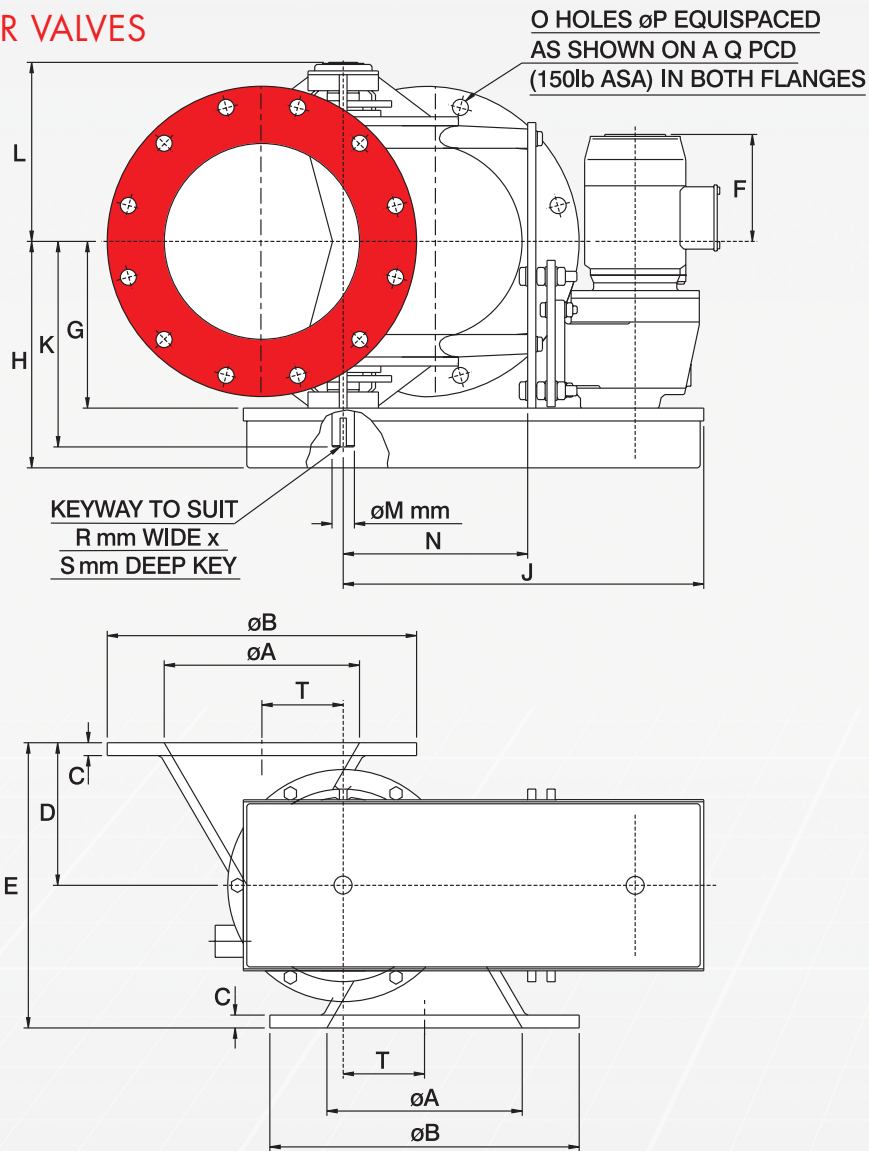

All dimensions are in millimetres

SIZE	$\varnothing A$	$\varnothing B$	C	D	E	F	G	H	J	K
150	152	279	13	127	254	248	174	256	475	234
200	204	343	16	165	330	250	199	301	517	260
250	254	406	19	190	380	220	229	311	564	290
300	305	483	20	222	444	227	260	362	626	320
350	356	533	22	266.7	533.4	217	270	372	652	329
500	508	700	25	356	712	180	382	484	747	453

SIZE	L	$\varnothing M$	N	O	$\varnothing P$	$\varnothing Q$	R	S	T	kW
150	194	28	201	8	22	241	8	7	76	0.37
200	218	28	200	8	22	298	8	7	86	0.75
250	249	35	247	12	25	362	10	8	108	0.75
300	279	35	288	12	25	432	10	8	127	1.1
350	289	35	330	12	28	476	10	8	140	1.1
500	404	50	365	20	32	635	14	9	200	2.2

Dimensions are approximate and subject to change without notice  
Planning-in detail for general guidance only  
(To cover safety aspects ask for our safety leaflets)  
Drillings are Rotolok standards. Variations can be made.





## VALVE SELECTION

The chart below gives theoretical and practical throughputs on the basis of rotor speed.

The theoretical efficiency is seldom achieved in practice as density, product characteristics, pressure differentials, feeding methods etc. all affect valve throughput.

On these considerations the practical figures are assessed and are more acceptable for correct valve selection.

e.g. Select a valve to process 7 1/2 tonnes/hour of flour at 545kg/cu.metre.  
Volume required =  $7.5 \times 1000/545 = 13.75$  cu.metre/hrs

From the chart the 300 unit running at 14 RPM covers this requirement.

Certain products when fluidised can exceed the conservative ratings. Similarly, light products - 160kg/cu.metre the opposite effect can occur.

CAPACITY CHART IN CUBIC METRE/HR														
VALVE SIZE		ROTOR SPEED RPM												
		1	5	8	10	12	14	16	18	20	22	24	26	
500		5.82	29	47	58	70	81	93	105	116	128	140	151	100%
		5.82	29	45	52	62	70	78	85	90	95	99	103	Practical
450		4.20	21	34	42	50	59	67	76	84	92	101	109	100%
		4.20	21	32	38	44	51	56	62	66	68	72	74	Practical
400		2.94	15	24	29	35	41	47	53	59	65	71	76	100%
		29.4	15	23	26	31	35	39	43	46	48	50	52	Practical
350		1.86	9.3	15	19	22	26	30	33	37	41	45	48	100%
		1.86	9.3	14	17	19	22	25	27	29	30	32	33	Practical
300		1.26	6.3	10	13	15	18	20	23	25	28	30	33	100%
		1.26	6.3	9.5	12	13	15	17	19	19	21	21	22	Practical
250		.720	3.6	5.8	7.2	8.6	10	12	13	14	16	17	19	100%
		.720	3.6	5.5	6.5	7.6	8.6	10	11	11	12	12	13	Practical
200		.358	1.8	2.9	3.6	4.3	5.0	5.7	6.4	7.2	7.9	8.6	9.3	100%
		.358	1.8	2.8	3.2	3.8	4.3	4.8	5.2	5.6	5.8	6.1	6.3	Practical
150		0.143	0.72	1.1	1.4	1.7	2.0	2.3	2.6	2.9	3.2	3.4	3.7	100%
		0.143	0.72	1.0	1.3	1.5	1.7	1.9	2.1	2.3	2.3	2.3	2.5	Practical
		1	5	8	10	12	14	16	18	20	22	24	26	

### NOTES:

#### THROUGHPUT

Certain products when fluidised can greatly exceed the conservative rating and on application, e.g. cement, 100% pocket fillage has been known to occur. Similarly light products, up to 160kg/cu.metre, the opposite can occur.

#### TEMPERATURE

On an application above ambient (21°C) it is important to specify operating temperatures so rotor compensation for expansion can be machined as necessary.

#### CONVERSIONS

Multiply cubic metres/hr by 35.31 to obtain cubic feet/hour.

Theoretical capacity 100% pocket fillage efficiency.

Conservative estimates throughput.

## OTHER ROTOLOK PRODUCTS

As well as the Offset Rotary Valves, Rotolok manufacture and supply a range of other products in Cast Iron for use in conveying systems.

These include, but are not limited to: Blo-line pipe coupling; Slide Gates with Pneumatic, Motorised or Manual operation; Rotary Valve; Dust Collector Valve; Roundhead Valve; Blowing Seals and various Diverter Valves.

For more information, please visit our website or contact our sales team.

A Standard Rotary Valve that can be made to suit most applications with a variety of construction materials and rotors

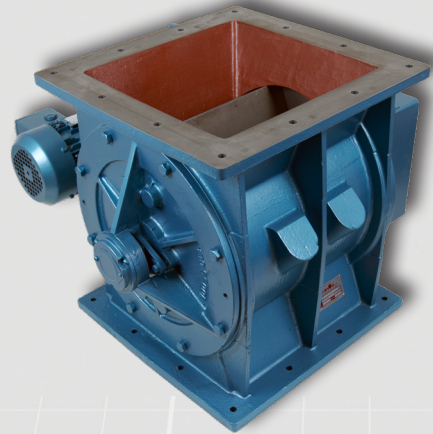

A Cast Iron conveying diverter valve. Available with flanged or spigotted connections to fit existing conveying systems

A typical Blowing Seal with a square inlet used in pneumatic conveying systems.

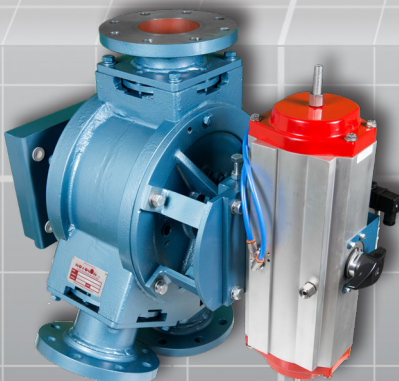
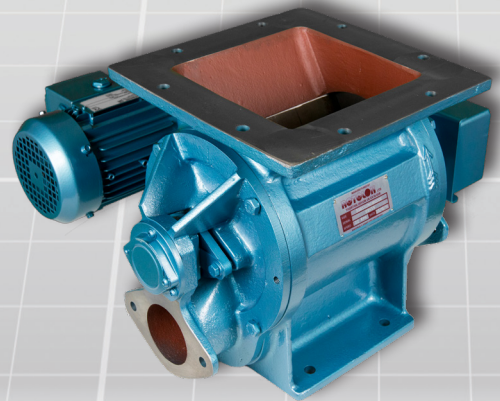

A Standard Plug Diverter Valve. The valve has a rugged cast iron body and is suitable for abrasive or high pressure applications

