

ROTOLOK

everything under control...



PLUG DIVERTERS

ROTOLOK USA

Industrial Ventures II
2711 Gray Fox Road
Monroe
North Carolina
28110
United States of America
Tel: +1 (704) 282 4444
Fax: +1 (704) 282 4242
www.rotolok.us
sales@rotolok.us



INTRODUCTION

Plug type diverter valves are used in the pneumatic conveying industry to re-route powder, pellets and granules from one discharge point to another.

The Rotolok Plug Diverter can be used where Flap Valves are unsuitable due to high pressures or abrasive duties.

Plug Valves are ideal for use in high vacuum conveying systems or where severe leakage or cross contamination cannot be tolerated.

THE PLUG DIVERTER

The Valve consists of a rugged cast body which houses a cast plug between a pair of end covers. The material handled passes from one line through a tunnel within the plug to either of the two outlet lines. The material stream is diverted to the selected outlet by rotating the plug through 150°. Rotation is alternately clockwise and counter-clockwise and is achieved by means of a double acting torque actuator.

To prevent cross contamination, each leg has individual PTFE seal to the plug which is pressurized by a gland follower arrangement and is accessible, adjustable and replaceable externally.

The plug and body are precision machines using the latest CNC technology to ensure reliability and sealing efficiency. The valve has no dead-leg, smooth internals ensure no lodgment points, minimizing turbulence and therefore ensuring line efficiency is kept to a maximum.

Pipe connections can be supplied as either plain pipe ends or flanged as required.

FLANGED CONNECTIONS

Simple and robust, bolt on flanged ends drilled to match various international standards.

SPIGOTTED CONNECTIONS

The spigotted ends are connected to pipework with 'Blo-line' type couplings, facilitating quick access in case of blockages. It also gives flexibility in pipe length accuracies and misalignment variation. Furthermore, the Rotolok spigotted ends are not of cast fixed length, but bolted on and of variable length. This enables the ends to be supplied to fit exactly to existing pipework.

IMPORTANT FEATURES

- Suitable for all types of conveying systems and most materials
- Compact design
- Small divert angle - 30°
- Smooth internals - no lodgment points
- Minimal air leakage and cross contamination
- Pneumatic and/or manual versions
- Rugged design for upset pressure up to 10 Bar (145 p.s.i)
- Simple access and maintenance
- Aluminum, Cast Iron or Stainless Steel construction

RANGE

A choice of construction materials include Aluminum, Cast Iron and Stainless Steel in any combination, allowing the majority of applications to be catered for. Standard range size 3" to 10" diameter but we will extend this range should the need arise.

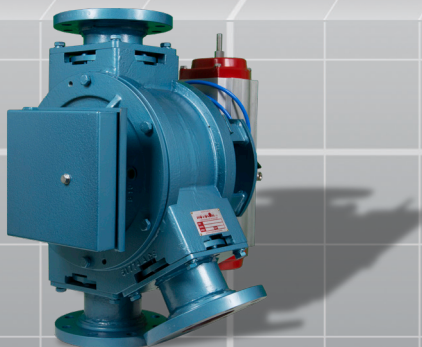



PLUG DIVERTERS

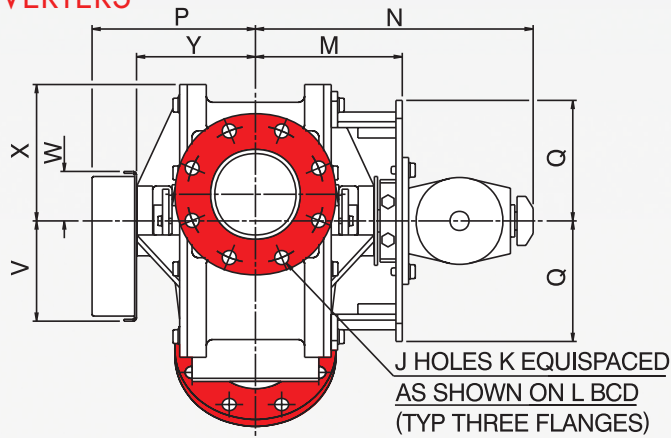

NOTE:
10" size has two actuators,
one either side.

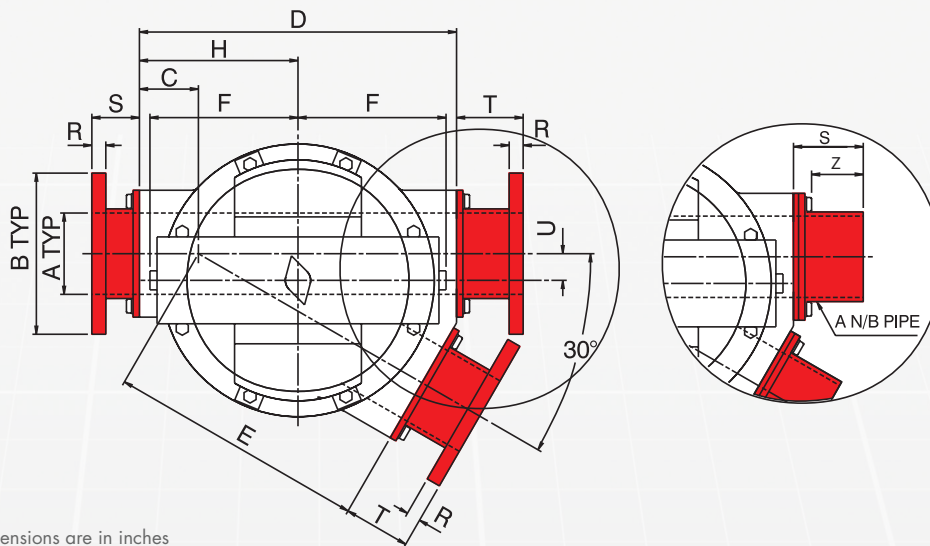

All dimensions are in inches

COMMON MEASUREMENTS														
SIZE	C	D	E	F	H	M	N	P	Q	U	V	W	X	Y
3"	3 1/4"	15 3/8"	12 1/8"	9 1/4"	7 11/16"	8 1/4"	16 5/8"	9 1/4"	5 3/16"	1 3/16"	6 1/4"	3 1/8"	5 7/8"	6 1/2"
4"	3 3/8"	17 5/16"	14"	9 1/4"	8 5/8"	8 5/8"	16 3/4"	9 5/8"	6 1/4"	1 3/8"	6 1/4"	3 1/8"	7 1/8"	6 7/8"
5"	3 5/8"	19 11/16"	16"	9 13/16"	10"	9 1/8"	17 1/4"	10 1/8"	7 9/16"	1 5/8"	6 1/4"	3 1/8"	8 1/2"	7 3/8"
6"	3 11/16"	21 3/8"	17 5/8"	9 1/4"	10 11/16"	10 5/16"	18 1/2"	11 3/8"	8 1/16"	1 7/8"	6 1/4"	3 1/8"	9"	8 1/2"
8"	4 5/8"	26 3/8"	21 3/4"	9 1/4"	13 3/16"	11 1/2"	19 5/8"	12 1/2"	10"	2 5/16"	6 1/4"	3 1/8"	11"	9 5/8"
10"	5 9/16"	31 1/2"	25 15/16"	9 1/4"	15 3/4"	12 5/8"	20 3/4"	22 1/2"	12"	2 3/4"	12"	12"	13"	12 5/8"

FLANGE ASA									SPIGOTTED			
SIZE	ØA	ØB	J	ØK	L	R	S	T	SIZE	A Pipe	Z	S
3"	3 1/16"	7 1/2"	4	3/4"	6"	11/16"	3 1/8"	3 1/8"	3"	3"	3 3/8"	4 5/16"
4"	4"	9"	8	3/4"	7 1/2"	11/16"	2 3/4"	4 1/8"	4"	4"	3 3/16"	4 5/16"
5"	5"	10"	8	7/8"	8 1/2"	11/16"	3"	4 1/8"	5"	5"	3 3/16"	4 5/16"
6"	6"	11"	8	7/8"	9 1/2"	11/16"	3"	3 13/16"	6"	6"	3 3/16"	4 5/16"
8"	8"	13 1/2"	8	7/8"	11 3/4"	11/16"	3 1/8"	5 1/8"	8"	8"	3 1/8"	4 5/16"
10"	10"	16"	12	1"	14 1/4"	1 1/8"	3 9/16"	5 9/16"	10"	10"	3 1/8"	4 5/16"

Dimensions are approximate and subject to change without notice
Planning-in detail for general guidance only
(To cover safety aspects ask for our safety leaflets)
Drillings are Rotolok standards. Variations can be made.



www.ROTOLOK.us

OTHER ROTOLOK PRODUCTS

As well as the Plug Diverter Valves, Rotolok manufacture and supply a range of other products in Cast Iron for use in conveying systems.

These include, but are not limited to: Slide Gates with Pneumatic, Motorised or Manual operation; Rotary Valve; Dust Collector Valve; Roundhead Valve; Blowing Seals and Offset Rotary Valves.

For more information, please visit our website or contact our sales team.

A Standard Rotary Valve that can be made to suit most applications with a variety of construction materials and rotors



A Cast Iron conveying diverter valve. Available with flanged or spigotted connections to fit existing conveying systems

A typical Blowing Seal with a square inlet used in pneumatic conveying systems.

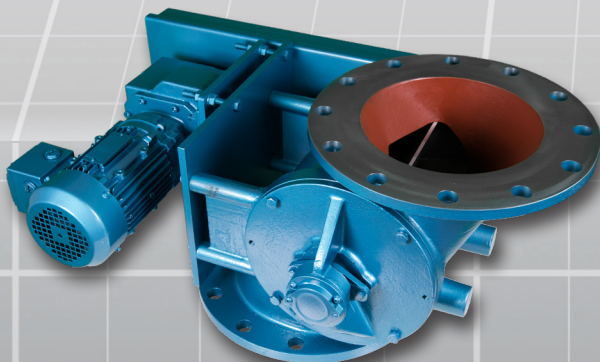
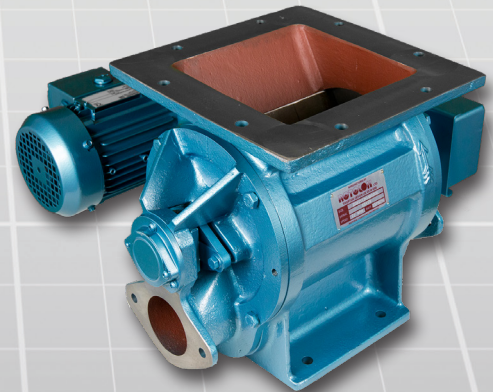

Offset Rotary Valves are designed to feed a product similar to a Standard Rotary Valve but with reduced shearing and damage to the product passing through

Dimensions are approximate and subject to change without notice
Planning-in detail for general guidance only
(To cover safety aspects ask for our safety leaflets)
Drillings are Rotolok standards. Variations can be made.

