

GAS FORM-C
based on the
OCIMF / SIGTTO
SHIP INFORMATION QUESTIONNAIRE
for
GAS CARRIERS
2nd Edition 1998

Specifications of the vessel and the gas installations are believed
to be correct, but not guaranteed.

INDEX

		PAGE
GENERAL INFORMATION		
A1	Principal Ship Particulars	2-3
A2	Hull Dimensions	4
A3	Immersion	4
A4	Loaded Particulars	4-5
A5	Parallel Mid-Body Dimensions	6
A6	Bunker Specifications and Capacities	6
A7	Fuel Consumption Details	6
A7	Speed/Consumption (Appendix)	7
A8	Main Engine Particulars	7
A9	Auxiliary Plants	7
A10	Power/Speed Information	7
A11	Thrusters	7
A12	Fresh Water	7
A13	Ballast Capacities and Pumps	8
A14	Mooring Equipment	8-10
A15	Navigational Equipment	10-11
A16	Communication and Electronics	11
CARGO SYSTEMS		
B1	Cargo - General Information	12
B2	Cargo Tanks	12
B3	Cargo Tank Capacities	13-15
B16	Deck Tank Capacities	15-16
B4	Loading Rates	16-17
B5	Discharging - General	17-18
B6	Discharge Performance	18
B7	Unpumpables	18
B8	Vaporising Unpumpables	18
B9	Reliquefaction Plant	18-19
B10	Section not in use.	
B11	Cargo Temperature Lowering Capability	19
B12	Inert Gas and Nitrogen	19-20
B13	Cargo Tank Inerting / De-Inerting	20
B14	Gas Freeing to Fresh Air	20
B15	Changing Cargo Grades	20-21
B17	Pre-Loading Cooldown	21-22
B18	Vaporiser	22
B19	Blower	22
B20	Cargo Re-Heater	22
B21	Hydrate Control	22
B22	Cargo Measurement	22-23
B23	Cargo Sampling	23
B24	Cargo Manifold	24-25
B25	Cargo Manifold Reducers	25-26
B26	Connections to Shore for ESD and Communication Systems	26
B27	Manifold Derrick/Crane	26
B28	Stores Derrick/Crane	
B29	Sister Vessel(s)	

SECTION A
GENERAL INFORMATION

A1 PRINCIPAL SHIP PARTICULARS

1,1	Date questionnaire completed	
1,2	Name of vessel	JS Jaguar
1,3	LR/IMO number	9578024
1,4	Last previous name	Not applicable
1.4.1	Date of name change	Not applicable
1,5	Second last previous name	Not applicable
1.5.1	Date of name change	Not applicable
1,6	Third last previous name	Not applicable
1.6.1	Date of name change	Not applicable
1,7	Fourth last previous name	Not applicable
1.7.1	Date of name change	Not applicable
1,8	Flag	Singapore
1,9	Port of Registry	Singapore
1.10	Official number	397837
1,11	Call sign	9V9996
1,12	INMARSAT A or B number	Not applicable
1,13	Vessel's telephone number	0047 23673671
1.13.1	Vessel's mobile number	+49 175-2229100
1,14	Vessel's fax number	+870-783168159
1,15	Vessel's telex number	456666011
1,16	Vessel's E-mail address	jsjaguar@les-raisting.de
1,17	INMARSAT C number	00870-773187692
1,18	Vessel's MMSI number	566679000
1,19	Type of vessel	GAS

OWNERSHIP AND OPERATION

1.20	Registered Owner	Marina Mars Shipping Pte Ltd
	Full address	#27-01 Marina Bay Financial Centre – Tower 1 Singapore 018981
	Office telephone number	+49-491-92 88 0
	Office telex number	Not applicable
	Office fax number	+49-491-9288 201
	Office Email address	inspection-tanker@hartmann-reederei.de
	Contact person	Capt. Ulrich Adami
	Contact person after hours telephone number	+49-171-4705844
1.21	Name of technical operator (If different from above)	Hartmann Gas Carriers Germany GmbH & Co. KG
	Full Address	Koenigstrasse 23, 26789 Leer / Germany
	Office telephone number	+49-491-9288 0
	Office telex number	Not applicable
	Office fax number	+49-491-9288 201
	Office Email address	inspection-tanker@hartmann-reederei.de
	Contact person (Designated Person Ashore)	Gerold Poelmann
	Contact person after hours telephone number	+49-171-4821588
	Emergency callout number	+49-421-536870
	Emergency callout pager number	Not applicable
	Contact details for person responsible for oil spill response	ECM, Tel. +1 203 761 6030, +1 281 335 9210, Fax. +1 203 761 6085, +1 281 335 9211
	Number of years controlled by technical operator	

1.22	Total number of ships operated by this Operator	36
1.23	Number of years ship owned	3 Year

1.23.1	Name of commercial operator (If different from above)	Evergas
	Full Address	Kalvebod Brygge 39-41 1560 Copenhagen Denmark
	Office telephone number	+ 45 3997 0372
	Office telex number	N/A
	Office fax number	N/A
	Office Email address	operation@evergas.net
	Contact person	Nete Egebjerg
	Contact person after hours telephone number	+45 3038 1156
	Emergency callout number	+45 3997 0101
	Emergency callout pager number	N/A
	Number of years controlled by commercial operator	0

BUILDER

1.24	Builder	Sinopacific Offshore & Engineering, Nantong, China
1.25	Name of yard vessel built at	SOE
1.26	Hull number (Class ID No.)	DJ1004
1.27	Date keel laid	15-Nov-11
1.28	Date launched	9-Mar-12
1.29	Date delivered	21-sep-12
1.30	Date of completion of major hull changes, - if any.	Not applicable
1.31	If changes were made, what changes were made and at which yard were they carried out	Not applicable

CLASSIFICATION

1.32	Classification society	Bureau Veritas
1.33	Class Notation	Liquefied gas carrier; FLS tanker Unrestricted navigation AUT-UMS , SYS-NEQ , BWE , CLEANSHIP, INWATERSURVEY
1.34	If Classification society changed, name of previous society	DNV-GL
1.35	If Classification society changed, date of change	06-07-2016
1.36	Was ship built in accordance with the following regulations:	

IMO	YES	YES
US COAST GUARD	YES	YES
IACS Class	YES	YES
Other: _____		

1.37	IMO certification	
	Certificate of fitness - IGC	YES
	Certificate - A328	
	Certificate - A329	
	Letter of Compliance	
	Issued by	
1.38	Unattended Machinery Space Certificate	YES

1.39	Net Registered Tonnage	1.511
1.40	Gross Registered Tonnage	5.036
1.41	Suez Net Tonnage - Canal Tonnage	4.447,00
	Suez Gross Tonnage	5.036,00
1.42	Panama Net Tonnage - Canal Tonnage	4.319
	Panama Gross Tonnage	6.054

A2 HULL DIMENSIONS

2.1	Length overall (LOA)	99,85	Metres
2.2	Length between perpendiculars (LBP)	92,50	Metres
2.3	Distance bow to bridge	80,00	Metres
2.4	Distance bridge front - mid point manifold	27,60	Metres
2.5	Distance bow to mid-point manifold	44,90	Metres
2.6	Extreme breadth	17,40	Metres
2.7	Extreme depth	11,70	Metres
2.8	Summer draught (design / Scantling)	7,06	Metres
2.9	Corresponding Summer deadweight	4994,0	Tonnes
2.10	Light displacement	3426,0	Tonnes
2.11	Loaded displacement (Summer deadweight)	8420,0	Tonnes
2.12	Cargo tanks cubic capacity - 100%	5036,59	Cubic metres
2.12.1	Deck tank(s) cubic capacity - 100%	NA	Cubic metres
2.12.2	Cargo tanks cubic capacity - 98%	4935,86	Cubic metres
2.12.3	Deck tank(s) cubic capacity - 98%	NA	Cubic metres
2.13	Distance from keel to highest point	32,45	Metres
2.14	Air draught (normal ballast condition)	27,50	Metres

A3 IMMERSION

- 3.1 TPC - in normal ballast condition
 TPC - in loaded condition (summer deadweight)

Tonnes / cm @ metres draught	
13	4,8
14,5	7,06

A4 LOADED PARTICULARS

	N-Butane	C-Propane	
4.1	Cargo grade	0,579	Tonnes/m3
4.2	Density	2,858	Tonnes
4.3	Cargo loadable	665,9	Tonnes
4.4	Bunkers - FO	145,7	Tonnes
4.5	Bunkers - DO	218,6	Tonnes
4.6	Fresh water	31,4	Tonnes
4.7	Stores & spares	17,9	Tonnes
4.8	Lub oil	1100	Tonnes
4.9	Ballast	4150	Tonnes
4.10	Deadweight	6,35	Metres
4.11	Draught - forward	6,55	Metres
	Draught - aft	6,45	Metres
	Draught - mean	6,51	Metres

	Butadiene	Propylene	
	0,622	0,5131	Tonnes/m3
	3070	2394	Tonnes
	665,9	665,9	Tonnes
	145,7	145,7	Tonnes
	218,6	218,6	Tonnes
	31,4	31,4	Tonnes
	17,9	17,9	Tonnes
	350	1023	Tonnes
	4480	4551	Tonnes
	6,53	6,68	Metres
	6,7	6,81	Metres
	6,62	6,75	Metres

	Ethylene	Ammonia	
Cargo grade	NA	NA	Tonnes/m3
Density	NA	NA	Tonnes
Cargo loadable	NA	NA	Tonnes
Bunkers - FO / LNG	NA	NA	Tonnes
Bunkers - DO	NA	NA	Tonnes
Fresh water	NA	NA	Tonnes
Stores & spares	NA	NA	Tonnes
Lub oil	NA	NA	Tonnes
Ballast	NA	NA	Tonnes
Deadweight	NA	NA	Tonnes
Draught - forward	NA	NA	Metres
Draught - aft	NA	NA	Metres
Draught - mean	NA	NA	Metres

	VCM	Propylene Oxide	
Cargo grade	0,9123		Tonnes/m3
Density	4281		Tonnes
Cargo loadable	340,4		Tonnes
Bunkers - FO	74,3		Tonnes
Bunkers - DO	109,3		Tonnes
Fresh water	31,4		Tonnes
Stores & spares	17,9		Tonnes
Lub oil	201,4		Tonnes
Ballast	5099		Tonnes
Deadweight	6,27		Metres
Draught - forward	7,85		Metres
Draught - aft	7,06		Metres
Draught - mean			

	Ballast		
Cargo grade	1.025		Tonnes/m3
Density	0		Tonnes
Cargo loadable	665,9		Tonnes
Bunkers - FO	145,7		Tonnes
Bunkers - DO	218,6		Tonnes
Fresh water	31,4		Tonnes
Stores & spares	17,9		Tonnes
Lub oil	1977,6		Tonnes
Ballast	3111		Tonnes
Deadweight	5,48		Metres
Draught - forward	5,95		Metres
Draught - aft	5,71		Metres
Draught - mean			

A5 PARALLEL MID-BODY DIMENSIONS

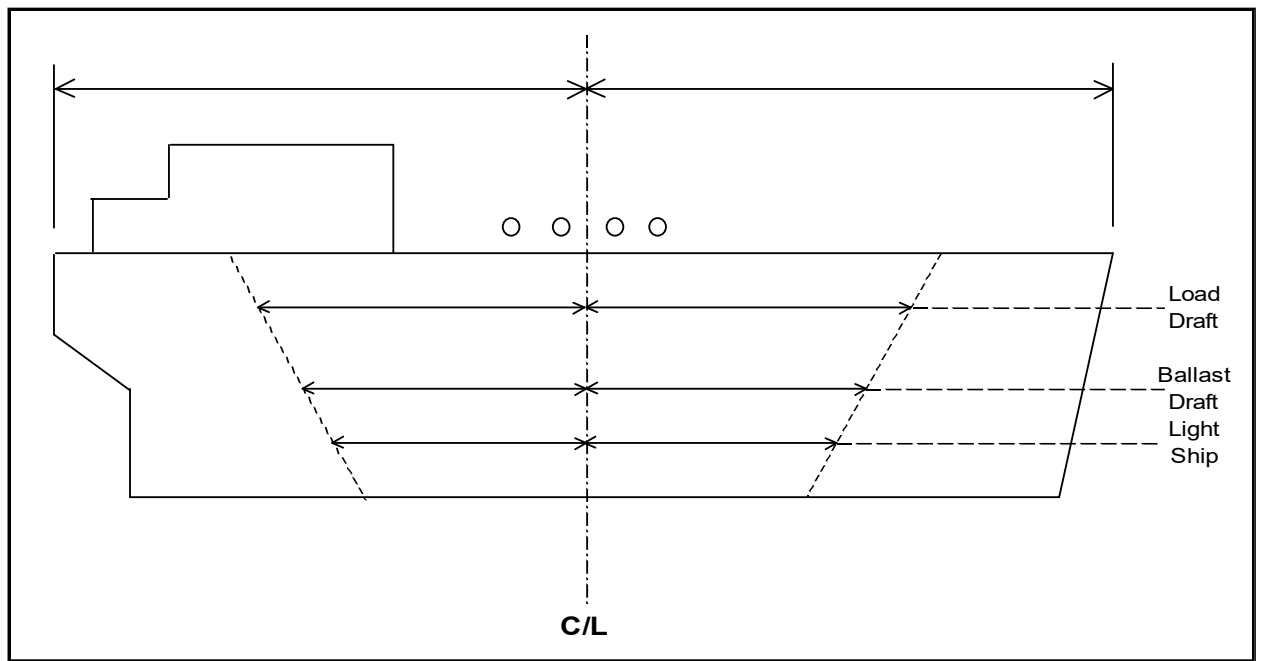

5.1	Light ship	31,9	Metres
5.2	Forward to mid-point manifold - light ship	5,6	Metres
5.3	Aft to mid-point manifold - light ship	26,3	Metres
5.4	Normal ballast	42	Metres
5.5	Forward to mid-point manifold - normal ballast	11,8	Metres
5.6	Aft to mid-point manifold - normal ballast	30,2	Metres
5.7	Loaded SDWT	47	Metres
5.8	Forward to mid-point manifold - loaded SDWT	13,7	Metres
5.9	Aft to mid-point manifold - loaded SDWT	33,3	Metres

A6 BUNKER CAPACITIES

Main engine
 Auxiliary engine(s)
 Other: LSDO

Grade	Capacity @ 98%
HFO	570
MDO	138
LSDO	

A7 FUEL CONSUMPTION DETAILS

- 7.1 At sea - normal service speed
- 7.2 At sea - normal service speed - while conditioning cargo full cooling
- 7.3 In port - loading
- 7.4 In port - discharging
- 7.5 In port - idle

Grade		
HFO	10	Tonnes/day
Diesel oil	NA	Tonnes/day
Gas oil	0	Tonnes/day
HFO	10	Tonnes/day
Diesel oil	NA	Tonnes/day
Gas oil	0	Tonnes/day
HFO	0	Tonnes/day
Diesel oil	NA	Tonnes/day
Gas oil	1,5	Tonnes/day
HFO	0	Tonnes/day
Diesel oil	NA	Tonnes/day
Gas oil	2	Tonnes/day
HFO	0	Tonnes/day
Diesel oil	NA	Tonnes/day
Gas oil	1,5	Tonnes/day

A7 SPEED/CONSUMPTION

Copies of the vessel's Speed and Consumption Graph for both Laden and Ballast conditions are enclosed?

--

A8 MAIN ENGINE PARTICULARS

8.1	Main engine make and type	MAN 6L 32/40 CD	
		4 stroke	
8.2	Number of units	1	
8.3	Maximum continuous rating (MRC) per engine	750	3000
8.4	Total available power - Kwe		3.000 kW
8.5	Normal service power - Kwe at 90% SMCR		2.700 kW

A9 AUXILIARY PLANTS

9.1	Make and type of auxiliary generators / engines	VOLVO PENTA D16	
9.2	Number of units	2	
9.3	Maximum generator output per unit	RPM	Kilowatts
	Unit no. 1	1800	425 kW
	Unit no. 2	1800	425 kW
	Unit no. 3		kW
9.4	Shaft generator		400 kW
9.5	Total available power		
9.6	Emergency generator	1800	385 kW
9.7	Emergency fire pump - type	centrifugal pump	
	Delivery pressure		8 bar
	Motive power		
	If electrical, - indicate power required		17,5 kW
9.8	Steering gear - type	rotary screw	
	Indicate power required to steer the vessel with one pump unit		8 kW

A10 POWER/SPEED INFORMATION

10.1	Trial data	BHP	3000	kW
		MRC	2758	kW
		Speed	15,6	KN
		Draught	4,7	M
10.2	Normal service speed (LOADED / BALLAST)	BHP	3000	kW
		MRC	2700	kW
		Speed		KN
		Draught	4,80 / 7,06	M

A11 THRUSTERS

11.1	Make and type	Schottel Tunnel Thruster	
11.2	Bow thruster	(output)	250 kW
11.3	Stern thruster	(output)	NA

A12 FRESH WATER

12.1	Capacity of distilled tanks	NA	Cubic metres
12.2	Capacity of domestic tanks	218,6	Cubic metres
12.3	Daily consumption	Distilled	NA Tonnes
		Domestic	3-4 Tonnes
12.4	Daily evaporator capacity	9	Tonnes

Mooring Ropes (On Drums) Aft Main Deck - Number	4	
Diameter	46	
Material	Poly	
Length	120	
Breaking Strength	44	
Mooring Ropes (On Drums) Poop - Number	NA	
Diameter	NA	MM
Material	NA	
Length	NA	M
Breaking Strength	NA	MT

OTHER MOORING LINES

Mooring Ropes not on Drums - Number	8	
Diameter	52	MM
Material	Poly	
Length	220	M
Breaking Strength	44	MT
Emergency Towing Wires / Fire Wires - Number	NA	
Diameter	NA	MM
Material	NA	
Length	NA	M
Breaking Strength	NA	MT

14,2

MOORING WINCHES

Forecastle - Number	2	
Single Drum or Double Drums	double	
Split Drums Y/N	Yes	
Motive Power	51 kW	
Heaving Power	125 KN	
Brake Capacity	27,9	
Hauling Speed	15 m/min	
Forward Main Deck - Number	NA	
Single Drum or Double Drums	NA	
Split Drums Y/N	NA	
Motive Power	NA	
Heaving Power	NA	
Brake Capacity	NA	
Hauling Speed	NA	
Aft Main Deck - Number	2	
Single Drum or Double Drums	double	
Split Drums Y/N	Yes	
Motive Power	35kW	
Heaving Power	80 KN	
Brake Capacity	27,9	
Hauling Speed	15 m/min	
Poop - Number	NA	
Single Drum or Double Drums	NA	
Split Drums Y/N	NA	
Motive Power	NA	
Heaving Power	NA	mt
Brake Capacity	NA	
Hauling Speed	NA	

14.3

ANCHORS AND WINDLASS

Windlass motive power(e.g. steam, hydraulic)	electric	
Hauling power	125	kN
Brake holding power	700	kN
Anchor type	Spek	
Weight	3120	kg

Is spare anchor carried	NO	
Cable diameter	56	mm
Number of shackles port cable	9	
Number of shackles starboard cable	9	

14.4	TOWING ARRANGEMENTS			
	Is the vessel fitted with a Towing Bracket Aft?		Yes	
		If Yes, state SWL	98	
	Is Towing chain provided		NO	
	Dimensions of Towing wire	Diameter		
		Length		

14.5	WINDAGE			
	Windage on ballast draught	Front		M2
		End-on		M2
		Lateral		M2

A15 NAVIGATIONAL EQUIPMENT

15.1	Magnetic compass		YES	
15.2	Off Course Alarm - Magnetic compass		NO	
15.3	Gyro compass	Number of Units	YES	
			1	
15.4	Off Course Alarm - Gyro compass		YES	
15.5	Gyro (Bridge) Repeaters	Number of Units	YES	
			2	
15.6	Radar 3cm		YES	
15.7	Radar 10cm		YES	
15.8	Are radars gyro stabilised?		YES	
15.9	Radar plotting equipment		YES	
15.10	ARPA		YES	
15.11	ECDIS		YES	
15.12	Depth sounder with recorder		YES	
15.13	Depth sounder without recorder		NO	
15.14	Speed/distance indicator		YES	
15.15	Doppler log		YES	
15.16	Docking approach Doppler		NO	
15.17	Rudder angle indicator		YES	
15.18	Rudder angle indicator on Each Bridge Wing		YES	
15.19	RPM indicator		YES	
15.20	RPM indicator on Each Bridge Wing		YES	
15.21	Controllable pitch propeller indicator		YES	
15.22	Thruster(s) indicator		YES	
15.23	Rate of turn indicator		NO	
15.24	Radio direction finder		NO	
15.25	Navtex receiver		YES	
15.26	GPS		YES	
15.26.1	DGPS		YES	
15.27	Transit SATNAV		NO	
15.28	Decca navigator		NO	
15.29	Omega		NO	
15.30	Loran C		NO	
15.31	Weather fax		YES	
15.32	Sextant(s)		YES	
15.33	Signal lamp ALDIS		YES	
15.34	Anemometer		YES	
15.35	Engine order recorder		YES	
15.35.1	VDR (Voyage Data Recorder)		YES	
15.36	Course recorder		YES	
15.37	Are steering motor controls and engine controls fitted on bridge wings?		YES	

15.38	Is bridge equipped with a 'Dead-Man' alarm?		YES
15.39	What chart outfit coverage is provided	World-wide	YES
		Limited	
		If limited, - please indicate area(s) covered	
15.40	Formal chart correction system in use		Chartco/NTM
15.41	Electronic Chart system in use		YES

A16 COMMUNICATIONS AND ELECTRONICS

16.2	What GMDSS areas is the vessel classed for? A1 A2 A3 A4		A1, A2, A3
16.3	Transponder (SART)		YES
16.4	EPIRB		YES
16.5	How many VHF radios are fitted on the bridge?		2
16.6	Is vessel fitted with VHF in the cargo control room (CCR)?		YES
16.7	Is the CCR connected to the vessel's internal communication system?		YES
16.8	How many intrinsically safe walkie talkies are provided for cargo handling?		8
16.9	Is vessel fitted with an INMARSAT satellite communications system?		YES
16.10	Does vessel carry at least three survival craft two-way radio telephones?		YES
16.11	Inmarsat satellite system		YES
		Specify system type A, B or C	C
16.12	2182kHz bridge auto alarm		YES
16.13	Radio telephone distress frequency watch receiver		YES
16.14	Emergency lifeboat transceiver		NO
16.15	Can vessel transmit the helicopter homing signal on 410 kHz?		NO
16.16	Full set of Radio List publications		YES

**SECTION B
CARGO SYSTEMS**

B1 CARGO - GENERAL INFORMATION

1.1 List products which the ship is Certified to carry

Cargo	Temp at atm. Press (Celcius)	Density at atm. Press (kg/m3)
Ethylene		
Ethane		
Propylene	-48	609
Propane (pure)	-42	581
C-Propane (2,5 mol% ethane in Liq. Phase)	-45	583
Mix of propane and butane		
Anhydrous Ammonia		
VCM	-14	969
Iso-Butane	-12	594
Butylenes (data for Iso)	-7	625
Butadiene	-5	650
N-Butane	0	602
DME		
Other Cargoes		
Acetaldehyde		
Dimethyl Amine		
Ethyl Chloride		
Diethyl Ether		
Isoprene (Monomer)	34	666
Isopropyl Amine	32	676
Monoethyl Amine		
N-Pentane / 1-Pentene		
Propylene Oxide (PO)	34	817
Vinyl Ethyl Ether		

Transport and Carriage Conditions

1.2	Minimum allowable tank temperature	-10	Deg. Celsius
1.3	Maximum Permissible tank pressure	18,6	Bar gauge
1.4	List Number of grades that can be loaded/discharged simultaneously and completely segregated without risk of contamination?	2	
1.5	List the Number of grades that can be carried simultaneously and completely segregated without risk of contamination?	2	
1.6	What is the Number of Products that can be conditioned by reliquefaction simultaneously?	NA	
1.7	State the number of natural segregation's (NB: Separation must be by the removal of spools or the insertion of blanks)	2	

B2 CARGO TANKS

2.1	Type and materials of cargo tanks	Type C / High Tensile Carbon Steel TSTE690	
2.2	Maximum allowable relief valve setting	18,6	Bar gauge
2.2.1	IMO Setting	18,6	Bar gauge
2.2.2	USCG Setting	NA	Bar gauge
2.3	Safety valve set pressure, - if variable stipulate range of pilot valves		Bar gauge
2.4	Maximum allowable vacuum	0,7	Bar gauge
2.5	Maximum cargo density at 15 deg Celsius	956	Kg/m3
2.6	Maximum rate of cool-down	NA	Deg Cel / Hour
2.7	State any limitations regarding partially filled tanks		

Bilobe Tank max level difference 30 cm

--

2.8

State allowable combinations of filled and empty tanks

B3 CARGO TANK CAPACITIES

Tank number / location

Capacity m3 (100%)
 Capacity 98%
 N-Butane capacity 98%
 N-Butane temperature
 C-Propane capacity 98%
 C-Propane temperature
 Butadiene capacity
 Butadiene temperature
 Propylene capacity
 Propylene temperature
 Vinyl Chloride Monomer capacity
 Vinyl Chloride Monomer temperature
 Ethylene capacity
 Ethylene temperature
 Propylene Oxide capacity
 Propylene Oxide temperature
 Ammonia capacity
 Ammonia temperature

CT 1	
1787,31	m3
1751,56	m3
1014,00	Tonnes
20	Deg. C
879,00	Tonnes
20	Deg. C
1089,00	Tonnes
20	Deg. C
898,00	Tonnes
20	Deg. C
1597,00	Tonnes
20	Deg. C
NA	Tonnes
NA	Deg. C
1453,00	Tonnes
20	Deg. C
NA	Tonnes
NA	Deg. C

Tank number / location

Capacity m3 (100%)
 Capacity 98%
 N-Butane capacity 98%
 N-Butane temperature
 C-Propane capacity 98%
 C-Propane temperature
 Butadiene capacity
 Butadiene temperature
 Propylene capacity
 Propylene temperature
 Vinyl Chloride Monomer capacity
 Vinyl Chloride Monomer temperature
 Ethylene capacity
 Ethylene temperature
 Propylene Oxide capacity
 Propylene Oxide temperature
 Ammonia capacity
 Ammonia temperature

CT 2 P&S bilobe	
3249,280	m3
3184,290	m3
1843,00	Tonnes
20	Deg. C
1598,00	Tonnes
20	Deg. C
1980,00	Tonnes
20	Deg. C
1633,00	Tonnes
20	Deg. C
2904,00	Tonnes
20	Deg. C
NA	Tonnes
NA	Deg. C
2642,00	Tonnes
20	Deg. C
NA	Tonnes
NA	Deg. C

Tank number / location

Capacity m3 (100%)
 Capacity 98%
 N-Butane capacity 98%
 N-Butane temperature
 C-Propane capacity 98%
 C-Propane temperature
 Butadiene capacity
 Butadiene temperature
 Propylene capacity
 Propylene temperature
 Vinyl Chloride Monomer capacity
 Vinyl Chloride Monomer temperature
 Ethylene capacity

NA	
	m3
	m3
	Tonnes
	Deg. C
	Tonnes
	Deg. C
	Tonnes
	Deg. C
	Tonnes
	Deg. C
	Tonnes
	Deg. C
	Tonnes

Ethylene temperature		Deg. C
Propylene Oxide capacity		Tonnes
Propylene Oxide temperature		Deg. C
Ammonia capacity		Tonnes
Ammonia temperature		Deg. C

Tank number / location

Capacity m3 (100%)	N/A	m3
Capacity 98%		m3
Butane capacity		Tonnes
Butane temperature		Deg. C
Propane capacity		Tonnes
Propane temperature		Deg. C
Butadiene capacity		Tonnes
Butadiene temperature		Deg. C
Propylene capacity		Tonnes
Propylene temperature		Deg. C
Vinyl Chloride Monomer capacity		Tonnes
Vinyl Chloride Monomer temperature		Deg. C
Ethylene capacity		Tonnes
Ethylene temperature		Deg. C
Propylene Oxide capacity		Tonnes
Propylene Oxide temperature		Deg. C
Ammonia capacity		Tonnes
Ammonia temperature		Deg. C

Tank number / location

Capacity m3 (100%)	N/A	m3
Capacity 98%		m3
Butane capacity		Tonnes
Butane temperature		Deg. C
Propane capacity		Tonnes
Propane temperature		Deg. C
Butadiene capacity		Tonnes
Butadiene temperature		Deg. C
Propylene capacity		Tonnes
Propylene temperature		Deg. C
Vinyl Chloride Monomer capacity		Tonnes
Vinyl Chloride Monomer temperature		Deg. C
Ethylene capacity		Tonnes
Ethylene temperature		Deg. C
Propylene Oxide capacity		Tonnes
Propylene Oxide temperature		Deg. C
Ammonia capacity		Tonnes
Ammonia temperature		Deg. C

Tank number / location

Capacity m3 (100%)	N/A	m3
Capacity 98%		m3
Butane capacity		Tonnes
Butane temperature		Deg. C
Propane capacity		Tonnes
Propane temperature		Deg. C
Butadiene capacity		Tonnes
Butadiene temperature		Deg. C
Propylene capacity		Tonnes
Propylene temperature		Deg. C
Vinyl Chloride Monomer capacity		Tonnes
Vinyl Chloride Monomer temperature		Deg. C
Ethylene capacity		Tonnes
Ethylene temperature		Deg. C
Propylene Oxide capacity		Tonnes

Propylene Oxide temperature		Deg. C
Ammonia capacity		Tonnes
Ammonia temperature		Deg. C

Tank number / location

	N/A	
Capacity m3 (100%)		m3
Capacity 98%		m3
Butane capacity		Tonnes
Butane temperature		Deg. C
Propane capacity		Tonnes
Propane temperature		Deg. C
Butadiene capacity		Tonnes
Butadiene temperature		Deg. C
Propylene capacity		Tonnes
Propylene temperature		Deg. C
Vinyl Chloride Monomer capacity		Tonnes
Vinyl Chloride Monomer temperature		Deg. C
Ethylene capacity		Tonnes
Ethylene temperature		Deg. C
Propylene Oxide capacity		Tonnes
Propylene Oxide temperature		Deg. C
Ammonia capacity		Tonnes
Ammonia temperature		Deg. C

Tank number / location

	N/A	
Capacity m3 (100%)		m3
Capacity 98%		m3
Butane capacity		Tonnes
Butane temperature		Deg. C
Propane capacity		Tonnes
Propane temperature		Deg. C
Butadiene capacity		Tonnes
Butadiene temperature		Deg. C
Propylene capacity		Tonnes
Propylene temperature		Deg. C
Vinyl Chloride Monomer capacity		Tonnes
Vinyl Chloride Monomer temperature		Deg. C
Ethylene capacity		Tonnes
Ethylene temperature		Deg. C
Propylene Oxide capacity		Tonnes
Propylene Oxide temperature		Deg. C
Ammonia capacity		Tonnes
Ammonia temperature		Deg. C

Total Capacity of all cargo tanks (100%)		m3
Total Capacity of all cargo tanks (98%)		m3
Total Capacity of N-Butane		Tonnes
Total Capacity of C-Propane		Tonnes
Total Capacity of Butadiene		Tonnes
Total Capacity of Propylene		Tonnes
Total Capacity of Vinyl Chloride Monomer		Tonnes
Total Capacity of Ethylene		Tonnes
Total Capacity of Propylene Oxide		Tonnes
Total Capacity of Ammonia		Tonnes

B16 DECK TANK CAPACITIES

Are Deck pressure tank(s) fitted?	NA	
Material of tank(s)	NA	
Maximum allowable relief valve setting	NA	Bar gauge

Deck tank number 1 - capacity (100%)

Capacity 98%
 Propane Capacity
 Butane Capacity
 Propylene capacity
 Ethylene capacity
 Ammonia Capacity

NA	m3
NA	m3
NA	Tonnes
NA	Tonnes
NA	Tonnes
NA	Tonnes
NA	Tonnes

Deck tank number 2 - capacity (100%)

Capacity 98%
 Propane Capacity
 Butane Capacity
 Propylene capacity
 Ethylene capacity
 Ammonia Capacity

NA	m3
NA	m3
NA	Tonnes
NA	Tonnes
NA	Tonnes
NA	Tonnes
NA	Tonnes

B4 LOADING RATES**4.1 From Refrigerated Storage (Fully Refrigerated at Vessel's Manifold)**

N-Butane - with vapour return
 N-Butane - without vapour return
 C-Propane - with vapour return
 C-Propane - without vapour return
 Butadiene - with vapour return
 Butadiene - without vapour return
 Propylene - with vapour return
 Propylene - without vapour return
 Ethylene - with vapour return
 Ethylene - without vapour return **)
 Ammonia - with vapour return
 Ammonia - without vapour return
 Vinyl Chloride Monomer - with vapour return
 Vinyl Chloride Monomer - without vapour return
 Propylene Oxide - with vapour return
 Propylene Oxide - without vapour return

450	cbm/hr
450	cbm/hr
200	cbm/hr
200	cbm/hr
450	cbm/hr
450	cbm/hr
NA	cbm/hr
NA	cbm/hr
NA	cbm/hr
NA	cbm/hr
NA	cbm/hr
200	cbm/hr
200	cbm/hr
450	cbm/hr
NA	cbm/hr

4.8 From Pressure Storage

N-Butane 0 deg C - with vapour return
 0 deg C - without vapour return
 10 deg C - with vapour return
 10 deg C - without vapour return
 20 deg C - with vapour return
 20 deg C - without vapour return

450	cbm/hr
450	cbm/hr
450	cbm/hr
450	cbm/hr
450	cbm/hr
450	cbm/hr

C-Propane minus 30 deg C - with vapour return

Minus 30 deg C - without vapour return
 Minus 20 deg C - with vapour return
 Minus 20 deg C - without vapour return
 Minus 10 deg C - with vapour return
 Minus 10 deg C - without vapour return
 0 deg C - with vapour return
 0 deg C - without vapour return
 10 deg C - with vapour return by compressors
 10 deg C - without vapour return
 20 deg C - with vapour return by compressors
 20 deg C - without vapour return

NA	Tonnes/hour
NA	Tonnes/hour
NA	Tonnes/hour
NA	Tonnes/hour
200	Tonnes/hour
200	Tonnes/hour
200	Tonnes/hour
200	Tonnes/hour
200	Tonnes/hour
200	Tonnes/hour
200	Tonnes/hour
200	Tonnes/hour
200	Tonnes/hour

Butadiene 0 deg C - with vapour return	450	Tonnes/Hr.
0 deg C - without vapour return	450	Tonnes/Hr.
10 deg C - with vapour return	450	Tonnes/Hr.
10 deg C - without vapour return	450	Tonnes/Hr.
20 deg C - with vapour return	450	Tonnes/Hr.
20 deg C - without vapour return	450	Tonnes/Hr.

Propylene minus 30 deg C - with vapour return	NA	Tonnes/Hr.
Minus 30 deg C - without vapour return	NA	Tonnes/Hr.
Minus 20 deg C - with vapour return	NA	Tonnes/Hr.
Minus 20 deg C - without vapour return	NA	Tonnes/Hr.
Minus 10 deg C - with vapour return	NA	Tonnes/Hr.
Minus 10 deg C - without vapour return	NA	Tonnes/Hr.
0 deg C - with vapour return	NA	Tonnes/Hr.
0 deg C - without vapour return	NA	Tonnes/Hr.
10 deg C - with vapour return by compressors	NA	Tonnes/Hr.
10 deg C - without vapour return	NA	Tonnes/Hr.
20 deg C - with vapour return by compressors	NA	Tonnes/Hr.
20 deg C - without vapour return	NA	Tonnes/Hr.

Ethylene minus 100 deg C - with vapour return	NA	Tonnes/Hr.
Minus 100 deg C - without vapour return **)	NA	Tonnes/Hr.
Minus 95 deg C - with vapour return	NA	Tonnes/Hr.
Minus 95 deg C - without vapour return **)	NA	Tonnes/Hr.
Minus 90 deg C - with vapour return	NA	Tonnes/Hr.
Minus 90 deg C - without vapour return **)	NA	Tonnes/Hr.
Minus 85 deg C - with vapour return	NA	Tonnes/Hr.
Minus 85 deg C - without vapour return **)	NA	Tonnes/Hr.

Butadiene 0 deg C - with vapour return	450	Tonnes/Hr.
0 deg C - without vapour return	450	Tonnes/Hr.
10 deg C - with vapour return	450	Tonnes/Hr.
10 deg C - without vapour return	450	Tonnes/Hr.
20 deg C - with vapour return	450	Tonnes/Hr.
20 deg C - without vapour return	450	Tonnes/Hr.

VCM minus 10 deg C - with vapour return	200	Tonnes/Hr.
Minus 10 deg C - without vapour return	200	Tonnes/Hr.
0 deg C - with vapour return	200	Tonnes/Hr.
0 deg C - without vapour return	200	Tonnes/Hr.
10 deg C - with vapour return	200	Tonnes/Hr.
10 deg C - without vapour return	200	Tonnes/Hr.
20 deg C - with vapour return	200	Tonnes/Hr.
20 deg C - without vapour return	200	Tonnes/Hr.

4.14

Special remarks:

fully ref cargo to be warmed up
min loading temp @ manifold -10 DegC

B5 DISCHARGING - GENERAL

Cargo Pumps

5.1	Type of Pumps	Svanehoj deepwell pumps	
5.2	Number of pumps per tank	1	
5.3	Rate per Pump	200	m3/hr
5.4	At Delivery Head m/c	120	m/c
5.5	Maximum density	956	Kg/m3

Booster Pump

- 5.6 Type of Booster Pumps
- 5.7 Number of pumps
- 5.8 Rate per Pump
- 5.9 At Delivery Head m/c
- 5.10 Maximum density

NA	
	m3/hr
	m/c
	kg/m3

Copies of pumping curves for cargo and booster pumps are enclosed?

no

B6 DISCHARGE PERFORMANCE

Full Cargo Discharge Times per tank (using 2 cargo pumps and 1 booster pump)

Fully Refrigerated

- Manifold Back Press 1 kP/cm2, with vapour return
- Manifold Back Press 1 kP/cm2, without vapour return
- Manifold Back Press 5 bar g - Ammonia - DW pump
- Manifold Back Press 5 bar g - C-Propane - DW pump
- Manifold Back Press 10 kP/cm2, with vapour return
- Manifold Back Press 10 kP/cm2, without vapour return

12,5	Hours
12,5	
12,5	Hours
12,5	Hours
12,5	Hours
12,5	Hours
12,5	Hours

Pressurised

- Manifold Back Press 1 kP/cm2, with vapour return
- Manifold Back Press 1 kP/cm2, without vapour return
- Manifold Back Press 5 bar g - Ammonia 0.9 bar g - DW pump
- Manifold Back Press 5 kg/cm2, without vapour return
- Manifold Back Press 10 bar g - C-Propane 4.8 bar g - DW pump
- Manifold Back Press 10 bar g - Ammonia 0.9 bar g - DW pump

12,5	Hours
12,5	Hours
NA	Hours
NA	Hours
NA	Hours
NA	Hours

B7 UNPUMPABLES

- 7.1 Tank number / location
- Tank number / location
- Tank number / location
- Tank number / location
- Tank number / location
- Tank number / location
- Tank number / location
- Tank number / location
- Tank number / location
- Total

1	0	m3
2 P	0	m3
2 STB	0	m3
		m3
		m3
		m3
		m3
		m3
		m3

B8 VAPORISING UNPUMPABLES

- 8.1 Process used
- Time to vaporise liquid unpumpables remaining after full cargo discharge of (1 CT, 1 Compressor running):

NA

- 8.2 Butane
- 8.3 Propane
- 8.4 Butadiene
- 8.5 Propylene
- 8.6 Ethylene
- 8.7 Ammonia
- 8.8 Vinyl Chloride Monomer
- 8.9 Propylene Oxide

NA	Hours
NA	Hours
NA	Hours
NA	Hours
NA	Hours
NA	Hours
NA	Hours
NA	Hours

B9 RELIQUEFACTION PLANT

- 9.1 Plant Design Conditions - air temperature

45	Deg. C
----	--------

9.3 Plant Design Conditions - sea temperature

32

 Deg. C

Plant Type

9.4 Is the plant single stage/direct? (for warm cargoes):

single

9.5 Is the plant two stage/direct? (for propane, propylene and ammonia):

NA

9.6 Is the plant simple cascade?

NA

9.7 Coolant type

NA

Compressors

9.8 Compressor type

Piston Compressor

9.8.1 Compressor makers name

KöHö TWE 8.11

9.9 Number of compressors

1

9.10 Capacity per unit, 1st / 2nd stage (swept volume)

270-330

 m3/hr

9.11 Are they Oil Free?

YES

B11 CARGO TEMPERATURE LOWERING CAPABILITY (AT SEA WITH SEA TEMPERATURE +15C)

Time taken to lower the temperature of:

11.1 **C-Propane from -5 deg C to -42 deg C**

NA

 Hours

11.2 **C-Propane from -20 deg C to -42 deg C**

NA

 Hours

11.3 **C-Propane from -38 deg C to -42 deg C**

NA

 Hours

11.4 **C-Propane from +20 deg C to -0.50 deg C**

NA

 Hours

11.5 **C-Propane from 0 deg C to -20 deg C**

NA

 Hours

11.6 **N-Butane from +20 deg C to -0.5 deg C**

NA

 Hours

11.7 **N-Butane from +10 deg C to -0.5 deg C**

NA

 Hours

11.8 **N-Butane from +10 deg C to -5 deg C**

NA

 Hours

11.9 **Butadiene**
From +20 deg C to -5 deg C

NA

 Hours

11.10 **Propylene**
From -20 deg C to -47 deg C

NA

 Hours

11.11 **Ethylene**
From -99 deg C to -103 deg C

NA

 Hours

11.12 **Ammonia**
From -16 deg C to -33 deg C

NA

 Hours

11.13 **Vinyl Chloride Monomer**
From -5 deg C to -14 deg C

NA

 Hours

B12 INERT GAS AND NITROGEN

Main IG Plant

12.1 Type of system

NA

12.2 Capacity

NA

12.3 Type of fuel used

NA

12.4 Composition of IG - oxygen

NA

Composition of IG - CO2

NA

Composition of IG - Nox

NA

Composition of IG - N2

NA

12.5 Lowest dewpoint achievable

NA

12.6 Used for

NA

Nitrogen plant

12.7 Type of System

PSA

12.8 Purity N2

99.8%

12.9 Capacity

200 cbm/hr

Purity N2

NA

Capacity

NA

12.10	Purity N2	NA
12.10	Capacity	NA
12.11	Used for	Grade change

Nitrogen

12.12	Liquid storage capacity	NA	LTR
12.13	Daily boil-off loss	NA	
12.14	Maximum supply pressure	NA	Bar
12.15	Supply capacity	NA	
12.16	Used for	NA	

B13 CARGO TANK INERTING/DE-INERTING

13.1	Time taken to inert from fresh air to under 5% O2 at minus 25 degree C?	30	Hours
13.2	Time taken to inert from cargo vapour to fully inert at minus 25 degrees dewpoint when IG density is less than product?	30	Hours
	Time taken to inert from cargo vapour to fully inert at minus 25 degrees dewpoint when IG density is greater than product?	30	Hours

B14 GAS FREEING TO FRESH AIR

14.1	Plant used	PSA	
14.2	Time taken from fully inert condition to fully breathable fresh air?	12,5	Hours

B15 CHANGING CARGO GRADES

Indicate number of hours needed to change grades from the removal of pumpables to tanks fit to load and the estimated quantity of Inert Gas and or Nitrogen consumed during the operation:

	Hours	Air	Nitrogen
From C-Propane to N-Butane	0	0	0
From C-Propane to Butadiene	112	15000m3	20000m3
From C-Propane to Ethylene	NA		
From C-Propane to Ammonia	NA		
From C-Propane to Vinyl Chloride Monomer	112	15000m3	20000m3
From C-Propane to Propylene Oxide	112	15000m3	20000m3
From N-Butane to C-Propane	112	15000m3	20000m3
From N-Butane to Butadiene	112	15000m3	20000m3
From N-Butane to Ethylene	NA		
From N-Butane to Ammonia	NA		
From N-Butane to Vinyl Chloride Monomer	112	15000m3	20000m3
From N-Butane to Propylene Oxide	112	15000m3	20000m3
From Butadiene to C-Propane	112	15000m3	20000m3
From Butadiene to N-Butane	112	15000m3	20000m3
From Butadiene to Ethylene	NA		
From Butadiene to Ammonia	NA		
From Butadiene to Vinyl Chloride Monomer	112	15000m3	20000m3
From Butadiene to Propylene Oxide	112	15000m3	20000m3
From Ethylene to C-Propane	NA		
From Ethylene to N-Butane	NA		
From Ethylene to Butadiene	NA		
From Ethylene to Ammonia	NA		
From Ethylene to Vinyl Chloride Monomer	NA		
From Ethylene to Propylene Oxide	NA		
From Ammonia to C-Propane	NA		
From Ammonia to N-Butane	NA		
From Ammonia to Butadiene	NA		
From Ammonia to Ethylene	NA		
From Ammonia to Vinyl Chloride Monomer	NA		
From Ammonia to Propylene Oxide	NA		

From Vinyl Chloride Monomer to C-Propane
 From Vinyl Chloride Monomer to N-Butane
 From Vinyl Chloride Monomer to Butadiene
 From Vinyl Chloride Monomer to Ammonia
 From Vinyl Chloride Monomer to Ethylene
 From Vinyl Chloride Monomer to Propylene Oxide
 From Propylene Oxide to C-Propane
 From Propylene Oxide to N-Butane
 From Propylene Oxide to Butadiene
 From Propylene Oxide to Ethylene
 From Propylene Oxide to Vinyl Chloride Monomer
 From Propylene Oxide to Ammonia

112	15000m3	20000m3
112	15000m3	20000m3
112	15000m3	20000m3
NA		
NA		
112	15000m3	20000m3
112	15000m3	20000m3
112	15000m3	20000m3
112	15000m3	20000m3
NA		
112	15000m3	20000m3
NA		

Cargo Grade Change Operations that cannot be carried out at sea:

All operation can be carried out at sea but have to load small parcel for gassing up

B17 PRE-LOADING COOLDOWN

The following questions ask the Time and Quantity of coolant required to cooldown cargo tanks from ambient temperature to fully gassed up state sufficient to allow loading to commence.

17.1	Propane - Quantity of Coolant Required	NA	
	Propane - Time required to cooldown cargo tanks from ambient temperature with vapour return line	NA	
	Propane - Time required to cooldown cargo tanks from ambient temperature without vapour return line	NA	
17.2	Butane - Quantity of Coolant Required	NA	
	Butane - Time required to cooldown cargo tanks from ambient temperature with vapour return line	NA	
	Butane - Time required to cooldown cargo tanks from ambient temperature without vapour return line	NA	
17.3	Butadiene - Quantity of Coolant Required	NA	
	Butadiene - Time required to cooldown cargo tanks from ambient temperature with vapour return line	NA	
	Butadiene - Time required to cooldown cargo tanks from ambient temperature without vapour return line	NA	
17.4	Propylene - Quantity of Coolant Required	NA	
	Propylene - Time required to cooldown cargo tanks from ambient temperature without vapour return line	NA	
	Propylene - Time required to cooldown cargo tanks from ambient temperature with vapour return line	NA	
17.5	Ethylene - Quantity of Coolant Required	NA	Tons
	Ethylene - Time required to cooldown cargo tanks from ambient temperature with vapour return line	NA	Hours
	Ethylene - Time required to cooldown cargo tanks from ambient temperature without vapour return line	NA	
17.6	Ammonia - Quantity of Coolant Required	NA	
	Ammonia - Time required to cooldown cargo tanks from ambient temperature with vapour return line	NA	
	Ammonia - Time required to cooldown cargo tanks from ambient temperature without vapour return line	NA	

17.7	VCM - Quantity of Coolant Required	NA
	VCM - Time required to cooldown cargo tanks from ambient temperature without vapour return line	NA
	VCM - Time required to cooldown cargo tanks from ambient temperature with vapour return line	NA

B18 LPG VAPORISER

18.1	Type of Vaporiser		
18.2	Number of Vaporisers fitted		
18.3	Capacity per unit - C-Propane		Nm3/h
18.4	Liquid Supply Rate		m3/h
18.5	Delivery Temperature		degC
18.6	Capacity per unit - Ammonia		Nm3/h
18.7	Liquid Supply Rate		m3/h
18.8	Delivery Temperature		degC
18.9	Capacity per unit - Nitrogen		Nm3/h
18.10	Liquid Supply Rate		m3/h
18.11	Delivery Temperature		degC

B19 BLOWER

19.1	Type of Blower	NA
19.2	Rated Capacity	NA
19.3	Delivery Pressure	NA

B20 CARGO RE-HEATER

20.1	Type of Re-Heater	shell / tube	
20.2	Number Fitted	1	
20.3	Heating Medium	Seawater	
20.4	Discharge rates with seawater at 15 degC to raise product temperature of Propane from -42 degC to 0 degC	200	m3/h
20.5	Discharge rates with seawater at 15 deC to raise product temperature of Ammonia from -33 degC to 0 degC	NA	m3/h

B21 HYDRATE CONTROL

21.1	Type of Depressant?	Ethanol	
21.1.1	Freezing point temperature?	-114	
21.2	Quantity of Depressant Carried?	100	Ltr.
21.3	Means of injection?	hand pump	
	Name any other system used	hot gas	

B22 CARGO MEASUREMENT

Level Gauges

22.1	Are level gauges local or remote?	both
22.2	Name of manufacture	Henry Systems
22.3	Type	FTLG 807
22.4	Rated Accuracy	+/- 3 mm
22.5	Certifying Authority	

Temperature Gauges

22.6	Name of manufacture	WIKA
22.7	Type	Capillar
22.8	Rated Accuracy	0,6
22.9	Certifying Authority	GL

Pressure Gauges

22.10	Name of manufacture	WIKA
22.11	Type	Bourdon tube
22.12	Rated Accuracy	0,25
22.13	Certifying Authority	GL

Oxygen Analyser

22.14	Name of manufacture	Draeger
22.15	Type	O2 LS
22.15.1	What is the lowest level measurable?	0%

Fixed Gas Analyser

22.16	Name of manufacture	Draeger
22.17	Type	Polytron SE Ex

Cargo Tank Calibrations

22.18	Are Cargo tank calibration tables available?	YES
22.19	Name of Measuring Company	ARMINES - Centre de DOUAL
22.20	Name of Certifying Authority	
22.21	Calibration calculated to cm?	YES
22.21.1	Calibration calculated to 1/2 cm?	NO
22.22	Tables established to cm?	YES
22.22.1	Tables established to mm?	NO
22.22.2	Tables established to "other" (state what other)	NA
22.23	Are trim and list corrections available?	YES
22.24	Are temperature corrections available?	YES
22.25	Are float gauge tape corrections available?	YES

B23 CARGO SAMPLING

23.1	May cargo samples be obtained from the levels; top, middle and bottom in all cargo tanks?	NO
------	---	----

If no, - the arrangement for sampling is limited to:

closed loop sampling from bottom via pump

23.2	Can samples be drawn from tank vapour outlet?	NO
	Can samples be drawn from manifold liquid line?	NO
	Can samples be drawn from manifold vapour line?	NO
	Can samples be drawn from pump discharge line?	YES
23.3	State sample connection type	NPT 1/2" FEMALE CONNECTOR
	Size of sample connection	1/2"

Manifold arrangement diagram

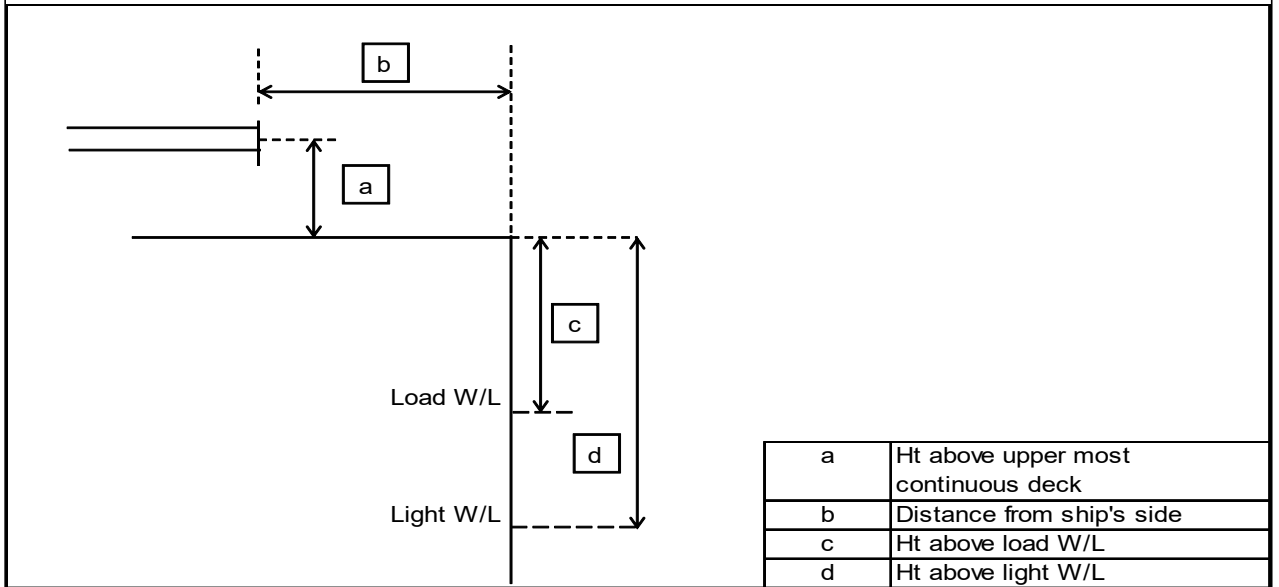
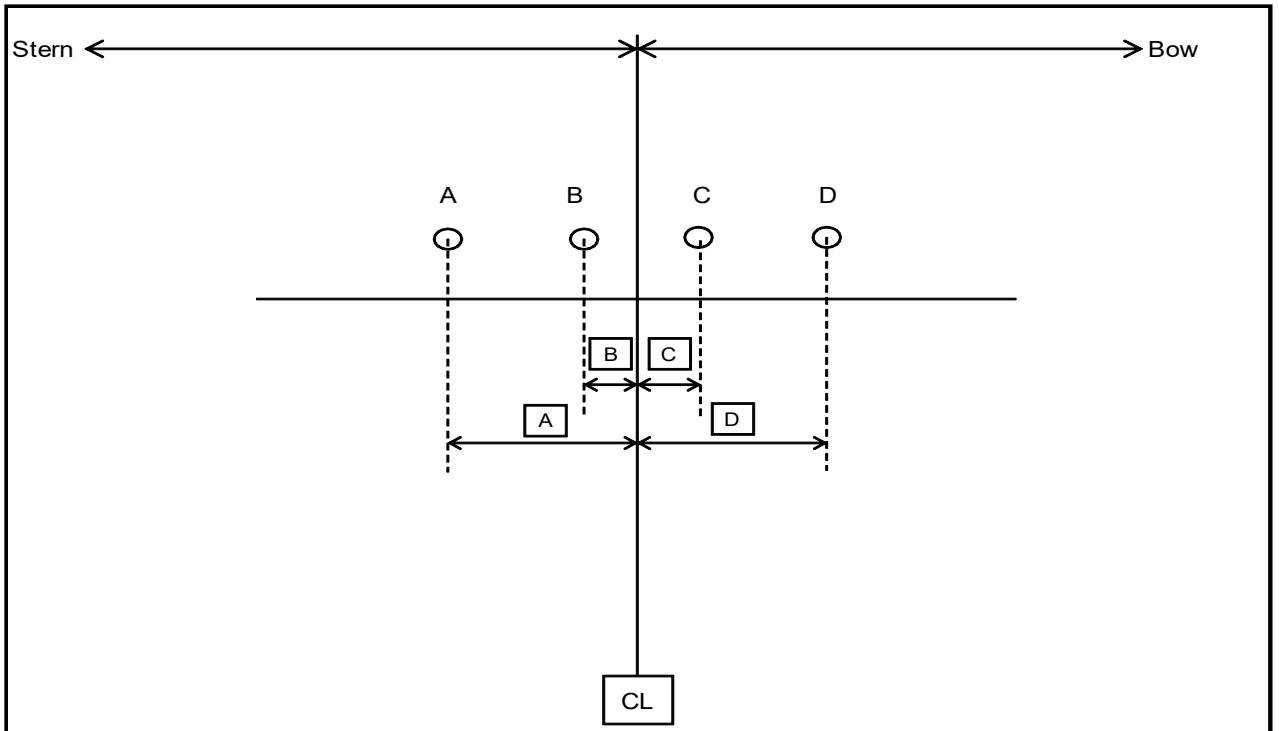

Center of manifold to bow
Center of manifold to stern

49,87	M
50,03	M

Liquid line L1 (D)

Distance from bow
Distance from stern
Distance from manifold centerline (D)

47,62	M
52,28	M
2,25	M

Size and rating
Type

8" ASA	
flat	

Height above uppermost continuous deck
Distance from ship's side

1,70	M
3,10	M

Height above load waterline	6,34	M
Height above light waterline	8,20	M

Vapour line V1 (C)

Distance from bow	49,12	M
Distance from stern	50,78	M
Distance from manifold centerline (C)	0,75	M
Size and rating	4" ASA	
Type	flat	
Height above uppermost continuous deck	1,70	M
Distance from ship's side	3,10	M
Height above load waterline	6,34	M
Height above light waterline	8,20	M

Vapour line V2 (B)

Distance from bow	50,62	M
Distance from stern	49,28	M
Distance from manifold centerline (B)	0,75	M
Size and rating	4" ASA	
Type	flat	
Height above uppermost continuous deck	1,70	M
Distance from ship's side	3,10	M
Height above load waterline	6,34	M
Height above light waterline	8,20	M

Liquid line L2 (A)

Distance from bow	52,12	M
Distance from stern	47,78	M
Distance from manifold centerline (A)	2,25	M
Size and rating	8" ASA	
Type	flat	
Height above uppermost continuous deck	1,70	M
Distance from ship's side	3,10	M
Height above load waterline	6,34	M
Height above light waterline	8,20	M

Liquid line L3

Distance from bow	NA	
Distance from stern		
Distance from manifold centerline		
Size and rating		
Type		
Height above uppermost continuous deck		
Distance from ship's side		
Height above load waterline		
Height above light waterline		

Vapour line V3

Distance from bow	NA	
Distance from stern		
Distance from manifold centerline		
Size and rating		
Type		
Height above uppermost continuous deck		
Distance from ship's side		
Height above load waterline		
Height above light waterline		

Vapour line V4

Distance from bow	NA	
Distance from stern		
Distance from manifold centerline		
Size and rating		
Type		
Height above uppermost continuous deck		
Distance from ship's side		
Height above load waterline		
Height above light waterline		

Liquid line L4

Distance from bow	NA	
Distance from stern		
Distance from manifold centerline		
Size and rating		

Type	
Height above uppermost continuous deck	
Distance from ship's side	
Height above load waterline	
Height above light waterline	
Nitrogen manifold	
Distance from bow	NA
Distance from stern	
Distance from manifold centerline	
Size	
Height above uppermost continuous deck	
Distance from ship's side	

Manifold Arrangement Located on Top of Compressor

Distance from rail of compressor room/platform to presentation flanges	NA
Distance from deck of compressor room/platform/try to centre of manifold	NA

B25 CARGO MANIFOLD REDUCERS

25.1	Number of ANSI Class 300 reducers carried onboard	20	
	Flange rating of ANSI Class 300 reducer	flat	
	Size of ANSI Class 300 reducer	3/4/6/8/10"	
	Length of ANSI Class 300 reducer		MM
25.2	Number of ANSI Class 300 to Class 150 reducers carried onboard	7	
	Flange rating of ANSI Class 300 to Class 150 reducer	flat	
	Size of ANSI Class 300 to Class 150 reducer		
	Length of ANSI Class 300 to Class 150 reducer		MM
25.3	Number of ANSI Class 150 reducers carried onboard	9,00	
	Flange rating of Class 150 reducer	flat	
	Size of ANSI Class 150 reducer	3/4/6/8"	
	Length of ANSI Class 150 reducer		

B26 CONNECTIONS TO SHORE FOR ESD AND COMMUNICATIONS SYSTEMS

26.1	Is ESD connection to shore available?	YES	
	If yes, is the system pneumatic?		
	If yes, is the system electrical?	YES	
	If yes, is the system fiber optic?		
26.2	What is the type of connection used?	MTL SIG04 cable	
26.3	Are ESD hoses or cables available on board?	YES	
	If yes, length of pneumatic		
	If yes, length of electrical	30,00	M
	If yes, length of fiber optic		
26.4	Is there a connection available for a telephone line?	NO	
26.5	Are ESD connections available on both sides of vessel?	YES	
	Are ESD Fusible plugs fitted at tank domes?	YES	
	Are ESD Fusible plugs fitted at manifolds?	YES	
	Is the link compatible with the SIGTTO guidelines?	YES	
	Type of manifold valve	BAC Butterfly valve	
	Closing time in seconds	28,00	
	Is closing time adjustable?	YES	
	Is Independent high level shut down system fitted(overflow control)?	YES	
	If yes, does the independent high level shutdown system also switch off running cargo pumps?	YES	
	Shut down level %	98,00	

B27 MANIFOLD DERRICK/CRANE

27.1	Is manifold derrick provided	NO	
27.2	Is manifold crane provided	YES	
27.3	Is lifting equipment same for port and starboard?	YES	
	If no, then stipulate details		
27.4	State SWL at maximum outreach	4,00	MT
27.4.1	Maximum outreach of lifting equipment	16,50	MT

B28 STORES DERRICK/CRANE

28.1	State location	NA	
	SWL	NA	MT

B29 SISTER VESSEL(S)

29.1	Name of vessel	5	JS Chukar
			JS Alular
			JS Cougar
			JS Jaguar
			JS Lekvar