

Introduction to QuickAI™ EOS-S3-AI Hardware Development Platforms (HDKs)

Board: Merced Rev 1.1

Document Rev 1.2 (January 22, 2019)



HDK PLATFORMS



MERCED 1.1 HDK

- Merced 1.1 HDK: Industrial Applications
 - Time series data collection & model generation
 - Time series Application development
 - Support Arduino form-factor to take advantage of available modules
 - All S3AI pins are available for expansion

HDK PLATFORMS

- Chillkat HDK: Consumer Applications
 - Wearable/Mobile Application demo
 - Small Form-Factor (watch like)
 - Limited available IO for feature expansion



CHILLKAT HDK

HDK PLATFORMS: COMPARE & CONTRAST

- Merced 1.1 HDK
 - What you received today
 - Includes SD Card Feature for AI data Capture
 - Code supports this, but not demonstrated today.
 - BLE Transfer speed is limit to about 100HZ
 - Can stream much more data directly to SD Card
 - This board is in the top of the Fan Demo
- Chillkat HDK
 - Demo & Shown – not handed out
 - Limited supply – if needed, contact QuickLogic Marketing
 - Fits the Wearables-AI market
 - Can do everything Merced 1.1 can do – except NO SD Card
 - Light Sensor and Vibration Motor

MERCED 1.1 HDK: CONTENT

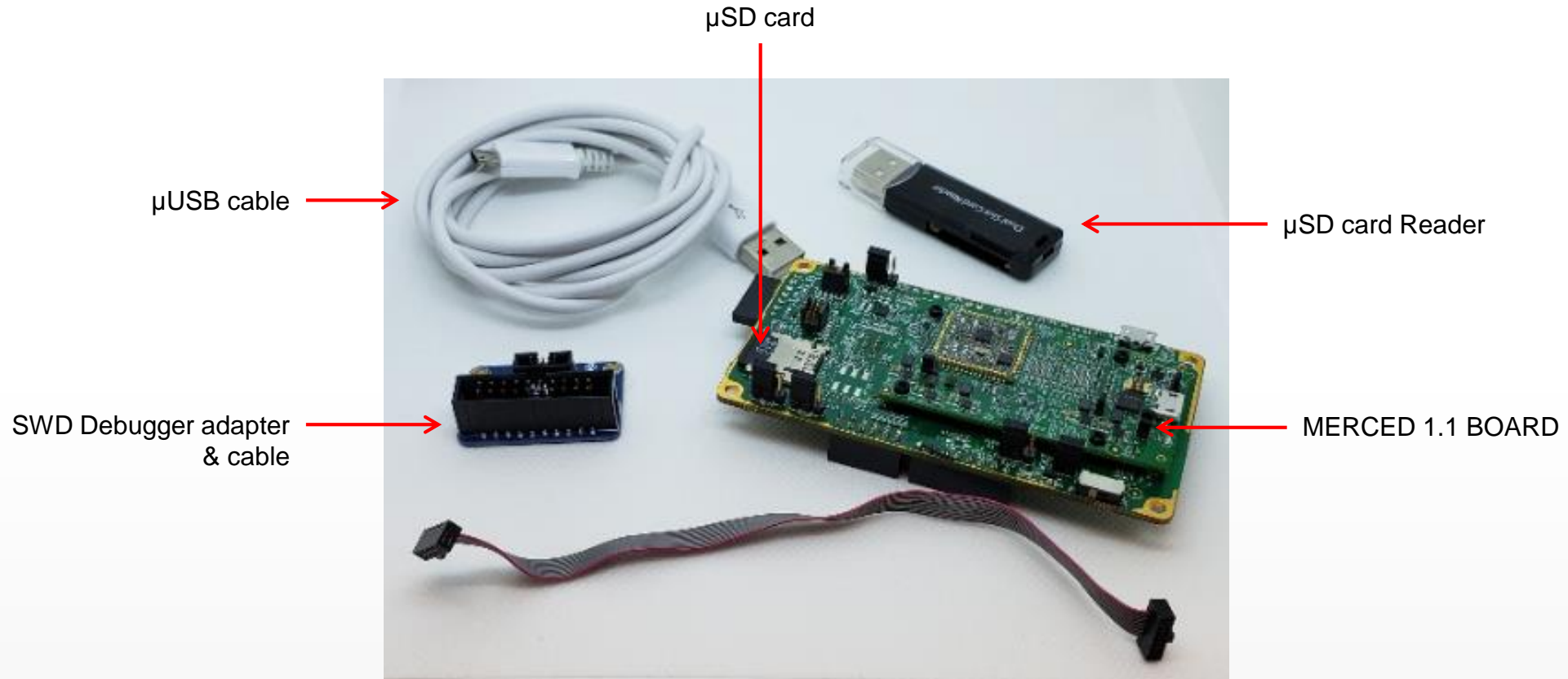

MERCED 1.1 HDK: FEATURES

- QuickAI™ S3AI (BGA package)
- Sensors:
 - 6-axis Accel/Gyro sensor (LSM6DSL)
 - 3-axis Compass (AKM9915)
 - Pulse Density Modulation Microphones (Knowles SPH0641LM4H) – 2x
- 4MB SPI Flash for system information
- USB to UART for system control and debug (FTDI-FT232R)
- Onboard BLE module (BMD200 – nRF51822)
- Arduino connectors
- Boot mode jumpers
- IO Voltage selection jumpers (1.8V and 3.3V)
- Standard ARM SWD Debug connectors
- Li-ion battery and battery charging circuit (see next slide)

MERCED 1.1 HDK: DIMENSION

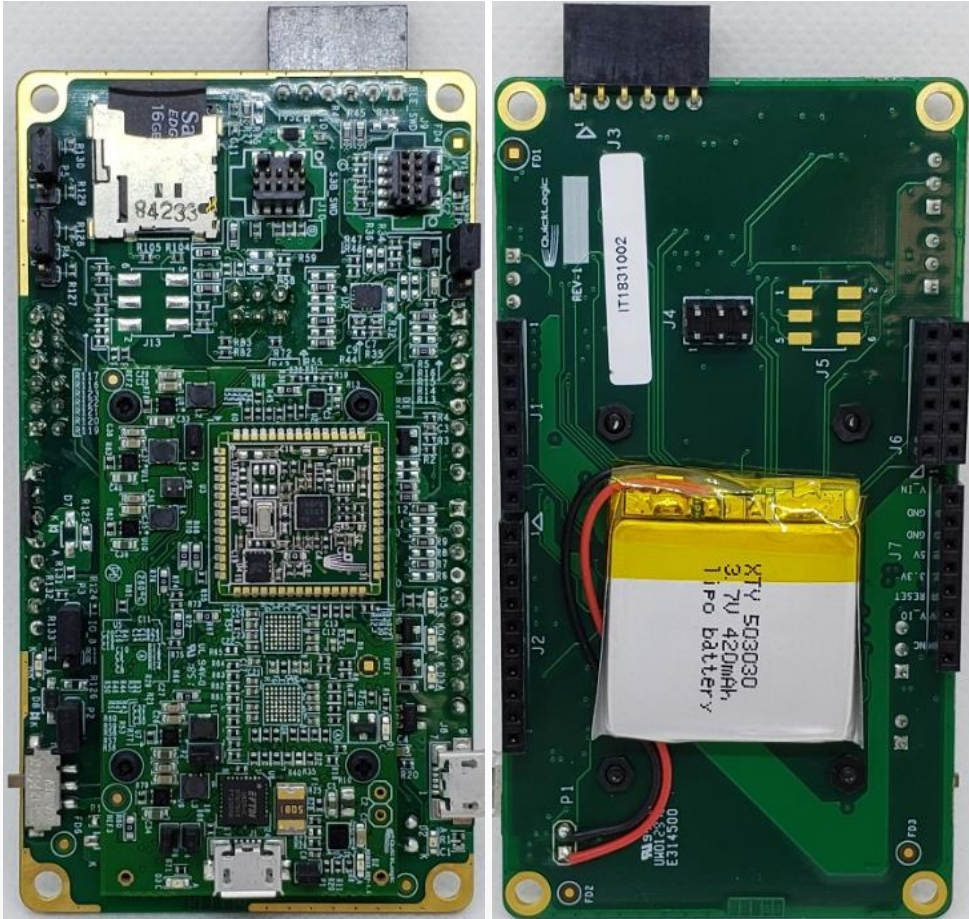

102.9 mm

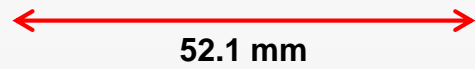

52.1 mm

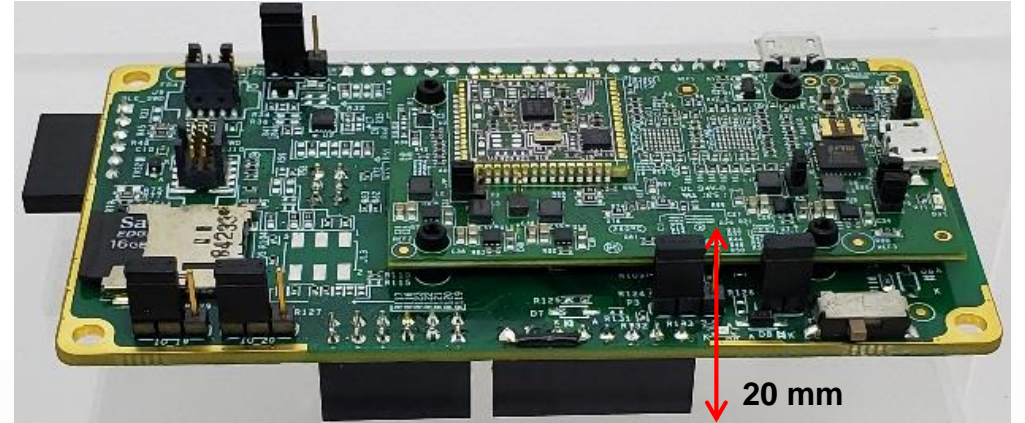

20 mm

MERCED 1.1 HDK: CLOSER LOOK (TOP)

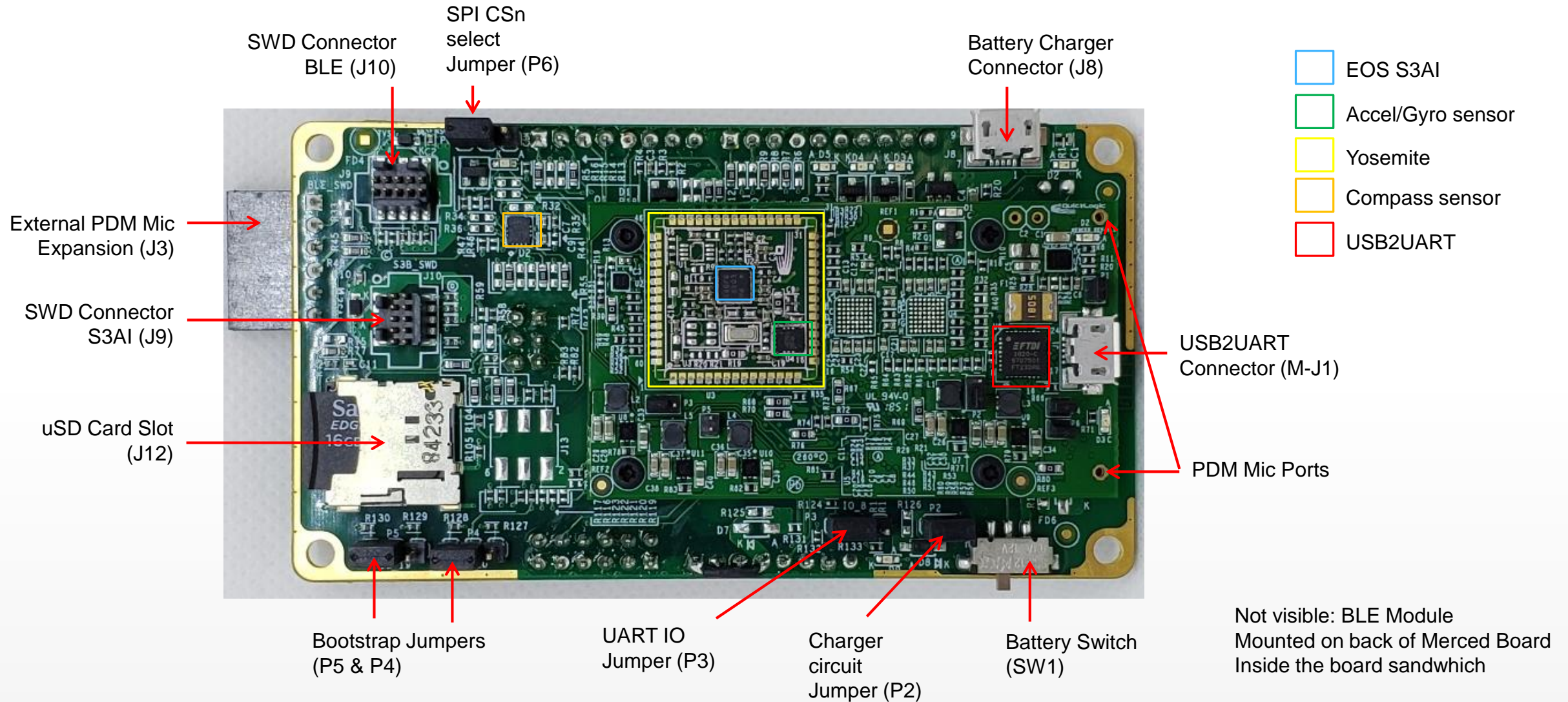

MERCED 1.1 HDK: CLOSER LOOK (BOTTOM)

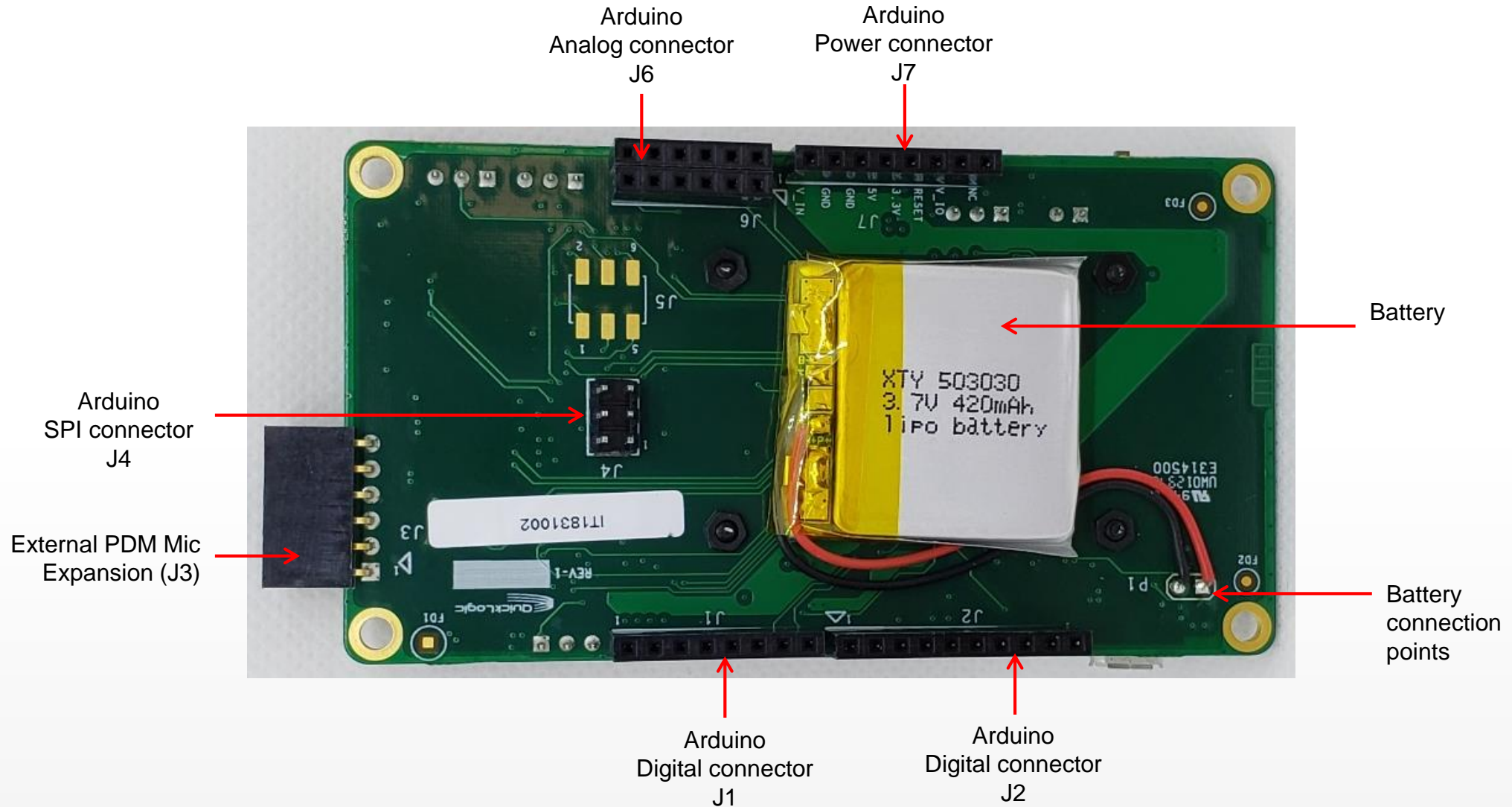

MERCED 1.1 HDK: OPERATIONS - POWER

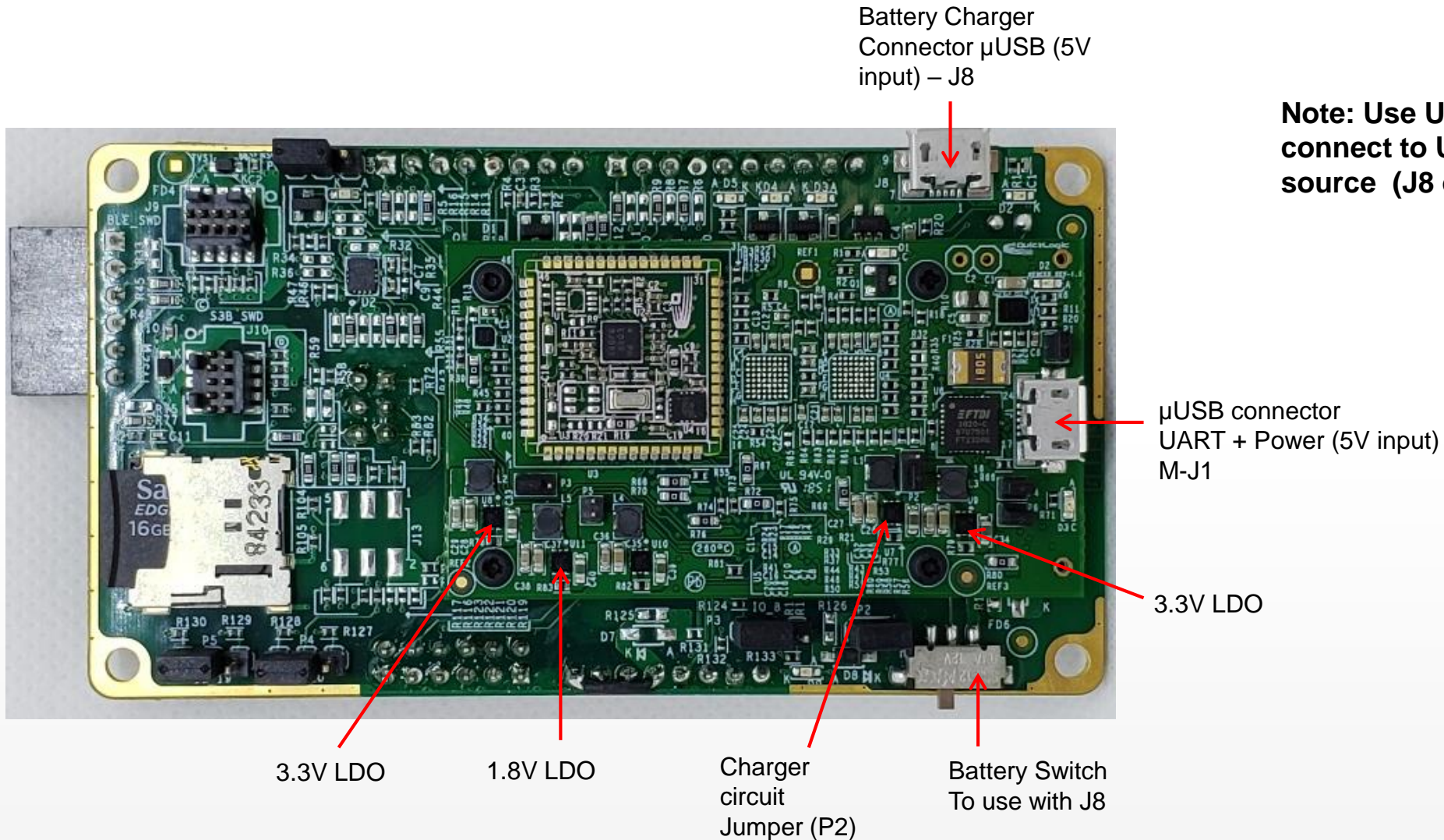

Note: Use USB cable and connect to USB Supply source (J8 or M-J1)

MERCED 1.1 Jumpers

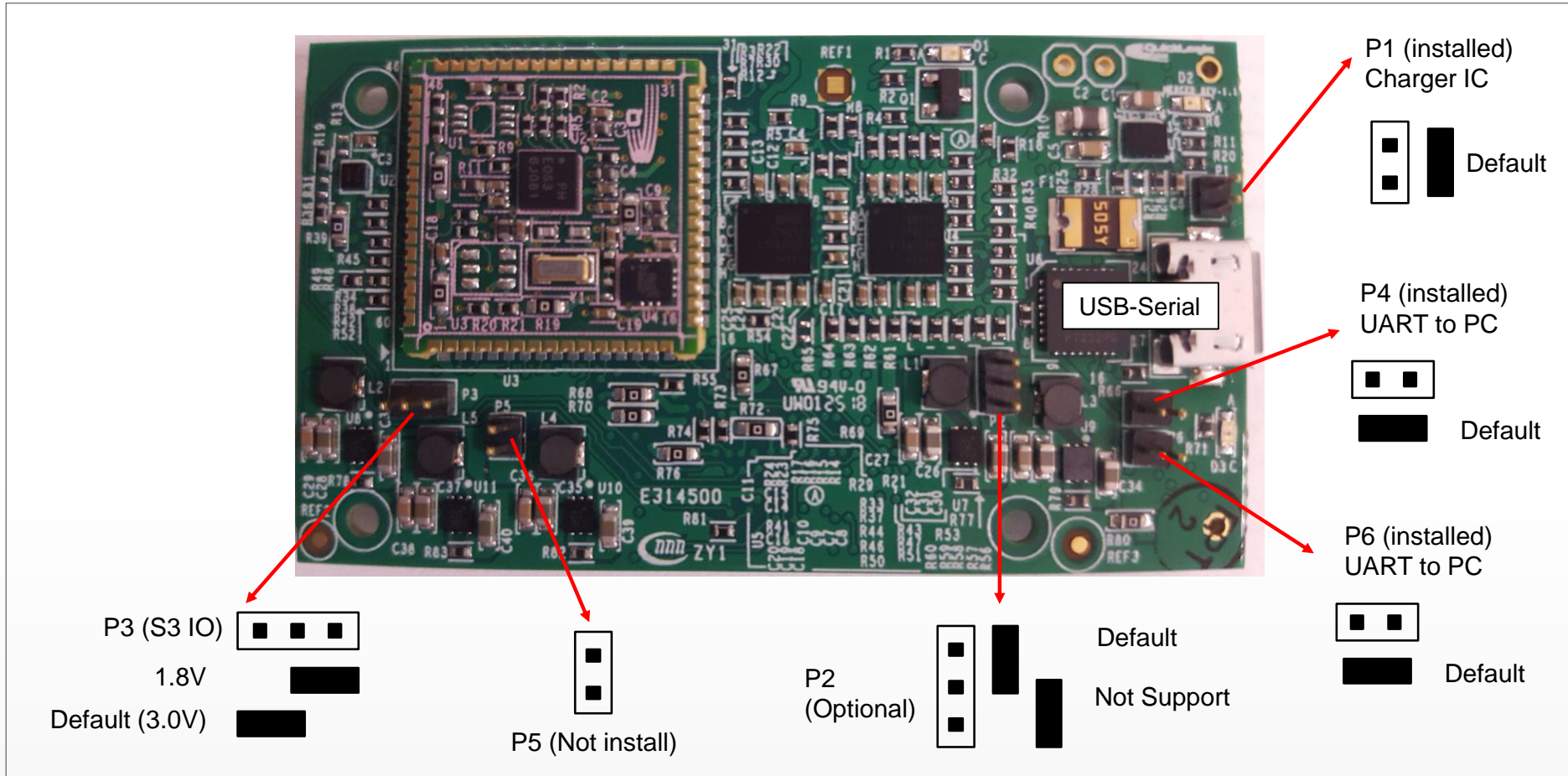

MERCED 1.1 Debug Board Jumpers

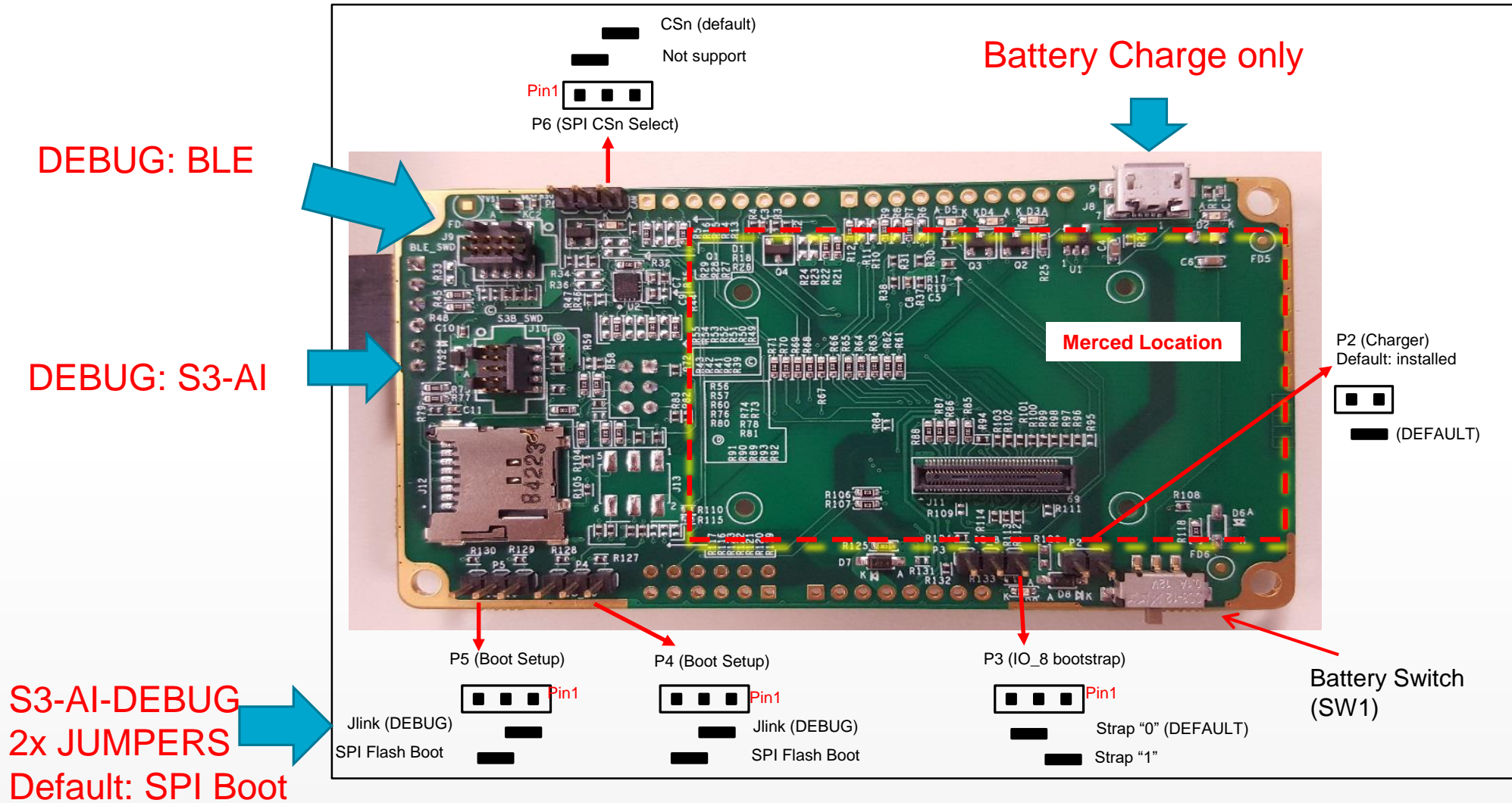

MERCED 1.1 HDK: PreProgramming

- Pre-Programed Software
 - The Merced Board is programmed with a “Fan Demo”
- The AI-model can detect 4 basic states:
 - Off – no vibration
 - On – some vibration
 - Shock – striking or hitting the fan body
 - Imped – On, but something hitting the blades
- See item (4) in the assembly diagram

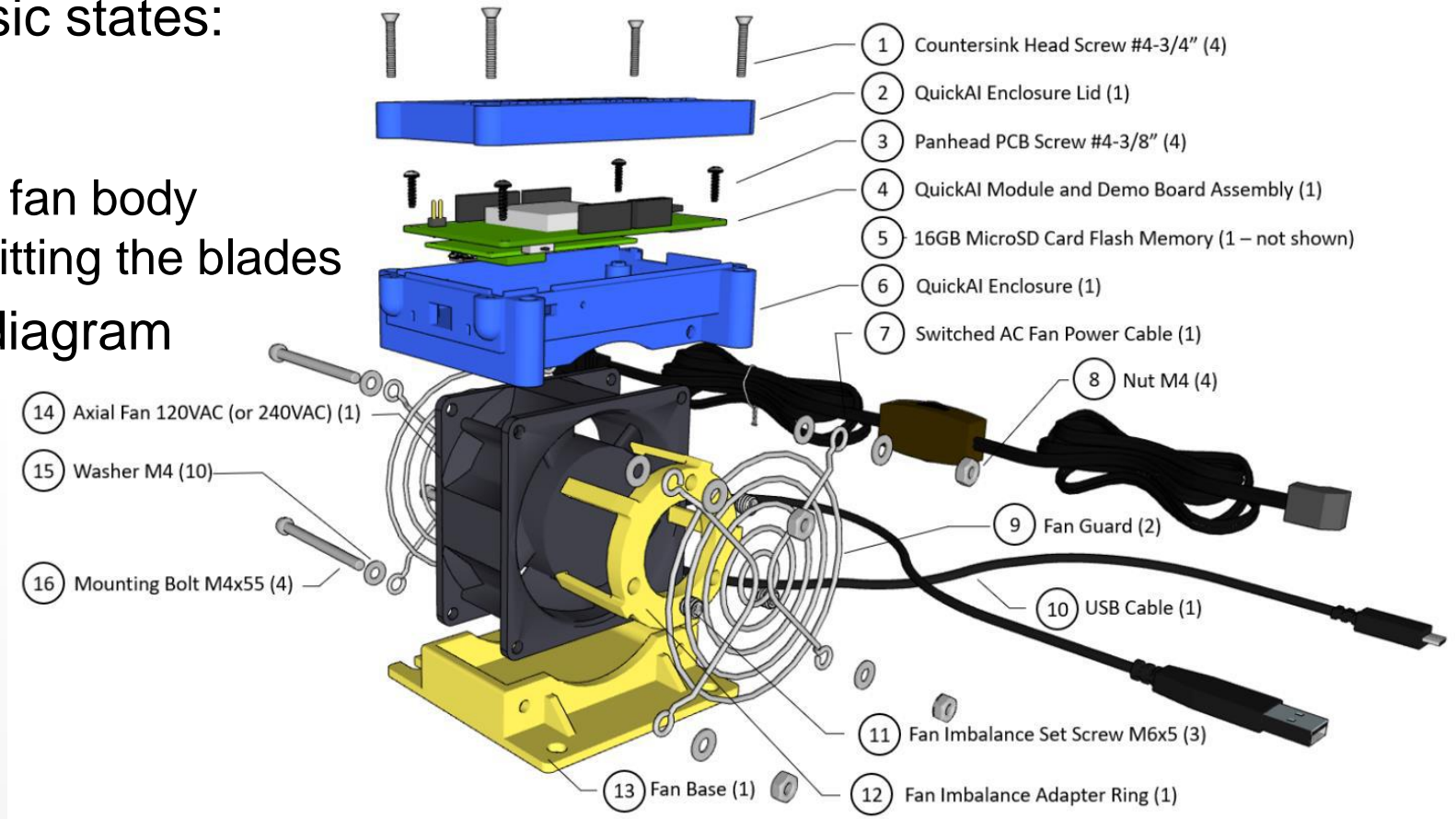

MERCED 1.1 HDK: Connecting to external devices/modules

- Direct connection to available Arduino shields; standard Arduino signals (I2C bus, SPI Master, GPIO, ADC) and DC supplies (1.8V and 3.3V) are available via connector J1, J2, J4, J6, J7.
- External PDM Microphone signals are available via connector J3.
- Blue-wiring is possible for external sensors that support either I2C or SPI bus protocol

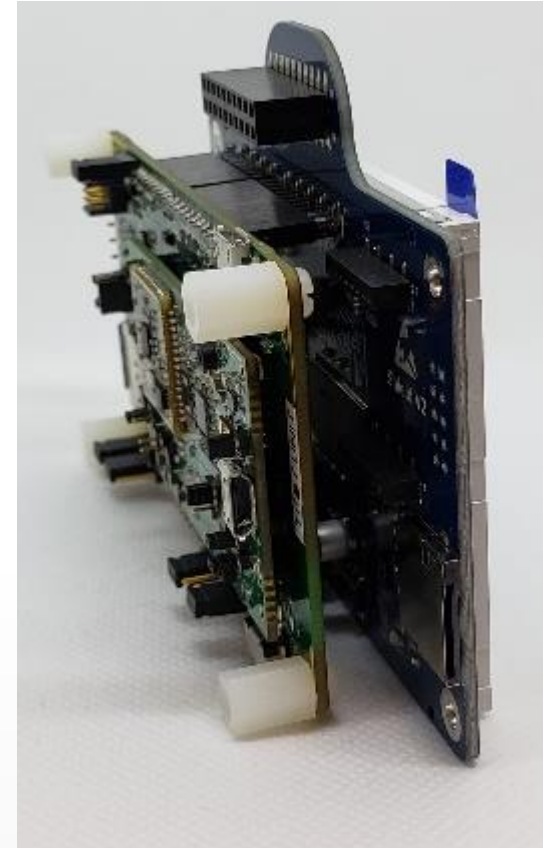

CHILLKAT HDK: CONTENT

Chillkat in Watch Band



CHILLKAT HDK: FEATURES

- QuickAI™ S3AI WLCSP (Wafer Level Chip Scale Package)
- Sensors:
 - 6-axis Accel/Gyro sensor (Bosch BMI160)
 - 3-axis Compass (AKM9915)
 - UV+Ambient Light sensor (Si1132) – not on Merced HDK
 - Pulse Density Modulation Microphones (Knowles SPH0641LM4H)
- 4MB Serial NOR Flash for system information
- Onboard BLE device (nRF51822)
- μ HDMI connector + cable for expansion features
- Standard ARM SWD Debug connectors via Debug Board
- Li-ion battery and battery charging circuit
- Onboard vibrator motor – not on Merced HDK
- Watch band housing to emphasize freedom of movement (Sam?)

CHILLKAT HDK: CHILLKAT BOARD CLOSE LOOK

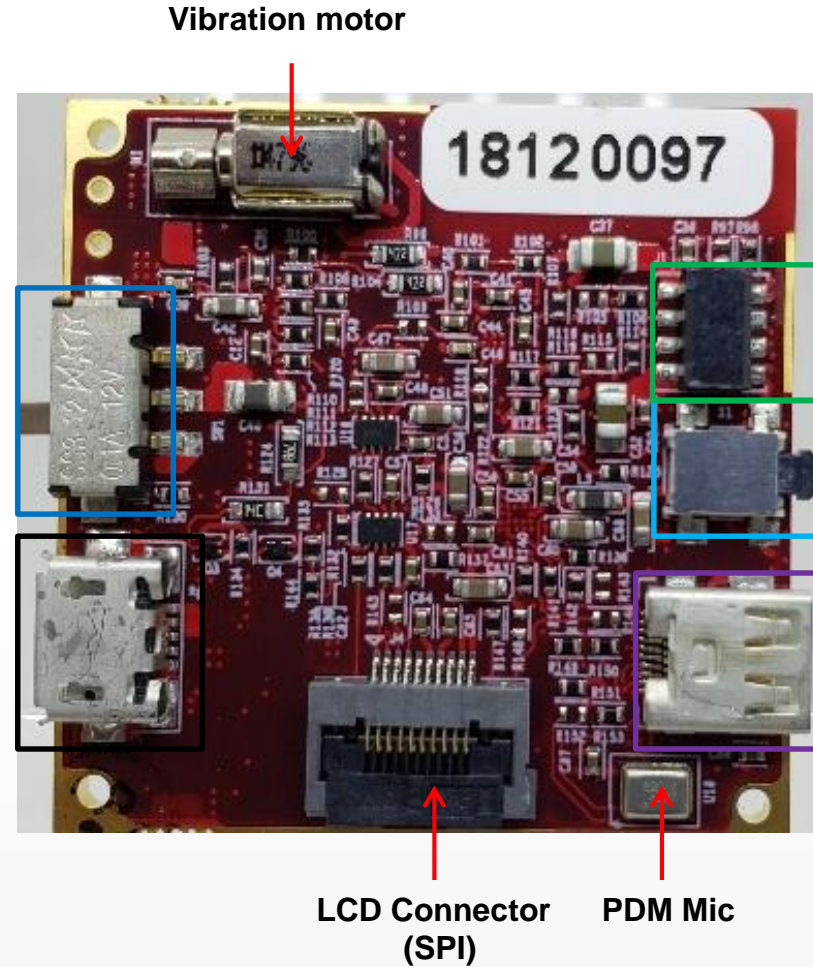
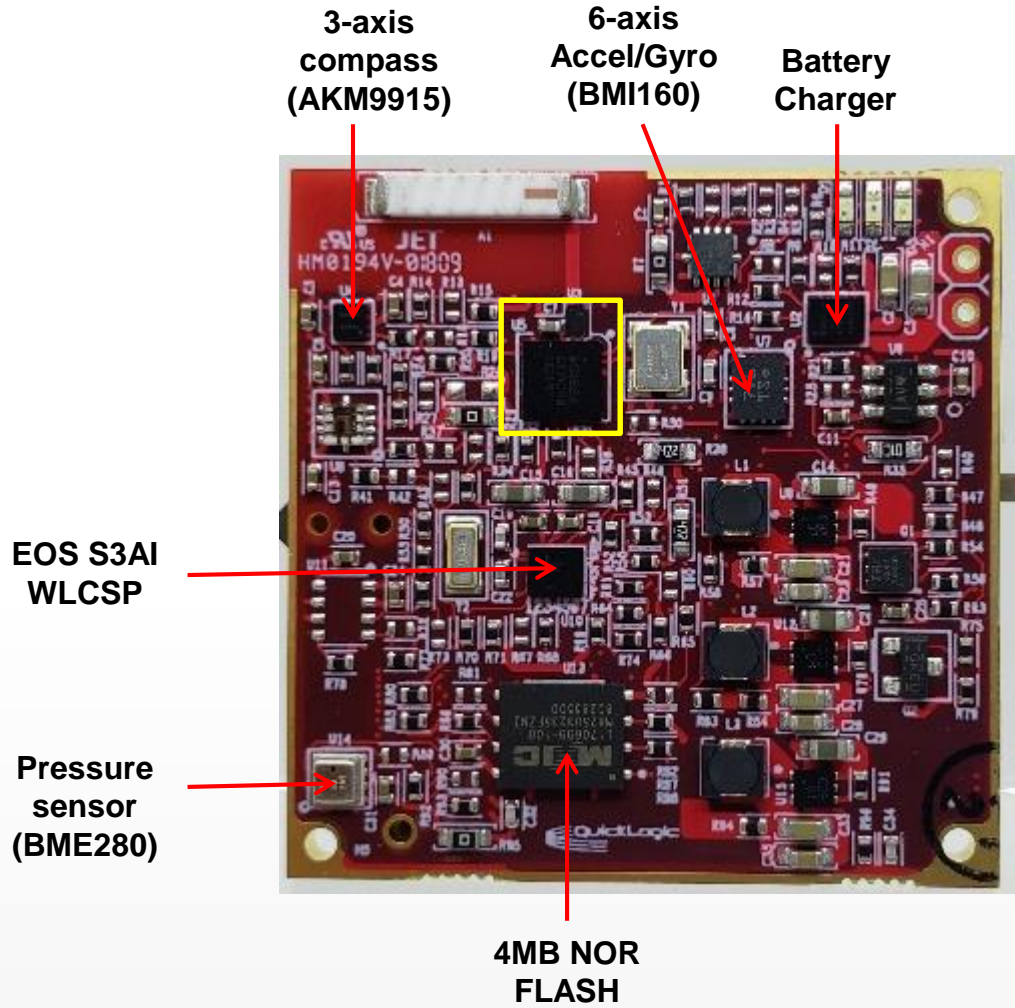

- USB Power
- Power Switch
- BLE (nRF51822)
- Expansion connector
- Reset button
- I2C with Power expansion port

CHILLKAT HDK: DESPLAINES BOARD CLOSE LOOK

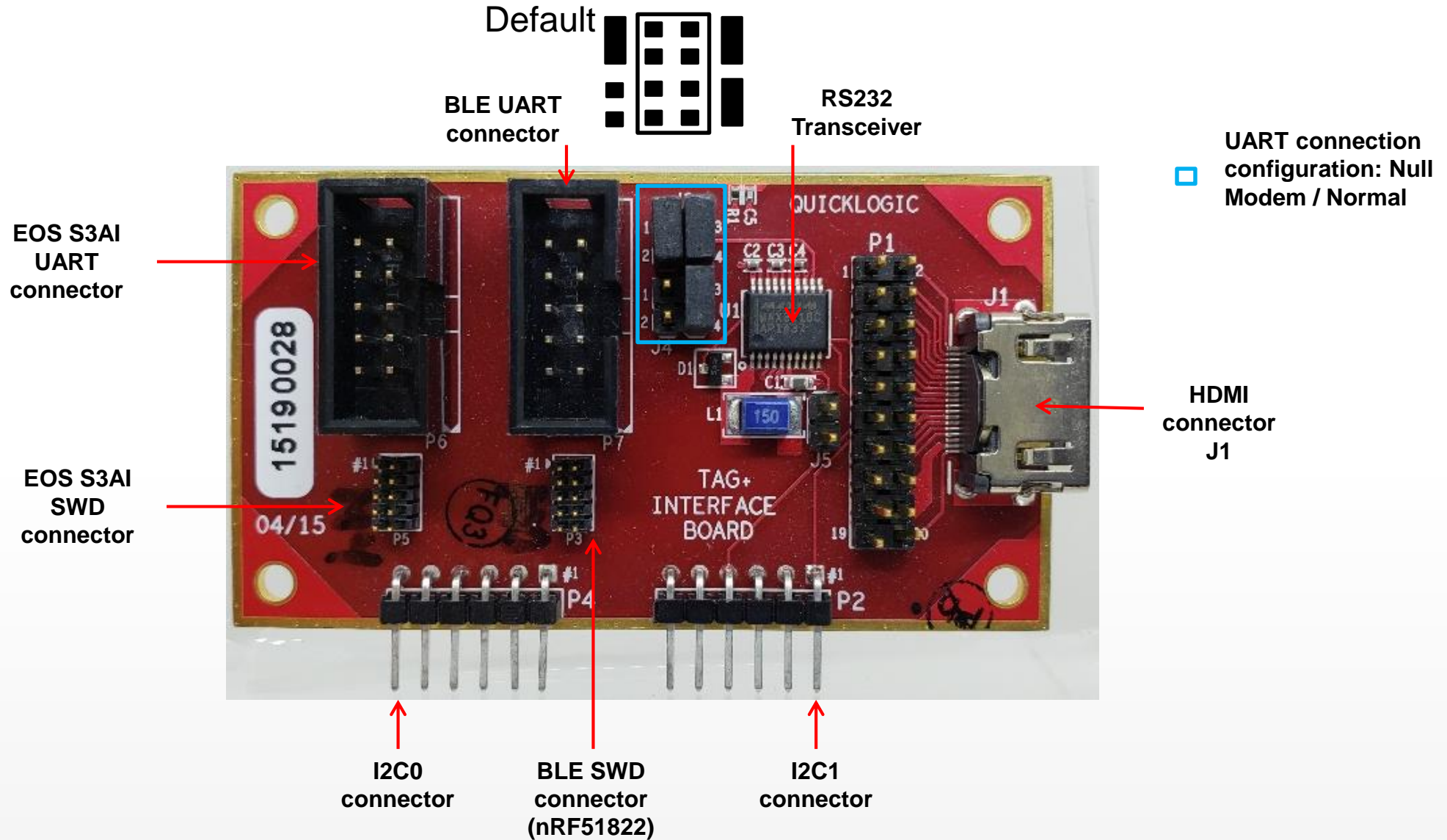

GOOD TO KNOW

- BGA/ WLCSP package available now, QFN available 2019Q2
- SW SDK available now – Supports Eclipse/GCC and IAR
 - On your thumb drive
- S3AI core current measurement via jumper shunt
 - See HDK docs for details
- Merced 1.1 – you have this
 - If Chilkat needed please contact Quicklogic for availability
- Out of box demo:
 - Android App: SensiML – Data Collection Lab (DCL)
 - Android App: SensiML – Test App
 - Merced v1.1 come pre-programed with “SensiML Gesture Demo”