

Oil & Gas Solutions

A UNIQUE APPROACH TO OIL & GAS PROJECTS IN DEVELOPING AREAS



SOLUTIONS PROVIDER

○ KHARTOUM ○ ROME ○ HOUSTON ○ LONDON

Contents

- ❑ About MEFIT
- ❑ Unique Approach
- ❑ Facilities and Services
- ❑ Project Delivery
- ❑ Conclusions



About MEFIT



- ❑ MEFIT is involved in a wide range of activities; from regional and urban planning, and complete design of a commercial or industrial center or a new city to energy projects.
- ❑ MEFIT's experience and expertise in consulting, engineering and project/program management is capable to construct an original overall approach to projects development.
- ❑ MEFIT wide network of Specialists provides to Government agencies or private developers, the expertise required to carry out Analysis, Feasibility Studies, Planning, Budgeting, Engineering and Designing, Tendering and Program/Project management.
- ❑ There is, an outstanding difference between the traditional consultancy approach and the philosophy adopted by MEFIT. The difference is immediately identifiable by the great importance MEFIT attaches to the local cultural aspects of the work at hand.
- ❑ Due to its modern organisation, MEFIT can provide answers to the most complex demands to the satisfaction of clients. The many clients are testimony to the magnitude and quality of MEFIT work.

MEFIT is implementation - from the first idea, possibly a simple line or colour hypothesis, to the completion of the smallest sophisticated detail, fit-for-purpose solutions produce an entire package of comprehensive design and implementation.

MEFIT is dynamic - it aims at the development of the potential creativity, energy and enthusiasm of a youthful staff, supported by experienced and skilful managers who represent the driving force of the company.

MEFIT is agile - know-how and organization bring the most compatible partnerships for any requirement. These qualities insure the commitment and the fulfillment of the project's objective.



Unique Approach

- Shale has changed the industry reduced margins and increased competition among oil and gas producing countries
- New or smaller producers have to look at new ways to participate in the market
- Lower cost of production is key to success



MEFIT Solution

1. Lean organization with just-on-time resources
2. World leading experts
3. Cost effective execution.
4. Standard design fit for purpose
5. Supply chain and construction input part of the design
6. Client centric



MEFIT Solution

MEFIT services range from the initial development to the full implementation covering all aspects:



MEFIT is the ideal partner for an owner to ensure the right resources, tools and processes are in place to ensure successful execution of their hydrocarbon project.



Facilities & Services

- MEFIT comprehensive services range the full suite of oil and gas facilities from the well head to the doors of the refinery or chemical plant.
- MEFIT provides global technical expertise and flexible execution from the conceptual stage to the full stage for new facilities and existing ones.



Oil & Gas Facilities

- ✓ Well site facilities & gathering systems
- ✓ Separation (oil, gas, water)
- ✓ Gas processing & liquids
- ✓ Flare and emergency systems
- ✓ Enhanced oil recovery (EOR)
- ✓ Pipelines, terminal facilities, gathering systems
- ✓ Water & water management
- ✓ Infrastructure, power, and utilities

Oil Separation Plant Schematic

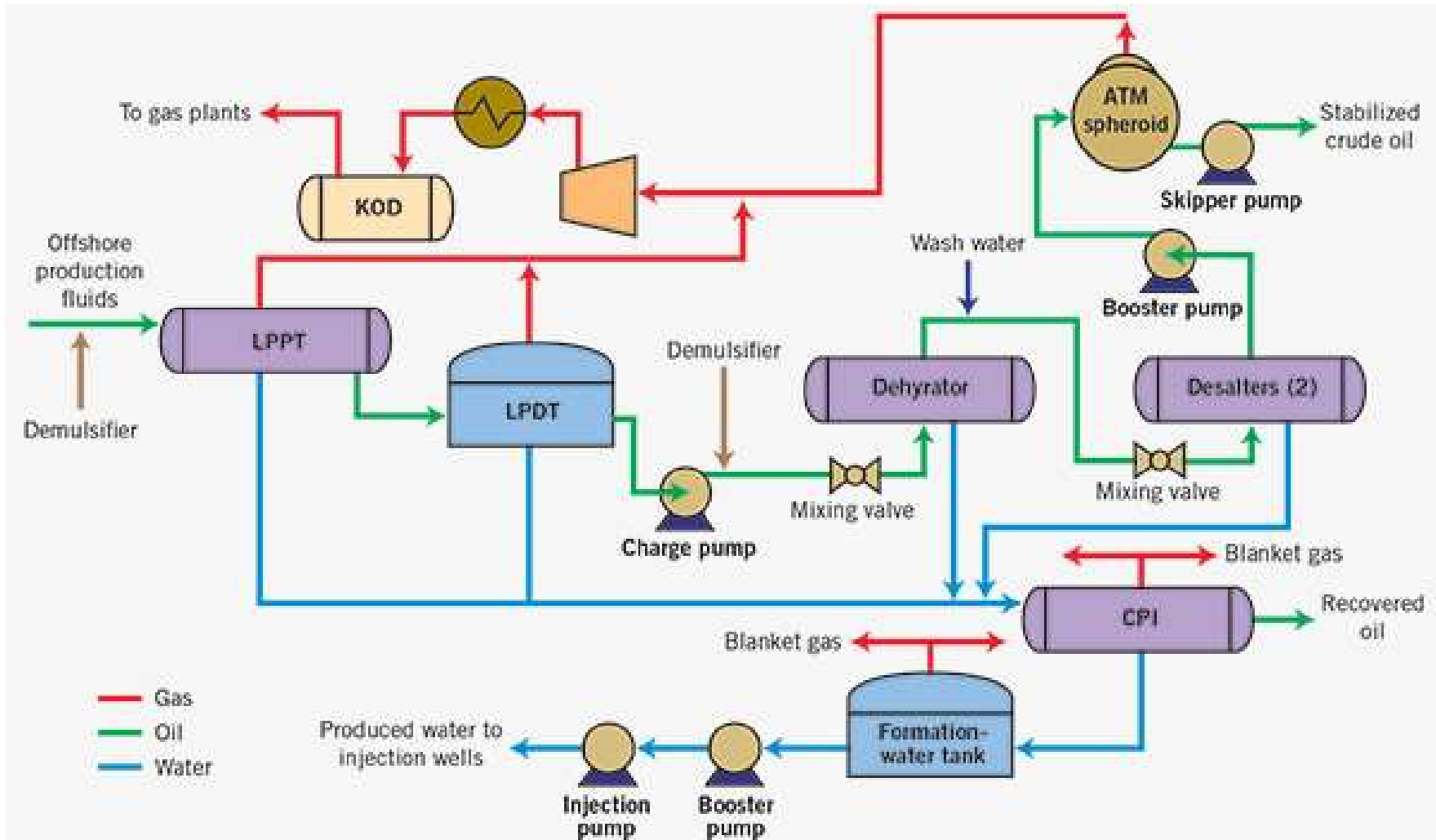

Gas Treatment Plant Schematic

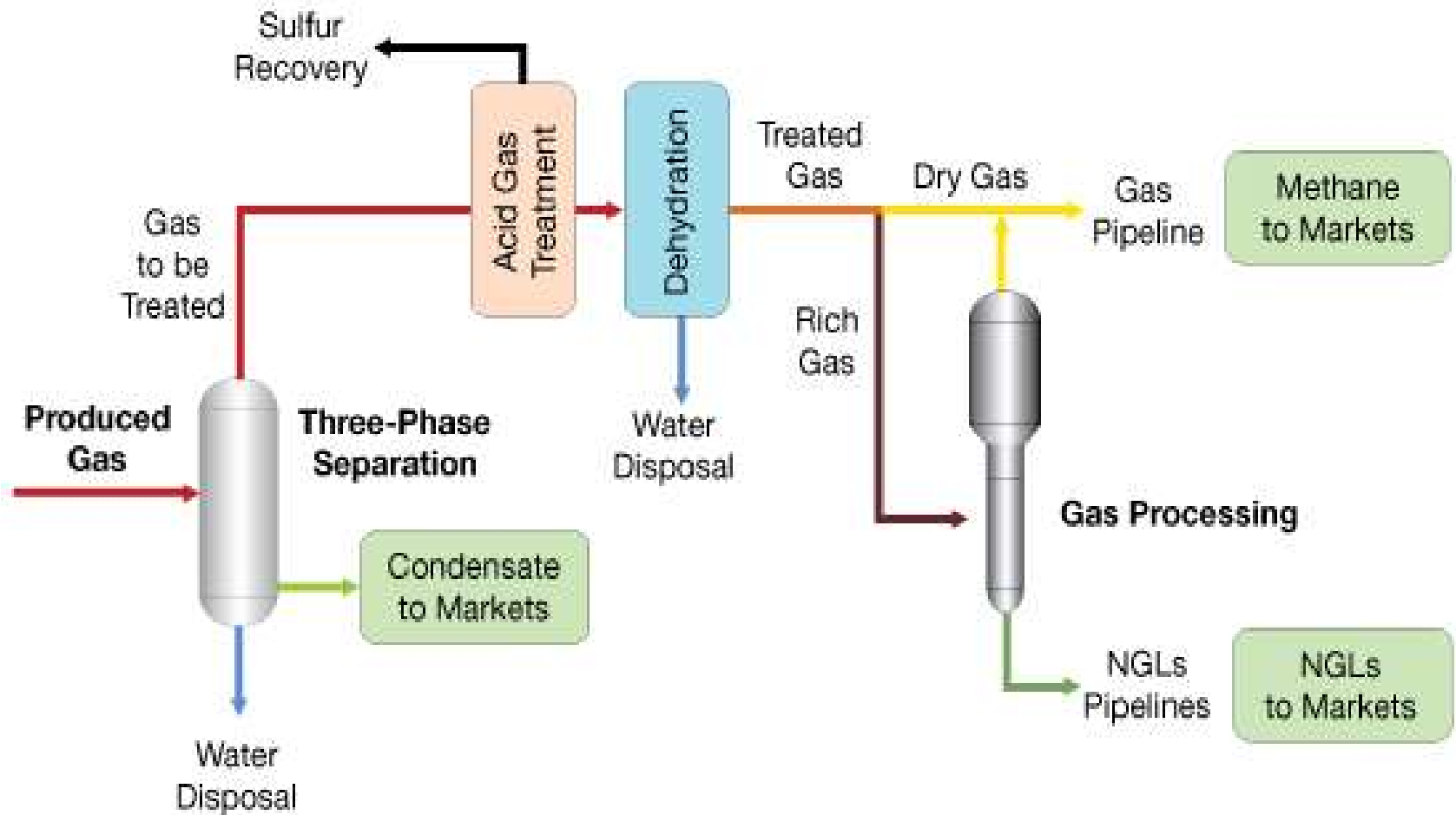

Services



Conceptual
Studies

FEED

Detailed
Design

Construction
Commissioning

Operation
Support

- ✓ Conceptual/Feasibility studies
- ✓ Technology evaluation and Selection
- ✓ FEED
- ✓ Basic Engineering
- ✓ Detailed Engineering
- ✓ Construction Management
- ✓ Modularization

- ✓ Fabrication
- ✓ Erection and Construction
- ✓ Pre-commissioning and Commissioning
- ✓ Operation Support
- ✓ Operators training (Field, Class Room and DCS)
- ✓ Operation and Maintenance Manual

- ✓ Process Optimization/Design Review
- ✓ Trouble Shooting /De Bottlenecking Solutions
- ✓ Reliability & Availability Study
- ✓ Corrosion Study/Evaluation
- ✓ Plant Performance Review
- ✓ HAZOP/HAZID/SIL

SOLUTIONS PROVIDER





Project Delivery

- Projects fail to succeed due to project management issues during execution, not technical capabilities.
- MEFIT processes and procedures provide consistent performance regardless of team members.
- MEFIT has the ability to monitor projects and to accurately forecast project performance: no surprises.
- MEFIT brings execution efficiency through Benchmark Data, library database, knowledge base, workflows, IT support.



Delivery Excellence

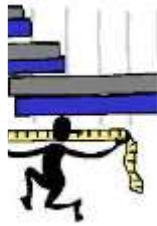

PROJECT BASELINE

- Consistent baseline method
- Facilitate project startup
- Objective change management
- Consistent project monitoring

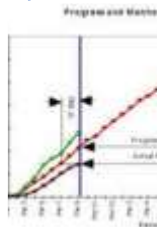

PROGRESS MEASUREMENT

- Auditable and independent
- Standard Rules of Credit and Workflow



RISK MANAGEMENT

- Look-ahead
- Database
- Lessons learned and integrated in the value chain



PROCESS WORKFLOWS

- Consistent Work Quality
- Worksharing



LOCATION

- Experts in Houston and Rome
- Cost effective delivery
- High availability production



CONTINUAL IMPROVEMENT

- Plan Do Check Act Process
- Standards and benchmarks
- Continuous feedback

Conclusions

1. MEFIT has the expertise and know how to understand not only the technical aspects but also the socioeconomic and cultural requirements of an oil and gas project in a developing environment.
2. MEFIT is the ideal partner because of its unique organization to provide the highest quality services and products at the most cost competitive value.

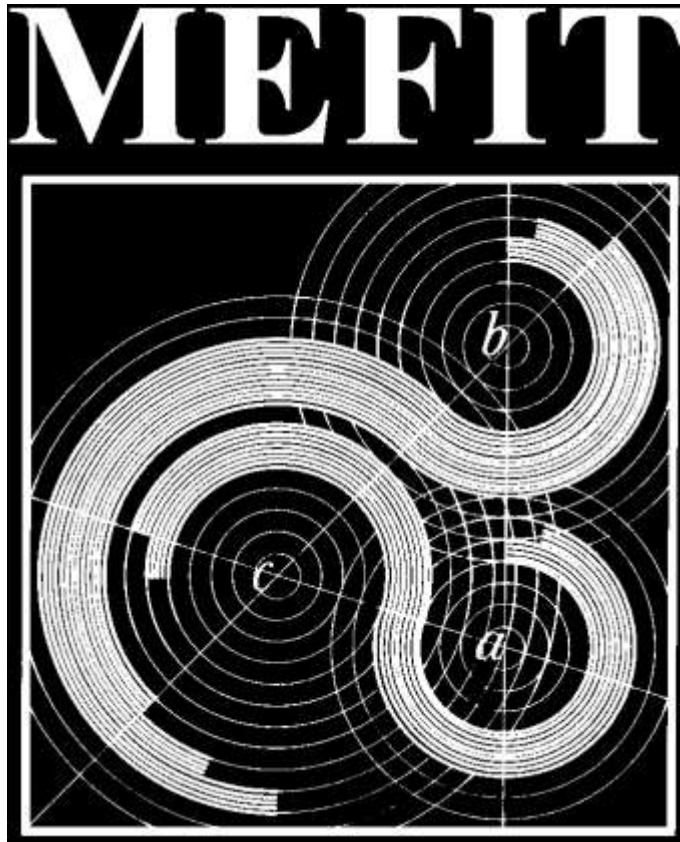

All Rights Reserved Mefit Ltd. 2017



Thank You!