

SO-
UND
SY-
STE-
MS

NORTHGATE

002

THE INTRODUCTION

010

MORNING

020

DAY

030

A BREAK

040

AFTERNOON

050

EVENING

060

NIGHT

070

HOUR AFTER HOUR

092

THE FINISHES



PARTITIONS THAT GENERATE NEW IDEAS

Citterio Sound System is a complete system of cubicles, finishing screens and panels that improve sound absorption making the work environment more comfortable and performing. C-SS is a family of cubicles made of aluminium, glass and wood fibre panels that ranges from phone-booths to medium-sized meeting rooms. Each cubicle is finished with highly-soundproofing patented finishings, flat or pyramid-shaped.

W-SS is a series of cubicles entirely made of solid wood and acoustic panels. This is Citterio's technical and design-oriented solution to meet the market's increasing attention towards natural and recyclable materials. Sound-absorbing panels, flat or pyramid-shaped, can be installed also in large installations, on ceilings or walls, and can be used to correct the acoustics in offices, meeting rooms and auditoriums.

Island is a system of self-supporting screens of various height, used to separate workstations and to correct their acoustics. Sound System matches and integrates with architectural elements, aiming at obtaining the best acoustics and environmental quality.





Aluminium, wood and glass parts that shape up small working areas inspired to the principles of functional minimum design. Different types of patented acoustic panels, pyramid-shaped or flat, designed to capture sound and create a more comfortable environment.

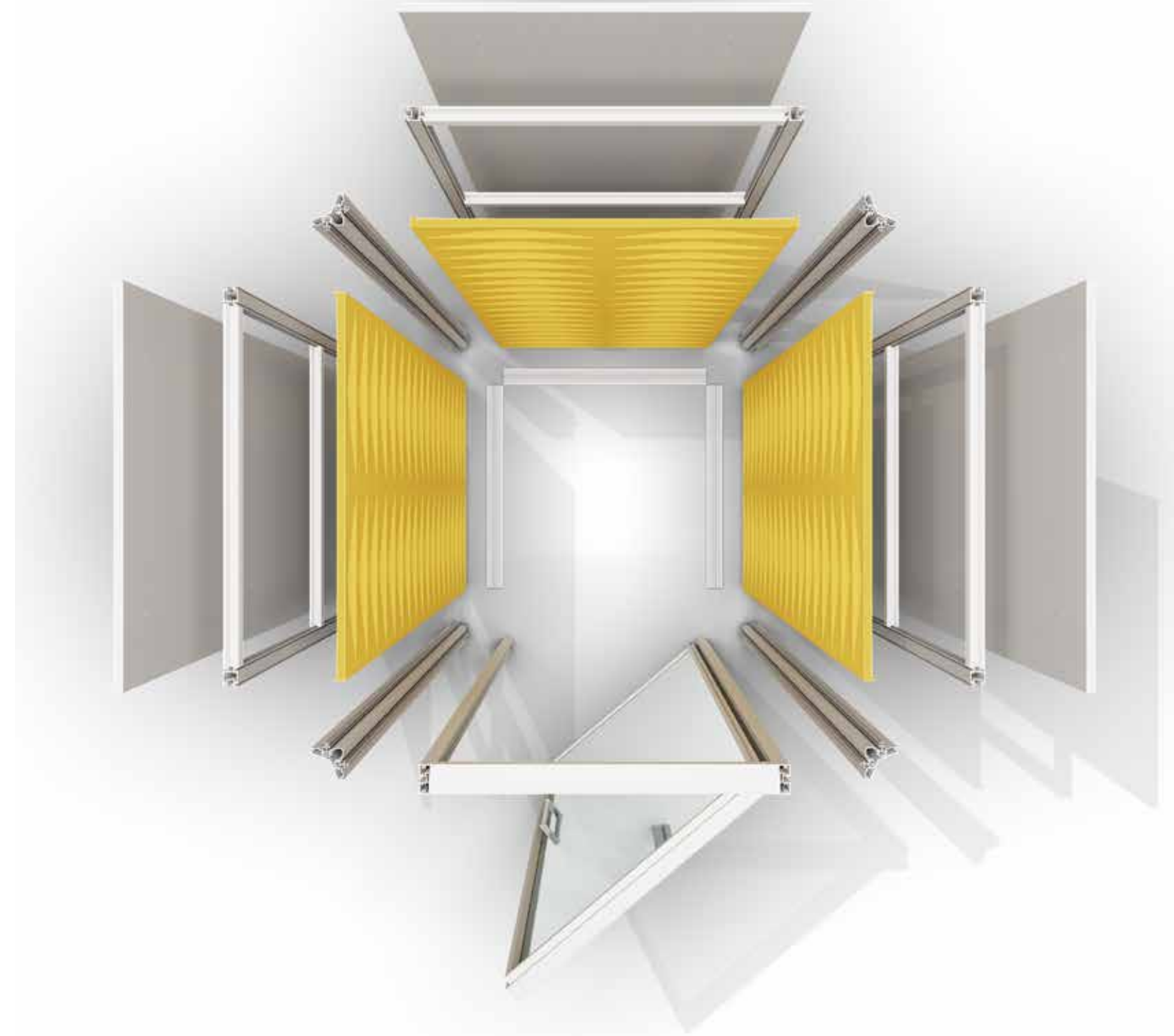

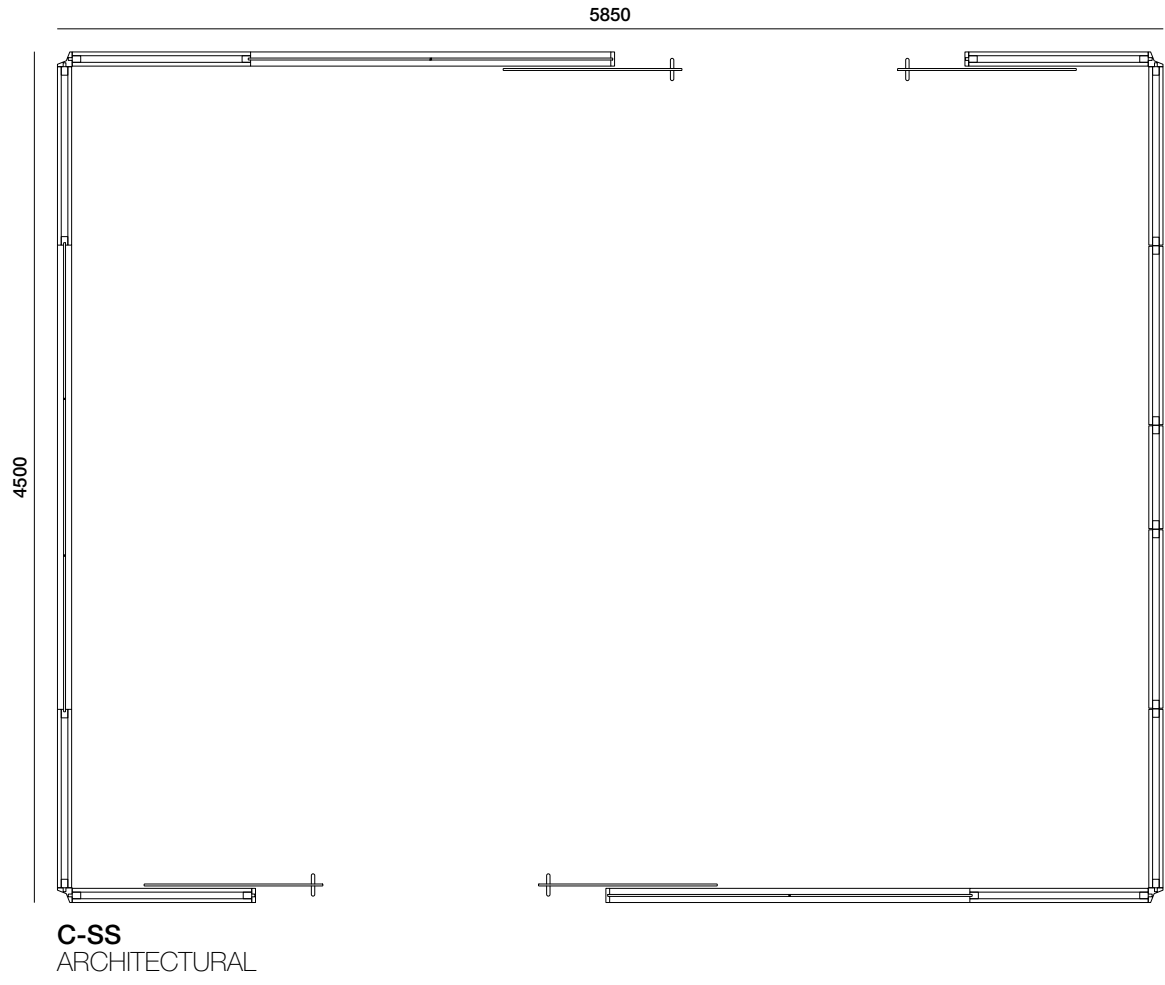
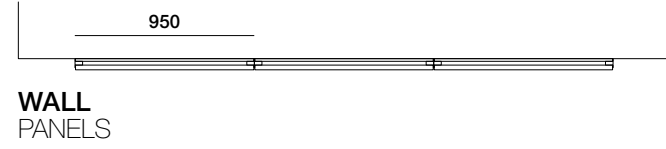
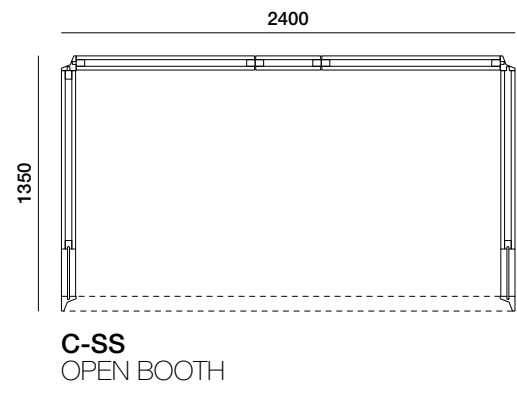
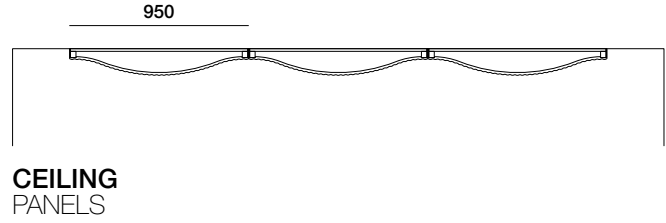
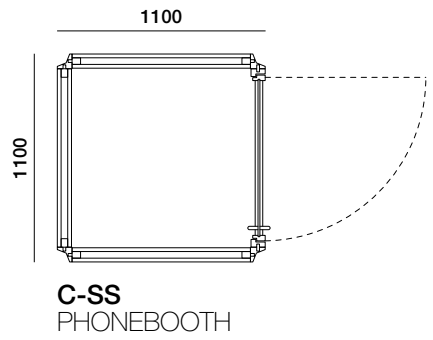

Sound system is architecture within architecture. Four ranges of products to be used in work environments, with different performance and shapes, free-standing or integrated. A group of soundproof islands, closed or open, designed to host meetings, work or private conversations.

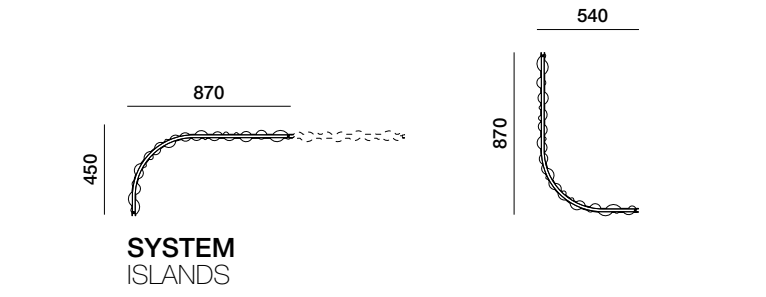
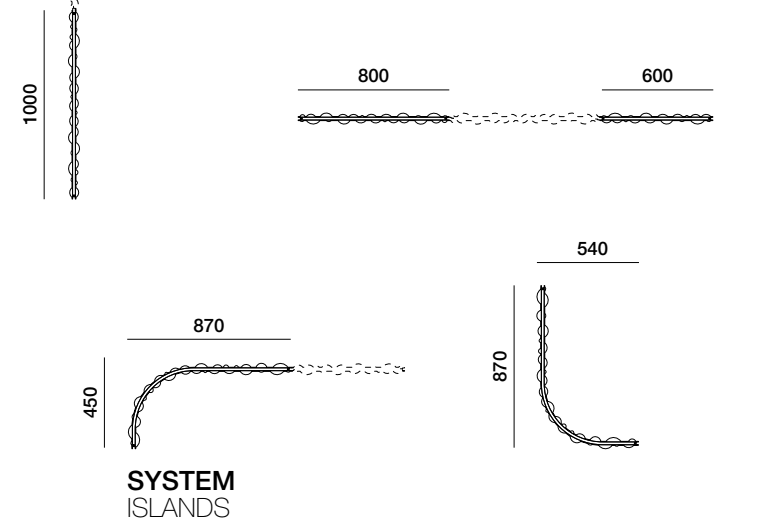
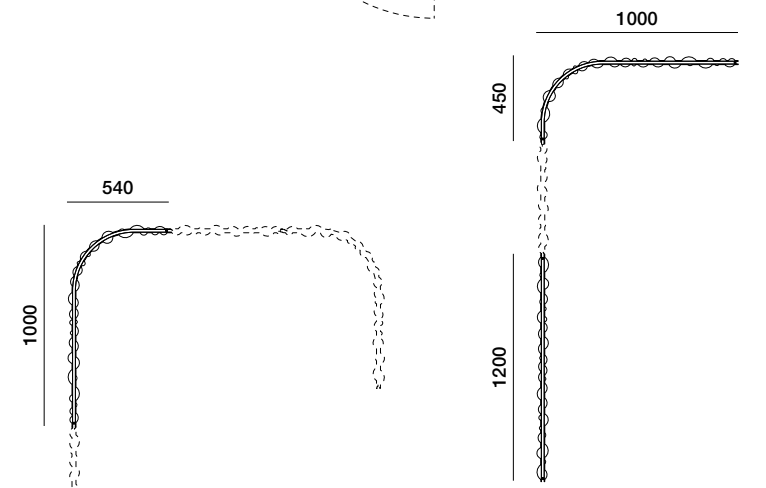
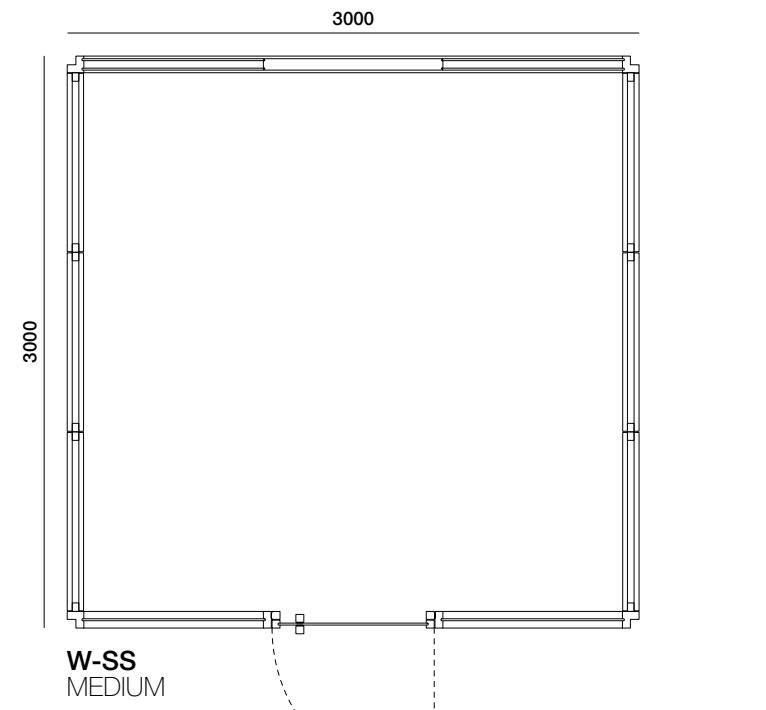
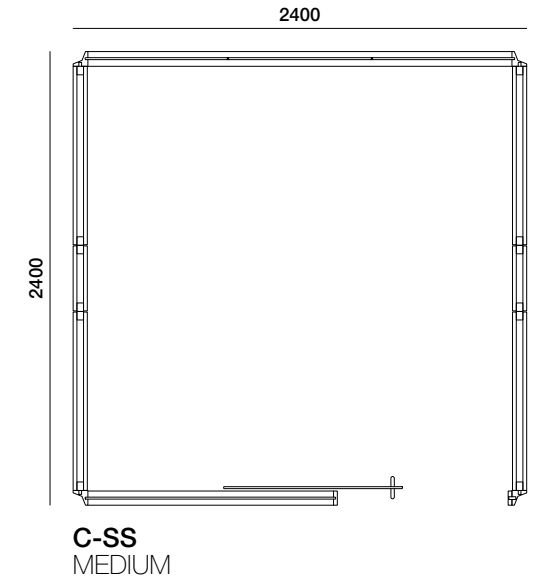
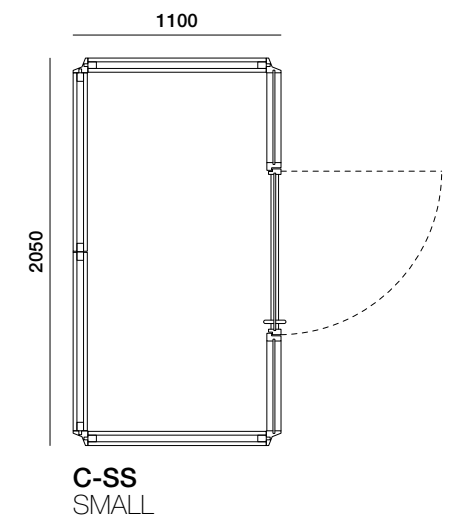

9.00 am

When the day gets busy and everybody is running to start something, to reach places or meet people. Voices, sounds, hectic lives crossing, paths that are shared yet different. When silence becomes a shelter, it is welcomed as an unexpected surprise that helps concentration and focus.

C-SS

MORNING



9.00 am



Oak wood side element with natural oxidized aluminium profiles



90° corner



Square-section handle





Shaped wooden shelf

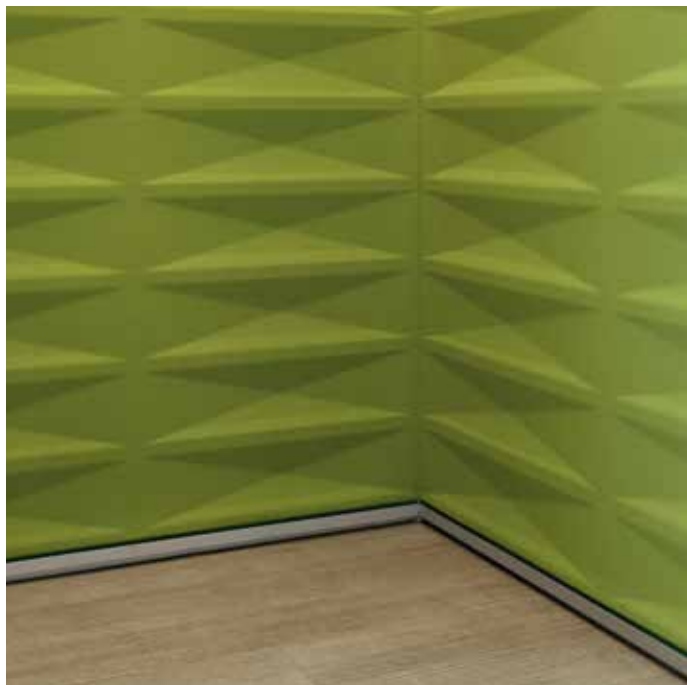

Internal corner

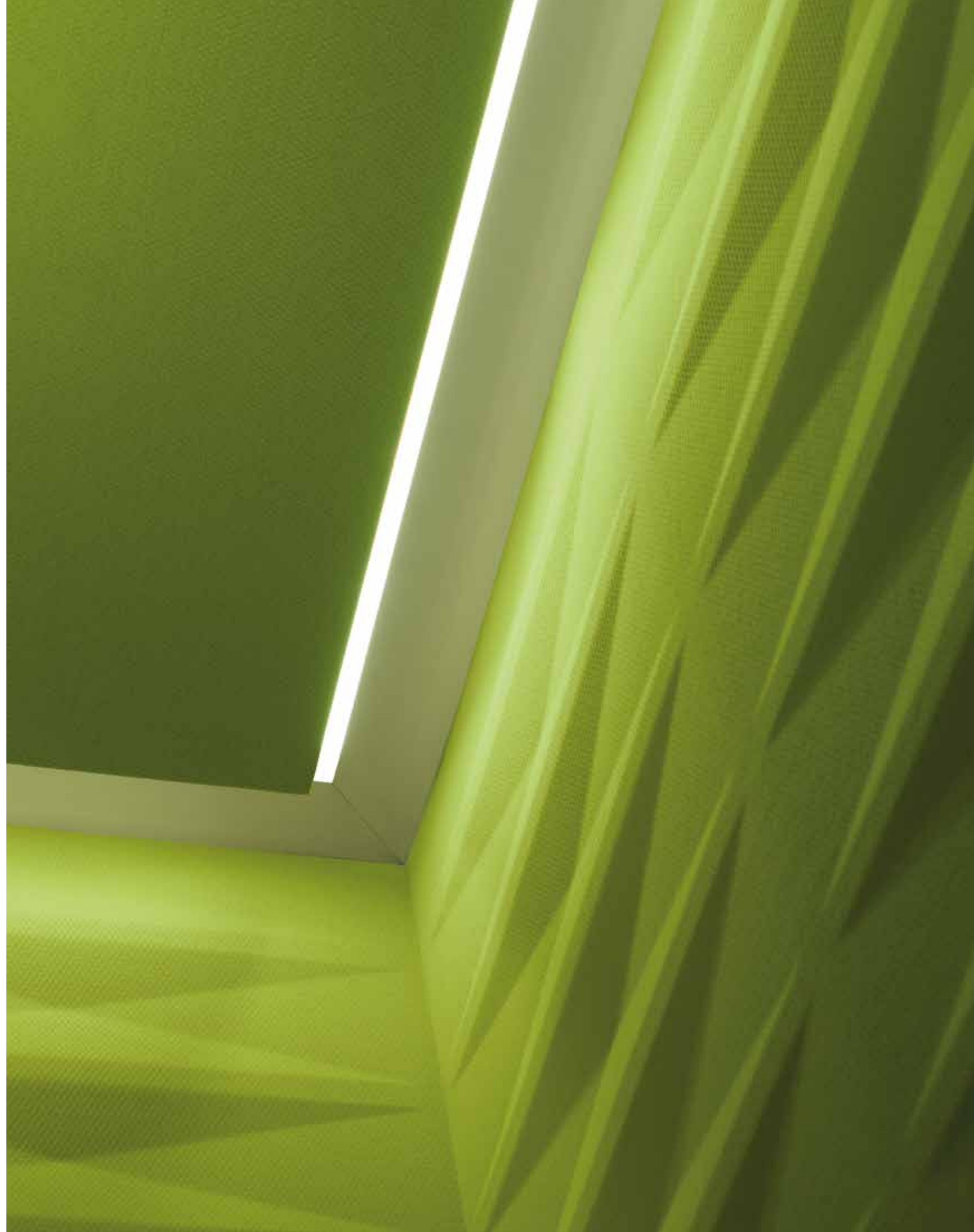

11.00 am

When work becomes intense, crowded with thoughts and words. Countless rings, repeated movements, breaks and new starts. Non-stop interactions between different stories, private dimensions that become public. When you want to talk and understand and you need a place away from everything and everybody.

C-SS

DAY



11.00 am

Solid dark oak wood side element with glass corner



Glass-wood junction





Painted aluminium corner



Wood internal service element



1.00 μm

When everything stops and everybody feels it's time for a break from all those ordinary actions and pressing thoughts. Detachment, seclusion, a break, or just relaxed contacts, exchange, quiet interactions. And maybe the pause can be found in a book, a touching music, good food, on in an extremely cosy corner.

C-SS

A BREAK





Front profiles in painted extruded aluminium

Integrated switches





Larix titanium panels





4.00 μm

When we all struggle to find our place and show our value. Every sound or creative action suddenly becomes unanimous, the pace gets faster and the melody starts flowing. When the music changes and detachment becomes vital, attention becomes essential to help us find the best direction.

C-SS

AFTERNOON



Side element with central glass



Aluminium top profile



Base wood-glass junction





Internal corner junction



Internal service element and monitor hatch



7.00 μm

The work is done and everybody is gone.
No more voices, no more annoying rings, no more hectic
actions and gestures. The day is almost over, sounds
and noises are now at peace. Everything is tidy and the
outside blends with the inside, and lights are turned into
shadows.

C-SS

EVENING



Sliding door with round-section handle



Sliding door and upright



Switches mounted on door upright

Aluminium upper corner





Aluminium base profile

12.00 μm

When the night brings deep thinking and we need a welcoming shelter. A place where different materials concur to evoke memories, emotions, and quiet actions. Everything becomes more intimate and human, and we let go, we let the mind find its balance and ideas become creative.

W-SS

NIGHT





Solid wood handle

Matching and mixed partitions





Flush junction



Solid-glass corner

24 hours

Shelters are not needed now, no need for seclusion, silence and concentration are already there. Sounds and noise can fade away with slight corrections and adequate absorption. Functions change, every space gets crowded and listening is not easy.

WALL AND CEILING PANELS

HOUR AFTER HOUR



Wall-mounted soundproofing panels



Aluminium frame



Corrugated soundproofing panels





Suspended panels

Ceiling corrugated panels, fixed or suspended

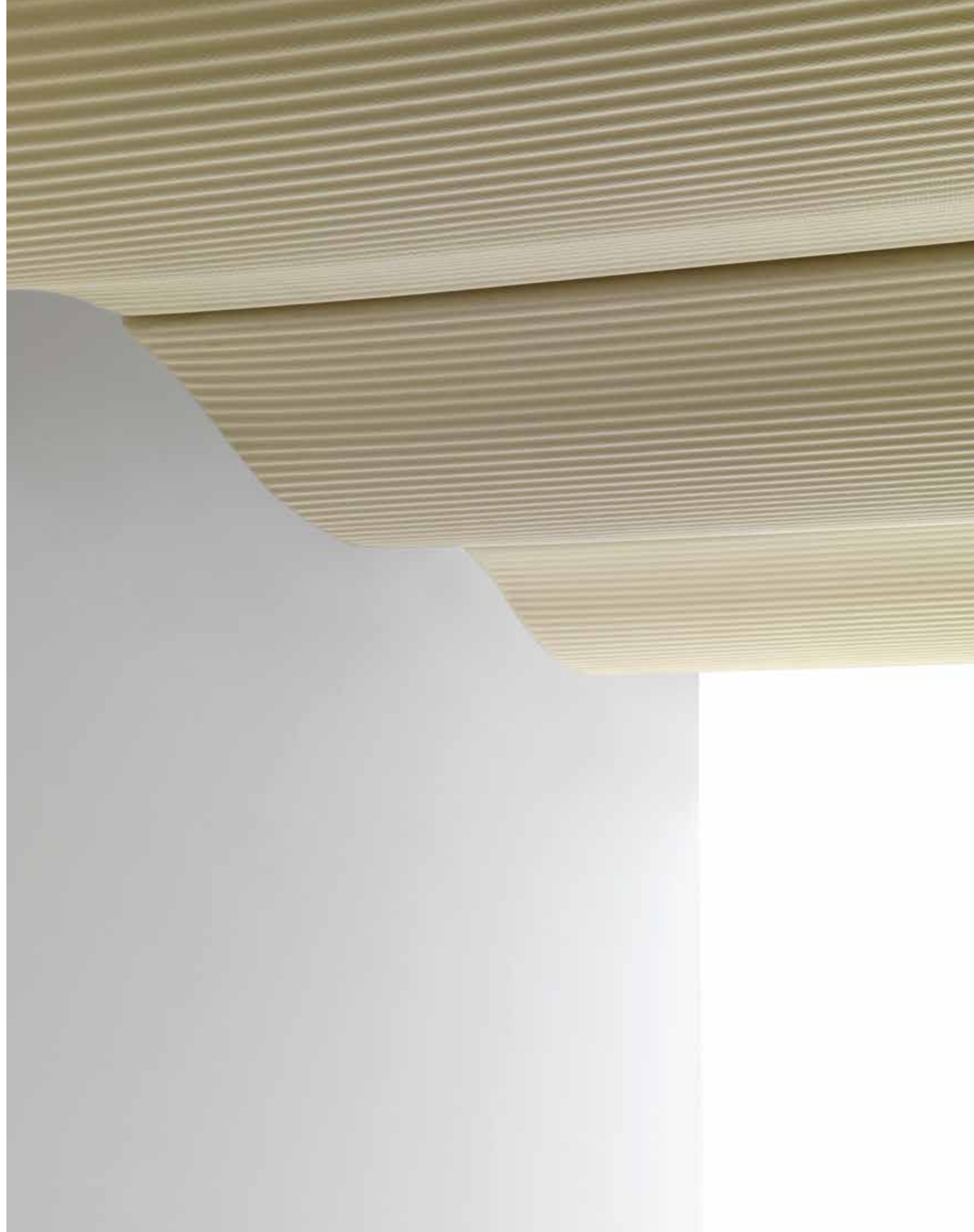

When elements are light and versatile and can be moved to different places. Screens used to shape spaces, to define functions and paths, to close and open, to conceal and to improve listening. When we need to find protection from something or someone, in an ever-changing scenario.

ISLANDS

HOUR AFTER HOUR





185-cm-high elements



Rounded corners

Free-standing acoustic panels, 3 height options



Stabilizer foot



End element



the finishes

ALUMINIUM

A01
Natural anodized



A02
Painted



GLASS

V01

Extra-clear



V02

Clear



MELAMINE

N69

Ice white

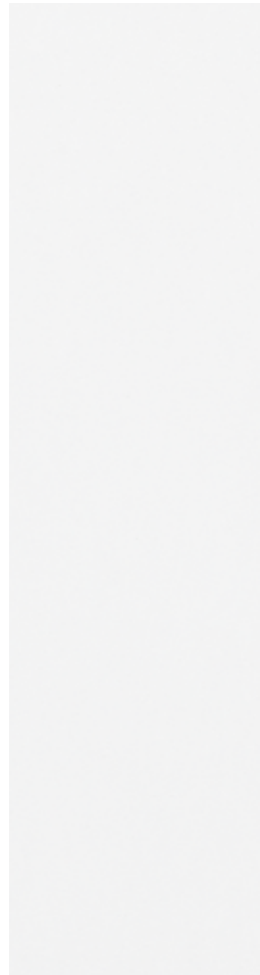

N68

Pure white

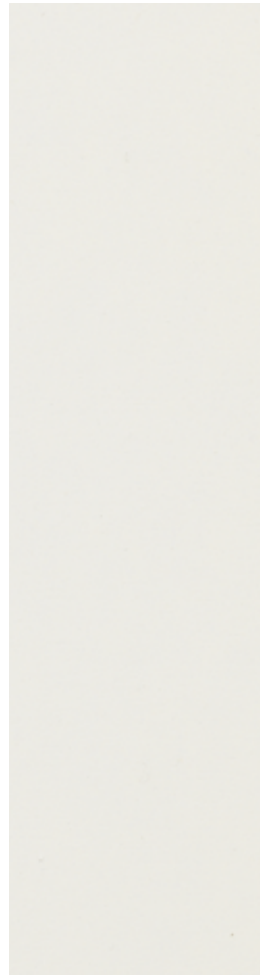

N65

Sahara grey



N66

Line grey



N67

Grigio carbon/
Carbon grey



N64

Acero natural/
Natural maple



N60

Rovere light/
Light oak



N62

Frassino brown/
Brown ash



N61

Rovere dark/
Dark oak



N63

Larice titanium/
Titanium larix

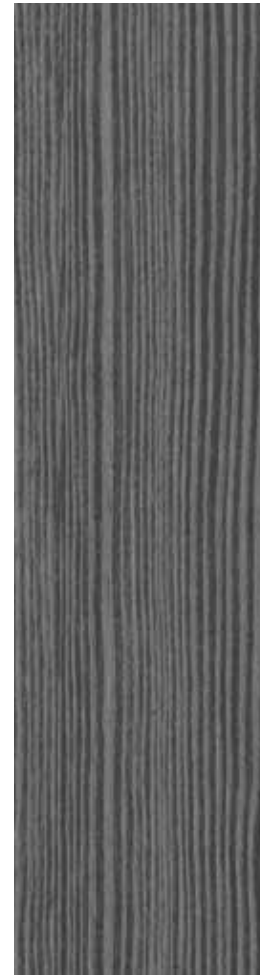

FABRICS



T114
Mandarino/
Mandarin

T115
Arancione/
Orange

T101
Rosso vivo/
Red

T111
Verde acido/
Acid green

T112
Verde/
Green

T113
Giallo limone/
Yellow lemon

T108

Beige



T109

Sand



T110

Walnut

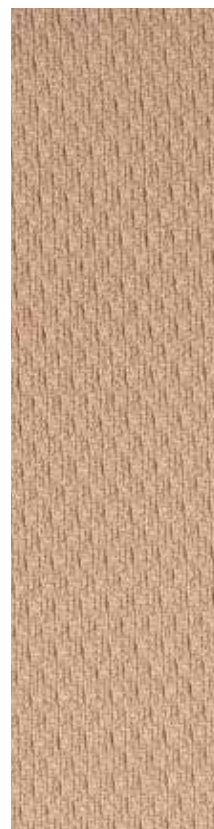

T103

Pearl grey



T104

Ash grey



T105

Grafite/
Graphite



T106
Avio/
Avio



T116
Azzurro cielo/
Blue sky

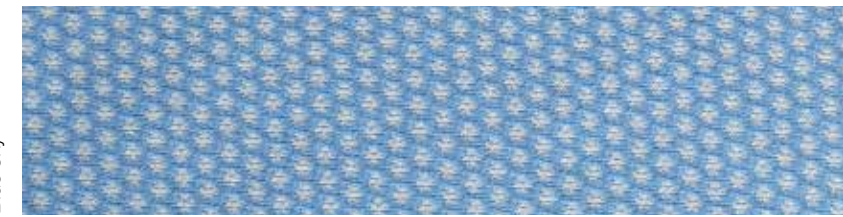

T107
Blu/
Blue



