

**TRUXTA**<sup>4x4</sup> BENDie



The Future of  
Powered and Mini Dumpers



BENDie 300

BENDie 450

# BENDie powered mini dumper

Tufftruk Limited introduce a range of TRUXTA powered mini dumpers that provide maximum versatility and light touch operation, available with battery power, petrol or diesel.

The new BENDie 4x4 mini dumper provides access even in the tightest corners. The TRUXTA 4x4 is really compact and gets into places other units can't.

A BENDie mini dumper's articulated chassis means the TRUXTA handles corners with minimum effort - just steer around bends and corners - no need to lift or reposition.

With a massive skip capacity the TRUXTA BENDie mini dumper offers excellent load capacity in and around sites and gardens.

The well balanced robust unit fits through typical doorways (2ft 6" B300 or 3ft B450). Easily transportable from site to site, and compact enough to store.

**300 BENDie** - 300kg (660lbs) payload, articulated

**450 BENDie** - 450kg (990lbs) payload, articulated



## TRUXTA well balanced for ease of use

**In Operation** -The key factor is that operators don't have to rely on physical strength or brute force with the BENDie's easy steer handling.

The **squeeze & go** controls (no mechanical gearboxes) make for the easiest use for any operator, weak or strong. A fail-safe dead-man braking system keeps the operator safe at all times. Even when tipping the 2 stage self- tip provides optimum balance even with a full load.

## TRUXTA Attachments

TRUXTA has easy fit attachments for a variety of applications. The new TRUXTA Flatbed, folds down and tips up. The towball attachment offers different positions for different sizes of trailer.







- It's the patented '**steering pivot drive system**' that provides ultimate manoeuvrability in a compact size. Combine this with a massive 300kg (660lbs) or 450kg (990lbs) skip capacity and flotation tyres fitted as standard.
- Robust heavy duty construction and a **well balanced skip** means the TRUXTA is built for all sorts of materials and tough terrains.
- **The fail-safe dead-man brake system** and intuitive hydrostatic controls gives the TRUXTA operator the safest possible operation.
- **Easy access** to the fuel filler cap and daily check areas for servicing.
- Uniquely available as a **battery powered option** operators get a quiet environmentally friendly option for the garden or domestic application.



## TRUXTA Hydrostatic Controls

With the TRUXTA petrol, diesel and electric you get a smooth operation with **squeeze & go** hydrostatic system.

TRUXTA mini dumpers - built for durability - hydrostatic system - no slipping belts - sealed for life and maintenance free.

The TRUXTA - 2 stage self-tipping skip requires no manual lifting. The ultimate Skip Tip Angle **equals** no leftovers, just a Totally Empty Skip.

The TRUXTA electric has a regenerative-braking system to help the slow down when stopping; this generates power into battery pack, to increase efficiency and range.



# TRUXTA<sup>4x4</sup> BENDie

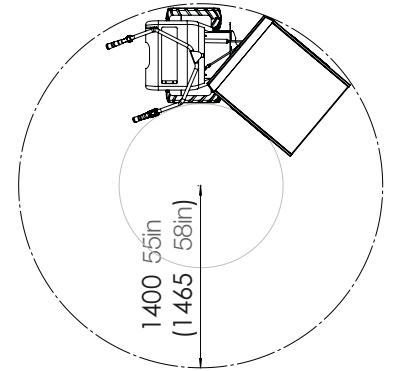
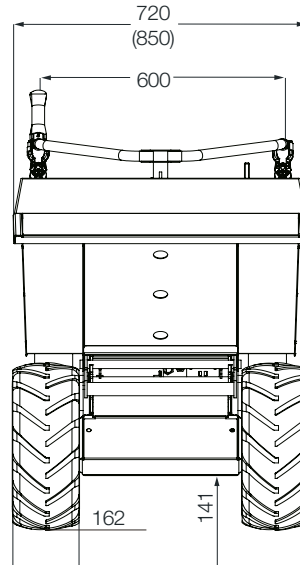
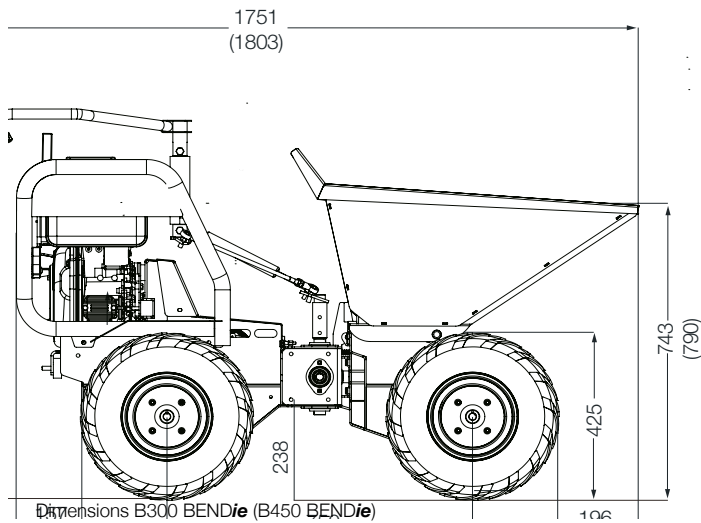

Turning Circle

Dimensions B300 BENDie (B450 BENDie)

## Specifications

B300 BENDie				B450 BENDie					
Model	Petrol TB 300G	Diesel TB 300D	Electric TB 300E	Model	Petrol TB 450G	Diesel TB 450D	Electric TB 450E		
Engine/Motor/Power (kW)/hp	Honda GX 160 (3.6) 4.8	Yanmar L48 (3.5) 4.7	DC Brushless Motor 1000W/24v	Engine/Motor/Power (kW)/hp	Honda GX 200 (4.1) 5.5	Yanmar L48 (3.5) 4.7	DC Brushless Motor 1300W/24v		
Fuel Type	Unleaded Petrol (4 stroke)	Diesel	2 x 12v AGM Batteries	Fuel Type	Unleaded Petrol (4 stroke)	Diesel	2 x 12v AGM Batteries		
Fuel Capacity	Litres	3.1	2.5	Fuel Capacity	Litres	3.1	2.5		
	Gals	0.682	0.55		Gals	0.682	0.55		
Max Payload	300kg/660lbs / 7ft <sup>3</sup> / 0.2m <sup>3</sup>			Max Payload	450kg/990lbs 10.6ft <sup>3</sup> / 0.3m <sup>3</sup>				
Unladen Weight	kg	170	201	224	Unladen Weight	kg	180	219	255
	lbs	374	442	493		lbs	396	482	561
Working Gradient	25°	25°	25°	Working Gradient	25°	25°	25°		
Drive & Controls	Hydrostatic System		24v Motor Gearbox	Drive & Controls	Hydrostatic System		24v Motor Gearbox		
Brake System	Hydrostatic brake system with fail-safe dead-man handle			Brake System	Hydrostatic brake system with fail-safe dead-man handle				
Standard Fitment Tyres	Flotation with option for turf tyres			Standard Fitment Tyres	Flotation with option for turf tyres				
Forward Travel	0-4 mph / 6.444 kph		0-3.5 mph / 5.63 kph	Forward Travel	0-4 mph / 6.444 kph		0-3.5 mph / 5.63 kph		
Reverse Travel	0-1.5 mph / 2.42 kph		0-1.5 mph 2.42 kph	Reverse Travel	0-1.5 mph / 2.42 kph		0-1.5 mph 2.42 kph		
Noise Level (db)	< 96	< 100	< 69	Noise Level	< 96	< 100	< 69		
Hand Arm Vibration	3.6 m/s <sup>2</sup>	3.8 m/s <sup>2</sup>	2.5 m/s <sup>2</sup>	Hand Arm Vibration	4.6 m/s <sup>2</sup>	3.8 m/s <sup>2</sup>	2.5 m/s <sup>2</sup>		

A 12 month warranty is applicable on all Tufftruk machines.

We reserve the right to change specification without prior notice.

10/2017

For more information  
call us direct, or contact:



# TRUXTA<sup>4x4</sup>

Manufactured by Tufftruk Limited in Great Britain

Sales Enquiries Southern Areas **T:** 01666 500123  
**E:** [truxtasales@tufftruk.co.uk](mailto:truxtasales@tufftruk.co.uk) [www.truxta.com](http://www.truxta.com)

Sales Enquiries Northern Areas & International  
**T:** +(44) 01298 84687 **E:** [sales@tufftruk.co.uk](mailto:sales@tufftruk.co.uk) [www.truxta.com](http://www.truxta.com)

Tufftruk Limited, Trading as TRUXTA  
The Croft, Sheen, Nr. Buxton, Derbyshire SK17 0EU