

Electrical Metals & Components



Earthing Equipment



Earthing Equipment for:
Power Stations
Sub Stations
Overhead Power

Earthing Equipment for:

Power Stations, Sub Stations, Overhead Power.



Electrical Metals & Components

 **Alcomet**

Earthing Equipment

As an endorsement of quality and excellence, HM Queen Elizabeth II honoured Alcomet with a Queens Award for Enterprise: Innovation, expressly for the development and launch of the Guardian Security Range.

Alcomet has continued to work with the electrical market and responded to its needs by developing products such as the Triton Portable earthing device and expanding our stock range available on demand.

Alcomet is an official distributor of the P & B Weir range of Portable Earthing Equipment.

Since the acquisition of the Weir Electrical Instrument Co. Ltd. in 1992, P&B Weir Electrical has established itself as one of the leading manufacturers of Portable Earthing Equipment for use on Overhead Lines and in Sub-Stations at both Transmission and Distribution voltages.



Earthing Equipment

Contents

Section 1 Portable earthing equipment for substations	05
Section 2 Portable Earthing Equipment for overhead lines	11
Section 3 Fixed Earthing Devices for Substations	17
Section 4 General Purpose Earthing Equipment	20
Section 5 Portable Earthing Equipment for Electro-static Precipitators	30

SECTION 1

Portable Earthing Equipment for Substations



This portable earthing equipment is specifically for maintenance on outdoor high voltage substations.

It has been designed to provide safe and sure clamping where certain connections are to be made on dirty or heavily oxidized copper/aluminium bars or stubs and in other cases to meet the requirements for the modern 132,275 and 400kV substations having tubular aluminium connection diameters 90mm, 102mm, 140mm, 160mm and 200mm.

In their respective applications the clamps, operating poles, sockets and cables have safely withstood their respective Mechanical Type Tests and/or Short Time Current Type Tests specified in ESI 41-21 Section 5.

SECTION 1

Portable Earthing Equipment for Substations *continued*

1. Scope

The complete range, capabilities and details of this equipment will be identified and illustrated in Figs 1 to 17 inclusive

2. Design & Construction

All the equipment illustrated is designed to meet the specific requirements of ESI 41-21. The construction is of a robust nature and will withstand a reasonable amount of rough handling.

3. Equipment

3.1 – Earth End Clamps

The spring loaded feature of all types makes them suitable for application by hand to copper or aluminium earth bars in any natural condition. (See paragraph 5.1)

3.2 – Line End Clamps

All types whether spring loaded or not should be applied by means of an operating socket (See paragraph 5.2) attached to an insulated operating pole. The design of all Line End Clamps is such that once hooked over a busbar they become self supporting whilst the operating screw is tightened or loosened.

3.3 – Stranded Conductors – Line End Clamp

It may be necessary in some older substations to apply earths to dirty stranded conductors. However, small diameter stranded conductors may not carry the full rated current, but tests have shown that Clamp Type ESI-L1 successfully carried 13.1 kA (750 MVA at 33 kV) for 2 seconds when attached to a 200 sq. mm in polluted hard-drawn copper stranded conductor.

3.4 – Operating Sockets

Made in light alloy material, the two types are illustrated in Figs 15 and 16. These essentially support the Line End Clamp when being carried at the end of an operating pole and also actuate the operating screw of the Line End clamp when being secured in position or being removed. Socket type S9D ESI S1 (Fig. 15) supports clamps being applied in an upward direction. Socket type CEA/S ESI S2 (Fig. 16) is an alternative type to the above where the operating screw of the Line End Clamp is controlled by means of spring loading enclosed in the socket.

3.5 – Operating Poles – Insulated

These should be limited to a length of 4.88m (16ft) as it is considered that this is the maximum length of pole with clamp and lead attached which can normally be handled with

safety. Poles of these lengths are made up in multiple sections of 1.22m (4ft) lengths (See Fig.17) the joints are machined to provide a rigid assembly and include a double sided snap action spring locking device. All details are in accordance with Specification ESI 41-21.

3.6 – Earth Leads

Only cables from approved manufacturers and terminations with approved compression end and support springs in accordance with Specification ESI 41-21 Paragraph 6.1, are supplied for earthing leads for connecting between the Line End Clamps and the Earth End Clamps. The flexible conductor is of circular cross section made up of commercially pure aluminium wires in the H68 (BS2627) condition giving a nominal sectional area of 150mm². The nominal number and nominal diameter of wires is 925/0.45mm. The conductor is laid up as 37 stranded ropes each of 25 bunched wires in 3 layers applied in the same direction of lay around a central rope. The lengths of lay for the inner, middle and outer layers are approximately 75, 125 and 175mm respectively. The conductor has a nominal diameter of 17.2mm with a maximum of 17.9mm. the conductor is wrapped with a layer of 0.023mm p.t.p tape with a maximum overlap of 25 per cent. The conductor then has an extruded p.v.c sheath of approximately 1.25mm radial thickness applied to protect the conductor from corrosion and mechanical damage. The diameter over the p.v.c sheath of the cable does not exceed 20.5mm. The conductor resistance per 1000m at 20°C does not exceed 0.208 ohms.

4. Selection of Clamps and Cables

4.1 – Current Rating

Portable earthing equipment for use in open type H.V. substations consists of Line End Clamps, Earth End Clamps, Earth Leads, Operating Poles and Operating Sockets. These components are suitable for assembly into sets of earthing equipment and the minimum current/time rating of one set is 17.5 kA RMS for 2 seconds except that when applied to a 10mm diameter line conductor the minimum current rating of the conductor/equipment combination is 13.1kA for 2 seconds. The Clamps are suitable for application to existing Line and Earth End conductors of the sizes specified. One set of earthing equipment, which complies with the specified weight limitations, is the maximum

which can be safely applied by a person of average strength. At locations where the fault current level exceeds the specified current/time rating of 17.5 kA for 2 seconds it is intended that more than one set of equipment be used. It should be noted that with solidly earthed neutrals the single phase fault current can be up to 1.2 times the three phase fault current.

4.2 – Guide to Suitable Number of Leads

Prospective Single Phase Symmetrical Fault Current	Number of Leads
17.5 kA 1	
31.5 kA 2	
47.25 kA 3	
63 kA 4	

4.3 – Earthing Equipment subjected to Fault Current in Service

Should earthing equipment inadvertently carry a short circuit current it must be discarded as there is no satisfactory way of assessing its suitability for further service.

5. Application of Earths

5.1 – Earth End Clamps

When manually applying and removing these clamps only firm pressure by a person of normal strength is necessary to achieve good contact and tightness. Spring loaded clamps should be tightened down until the spring is fully compressed. Earth End Clamps should be fastened securely in place before any attempt is made to secure the Line End Clamp.

5.2 – Line End Clamp – S9D

Operating Socket Only When a clamp is raised to the busbar a locating lug on the clamp engages with a short slot in the top of the socket. As soon as the clamp is pulled down over the busbar the lug is disengaged allowing the socket to turn, whilst the cross pin in its operating screw is retained within a long slot in the socket. The special contour of this long slot is such as to give a fully positive tightening action whilst making it virtually impossible for the clamp to become inadvertently disengaged from the pole. It should be noted that at all times when tightening or loosening a clamp a downward pull should be maintained on the pole. When the clamp is fully tightened the socket should be pushed gently up towards the clamp by 6.35mm (0.25in) at

the same time maintaining the tightening pressure and the socket will automatically become disengaged. For attachment, the operating pole should be rotated with normal firm hand pressure until a definite resistance to further movement is experienced. At this point spring loaded line end clamps will be positively tightened and the spring fully compressed.

5.3 – Line End Clamp – CEA/S Socket Only

This socket is for application in the downward direction, i.e., below the horizontal, and for this reason is spring loaded to ensure the clamp does not fall out of the socket inadvertently.

6. Maintenance of Earthing Equipment

It is essential that earthing equipment is handled and stored with care and is properly maintained. The equipment should be inspected at maximum intervals of 3 months and immediately prior to application. The results of the regular inspection should be recorded.

Clamps: Should operate freely and moving parts should be lightly lubricated. Springs should be protected by a heavy grease. Contact faces should be clean.

Flexible Cables: There should be no visible damage to strands of cables, and the P.V.C sheath should be sound.

The joint between the cable and termination should be secure and the components must be in good condition. M12 bolts securing cable termination to line end clamps must be tightened by applying a torque of 61 Nm.

Poles: Should be inspected for damage which could lead to breakage of the pole when lifting earthing equipment. Joints between pole sections and socket must be in a sound condition.

Poles should be cleaned and revarnished at appropriate intervals.

Acknowledgement is due to the Electricity Supply Industry for permission to refer to and quote from ESI Standard 41-21.

SECTION 1

Portable Earthing Equipment for Substations continued



Earth End Clamps CE20/ESI-E1

Fig. 1 CODE CE20/ESI-E1

Earth End Clamp

For application to clean or dirty copper or aluminium strip.

Maximum thickness 6.5mm

Minimum thickness 3.2mm

Maximum width 50mm

Minimum width 38mm

Provision for attachment of one flexible lead as in Fig. 13.

NOTE: When secured the spring shall be fully compressed and this shall be readily visible.

Tested to 38kA for 2 secs

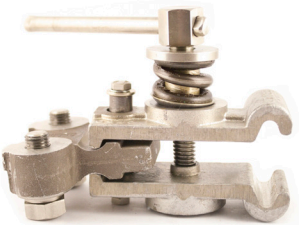
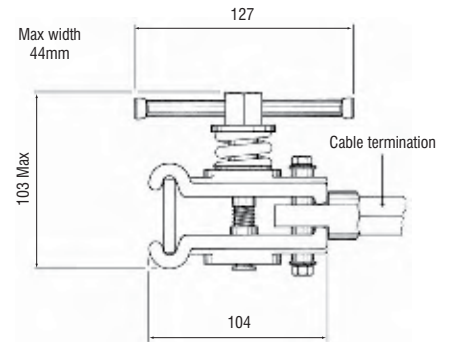

Earth End Clamp CE20/2

Fig. 2 CE20/2 Earth End Clamp

Designed initially for use with mechanical aids to the application of portable earths, also readily compatible for use in portable earthing applications.

Maximum thickness 6.5mm

Minimum thickness 3.2mm

Maximum width 50mm

Minimum width 38mm

Provision for attachment of two flexible lead as in Fig. 13.

NOTE: When secured the spring shall be fully compressed and this shall be readily visible.

Tested to 38kA for 2 secs

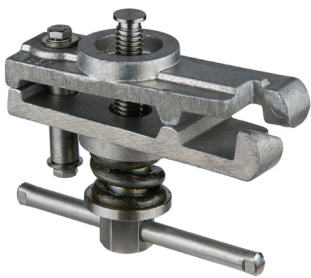
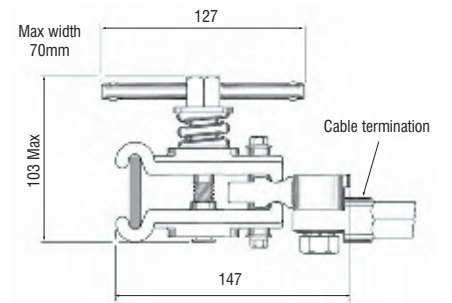

Earth End Clamp CE21

Fig. 3 CE21 Earth End Clamp

For application to clean or dirty copper or aluminium strip.

Maximum thickness 13mm

Minimum thickness 3.2mm

Maximum width 50mm

Minimum width 25mm

Provision for attachment of one flexible lead as in Fig. 13.

NOTE: When secured the spring shall be fully compressed and this shall be readily visible.

Tested to 17.5kA for 2 secs

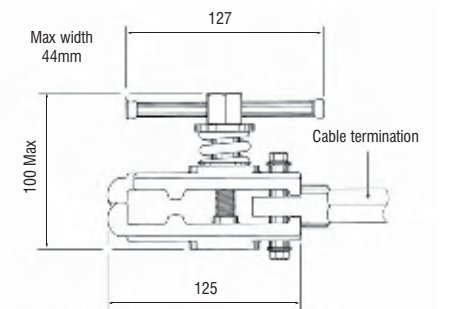

Earth End Clamp CE22A/ESI-L1

Fig. 4 CODE CE22A/ESI-L1

Line End Clamp

For application to clean or dirty copper or aluminium tube, within the range 10-38mm diameter.

Provision for attachment of one flexible lead as in Fig. 13.

NOTE: For attachment the operating pole should be rotated with normal firm hand pressure until a definite resistance to further movement is experienced.

Tested to 17.5kA for 2 secs

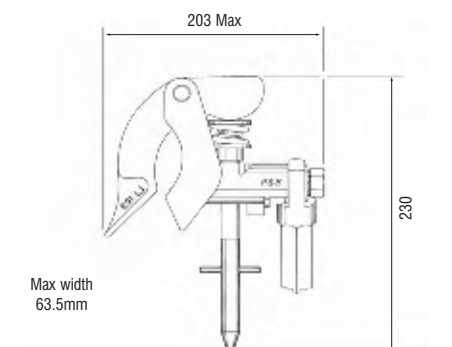

All sizes are in millimetres unless otherwise stated

SECTION 1

Portable Earthing Equipment for Substations continued



Line End Clamp CE22B/ESI-L2

Fig. 5 CODE CE22B/ESI-L2

Line End Clamp

For application to clean or dirty copper or aluminium tube, within the range: 38-76mm diameter.

Provision for attachment of one flexible lead as in Fig. 13.

NOTE: For attachment the operating pole should be rotated with normal firm hand pressure until a definite resistance to further movement is experienced.

Tested to 17.5kA for 2 secs

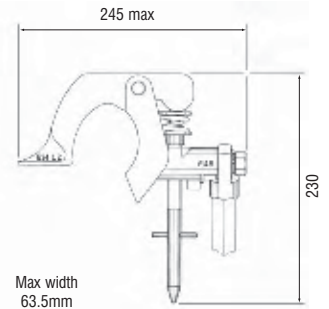

Line End Clamp CE22C/ESI-L3

Fig. 6 CODE CE22C/ESI-L3

Line End Clamp

For application to clean or dirty copper or aluminium tube, within the range: 60-90mm diameter.

Provision for attachment of one flexible lead as in Fig. 13.

NOTE: For attachment the operating pole should be rotated with normal firm hand pressure until a definite resistance to further movement is experienced.

Tested to 17.5kA for 2 secs

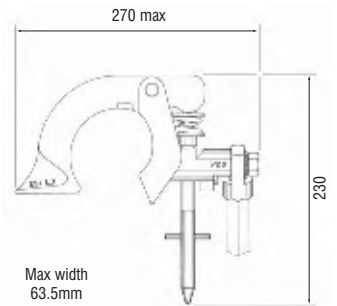

Line End Clamp CE22 A+B

Fig. 7 CODE CE22 A+B

Line End Clamp

For application to clean or dirty copper or aluminium tube, within the range: 19-76mm diameter.

Provision for attachment of one flexible lead as in Fig. 13.

NOTE: For attachment the operating pole should be rotated with normal firm hand pressure until a definite resistance to further movement is experienced.

Tested to 17.5kA for 2 secs

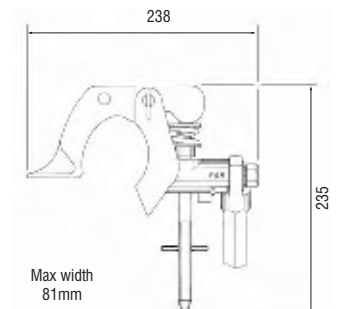

CE16/5/ESI-L4

Fig. 8 CE16/5/ESI-L4

For application to aluminium tube 127mm diameter only.

Provisions for attachment of three flexible leads as in Fig. 13.

Tested to 50kA for 3 secs

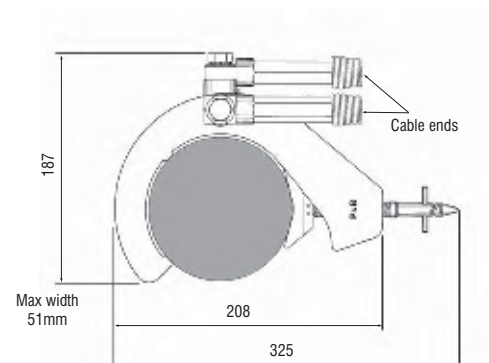

All sizes are in millimetres unless otherwise stated

SECTION 1

Portable Earthing Equipment for Substations continued



CE16/5.5/ESI-L5

Fig. 9 CE16/5.5/ESI-L5

For application to aluminium tube 140mm diameter only.
Provisions for attachment of three flexible leads as in Fig. 13.

Tested to 50kA for 3 secs

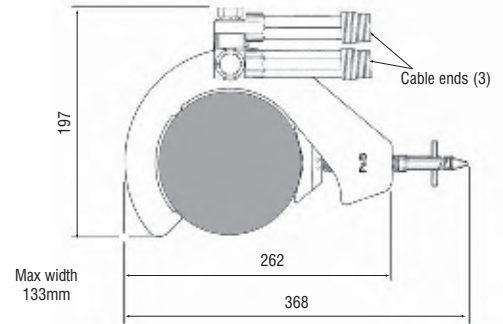

CE25

50/2 Line End Clamp (Mechanical Aid)

Designed specifically for use with mechanical aids to the application of portable earths and to permit the raising of two earthing leads.
For application to clean or dirty copper or aluminium tube.
Maximum diameter 75mm
Minimum diameter 35mm
Provision for attachment of two flexible lead as in Fig. 13.

NOTE: For attachment the operating pole should be rotated with normal firm hand pressure until a definite resistance to further movement is experienced.

Tested to 38kA for 2 secs

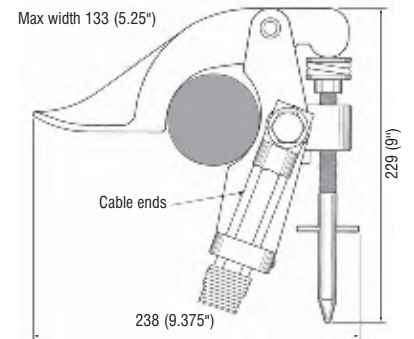

CE50 & CE51

Fig. 11 CE50 & CE51

CE50 for application to aluminium tube 190 to 200mm diameter and.
Provisions for CE51 for application to clean or dirty aluminium tube 140 to 160mm diameter Provision for attachment of two flexible leads as in Fig. 13.

Tested to 38kA for 2 secs

Clamp	X	Y	Z
CE50	269	348	493
CE51	240	310	455

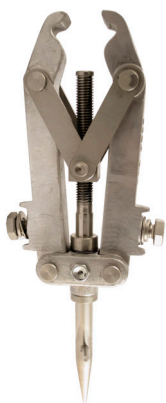
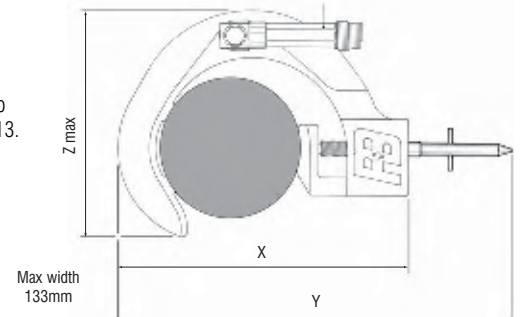

CE57

Fig. 12 CE57 Earth Tape Clamp

For application to damaged aluminium or copper earth tapes in a clean or dirty condition, ranging from 25 x 3mm to 100 x 6mm.
Providing a drain earth before fitting a bridging earth suitable for fault protection.

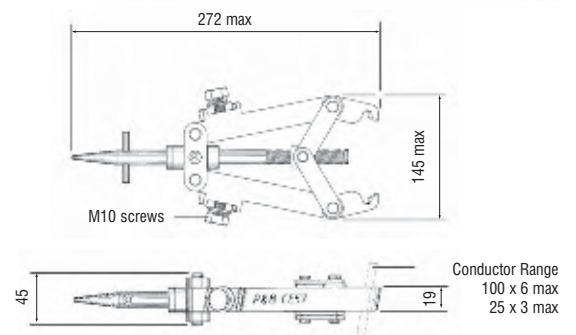

All sizes are in millimetres unless otherwise stated

SECTION 1

Portable Earthing Equipment for Substations continued



Earthing Lead ESI-C1-2T1

Fig. 13 CODE ESI-C1-2T1

Earthing Lead

To be terminated only with terminations as Fig 14.
For attachment to earth end and line end clamps as in Figs 1 to 11 inclusive.

Tested to 17.5kA for 2 secs

Length as required.

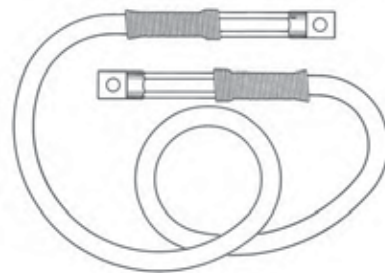

ESI/T1

Fig. 14 CODE ESI-T1

Compression Termination to suit 150mm² Aluflex.
Compress to 22.73 A/Fx 76.2mm Bite Length.



Operating Socket S9D:ESI-S1

Fig. 15 S9D:ESI-S1

For attachment to glass fibre operating pole as in Fig. 17
and application of line end clamps as in Fig. 4 to 11 inclusive.



Operating Socket CEA/S:ESI-S2

Fig. 16 CEA/S:ESI-S2 Operating Socket

For attachment in glass fibre operating pole as Fig. 11 and application of line
end clamps as in Fig. 4 to 11 inclusive.

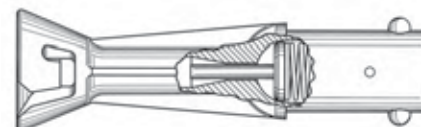

All sizes are in millimetres unless otherwise stated

SECTION 1

Portable Earthing Equipment for Substations continued

Operating Poles ESI-P1

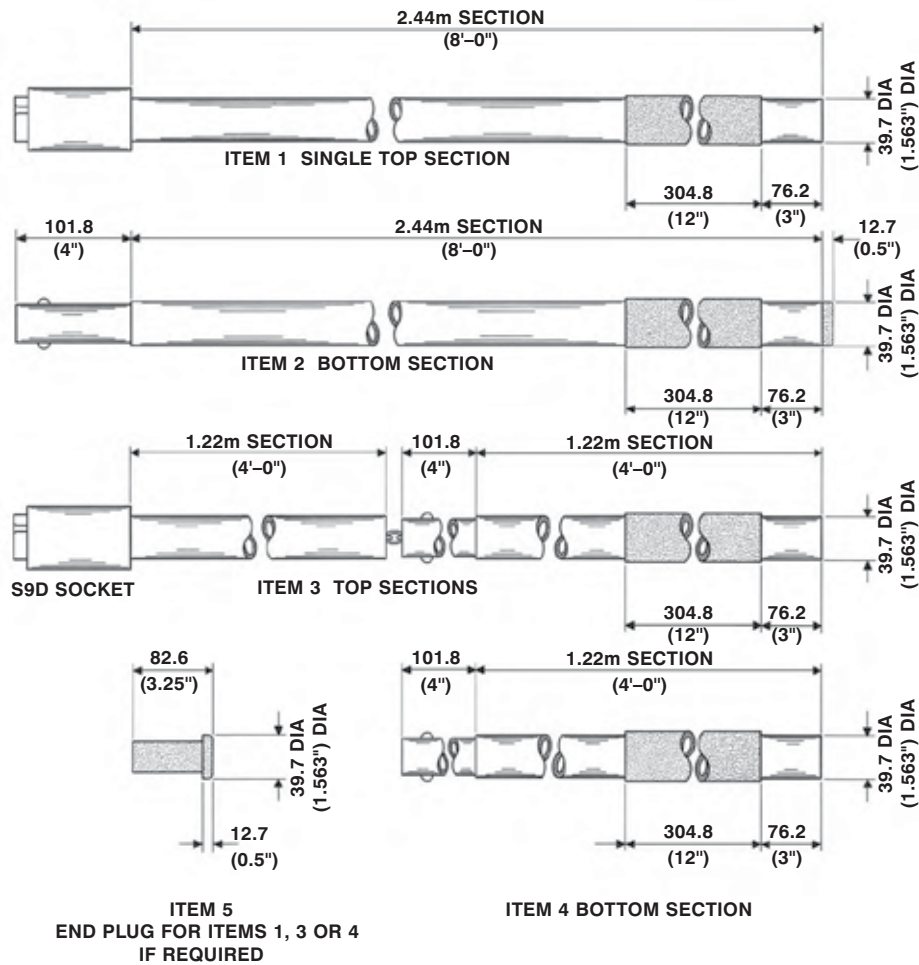

Fig. 17 CODE ESI-P1 Operating Poles

Earthing poles should be limited to a maximum length of 16ft (4.88m) and may be made up in either of the following alternatives

ALTERNATIVE 'A':

Top – Item 1 – 8ft (2.44m) long single section

Bottom – Item 2 – 8ft (2.44m) long single section with end plug, item 5.

ALTERNATIVE 'B'

Top – Item 1 – 8ft (2.44m) long in 2 x 4ft (1.22m) long sections permanently joined by a chain.

Intermediate or Bottom – Item 4 – 4ft (1.22m) long.

End Plug – Item 5 – only supplied when specified on order.

All sizes are in millimetres unless otherwise stated

SECTION 2

Portable Earthing Equipment for Overhead Lines



This equipment is specifically portable earthing for use on 132, 275 and 400kV overhead line conductors during erection and maintenance work.

It is designed to be as light as possible, employing aluminium alloy clamps, aluminium earthing leads and glass fibre operating poles. These have been developed in conjunction with The National Grid Company Limited and are currently included in their Standard 43921 TPS 1/113 (Overhead Lines), or NS14 (Work on High Voltage Overhead Lines).

SECTION 2

Portable Earthing Equipment for Overhead Lines continued

1. Scope

The complete range, and details of this equipment will be identified and illustrated in Figs. 1 to 14 inclusive, at the end of section 2.

2. Design & Construction

All clamps are designed with an ultimate strength well in excess of normal working loads, and all designs are type tested at normal loading before being approved for production. The construction of all equipment is of a robust nature and will withstand a reasonable amount of rough handling.

3. Equipment

3.1 Earth End Clamp

Code CE10/A2 (Standard) Fig.1

For direct application by hand to tower steelwork. The large thumb screw of this device has a captive hardened steel tip which penetrates through painted, weathered or non conductive surfaces and indents into steel work ensuring a strong efficient connection to earth.

3.2 Earth End Clamp

Code CE18/A (Bridging) Fig. 2

For earthing line conductor over tension set insulators to tower arm coupling during maintenance, bolts to coupling through

clearance hole for arcing horn bolt which is removed prior to earthing.

3.3 Line End Clamp

Code CE52/A (Normal Type) Fig. 3

Intended to be applied only by means of an operating socket attached to an insulated operating pole in either upward or downward direction. Spring loaded jaws enable clamp to be slipped easily over the line conductor and retains clamp in position whilst operating screw is being tightened/loosened.

3.4 Line End Clamp

Code CE13/A (Angled Type) Fig. 4

As above but designed to be applied in near horizontal position from tower cross arm over tension set insulators to line conductor.

3.5 Line End Clamp Code CE23/A

(Running Earth) Fig. 5

Designed specifically for earthing line conductors during "Stringing" operations. Enables cable to run freely between contact roller faces whilst providing a positive contact to earth.

3.6 Operating Socket

Code OL1 Fig.10

Made in light alloy material with internal spring loaded plunger which maintains grip

pressure on the inserted operating screw, holding both screw and clamp rigid whilst being directed into position.

3.7 Operating Poles Figs. 12,13,14

Made in strong glass fibre material in accordance with C.E.G.B. Specification 43921. Supplied as single 2.4m (8ft) section complete with operating socket or as 2.4m (8ft) heavy duty telescopic extending to 4.8m (16ft) with two intermediate positive stop positions. Lengths of the telescopic poles can be increased further by use of a single 1.8m (6ft) extension pole, supplied when specified. Carrying slings for telescopic and extension poles can be supplied as optional extra.

3.8 CE60 'Sparrow' Plate Fig 8

Multiple earth tower bonding plate designed for control of induced currents. Manufactured from aluminium alloy and provided with location for up to twelve portable drain earths fitted with PB50F ferrule type terminations. Also provided with bolted connections for up to four interconnecting earth leads. Six thumbscrews with (replaceable) hardened tips for effective bonding to the tower structure are also incorporated.

3.9 CE61 'DEAS' Bar Fig .9

Developed by the National Grid Company as

an earthing bar for use in the arcing horn bolt hole of the earth side insulator string arrangement, when lowering off tension set insulators. Made from aluminium alloy, this equipment may be used in conjunction with CE52/A, CE31/A Line End Clamps, CE10/A1, CE10/A Earth End Clamps and CE18/A Bridging Earth.

3.10 Earthing Leads

Flexible conductors are of commercially pure aluminium wires in the H68 condition. The conductor is wrapped with a layer of P.T.P. tape and covered with an extruded clear P.V.C sheath. Earth End to Line End Clamp interconnecting leads are 50mm² nominal sectional area. These are terminated by PB50F type ferrule terminations. Flexible clear P.V.C stress relieving sleeves are fitted to prevent excessive wear about the compression joints, which can occur due to wind oscillation in service. Earth leads are 120mm² nominal sectional area are terminated by PB120 palm type terminations. Flexible clear P.V.C stress relieving sleeves are fitted to prevent excessive wear about the compression joints.

Earth End Clamp CE10/A2

Fig. 1 CODE CE10/A2

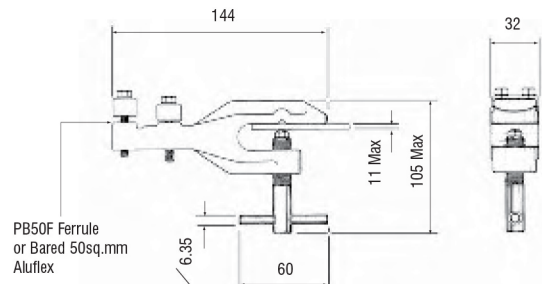
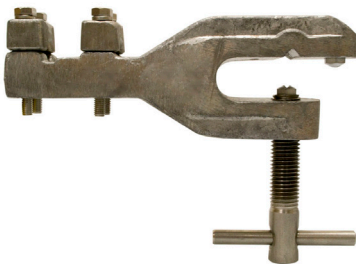

Earthing End Clamp (Bridging)

CE18/A

Fig. 2 CODE CE18/A

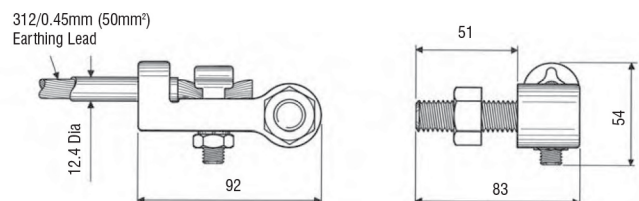

All sizes are in millimetres unless otherwise stated

SECTION 2

Portable Earthing Equipment for Overhead Lines continued

CE13/A
Fig. 15 CODE CE13/A

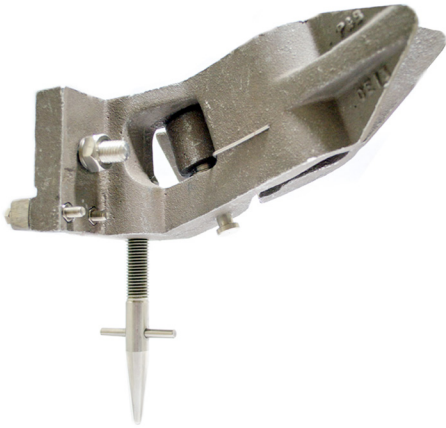

Position 1 19.1 (0.75") Dia
Position 2 28.6 (1.125") Dia

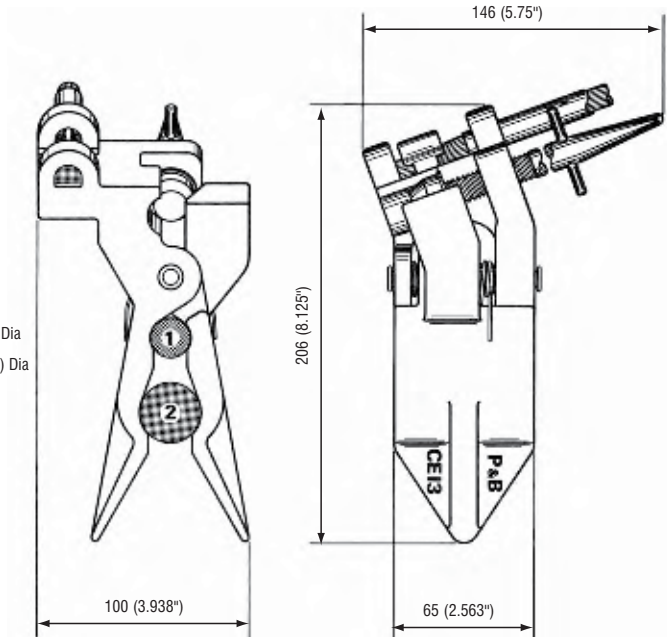

Running Earth CE23/A
Fig. 5 CODE CE23/A

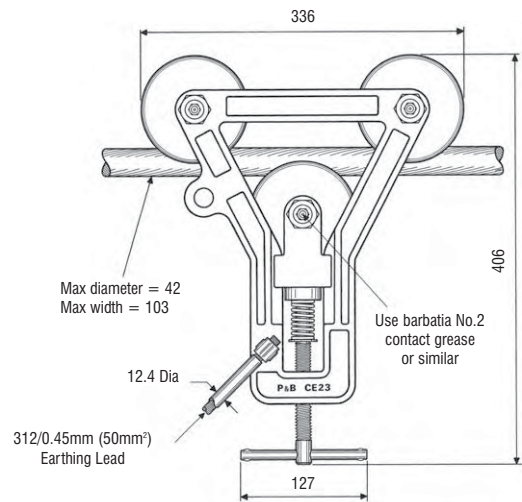
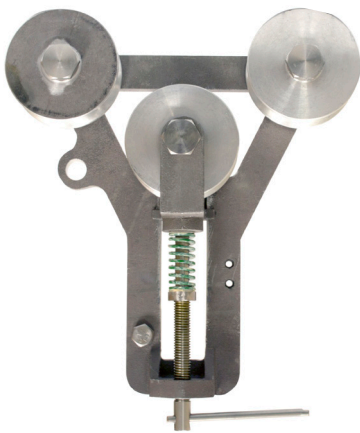

Lug PB50
Fig. 6 CODE PB50
Compression Termination to suit 50mm² Aluflex
Compress to 15.5mm A/F x 30mm Bite Length.



Ferrule PB50F
Fig. 7 CODE PB50F
Ferrule Termination
To suit 50mm² Aluflex
Compress to 15.5mm A/F. Bite Length 35/37mm.

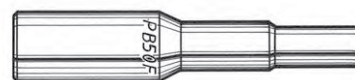

All sizes are in millimetres unless otherwise stated

SECTION 2

Portable Earthing Equipment for Overhead Lines continued

CE69

Fig. 16 CODE CE69

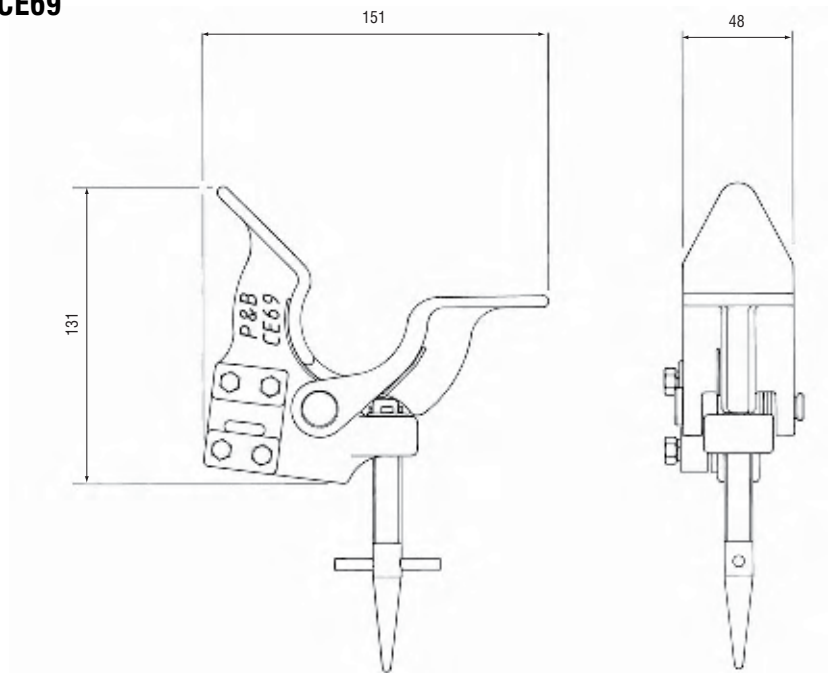
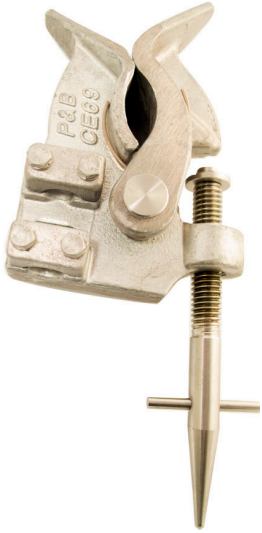

All sizes are in millimetres unless otherwise stated

SECTION 2

Portable Earthing Equipment for Overhead Lines continued

CE60 Sparrow Plate

Fig. 8 CODE CE60

Used to provide a common point of connection for portable drain earths that will permit the safe and effective control of induced currents and voltages.

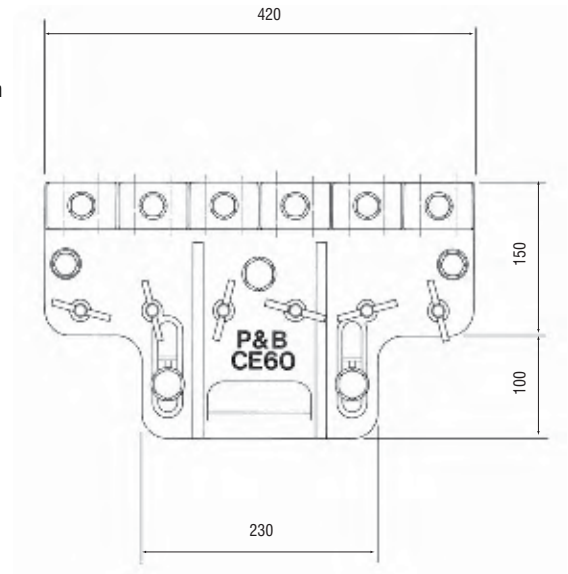
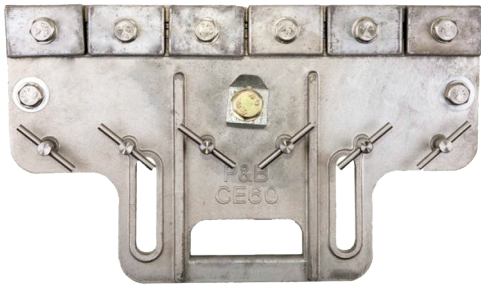

CE61 Deas Bar

Fig. 9 CODE CE61

Used for connecting into the arcing horn landing hole to provide a temporary point of connection for partial bridging earths and drain earths when lowering off a string of insulators.

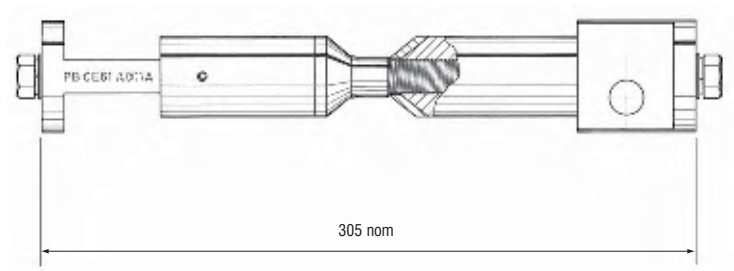

Socket OL1

Fig. 10 CODE OL1

Socket for Operating Clamps with Long Taper Operating Screws.

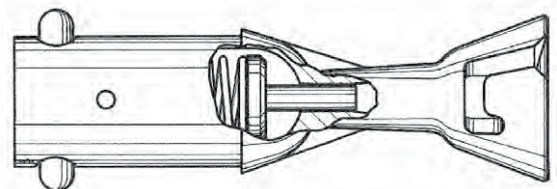

All sizes are in millimetres unless otherwise stated

SECTION 2

Portable Earthing Equipment for Overhead Lines continued

Single Section Pole
Fig. 11

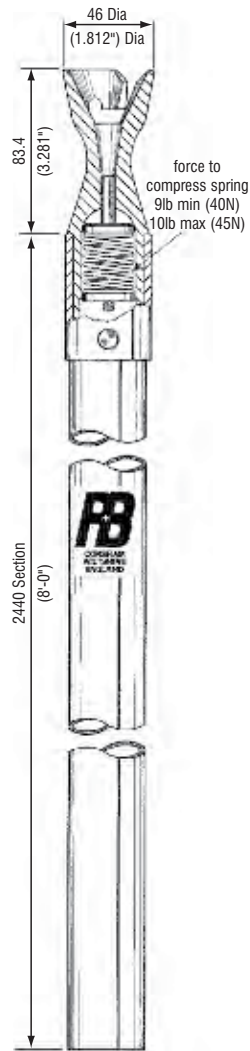

Telescopic Pole
Fig. 12

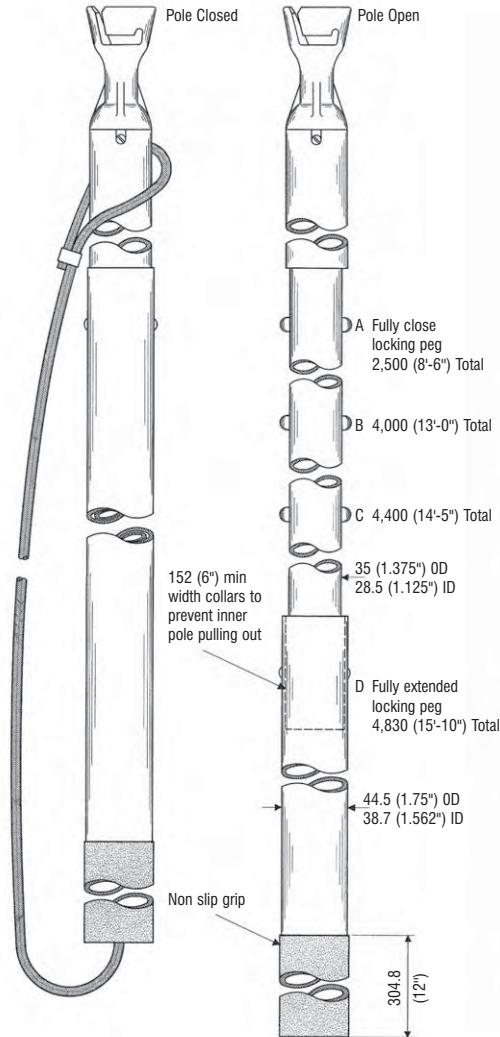

Extension
Fig. 13

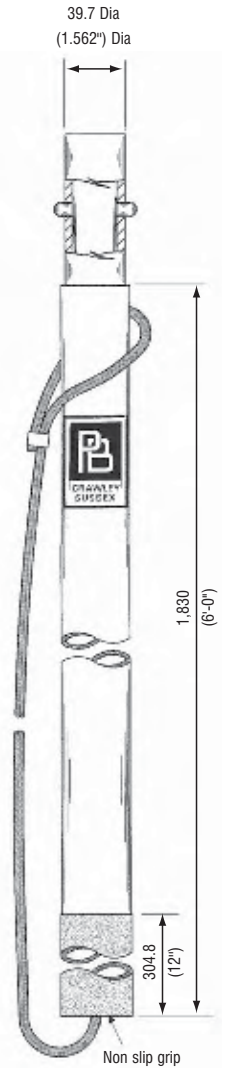

Bridging Earth Pole Fig. 14

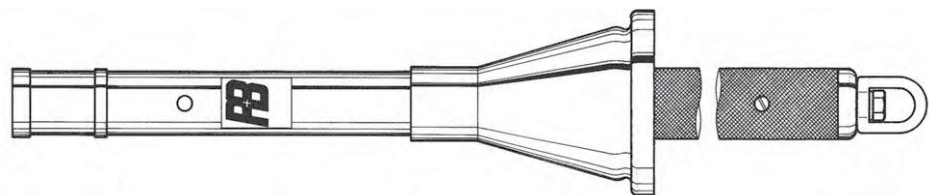

All sizes are in millimetres unless otherwise stated

SECTION 3

Fixed Earthing Devices for Substations



SECTION 3

Fixed Earthing Devices for Substations continued

1. Scope

Acknowledgements

This equipment covers fixed devices for earthing 132kV sub-stations having fault levels up to 5,000 MVA and 275 kV substations having fault levels up to 15,000 MVA. It was designed and developed by P&B in conjunction with the CEGB and is manufactured to the CEGB Standard TPS 3/4 (Switchgear).

Acknowledgement is due to the Electricity Supply Industry for permission to quote from the Standard.

2. Design and Construction

Each earthing device consists of a single phase assembly shown typically in Fig.1 and having the following features: The operating pole is a glass fibre pole located vertically in two or more guides.

The lower guide has a bolt which is normally located in a hole in the pole, thus preventing the pole from being raised. The bolt can be withdrawn only when freed by use of a conventional interlock key or padlock key.

A double hooked line end clamp is permanently attached to the top of the pole.

One or two cables according to rating are permanently attached to the line end clamp and to the nearest earth bar.

A special earth bar clamp has been developed which is suitable for attaching to existing copper earth bars to give a fully rated permanent connection. A hole 8.73 mm diameter (11/32") is required for each clamp. Ensure that the earth bar is clean back and front. If attaching to new earth bar secure aluminium or Copper/aluminium compression terminal direct to clean (tinned in the case of copper) earth bar by 12.7mm (1/2") diameter bolt through 8.73mm diameter hole ensuring that 'shoulder' on fitting is hard against the edge of the earth bar.

The guides are attached to suitable steel adaptors which secure the equipment to convenient parts of structures provided for main equipment. They vary with the nature of the structure and are not supplied by P&B but a range of steel adaptors suitable for most applications is included in CEGB Standard TPS 3/4. Interlock boxes for standard locks with 16mm (5/8") long

stubs are available for single way or three way arrangements. The single way boxes will normally be fitted to two phases and the multi-way box to the third phase. Any number of locks can be added to the multi-way by means of extension boxes. If required the equipment may be installed without interlocks but with provision for padlocking in the "OPEN" position only.

The "lift" of the pole is limited by the distance between the bottom guide and the ground, so that where the initial "lift" is insufficient, one or two extension poles are required. These extensions are of light weight glass fibre with snap action sockets. A simple resting device is available which permits the pole to be supported at suitable locations so that both of the operator's hands are free for fitting and removing extension poles. The line end clamp is suitable for rigid circular conductors or stubs of any diameter between 38 to 76mm (1 1/2" to 3") and is provided with one of three settings as required. The conductor or stub must be substantially horizontal. A series of busbar spigots are available each suitable for a prescribed position where the busbar is not substantially

horizontal or the busbar consists of a stranded conductor. See Section 6. Special attention has been paid to the prevention of accidental or deliberate defeat of the interlocking systems.

All current carrying parts are of copper or copper based alloys. Other metal parts are stainless or galvanised steel. It is not anticipated that there should be any deterioration of the equipment due to being located permanently outdoors but glass fibre poles may require to be re-varnished from time to time.

3. Technical Application

The equipment has been fully tested for the fault ratings to be found on the CEGB's systems. For fully interlocked devices only one cable per phase is required irrespective of the fault level. For padlocked equipment flexible earth leads must be provided according to the rating listed in Table 1.

4. Supply of Components

The components supplied by P&B are as shown in full on Fig. 1. The interlock locks and keys are not included.

Table 1

System Voltage kV	Rated Fault Level Three Phase Symmetrical MVA	Maximum Single Phase Fault Current r.m.s.kA	No. of Cables	Cross Sectional Area of Cable/s Sq. In.
132	2500	11.0	1	0.125
132	3500	15.4	1	0.125
132	5000	26.3	2	0.125
275	7500	15.8	1	0.125
275	15000	31.6	2	0.125

SECTION 3

Fixed Earthing Devices for Substations continued

Fig. 1

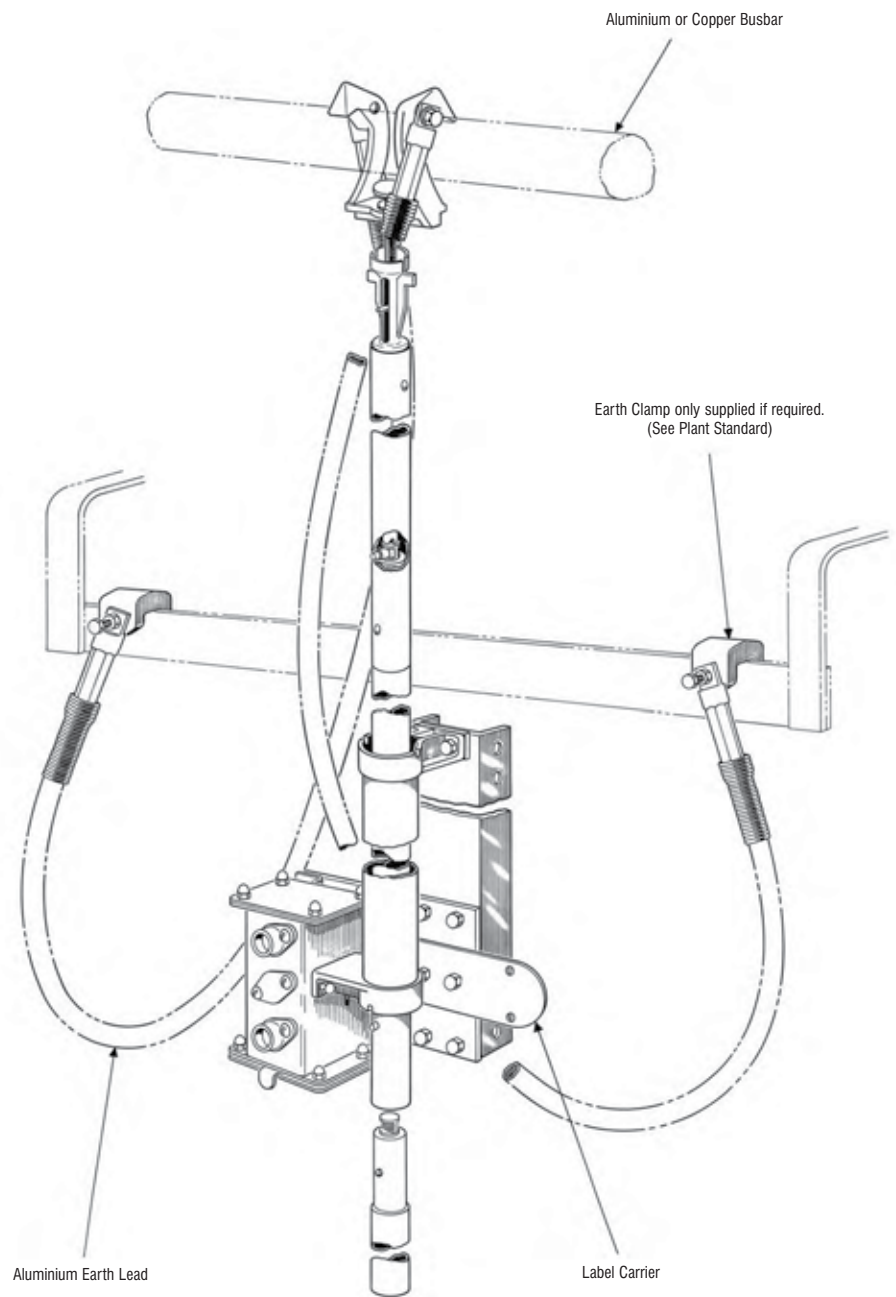

All sizes are in millimetres unless otherwise stated

SECTION 4

General Purpose Earthing Equipment



SECTION 4

General Purpose Earthing Equipment continued

Codes for Clamp Types, Material, Operating Screws and Earth Lead Attachments:-

Material

Code/A Aluminium

Code/B Bronze

Code/MI Malleable Iron

Code/MS Mild Steel

Code/SS Stainless Steel

Operating Screws

Code/SE Square ended Operating Screw/GS1 Socket

Code/LT Long Taper Operating Screw/OL1 Socket

Code/ST Short Taper Operating Screw/CEA Socket or S9D Socket

Code/RT Ring Type Operating Screw/RT Socket

Code/SP Special Operating Screw Assemblies

Code/SH Short Insulated Handle

Code/LH Long Insulated Handle

Code/HW Handwheel

Code/TB Tommy Bar

Code/TS Thumbscrew

Code/HCP Hand-Operated Cross Pin

Earth Lead Attachments

Code/105H 10.5mm hole for bolted Earth Lead Attachment

Code/135H 13.5mm hole for bolted Earth Lead Attachment

Code/JCA Jumper Connector Aluminium

Please refer to our Sales Dept to Discuss your Particular Requirements

Operating Screw SE

CODE SE

Square Ended Operating Screw.

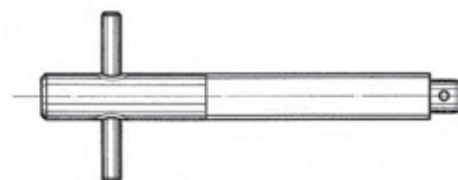

Operating Socket GS1

CODE GS1

Socket for operating Clamps with
Square Ended Operating Screws.

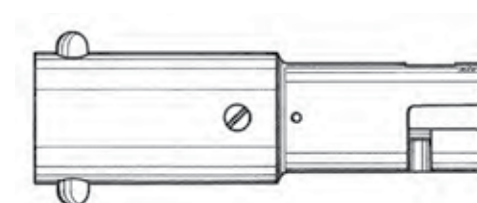

All sizes are in millimetres unless otherwise stated

SECTION 4

General Purpose Earthing Equipment continued



Operating Socket OL1

CODE OL1

Socket for Operating Clamps with Long Taper Operating Screws.

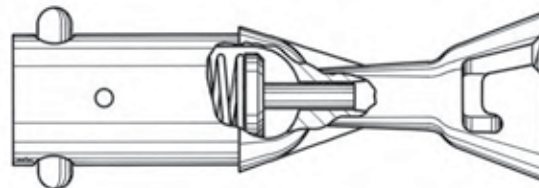

Operating Screw LT

CODE LT

Long taper Operating Screw.

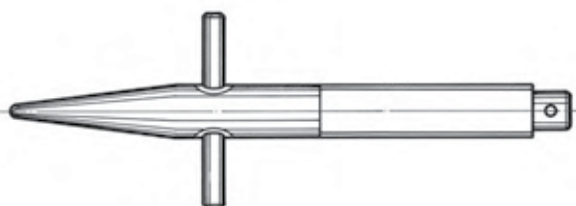

Hook Type Socket

CODE RT Socket

Socket for Operating Clamps with Ring Type Operating Screws. Hook is spring loaded to ensure clamp is securely retained during application.

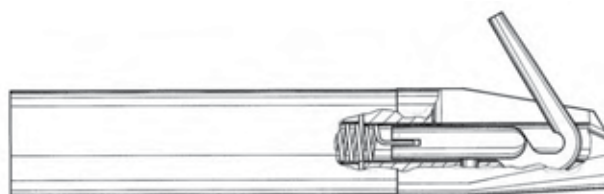

Operating Screw LT

CODE RT

Ring Type Operating Screw.

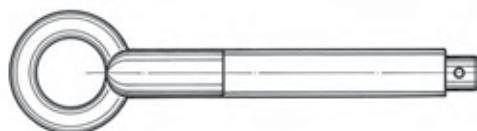

All sizes are in millimetres

SECTION 4

General Purpose Earthing Equipment continued

Short Taper Operating Screw ST

CODE ST

Short Taper Operating Screw.

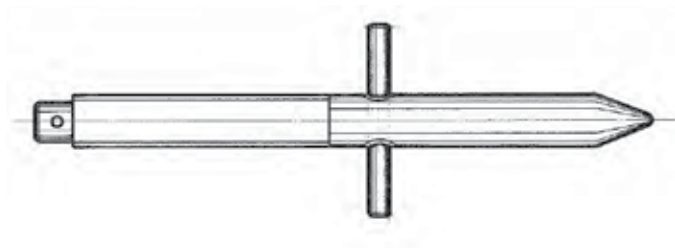

Socket CEA

CODE CEA

Socket for Operating Clamps with Short Taper Operating Screw (Spring Loaded).

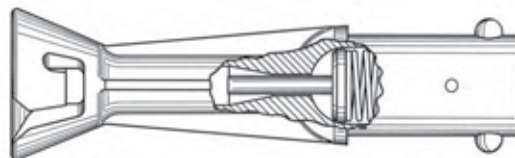

Socket SL

CODE SL

Sliding Socket for Operating Line Clamps with Short Taper Operating Screws.

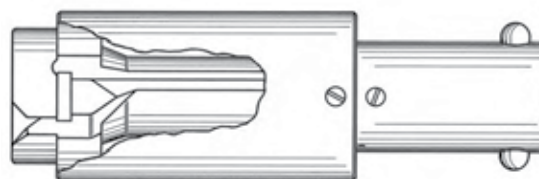

All sizes are in millimetres

SECTION 4

General Purpose Earthing Equipment continued

Tommy Bar type Screw TB **CODE TB**

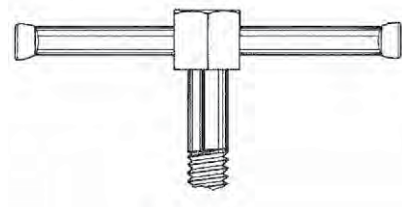

Hand Operating Screw HCP **CODE HCP**

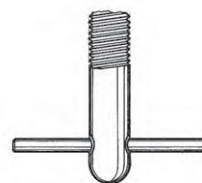

Thumb Screw TS **CODE TS**

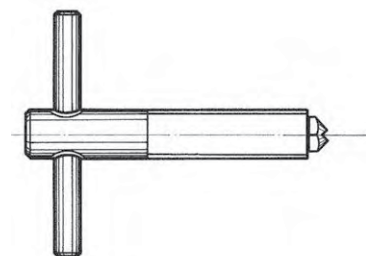

Insulated Handles **CODE SH or LH**

Available in Colours Grey, Red, Orang and Yellow
Available lengths 'X'
SH = 115
LH = 250 or 350

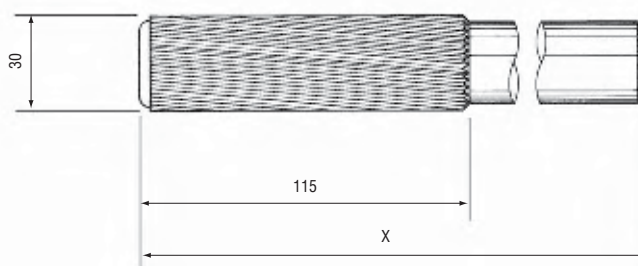

All sizes are in millimetres

SECTION 4

General Purpose Earthing Equipment continued

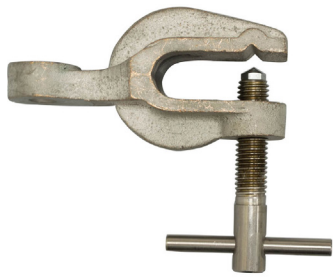

Earth End Clamps CE3
CODE CE3

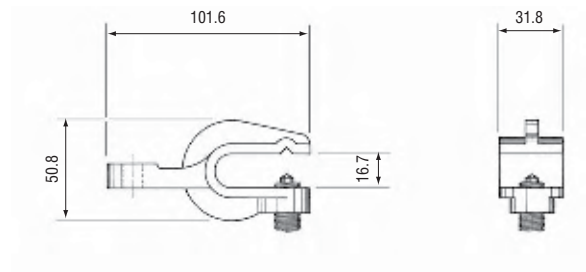

Line End Clamp CE4
CODE CE4
For 22mm to 50mm diameter conductors.

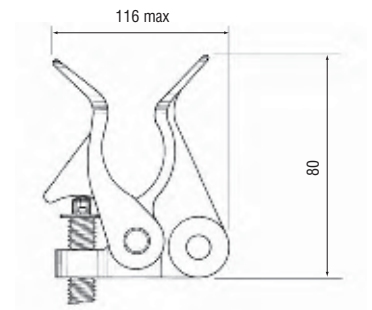

Line End Clamp CE5
CODE CE5
For 12.7mm to 25.4mm diameter conductors.

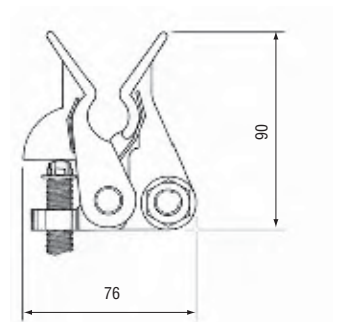

Earth End Clamp with Handwheel CE5/HW
CODE CE5 HW

Special assembly for 12.7mm to 25.4mm diameter conductors
Code CE5/B/HW/135H

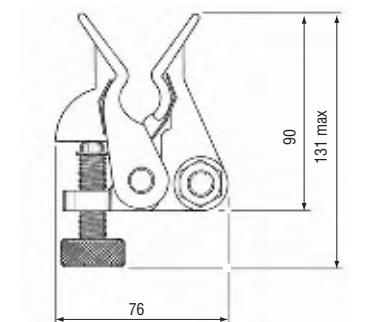

All sizes are in millimetres

SECTION 4

General Purpose Earthing Equipment continued



Line End Clamp CE7

CODE CE7

For 4.2mm to 19.5mm dia conductors.

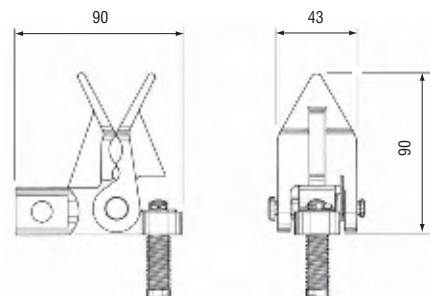

Earth End Clamp CE10

CODE CE10

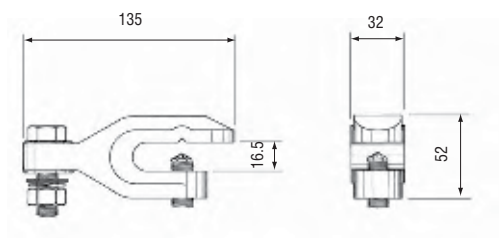

Line End Clamp C12

CODE CE12

For 20mm thick bars and up to 15mm diameter round conductors.
Tested to 17.5kA for 2 seconds.

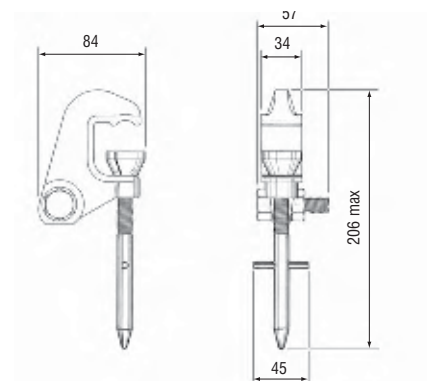

All sizes are in millimetres

SECTION 4

General Purpose Earthing Equipment continued



Line End Clamp CE15

CODE CE15

For 90mm diameter conductors.
Provision for attachment of two flexible leads.

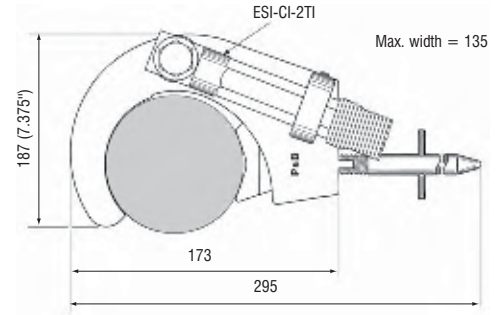

Line End Clamp CE27

CODE CE27

For 101.6mm diameter conductors.
Tested to 17.5kA for 2 seconds.

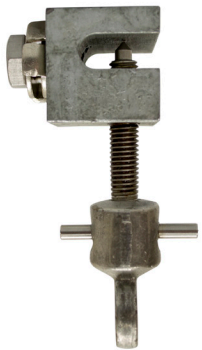
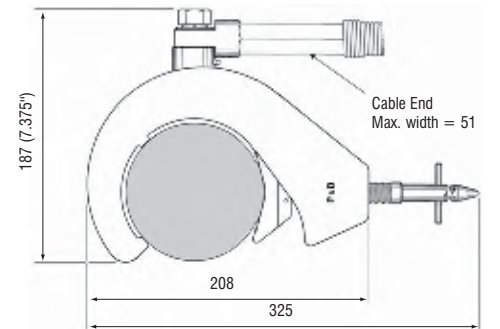

Earth End Clamp For Pole Operation CE29

CODE CE29

Suitable for cross arm straps.

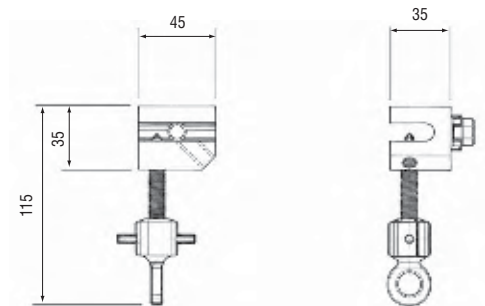

Line End Clamp CE33

CODE CE33

For 4.7mm to 15mm conductors.
L. V. Line shorting and by-pass jumper connector.

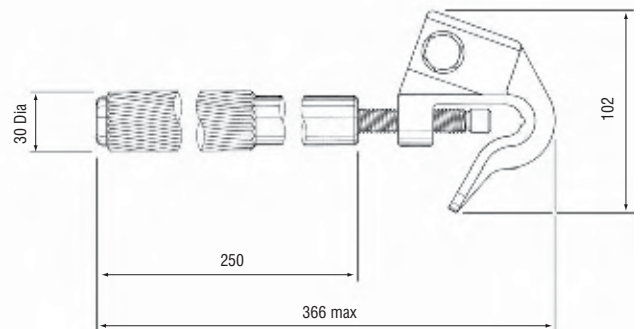

All sizes are in millimetres

SECTION 4

General Purpose Earthing Equipment continued

Earth End Clamp CE35

CODE CE35

Suitable For:-
‘T’ Bar Earthing Stubs
Ball Type Earthing Stubs
Flat Bar:-
Max Thickness 12mm
Min Width 31mm
Round Bar:-
Max 25mm Diameter
Min 12mm Diameter
Tested at 17.5kA
(indoor use only)

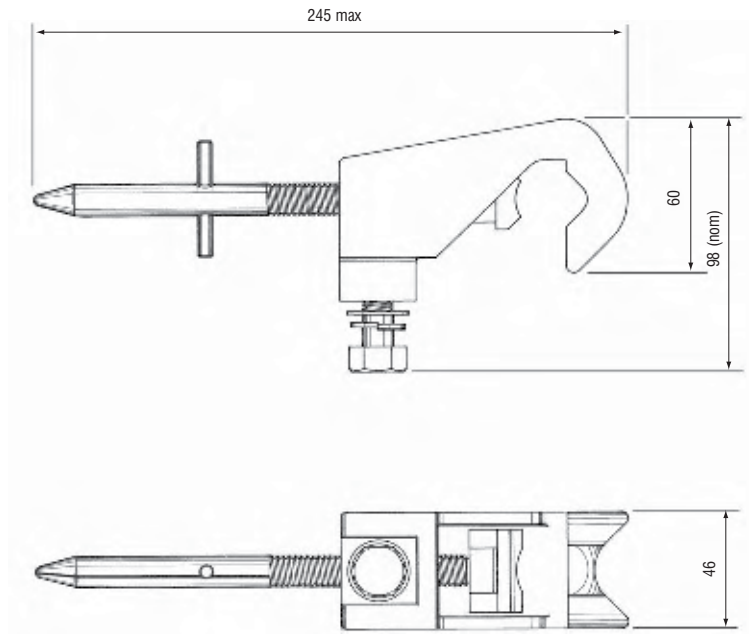

Line End Clamp H1B

CODE H1B

H1B Live Line Tap
Conductor range 5.7 to 11.0mm Diameter

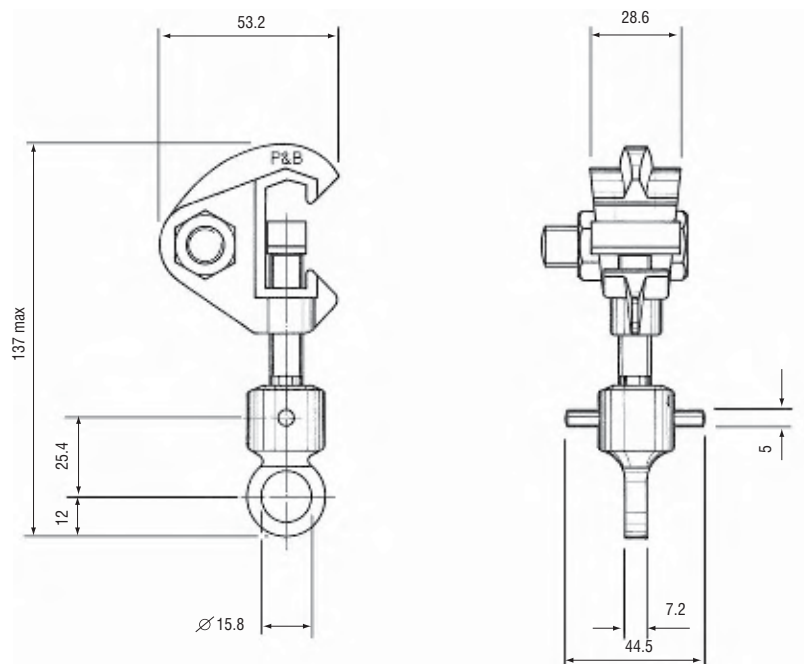

All sizes are in millimetres

SECTION 4

General Purpose Earthing Equipment continued



Earth End Clamp S9A

CODE S9A/A/TB/PT/135H

Fitted with Hardened Steel Tip.
For up to 20mm thick bars.
Tested to 17.5kA for 2 seconds.

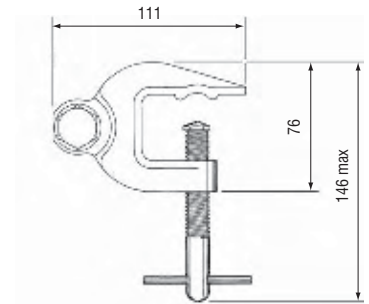

Earth End Clamp S9A

CODE S9A/A/-/RB/135H

Fitted with Aluminium Alloy Rocker Block
For 12.7mm thick bars and for 6.4 to 20mm round conductors
Tested to 17.5kA for 2 seconds.

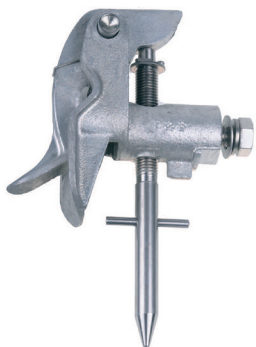
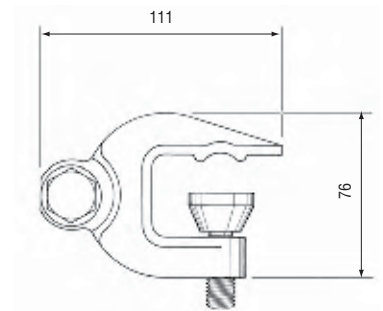

Line End Clamp S9B

CODE S9B

For 6.3mm to 38mm diameter conductors.
Tested to 17.5kA for 2 seconds

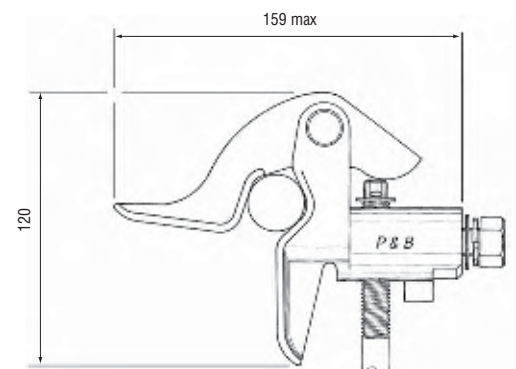

Line End Clamp S9C

CODE S9C

For 38mm to 76mm diameter conductors.
Tested to 17.5kA for 2 seconds

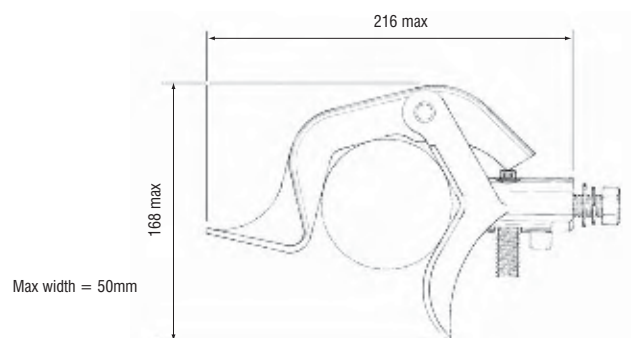

All sizes are in millimetres

SECTION 5

Portable Earthing Equipment for Electro-static Precipitators



This equipment is specifically portable earthing for maintenance on electrostatic flue-gas precipitators in generating stations and local authorities waste disposal units.

It has been designed to provide safe and sure clamping to the special stubs (Fig. 1) which are fillet-welded into the appropriate positions on to the precipitator electrode frame in accordance with BS135.

SECTION 5

Portable Earthing Equipment for Electro-static Precipitators *continued*

1. Scope

The equipment illustrated in Figs 1 to 6 provides portable earthing for maintenance in accordance with the CEGB Safety Rules and National Safety Code of Practice SR-EM 21.

2. Design and Construction

Both Line end clamp and earth end clamp are designed with an ultimate strength well in excess of normal working loads and all designs are type tested at normal loading before being approved.

3. Equipment

3.1-Line End Clamp

This is designed to make positive line contact with the spherical stub no matter what the angle of application and it should be applied by means of the operating socket Fig 6 attached to the appropriate insulated operating pole.

3.2-Earth End Clamp

This should be applied by hand to the appropriate earth bar to the maximum torque possible without the use of mechanical aids.

3.3-Operating Socket

Made in light alloy and illustrated in Fig 6 and is fitted with an enclosed spring to give a positive hold to the conductor clamp when it is being applied.

3.4-Operating Poles – Insulated

These are limited in length to a maximum of 2440mm. There are two types.

1. A 1220mm long top section fitted with the appropriate socket, plus a 1220mm bottom section Figs 7a & b.

2. A 2440mm long telescopic pole also fitted with the

appropriate socket but capable of closing down to 1220 mm for ease of transportation. Fig 7c.

3.5-Earth Leads

Only cables by approved manufactures and fitted with approved compression lugs shall be supplied for the earthing lead connection between the conductor clamps and earth end clamps. The flexible conductor shall be stranded 312/0.45mm aluminium (50mm² aluminium) with clear / green translucent PVC sheathing to an overall diameter of approximately 12.4mm.

4. Certification of clamps and cables.

All completed equipment i.e. conductor clamp, earth clamp and interconnection lead are to be subjected to a resistance test as appropriate.

All measurements in millimetres

Stub ST/M.S/225/1

Fig. 1

Code ST/M.S/225/1
Stub - Weld on type

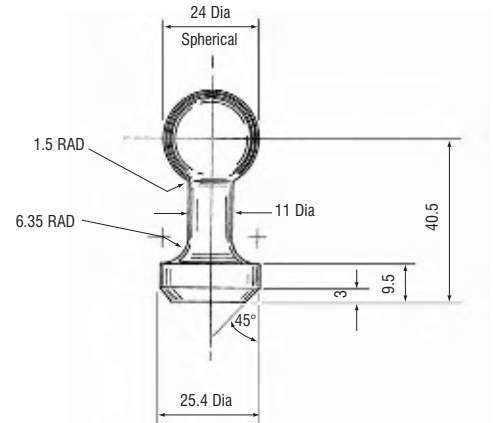

All sizes are in millimetres unless otherwise stated

SECTION 5

Portable Earthing Equipment for Electro-static Precipitators continued

Line End Clamp CE30

Fig. 3

Code CE30/SS/225/2

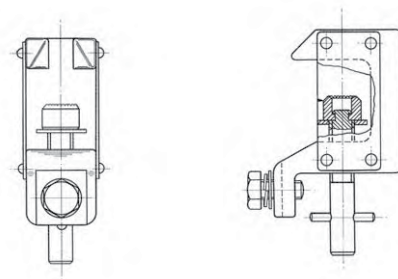

Ball Stub Bolt on

Fig. 4

Bolted type Ball type Stub.

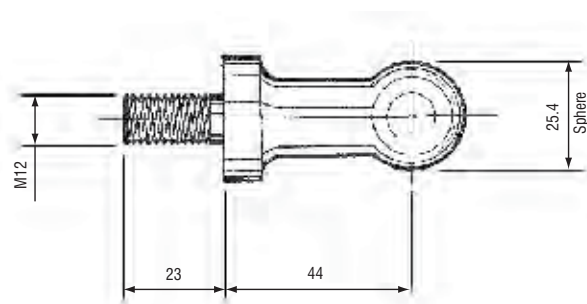

T/Bar Stub

Fig. 5

Bolted type T/Bar Stub.

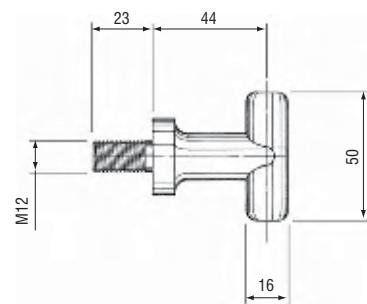

Operating Socket GS1

Fig. 6

Code GS1/A/225/4

Operating Socket.

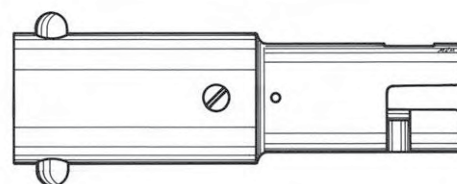

All sizes are in millimetres

Pole Sections

Fig. 7. (a) CODE GFP4/TS

- Top Section Pole
- (b) CODE GFP4/BS
- Bottom Section
- Extension Pole
- (c) CODE GFP4/BTEL
- Telescopic Pole

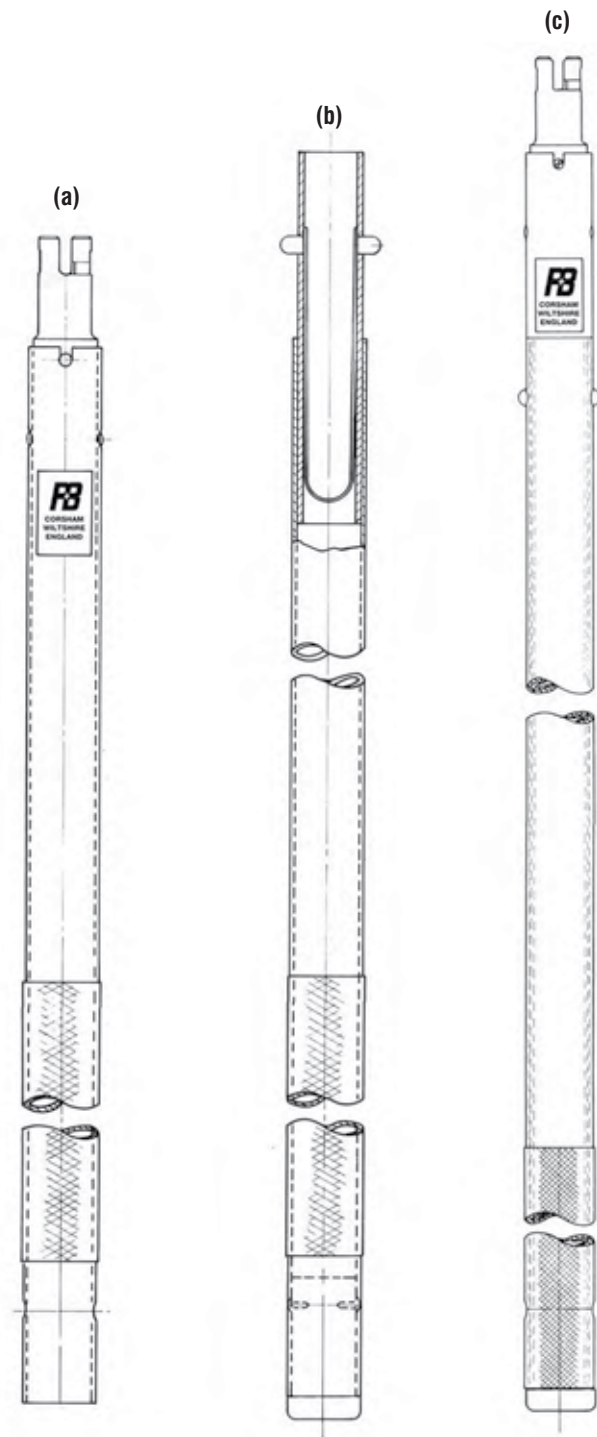

SECTION 6

Earthing Stubs

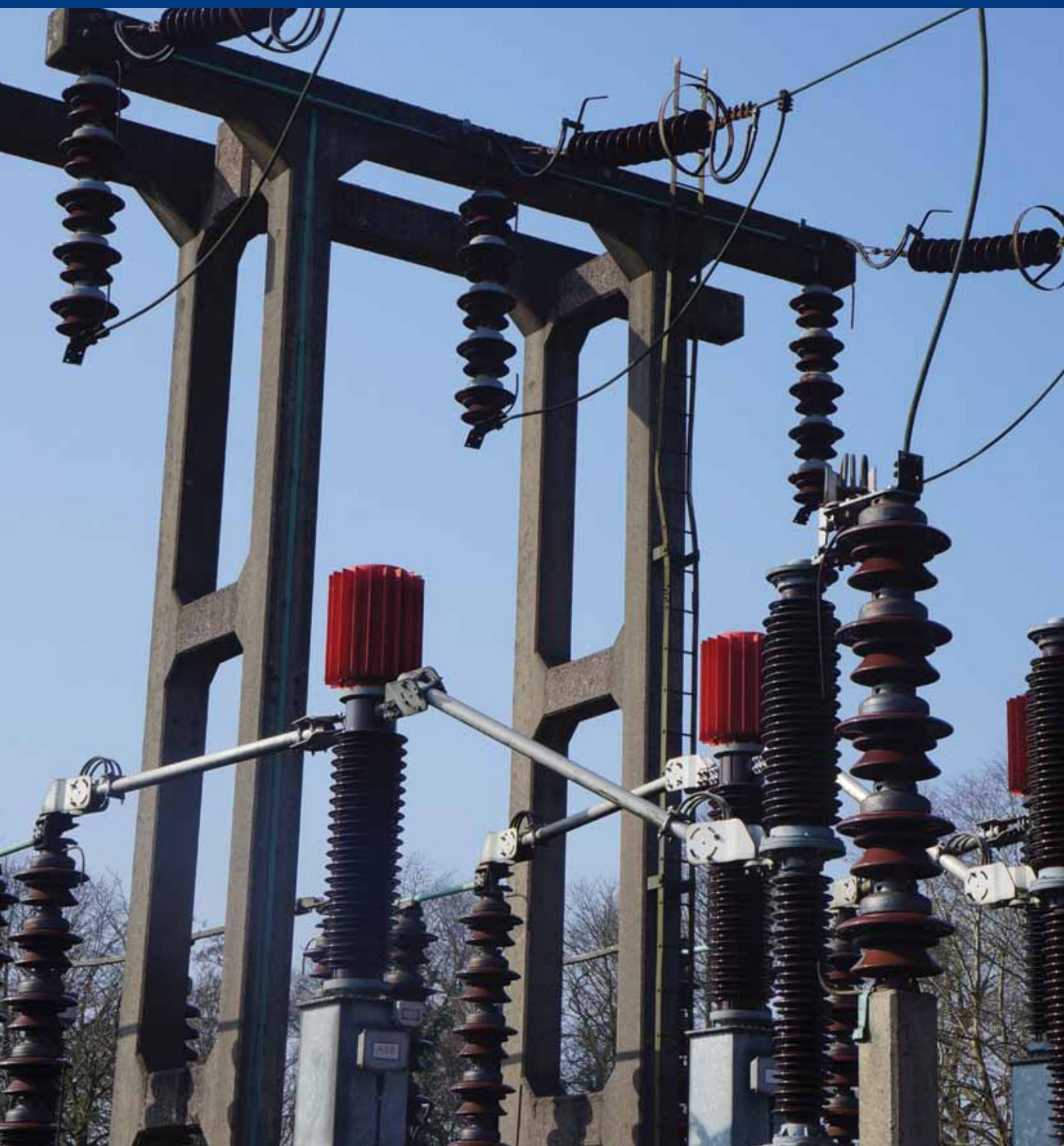

SECTION 6

Earthing Stubs continued

1. Scope

The stubs illustrated in figures 1-11 inclusive may be mounted in stipulated positions in the appropriate aluminium or copper substations.

2. Design

The stubs are designed with bolt fixing centres of 127mm P.C.D. or 178mm P.C.D. according to their appropriate mounting positions. Check if the type required has the correct fixing centres for the position in which it is to be mounted.

3. Mounting

1. The stubs must be mounted in stipulated positions in the appropriate aluminium or copper busbar substations.

2. On 275 kV or 400 kV substations, where the stubs are not located below and parallel with the busbar, corona shields may be fitted as an integral part of the stub. See Figure 11. This applies to aluminium stubs only.

Notes:

- a) Stub lengths other than those illustrated on request.
- b) Apply NGC standard jointing procedure when fitting to switchgear equipment.

Type A Aluminium

CODE A/127/X290/AL

Suitable for 275kV (15000MVA) RCP isolators and 132kV (5000MVA) posts and isolators.

CODE A/127/X230/AL

Suitable for portable earths.

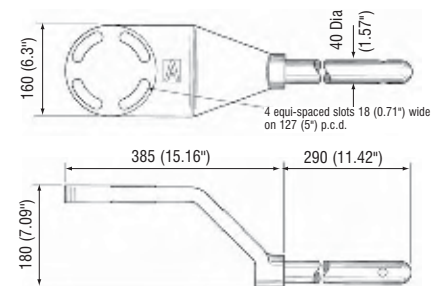

Type A Bronze

CODE A/127/X495/BZ

Suitable for 275kV (15000MVA) REP isolators.

CODE A/127/X290/BZ

Suitable for 132kV (5000MVA) posts and isolators.

CODE A/127/X230/BZ

Suitable for portable earths.

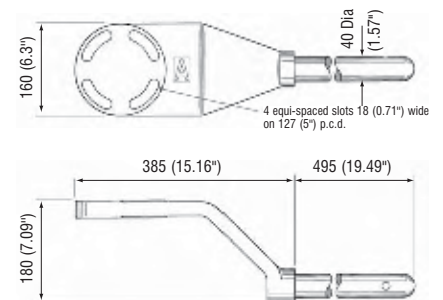

Type B Bronze

CODE B/178/X40/BZ

Suitable for 275kV (15000MVA) posts.

CODE B/178/X460/BZ

CODE B/178/X290/BZ

General purposes.

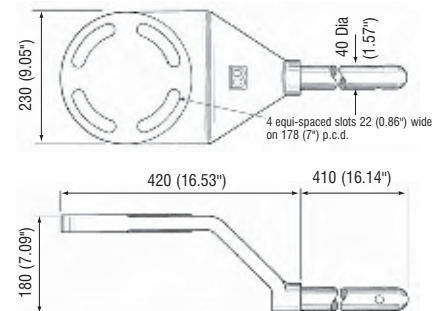

All sizes are in millimetres

SECTION 6

Earthing Stubs continued

Type B Aluminium

Fig. 4

CODE B/178/X290/AL

Suitable for 275kV (15000MVA) posts.

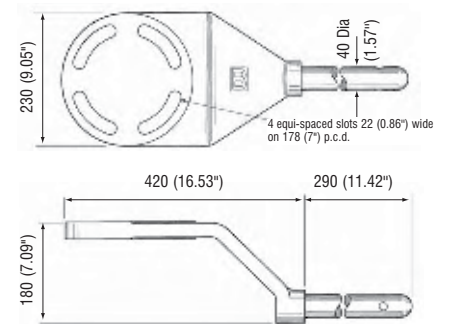

Type C Aluminium

Fig. 5

CODE C/90/X230/AL

CODE C/90/X165/AL

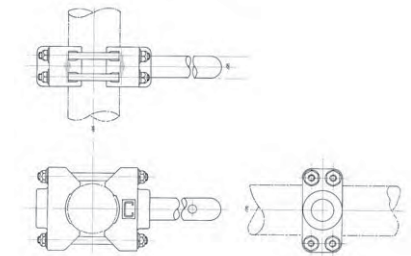

Type D Aluminium

Fig. 6

CODE D/63.5/X230/AL

For isolator or circuit breaker head.

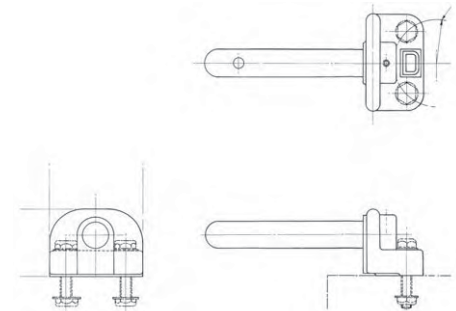

Type E&M Bronze

Fig. 7

CODE E/75/X410/BZ

CODE M/38/X203/BZ

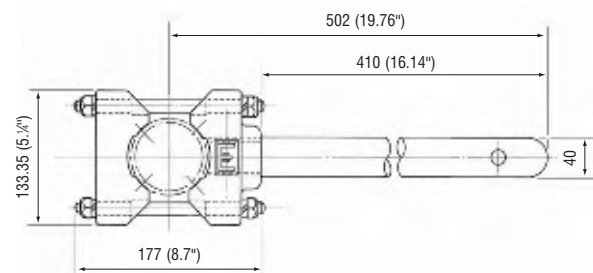

All sizes are in millimetres

Type H Aluminium

Fig. 8.

CODE H/140/X381/AL

CODE H/165/X381/AL

Suspended types for 140 diam. and 165 diam. busbars.

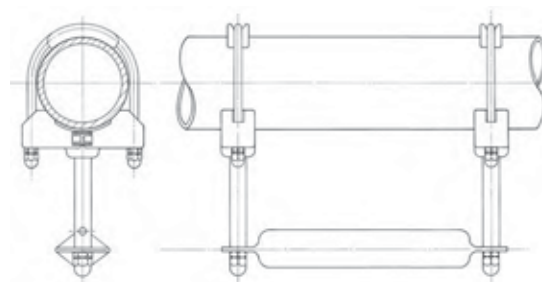

Type K Aluminium

Fig. 9.

CODE K/63.5/X254/AL

For portable Earths

Mounting: Isolator or circuit breaker head.

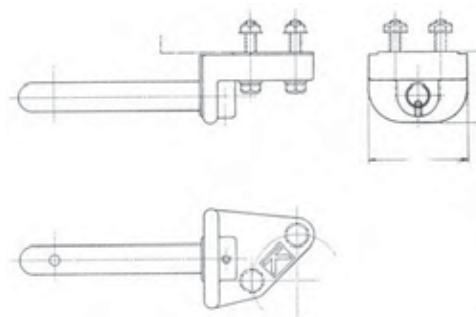

Type L Aluminium

Fig. 10.

CODE L/69.85/X445/AL

CODE L/69.85/X470/AL

Suitable for fixed earthing devices

Mounting: Isolator head.

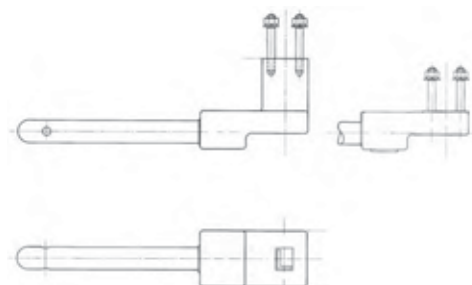

Corona Shields

Fig. 11.

CODE CS/Al

Available as integral or Bolt-on Type for 275kV.

Available as Bolt-on Type for 400kV.

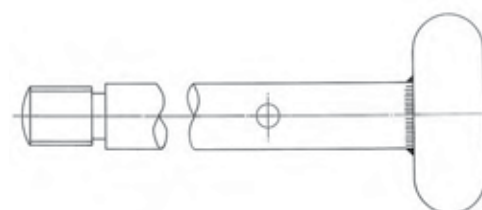



serving the procurement professional



Supplier Number: 26848

UVDB standard

PREQUALIFY YOUR BUSINESS TO THE UTILITIES SECTOR

Electrical Metals & Components

Alcomet



t: +44 (0) 1384 404488

f: +44 (0) 1384 404477

e: sales@alcomet.net

www.alcomet.net



We are constantly reviewing and updating our products,
for the latest information please call us on: +44 (0) 1384 404488
or visit our website at: www.alcomet.net

Alcomet Limited, Unit 5, Gibbons Industrial Park, Dudley Road
Kingswinford, West Midlands, DY6 8XF UK

©2014 Alcomet Limited.