



Technical Data

PT225

Vehicle mounted platform

Tel: 01274 666 676 Fax: 01274 669 000 Email:sales@trackedaccessplatforms.com Web:www.trackedaccessplatforms.com

Max. working height:	22.50m
Max. outreach:	13.50m
Cage capacity:	230kg
No. of operators:	2
Max. manual force:	40 daN
Max. wind speed:	12 m/s
Boom configuration:	4 section telescopic
Boom Angle:	-24°/+80°
Turret rotation:	400°
Platform size:	1400mmx710mmx1100mm
Platform rotation:	90° left 90° right
Hydraulic outrigger type:	Extending Horizontal 'H' type front and rear
Outriggers minimum width:	Front 2.03m/3.33m Rear 2.03m/3.07m
Controls:	Electro hydraulic
Minimum vehicle installation:	3.5T

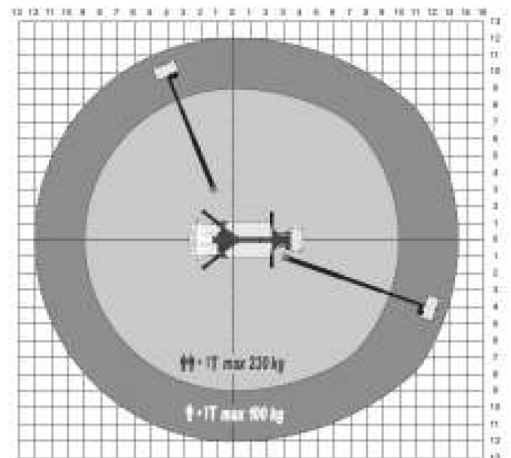
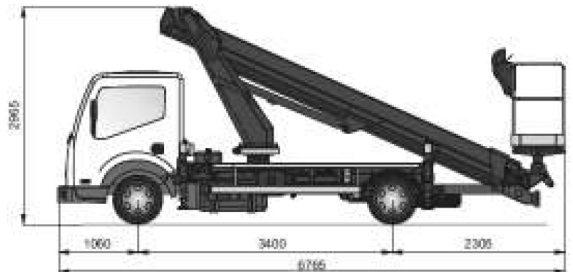
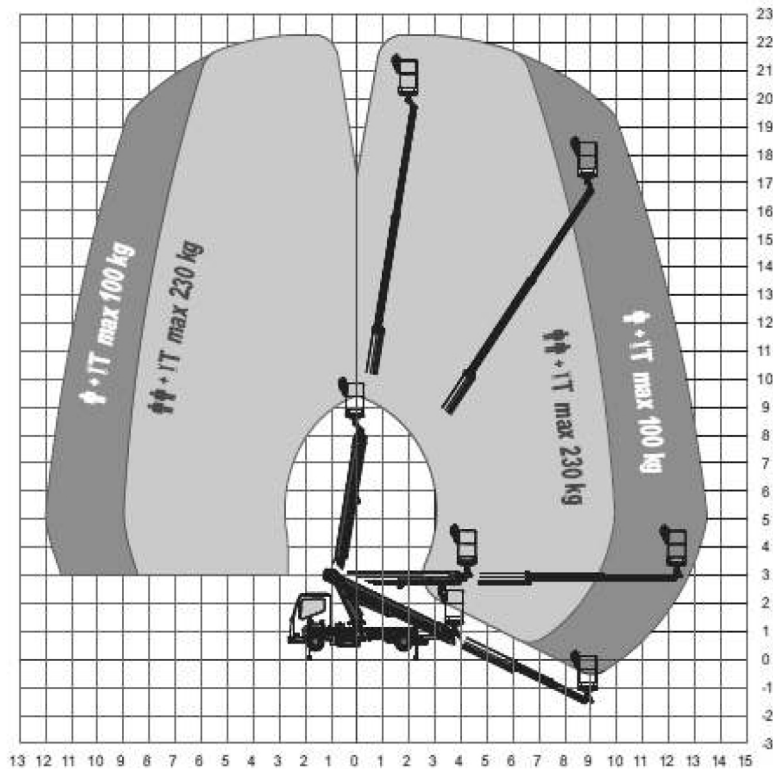

STANDARD DEVICES

Proportional hydraulic controls mounted in the cage with the ability to carry out several operations simultaneously, ground controls also provided for emergency manoeuvres *Outrigger controls on the truck body *Overload device in the cage *Check valves on all hydraulics *Interlocking safety device between outriggers & boom *Emergency over ride hand pump *Cage can be positioned on the ground *Cage floor in non slip aluminium *Tool box on truck body *One magnetic orange safety beacon *Engine can be stopped from the cage and ground controls *Power outlet in the cage *Hour meter *Cage access ladder *Mud guards with splash flaps on rear wheels *Radius restrictor *Anti-collision device between boom & cab and front outriggers & door *Fully CE approved *Custom painting