



## Maximum Security Operators

9200 and 9500 series operators are designed to operate vehicular sliding gates used in Limited (Class III) and Restricted (Class IV) industrial and maximum security applications only. These operators must never be used in Residential (Class I) or Commercial (Class II) applications, or in any application where the gate is operated by the General Public.

These operators must be installed with external entrapment prevention devices, Type B1 (non-contact) or Type B2 (contact), or a combination of both to insure all entrapment hazard areas are protected. **9500 Series operators require a minimum of one (1) Type B1 AND one (1) Type B2 in EACH direction of travel.** Refer to the Installation Manual for important safety information.

## Minimum Gate Length

Most 9200 and 9500 Series operators have variable speed capability which allows the user to adjust the speed of the gate. On most operators, the speed can be set for speeds up to 2 Ft/sec., and on certain models the gate speed can be set up to 4 Ft/sec. When using these higher speeds, there is a time factor to consider during the start-up and the slow-down of the gate. For this reason, you will see a minimum gate length on operators design to move a gate at the higher speeds.

## UL 325 – August 2018 Update

Requirements mandated by the safety standard (UL 325) that DKS gate operators are listed to require that photo-beams and contact edges used for entrapment protection must be monitored. Entrapment protection must be provided for the gate system where the risk of entrapment exist. The gate operator will not run without one or more external entrapment protection devices installed in each direction of travel. Check the gate operator installation manual for a list of external entrapment protection devices that can be used with DKS gate operator products.

The August, 2018 update to the safety standard requires that a minimum of two independent means of entrapment protection must be provided, in each direction of travel, where the risk of entrapment exists. The actual number of external devices required is dependent on the gate system layout and the number of entrapment areas that will need to be protected. Installers will have to identify all potential areas where the risk of entrapment exist and how best to protect those areas. For example, some gates may require two (or more) external devices in each direction of travel to protect all potential areas of entrapment. **9500 Series operators require a minimum of one (1) Type B1 AND one (1) Type B2 in EACH direction of travel.**

There is an exception for swing gates and vertical lift gates regarding the minimum of two entrapment protection devices in each direction of travel. For example, if on a swing gate system there is no potential for entrapment in the opening direction, then only the close direction will require a minimum of two means of entrapment protection. Installers will have to determine if any entrapment hazards exist in the opening direction, and if so, then those areas will have to be protected with external devices.

Vertical lift gates require two means of entrapment protection in the down cycle, but will only require one means of entrapment protection in the up cycle. The model 1175 is considered to be a vertical lift gate operator for entrapment protection means requirements.

Barrier gate operators that are installed in such a way that the barrier arm does not come closer than 16 inches to a rigid object are not required to protect against entrapment.

The table below shows the minimum entrapment protection requirements for each type of gate operator in the scope of the UL 325 Standard for Safety.

	Opening	Closing
Horizontal Slide Gate	2	2
Horizontal Swing Gate	2*	2*
Vertical Pivot Gate	2	2
Vertical Lift gate	1	2

\* For a horizontal swing gate operator, at least two independent entrapment protection means are required in each direction of travel. Except, if there is no entrapment zone in one direction of travel, only one means of entrapment protection is required in that direction of travel; however, the other direction must have two independent entrapment protection means.

## Blank Page

## Table of Contents

### Maximum Security Slide Gate Operators

Model 9210 .....	6
Model 9220 .....	8
Model 9230 .....	10
Model 9235 .....	12
Model 9240 .....	14

### Heavy-Duty Maximum Security Slide Gate Operators

9500 Series .....	16
-------------------	----

## 9210 Slide Gate Operator

### Maximum Security Slide Gate Operator

#### 9210

- Adjustable Limits
- Plug-in Loop Detector Ports
- Built-in power and reset switches
- Two 115 VAC convenience outlets
- Partial open / anti-tailgate feature
- 40:1 Gear Reducer Drive Train
- Fixed Speed
- 20-Feet (6m) #50 / #60 Chain
- Gate tracker data output
- Selectable stop/ reverse function

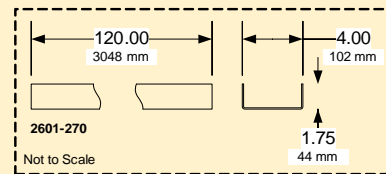
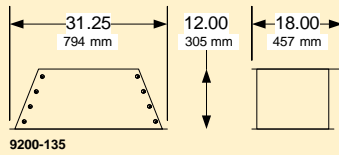
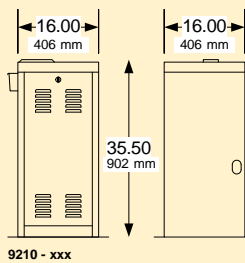

Model	Chain	Speed Fixed	Maximum Gate Weight	Maximum Gate Length	Minimum Gate Length	Mount	Class of Operation <sup>1</sup>	Voltage VAC	HP	Power Outlets	Loop Ports <sup>2</sup>
9210	#50	1 Ft/sec .3m/sec	2000 Lbs <sup>3</sup> 907 Kg	100 Ft 30m	10 Ft 3m	Pad or Pedestal <sup>3</sup>	III, IV	115 208, 230	1	2	2
	#60		3000 Lbs <sup>3</sup> 1360 Kg								

1. III = Limited Access; IV = Restricted Access
2. Plug-in loop detector ports; open and reverse. DoorKing plug-in loop detectors only.
3. Requires 9200-135 pedestal.

## 9210 Slide Gate Operator

## Maximum Security Slide Gate Operator

### Operators w/#50 Chain

9210-380 1 HP, 115V (9.7A) .....	5134.50
9210-382 1 HP, 208V 1° (5.0A) .....	5190.00
9210-384 1 HP, 230V 1° (4.9A) .....	5190.00
9210-386 1 HP, 208V 3° (3.4A) .....	5418.00
9210-388 1 HP, 230V 3° (3.3A) .....	5418.00

### Operators w/#60 Chain

9210-381 1 HP, 115V (9.7A) .....	5214.00
9210-383 1 HP, 208V 1° (5.0A) .....	5277.00
9210-385 1 HP, 230V 1° (4.9A) .....	5277.00
9210-387 1 HP, 208V 3° (3.4A) .....	5505.00
9210-389 1 HP, 230V 3° (3.3A) .....	5505.00

### Choose Entrapment Protection (required) Devices

*Use Type B1 (non-contact) and/or Type B2 (contact) entrapment protection devices to protect all areas where the risk of entrapment exist - see Section A1, pages 42-43.*

**Operator will not run without entrapment protection device(s) connected to the controller board.**

### Loops and Loop Detectors

*See section A1, page 44 for a complete list of all loop detectors, prefabricated loops and loop accessories available.*

### Accessories

9200-135 Mounting Pedestal .....	939.00
2601-270 Chain Tray Kit 10 Ft (3m) <sup>1</sup> .....	418.50
1601-195 Heater Kit 120 VAC <sup>2</sup> .....	796.50
1601-197 Heater Kit 208/230 VAC <sup>2</sup> .....	Note 3

*1. 9200-135 required if chain tray is used.*

*2. Use if temperature routinely falls below 10°F (-12°C).*

### Chain

2600-485 #50 Chain, 20-Ft (6 m) .....	171.00
2600-448 #60 Chain, 20-Ft (6 m) .....	274.50

## 9220 Slide Gate Operator

### Maximum Security Slide Gate Operator

#### 9220

- Adjustable Limits
- Plug-in Loop Detector Ports
- Built-in power and reset switches
- Two 115 VAC convenience outlets
- Partial open / anti-tailgate feature
- 40:1 Gear Reducer Drive Train
- Variable Speed
- 20-Feet (6m) #60 Chain
- Gate tracker data output
- Selectable stop/ reverse function

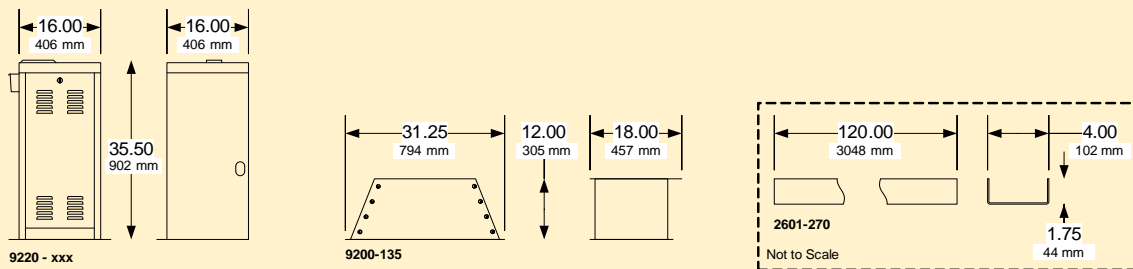

Model	Chain	Speed Variable	Maximum Gate Weight	Maximum Gate Length	Minimum Gate Length	Mount	Class of Operation <sup>1</sup>	Voltage VAC	HP	Power Outlets	Loop Ports <sup>2</sup>
9220	#60	1-2 Ft/sec .3-.6m/sec	2000 Lbs <sup>3</sup> 907 Kg	100 Ft 30m	20 Ft 6m	Pad or Pedestal <sup>3</sup>	III, IV	208, 230	2	2	2

1. III = Limited Access; IV = Restricted Access
2. Plug-in loop detector ports; open and reverse. DoorKing plug-in loop detectors only.
3. Requires 9200-135 pedestal.



## 9220 Slide Gate Operator

## Maximum Security Slide Gate Operator

### Operators w/#60 Chain

9220-381 2 HP, 208V 1° (11.7A).....	6355.50
9220-383 2 HP, 230V 1° (11.5A).....	6355.50
9220-385 2 HP, 208V 3° (6.6A).....	6583.50
9220-387 2 HP, 230V 3° (6.2A).....	6583.50

### Choose Entrapment Protection (required) Devices

Use Type B1 (non-contact) and/or Type B2 (contact) entrapment protection devices to protect all areas where the risk of entrapment exist - see Section A1, pages 42-43.

**Operator will not run without entrapment protection device(s) connected to the controller board.**

### Loops and Loop Detectors

See section A1, page 44 for a complete list of all loop detectors, prefabricated loops and loop accessories available.

### Accessories

9200-135 Mounting Pedestal.....	939.00
2601-270 Chain Tray Kit 10 Ft (3m) <sup>1</sup> .....	418.50
1601-197 Heater Kit 208/230 VAC <sup>2</sup> .....	Note 3
1. 9200-135 required if chain tray is used.	
2. Use if temperature routinely falls below 10°F (-12°C).	

### Chain

2600-448 #60 Chain, 20-Ft (6 m).....	274.50
--------------------------------------	--------

## 9230 Slide Gate Operator

### Maximum Security Slide Gate Operator

#### 9230

- Adjustable Limits
- Plug-in Loop Detector Ports
- Built-in power and reset switches
- Two 115 VAC convenience outlets
- Partial open / anti-tailgate feature
- 40:1 Gear Reducer Drive Train
- Variable Speed
- 20-Feet (6m) #60 Chain
- Gate tracker data output
- Selectable stop/ reverse function

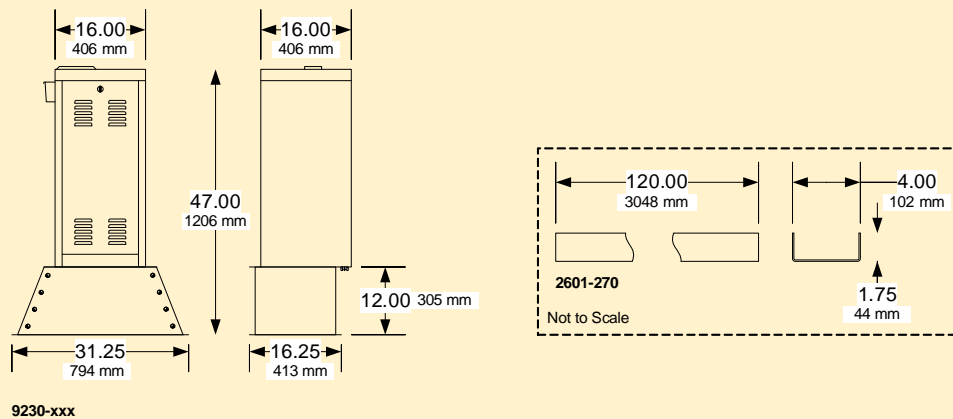

Model	Chain	Speed Variable	Maximum Gate Weight	Maximum Gate Length	Minimum Gate Length	Mount	Class of Operation <sup>1</sup>	Voltage VAC	HP	Power Outlets	Loop Ports <sup>2</sup>
9230	#60	1-2 Ft/sec .3-.6m/sec	5000 Lbs <sup>3</sup> 2267 Kg	100 Ft 30m	20 Ft 6m	Pedestal <sup>3</sup>	III, IV	208, 230	3	2	2

1. III = Limited Access; IV = Restricted Access
2. Plug-in loop detector ports; open and reverse. DoorKing plug-in loop detectors only.
3. 9200-135 pedestal included.

## 9230 Slide Gate Operator

## Maximum Security Slide Gate Operator

### Operators w/#60 Chain

---

9230-380 3 HP, 208V 3° (9.8A).....	9166.50
9230-381 3 HP, 230V 3° (9.6A).....	9166.50

### Choose Entrapment Protection (required) Devices

---

*Use Type B1 (non-contact) and/or Type B2 (contact) entrapment protection devices to protect all areas where the risk of entrapment exist - see Section A1, pages 42-43.*

**Operator will not run without entrapment protection device(s) connected to the controller board.**

### Loops and Loop Detectors

---

*See section A1, page 44 for a complete list of all loop detectors, prefabricated loops and loop accessories available.*

### Accessories

---

2601-270 Chain Tray Kit 10 Ft (3m).....	418.50
1601-197 Heater Kit 208/230 VAC <sup>1</sup> .....	Note 2
<i>1. Use if temperature routinely falls below 10°F (-12°C).</i>	
<i>2. See Section A1, page 31 for pricing.</i>	

### Chain

---

2600-448 #60 Chain, 20-Ft (6 m).....	274.50
--------------------------------------	--------

## 9235 Slide Gate Operator

## Maximum Security Slide Gate Operator

### 9235

- Adjustable Limits
- Plug-in Loop Detector Ports
- Built-in power and reset switches
- Two 115 VAC convenience outlets
- Partial open / anti-tailgate feature
- 10:1 Gear Reducer Drive Train
- Variable Speed
- 20-Feet (6m) #60 Chain
- Gate tracker data output
- Selectable stop/ reverse function

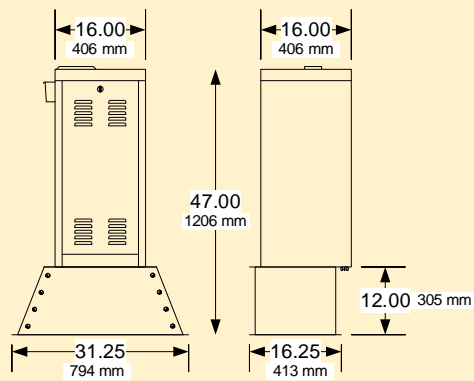

9235-xxx

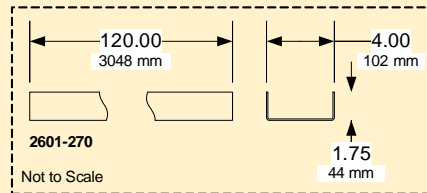

Model	Chain	Speed Variable	Maximum Gate Weight	Maximum Gate Length	Minimum Gate Length	Mount	Class of Operation <sup>1</sup>	Voltage VAC	HP	Power Outlets	Loop Ports <sup>2</sup>
9235	#60	1-4 Ft/sec .3-1.2m/sec	3000 Lbs <sup>3</sup> 1360 Kg	100 Ft 30m	30 Ft 9m	Pedestal <sup>3</sup>	III, IV	208, 230	3	2	2

1. III = Limited Access; IV = Restricted Access
2. Plug-in loop detector ports; open and reverse. DoorKing plug-in loop detectors only.
3. 9200-135 pedestal included.

## 9235 Slide Gate Operator

## Maximum Security Slide Gate Operator

### Operators w/#60 Chain

---

9235-380 3 HP, 208V 3° (12.8A).....	13,656.00
9235-381 3 HP, 230V 3° (12.6A).....	13,656.00

### Choose Entrapment Protection (required) Devices

---

*Use Type B1 (non-contact) and/or Type B2 (contact) entrapment protection devices to protect all areas where the risk of entrapment exist - see Section A1, pages 42-43.*

**Operator will not run without entrapment protection device(s) connected to the controller board.**

### Loops and Loop Detectors

---

*See section A1, page 44 for a complete list of all loop detectors, prefabricated loops and loop accessories available.*

### Accessories

---

2601-270 Chain Tray Kit 10 Ft (3m).....	418.50
1601-197 Heater Kit 208/230 VAC <sup>1</sup> .....	Note 2
<i>1. Use if temperature routinely falls below 10°F (-12°C).</i>	
<i>2. See Section A1, page 31 for pricing.</i>	

### Chain

---

2600-448 #60 Chain, 20-Ft (6 m).....	274.50
--------------------------------------	--------

## 9240 Slide Gate Operator

### Maximum Security Slide Gate Operator

#### 9240

- Adjustable Limits
- Plug-in Loop Detector Ports
- Built-in power and reset switches
- Two 115 VAC convenience outlets
- Partial open / anti-tailgate feature
- 40:1 Gear Reducer Drive Train
- Variable Speed
- 20-Feet (6m) #80 Chain
- Gate tracker data output
- Selectable stop/ reverse function

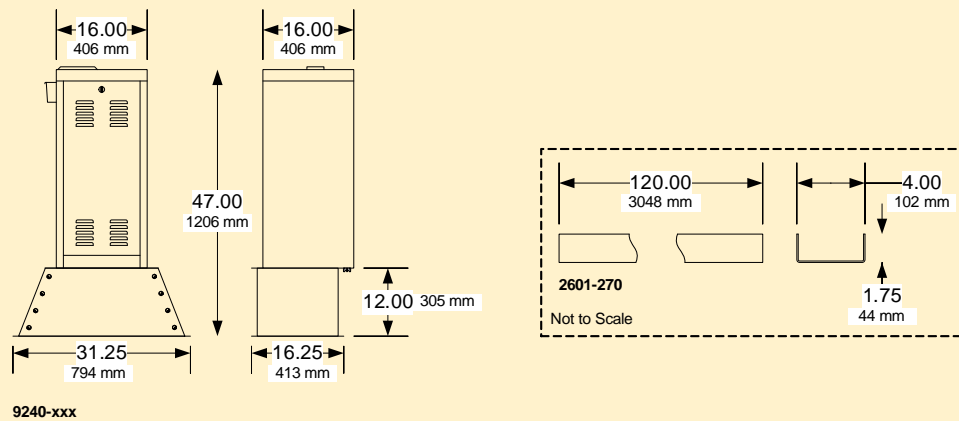

Model	Chain	Speed Variable	Maximum Gate Weight	Maximum Gate Length	Minimum Gate Length	Mount	Class of Operation <sup>1</sup>	Voltage VAC	HP	Power Outlets	Loop Ports <sup>2</sup>
9240	#80	1-2 Ft/sec .3-.6m/sec	8000 Lbs <sup>3</sup> 3628 Kg	100 Ft 30m	25 Ft 7.6m	Pedestal <sup>3</sup>	III, IV	208, 230	3	2	2

1. III = Limited Access; IV = Restricted Access
2. Plug-in loop detector ports; open and reverse. DoorKing plug-in loop detectors only.
3. 9200-135 pedestal included.

## 9240 Slide Gate Operator

## Maximum Security Slide Gate Operator

### Operators w/#80 Chain

---

9240-380 3 HP, 208V 3° (9.8A).....	13,656.00
9240-381 3 HP, 230V 3° (9.6A).....	13,656.00

### Choose Entrapment Protection (required) Devices

---

*Use Type B1 (non-contact) and/or Type B2 (contact) entrapment protection devices to protect all areas where the risk of entrapment exist - see Section A1, pages 42-43.*

**Operator will not run without entrapment protection device(s) connected to the controller board.**

### Loops and Loop Detectors

---

*See section A1, page 44 for a complete list of all loop detectors, prefabricated loops and loop accessories available.*

### Accessories

---

2601-270 Chain Tray Kit 10 Ft (3m).....	418.50
1601-197 Heater Kit 208/230 VAC <sup>1</sup> .....	Note 2
<i>1. Use if temperature routinely falls below 10°F (-12°C).</i>	
<i>2. See Section A1, page 31 for pricing.</i>	

### Chain

---

2601-268 #80 Chain, 10-Ft (3 m).....	259.50
2601-269 #80 Chain, 20-Ft (6 m).....	522.00

## 9500 Series

### Heavy-Duty Maximum Security Slide Gate Operators

- Plug-in Loop Detector Ports
- Built-in power and reset switches
- Two 115 VAC convenience outlets
- Partial open / anti-tailgate feature
- Variable Speed
- 20-Feet (6m)
- Gate tracker data output
- Selectable stop/ reverse function

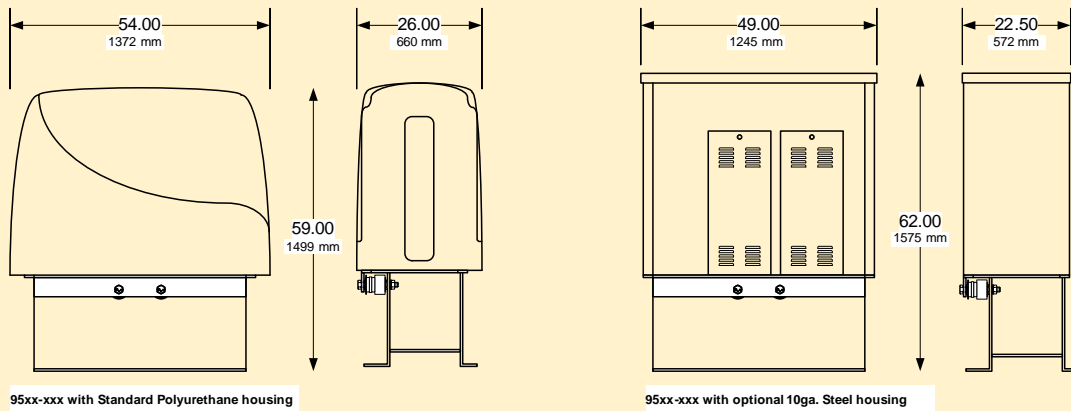

Model	Chain	Speed Variable	Maximum Gate Weight	Maximum Gate Length	Minimum Gate Length	Class of Operation <sup>1</sup>	Voltage VAC	HP	Gearbox Ratio	Power Outlets	Loop Ports <sup>2</sup>
9530	#80	1-2 Ft/sec .3-.6m/sec	8000 Lbs <sup>3</sup> 3628 Kg	160 Ft 48m	25 Ft 7.6m	III, IV	208, 230, 460	3	30:1	2	2
9550	#100	1-2 Ft/sec .3-.6m/sec	15,000 Lbs <sup>3</sup> 6803 Kg	160 Ft 48m	25 Ft 7.6m	III, IV	208, 230, 460	5	30:1	2	2
9555	#80	1-2 Ft/sec .3-.6m/sec	10,000 Lbs <sup>3</sup> 4535 Kg	160 Ft 48m	25 Ft 7.6m	III, IV	208, 230, 460	5	10:1	2	2
9575	#100	1-2 Ft/sec .3-.6m/sec	25,000 Lbs <sup>3</sup> 11,339 Kg	160 Ft 48m	25 Ft 7.6m	III, IV	208, 460	7.5	30:1	2	2

1. III = Limited Access; IV = Restricted Access
2. Plug-in loop detector ports; open and reverse. DoorKing plug-in loop detectors only.



## 9500 Series

### Heavy-Duty Maximum Security Slide Gate Operators

#### 9530 Operators w/#80 Chain

9530-380 3 HP, 208V 3° (9.8A).....	Call for Price
9530-381 3 HP, 230V 3° (9.6A).....	Call for Price
9530-382 3 HP, 460V 3° (4.8A).....	Call for Price

#### 9550 Operators w/#100 Chain

9550-380 5 HP, 208V 3° (12.9A).....	Call for Price
9550-381 5 HP, 230V 3° (12.8A).....	Call for Price
9550-382 5 HP, 460V 3° (6.4A).....	Call for Price

#### 9555 Operators<sup>1</sup> w/#80 Chain

9555-380 5 HP, 208V 3° (12.9A).....	Call for Price
9555-381 5 HP, 230V 3° (12.8A).....	Call for Price
9555-382 5 HP, 460V 3° (6.4A).....	Call for Price

<sup>1</sup> These operators include a mechanical disc braking system. A brake auto-release can be factory ordered with this operator.

#### 9575 Operators w/#100 Chain

9575-380 7.5 HP, 208V 3° (23.0A).....	Call for Price
9575-381 7.5 HP, 230V 3° (22.6A).....	Call for Price
9575-382 7.5 HP, 460V 3° (11.3A).....	Call for Price

#### Choose Entrapment Protection (required) Devices

9500 Series operators require a minimum of one (1) Type B1 AND one (1) Type B2 in EACH direction of travel. See Section A1, pages 42-43.

Operators will not run without entrapment protection devices connected to the controller board.

#### Loops and Loop Detectors

See section A1, page 44 for a complete list of all loop detectors, prefabricated loops and loop accessories available.

#### Accessories

2601-270 Chain Tray Kit 10 Ft (3m).....	418.50
1601-197 Heater Kit 208/230 VAC <sup>1</sup> .....	Note 2
1601-198 Heater Kit 480 VAC <sup>1</sup> .....	Note 2
9550-205 10 Ga. Steel Housing <sup>3</sup> .....	Call for Price

1. Use if temperature routinely falls below 10°F (-12°C).

2. See Section A1, page 31 for pricing.

3. Special order. Contact the factory for lead time.

#### Chain

2601-268 #80 Chain, 10-Ft (3 m).....	259.50
2601-269 #80 Chain, 20-Ft (6 m).....	522.00
2601-272 #100 Chain, 20-Ft (6 m).....	568.50

## **Blank Page**