

## Trolley Lift



- **Up to 15 metres Travel**
- **Self Supporting Structure**
- **Minimal Pit Required**
- **Variable Car Sizes**
- **Robust Design**
- **100-300kg Load Capacity**
- **No separate machine room required**

Niche..... Our passion and purpose is the supply of specialist lifts that enable wheelchair users and the less able gain access to upper floors and up stairways, plus service, trolley and goods lifts for transporting goods in the range 5kgs to 2000kgs

We supply, install and service Niche products that meet your specific needs.

NICHE LIFTS—Focus and expertise working uniquely for YOU on Niche Products.

# Trolley Lift

<b>Model Type</b>	Trolley lift
<b>Rated Load</b>	100, 200 or 300kg capacity.
<b>Rated Speed</b>	0.25 m/s
<b>Drive Type</b>	Traction or chain drive depending on duty, machine above
<b>Number of Stops</b>	Up to 6 stops
<b>Power Supply</b>	415v, 3 phase, 50hz, 4-wire
<b>Travel</b>	Up to 15 metres
<b>Pit</b>	Nominal 350mm deep pit can be reduced to 200mm.
<b>Headroom</b>	2600 (Door Height +1360)
<b>Controls</b>	Call and send buttons at each landing. Lift in use, car position indicator and door open buzzer at each landing.
<b>Configuration</b>	Single entry or through car.
<b>Door Type</b>	Swing hinge doors on landings. Galvanised finish.
<b>Shaft Enclosure</b>	Standard freestanding structure clad by others. Note structure requires horizontal ties to the building fabric. Galvanised non fire rated cladding can be provided
<b>Car</b>	Galvanised car with option of drop bar or lattice gate. Safety gear available upon request if there is accessible space below the lift shaft.
<b>Special Items</b>	Light & socket in the machine room, lift arrival buzzer and lift out of use indicator.
<b>Options</b>	Stainless Steel Finishes Fire Rated Landing Doors Adjacent Entry Variable car sizes (500-1000 wide x 600-1000 deep x 800-1200 high) Reduced headroom and under bar configurations
<b>Compliance</b>	EN81.3 EC Machinery Directive 2006/42/EC
<b>Documentation</b>	Owners guide issued on completion.

Arrangement	Car Width	Car Depth	Internal Car Depth	Door Opening Width	Car Height	Shaft Width	Shaft Depth
Front Loading with Car Drop Bar	1000	1000	960	960	1200	1350	1100
Through Loading with Car Drop Bars			920				
Front Loading with Car Lattice Gate			1000	800			1210
Through Loading with Car Lattice Gates			1310				

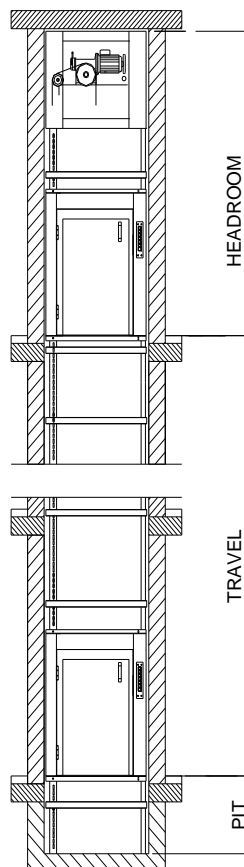
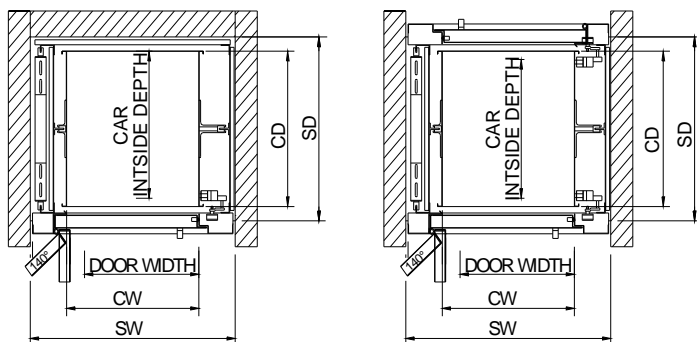

**Niche**<sup>TM</sup>  
Lifts

Niche Lifts Ltd  
Office 15-16  
12 Farwig Lane  
Bromley, Kent  
BR1 3RB

Tel 020 8295 2852  
Fax 020 8466 1695



Configure your lift on-line at [www.nichelifts.com](http://www.nichelifts.com)

The information contained in this brochure was correct at the time of printing, due to continued development of our products we reserve the right to change the specification without prior notice