

The Quest for Energy Efficiency



Abstract

One of the most widely discussed issues throughout the world today is the rapidly increasing price and demand of energy supply. Along with this comes the broadening awareness of the environmental impact and depletion of fossil fuels, which has created a natural drive towards energy saving and the widely encouraged use of new renewable energy, energy conservation best practices, and the development and advancement of energy efficient standards, processes and technologies.

As a consequence of the increasingly degrading environmental conditions, a strong sense of uncertainty regarding the future of energy supply has led to a global energy saving quest. At the forefront of this are the industries whose operations substantially contribute to the overall energy consumption as a consequence of their constant, yet crucial power requirements. The dependability of today's businesses on a reliable power supply puts them under pressure to search for ways to drive down their energy consumption, whilst at all costs avoiding real threats to the business continuity of their critical loads. Where maximum uptime is paramount for many of these world leading organizations, the presence of a UPS is an indispensable prerequisite for a reliable power infrastructure able to achieve maximum load safeguarding and conservation. UPS systems provide uninterrupted power to electronic systems such as computer networks and servers, building management systems and security systems. UPS also protect against power outages which could potentially lead to a halt of operations, a loss of information, productivity and profit for businesses. Moreover, UPS systems provide clean power supply to the load ensuring that the poor quality of the public network electrical supply is minimized or entirely eliminated so as to avoid upstream disturbances. As a result, decreasing power quality combined with the quest for maximum energy efficiency are set to be the future benchmarks of a new generation of UPS: **outstanding reliability coupled with maximum energy efficiency for 100% uptime.**

The energy efficiency of a UPS is considered to be the ratio between the power entering the UPS versus the power exiting the UPS to supply power to the load. Whenever the current passes through the internal components of a UPS a certain amount of energy is dissipated as heat which results in energy losses. Additional energy is also consumed whenever the air conditioning operates to sustain the ideal environmental temperature of the installation. Whilst a certain amount¹ of energy losses are inevitable, it is evident that the reduction of UPS power consumption and the consequent increase of its efficiency will significantly contribute to lowering excess energy waste, and in turn maximize the overall running cost-saving of the energy bill. The savings accomplished 24 hours a day, 365 days a year over a five year period, would not only equal the purchase cost of a UPS but it would also actively contribute to reducing CO2 and other global warming emissions, ensuring the lowest environmental impact of the chosen power protection solution.

¹As asserted in the second law of thermodynamics, whenever energy is transformed from one type to another, a certain amount of it is dissipated as heat. In simple terms: for this reason car engines are hot while running, mobile phone batteries get hot when recharged and nuclear reactors require constant cooling.

The Optimum UPS Solution for Energy Efficiency

Having considered the unprecedented demand for energy conservation and the current available UPS technology, in terms of energy efficiency, we can conceive that the ideal UPS would be able to predict the entity of disturbances and faults on the network and adopt, in real time, the best solution to solve it, using the minimum energy required to give the best power quality to the load.

Chloride, a business of Emerson Network Power, has turned this ideal into a real concrete solution by creating the first comprehensive energy efficient UPS. Chloride Trinergy® is a revolutionary UPS that has been developed with the capability of constantly analyzing the electrical environment in which it operates and, upon assessing the input conditions and the characteristics of the load, is able to intuitively choose the perfect solution in terms of power continuity, conditioning and energy savings. This is possible given that the three existing UPS configurations widely accepted both by the UPS expert community and the International Electrotechnical Commission (IEC), are available for the first time in one single unit, which is fully compatible with all installations.

Maximum Power Control (VFI)

Allows the best power to be supplied to the load whenever the system detects that the electrical environment requires conditioning. In the event that a degrade of network conditions occurs and the monitored parameters are out of tolerance, the Maximum Power Control mode allows complete conditioning and supply to the load using the double conversion mode with an efficiency of more than 95%.

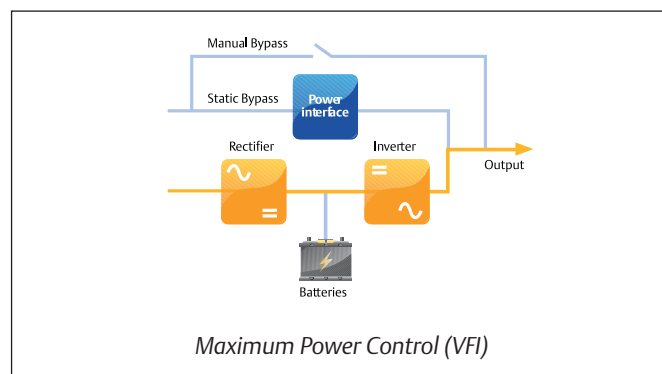

Maximum Energy Saving (VFD)

Detects when the mains energy supplied to the unit is of an ideal quality and the need for conditioning is limited. When network conditions are stable the Maximum Energy Saving mode is selected allowing the energy to pass through the bypass line, reaching an efficiency of 99%.

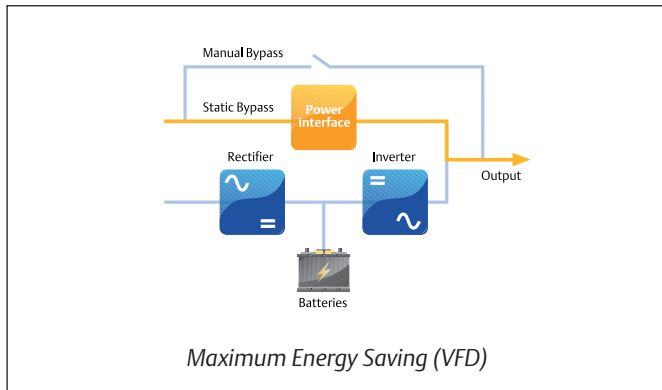

High Efficiency & Power Conditioning (VI)

Enables the system to condition the energy supply sufficiently without having to switch to the Maximum Power Control configuration. When a reactive load or non-linear load is connected to the UPS and harmonics or reactive current are present, Chloride Trinerigy® is able to compensate by operating as an active filter, and consuming only the necessary energy to compensate the line disturbances thus achieving the highest efficiency possible resulting in an efficiency variation of between 97% and 98.5%.

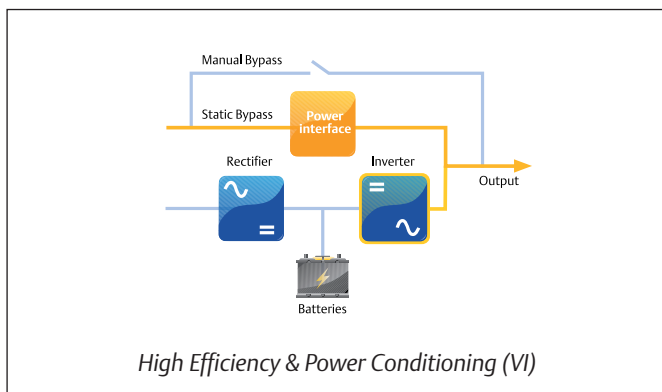

In conjunction with these three functioning modes Chloride Trinerigy® also harnesses the standard features fundamental to a high quality UPS. The exclusivity that sets Chloride Trinerigy® apart from other UPS is the combination of energy efficiency parameters, power continuity and exceptional performances present for the first time in one product:

- Maximum availability of the load;
- Optimum operating efficiency;
- Optimum power quality to the load;
- Full compatibility with any upstream source
 - Low input total harmonic distortion
 - High input power factor
- Maximum adaptability in supplying any load
- Proven compliance with installation and equipment standards

White paper - The Quest for Energy Efficiency

Data Center Case Study

In order to demonstrate the real energy saving advantages and simultaneous first-class performances of Chloride Trinerigy® we have compared it to the functioning of current available standard UPS technology performance in a large data center application.

Data centers depend on UPS to condition power and eliminate momentary outages, sags, surges, and other deviations from clean, in-phase power so as to ensure the continuity and security of the network in which they operate. So where does the energy go? Before reaching the IT equipment rack, electricity is first supplied to the UPS where it passes through the internal components and is cleaned before leaving the UPS to directly power the data center. The electricity consumed in this power delivery chain accounts for a substantial portion of the overall energy used to power a data center. In a typical data center installation the conditions of the network and the electrical features of the load mainly vary depending on the amount of traffic, resulting in power fluctuations and hence presenting different electrical load conditions to be protected by the UPS. In the given electrical environment the UPS influences the upstream distribution via the input power factor (PF) and the Input THDi (total harmonic current distortion). These electrical characteristics vary significantly, between 0.8 and 0.9 and from 6% to 20% respectively for PF and THDi, according to the fluctuations of the load, i.e., causing problems of harmonics and reactive current, thereby requiring different levels of conditioning. The UPS plays a fundamental role in conditioning the current drawn by the load as this helps avoid the reactive current and harmonics reaching the power sources, and potentially causing problems on the upstream equipment and the entire electrical network i.e. over heating of the transformer, accelerated ageing of components, necessity for cable over sizing and higher installation and running costs. Today the standard UPS that are commonly used in data centers guarantee high power quality and conditioning by working in double conversion mode. The double conversion mode converts power from AC (input power) to DC and from DC to AC (output power) providing a perfect output waveform regardless of the input quality. The drawback of constantly working in double conversion mode, i.e. even when the disturbances are only minor, is the unnecessary dissipation of excess energy. The ideal power conditioning solution for data center installations would therefore be one that is able to intuitively condition the current and harmonics, using the lowest amount of energy possible. Chloride Trinerigy® is in fact capable of functioning in a distinct Digital Interactive mode where the inverter works as a parallel active filter and therefore compensates the load THDi and PF. At the same time, Chloride Trinerigy® can function as a series active filter to improve the input window voltage tolerances, in the event of sags or over voltages, with a remarkable overall efficiency of up to 98%. Should major power conditioning be needed or a particularly serious network condition occur, Chloride Trinerigy® is capable of immediately reacting and maintaining the best power output quality by working in double conversion.

In conclusion, unlike the standard UPS, which works in double conversion mode regardless of the network conditions, Chloride Trinerigy® first monitors the environment operating conditions of the network before intuitively choosing the most efficient means of compensating disturbances, hence using only the necessary energy achieving a 4% to 7% greater efficiency than the standard UPS. Therefore guaranteeing a higher efficiency level while achieving the same high quality of power conditioning provided by the double conversion UPS.



A Real Installation

The exceptional advantage of Chloride Trinerger® is that it is able to discriminate between the different network input conditions and choose the best functioning mode, thus using only the necessary amount of energy required to provide the best output power quality and conditioning to the load.

To further understand the advantages deriving from this revolutionary architecture and to quantify the effective energy saving that can be obtained with Chloride Trinerger®, a simulation of the different UPS technologies available on the market has been performed. The credibility of simulations is dependent on whether or not real network conditions are taken into account, for this reason we carried out an analysis of the network data measured by the Chloride LIFE®.net remote monitoring and diagnostic service, a bi-directional, 24-hour year round communication system designed to remotely diagnose, monitor and manage the operational status of UPS and power distribution systems through its worldwide network. The data relating to the functioning of UPS in real network conditions corresponds with a sample of 2374 UPS monitored 24 hours a day, 365 days a year in the United Kingdom.

A 12 month Chloride LIFE®.net analysis carried out in 2008 proved that, on average, Chloride UPS protected organizations against:

- 2709 out of tolerance per UPS
- Out of tolerance average duration of 8 sec.
- 11 mains failures per UPS
- 120 sec. average duration mains failure

All of which could prove potentially harmful to the load.

The above results proved to be key when analyzed in conjunction with existing UPS technologies, made possible thanks to a dedicated simulator which was specially developed with a number of parameters including: network conditions, UPS architecture, efficiency, the UPS algorithm.

Given the availability of the real network data and the indication of the architecture, the simulation was performed and the average working efficiency of the UPS functioning in each of the operating modes was calculated. At the same time the simulation took into consideration the input power, thus allowing it to obtain the total energy dissipation over a one year period. The average efficiencies achieved are reported in the table below and used in calculating and comparing the energy saving of the three different technologies.

Standard existing technology

This typology of UPS with inverter transformer technology ensures efficiency at full load of around 92.5%. In a controlled environment installation with air conditioning, the energy dissipation at full load for one year is 8694 MWh.

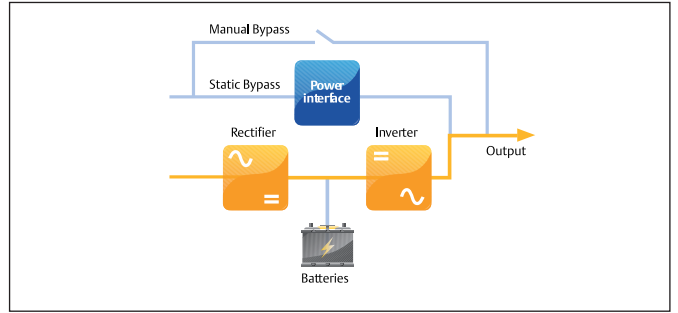

Best-in-class existing technology with eco mode

This typology of UPS with eco mode and intelligent double conversion greatly improves the working efficiency of the system, allowing it to reach up to 97%. A UPS working in intelligent double conversion, has an average working efficiency of 95% resulting in an energy saving of 220 MWh compared to the standard existing technology thus providing a significant cost saving.

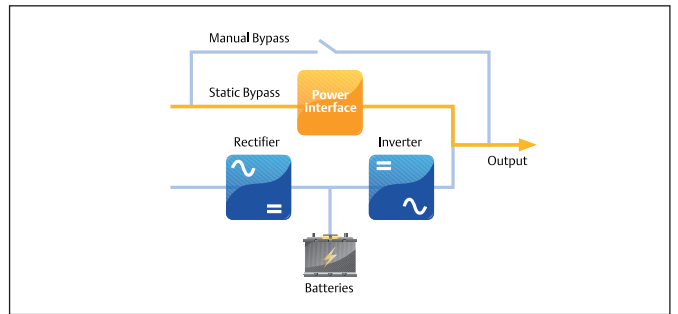

Chloride Trinerger® technology

Chloride Trinerger®'s newest revolutionary technology architecture demonstrates extraordinary advantages. Given the different conditions affecting the load, Chloride Trinerger® can intuitively choose the most convenient operating mode in order to use the lowest amount of energy while guaranteeing the perfect power quality and achieving up to 98% average working efficiency i.e. energy saving, cost saving and reduced environmental impact.

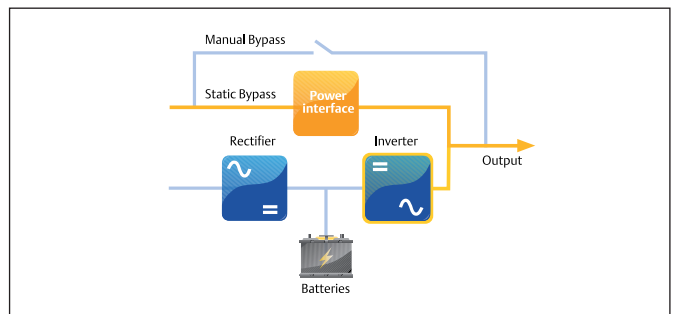

The table below shows a summary of the results of the comparison between the UPS working with each of the available technologies.

	Apparent Power kVA	Active Power kVA	Average Working Efficiency %	Input Power kW	Cooling Coefficient	Energy Dissipated kWh	Cost Of Energy €/kWh	Energy Saving kWh	Financial Saving per Year €
Standard existing technology (double conversion)	600	540	92.5	584	1.7	8693708	0.09		
Best-in-class existing technology (double conversion with eco mode)	600	540	94.9	569	1.7	8473846	0.09	219862	19788
Chloride Trinerger® technology	600	540	97.9	552	1.7	8214178	0.09	479530	43158

* Calculation model and calculation tool are described in the appendix.

Conclusion

In pursuit of securing any mission critical equipment and process we can conclude that to date we could choose between two principal technologies; the standard existing technology and best-in-class existing technology with eco mode.

Each of these widely accepted technologies has pros and cons with regards to energy efficiency.

When the standard UPS functions in double conversion mode it provides optimum load protection in all situations, being it a small voltage variation or a dramatic power failure.

In both cases the energy dissipated by the UPS is equal.

The question then is, would it be possible to have a UPS that is able to adapt to the two opposite network conditions individually but using less energy i.e. minimizing the energy dissipation during small voltage variation events?

The main limitation of a UPS with best-in-class technology and eco mode is that when working in eco mode the UPS is not able to perform any type of conditioning, not even for minor disturbances.

Moreover the inverter is unable to condition harmonics or compensate voltage variations thus needing to switch to double conversion mode (intelligent double conversion) in order to condition the load, which in turn results in a great amount of energy dissipation.

This can be further demonstrated by the data drawn from the Chloride LIFE[®].net remote monitoring and diagnostics service, which clearly demonstrates that the most frequent disturbances

present on the network are not total mains failures but, instead they are mainly minor out of tolerances, or variations of the network; therefore for a UPS working with best-in-class technology and eco mode the necessity to switch to double conversion mode to allow the maximum power control would be a very frequent occurrence.

The revolutionary technology of Chloride Trinerger[®] delivers enormous advantages:

Not only has the efficiency of each existing functioning mode been maximized but a new algorithm has also been created to enable the UPS to monitor the environment in which it operates and intuitively select the functioning mode to accordingly allow maximum load protection as well as maximum energy saving, whilst concurrently maintaining optimum UPS operating performances.

The unique proven efficiency of Chloride Trinerger[®] is not the only thing worth praising. Chloride Trinerger[®], thanks to the unique combination of technologies is also the best solution to date for minimizing operating costs.

In fact, as presented in our analysis, a UPS working in standard mode provides virtually no margin for energy or cost-savings as it permanently works in double conversion mode.

When comparing the standard technology with the one found in the best-in-class UPS with eco mode, both the energy and cost savings proved to be notable.

Finally, UPS working with Chloride Trinerger[®] technology, in which all the existing technologies are incorporated in one, proves to provide double the savings of a UPS working with best-in-class existing technology.

Appendix: Energy Saving Calculation Method

To be able to calculate the energy saving value of any given UPS we must first calculate the amount of energy dissipated by the individual unit.

The wide range of UPS currently available on the market all feature different technology hence each of them dissipates a different amount of energy.

To calculate the energy dissipation of a UPS we begin with the efficiency of the overall unit which is actually the expression of how much energy is dissipated by the system.

Formula: 1

$$\eta = \frac{P_u}{P_i}$$

The above formula; Efficiency equals: output active power, over input active power is used to obtain the efficiency of the UPS.

The energy saving can then be calculated as the difference between the energy dissipated by each UPS.

The energy dissipated (kWh) by the UPS over a one year period is obtained using the following formula:

Formula: 2

$$E(kWh) = P_i(kW) \times 365(\text{days in one year}) \\ \times 24(\text{hours per day}) \\ \times 1.7(\text{air conditioning coefficient})$$

For this formula the input power (Pi) can be calculated dividing the output active power by the efficiency. In addition an air conditioning coefficient of 1.7 has been applied to all systems for a more realistic result. In order to maintain a controlled temperature in a real installation an air conditioning system is usually necessary.

Of course the more energy dissipated by the UPS, the more heat it will expel and consequently the energy dissipated by the air conditioning system will increase.

To calculate the energy dissipation in our simulation we chose a 600 kVA UPS with an output active power of 540 kW.

In order to obtain the input power of the UPS and therefore calculate the energy saving we first needed to know the efficiency of each of the different technologies to be compared. A UPS with standard existing technology, working in double conversion mode and connected to a resistive load of 540 kW has a fixed efficiency value of 92.5%.

In order to obtain the values of the efficiency of the best-in-class existing technology and Chloride Trinergy® technology, we used a dedicated simulator as these technologies have different functioning modes which would have different efficiencies depending on the network conditions present.

This simulator allows us to calculate the energy saving that can be obtained with these technologies. Using the real network data we are able to input the efficiency, architecture and the algorithm of the best-in-class existing technology and Chloride Trinergy® technology UPS.

The simulator automatically calculates the average energy efficiency of the UPS by considering how much time the UPS will work in each different functioning mode based on the network conditions extracted from the Chloride LIFE®.net remote monitoring and diagnostic service. Running the simulation with the best-in-class existing technology means that the simulator calculates the average working efficiency of the UPS analyzing the input conditions and calculating over the whole year how much time the UPS works in double conversion mode and how much time it works in eco mode. Running the simulation with the Chloride Trinergy® technology we were able to calculate, based on the real network conditions inserted, the length of time the UPS would work in each of the different functioning modes and thus obtain the overall average working efficiency.

To conclude the energy saving value has been calculated as the difference between the energy dissipated by each UPS (calculated using the output active power of the load) and the average working efficiency obtained using the dedicated simulator.

Chloride
WORLD HEADQUARTERS

Via Fornace 30
40023 Castel Guelfo (BO)
Italy

T +39 0542 632 111
F +39 0542 632 120
E Enquiries.Chloride@Emerson.com

www.ChloridePower.com

Emerson Network Power.

The global leader in enabling *Business-Critical Continuity™*.

- | | | | |
|----------------|----------------------|--|-------------------------------|
| ■ AC Power | ■ Embedded Computing | ■ Infrastructure Management & Monitoring | ■ Precision Cooling |
| ■ Connectivity | ■ Embedded Power | ■ Outside Plant | ■ Racks & Integrated Cabinets |
| ■ DC Power | ■ Industrial Power | ■ Power Switching & Controls | ■ Services |