



Omega designs, manufactures and installs aluminium and PVC windows, doors, bi-fold doors, frames and patios in a wide variety of colours and configurations.

Our range of aluminium products is suitable for all types of residential and commercial applications and comes in strong and attractive slim-line profiles. We offer the complete range of windows, doors, bi-folds and patio doors, all designed whilst remaining practical and aesthetically pleasing to look at.

Our range of PVC products are amongst the most technologically advanced in Europe, being manufactured to high standards, incorporating thermally efficient profiles and energy rated double and triple glazed sealed units.

Alitherm 600 Window – Offers U-values as low as 1.4 W/m²K

The Alitherm 600 window system is suitable for domestic and commercial applications for new build projects and replacement windows for existing buildings. Extended polyamide thermal break help provide excellent U values.

- Open out casements and fixed windows with externally beaded sashes and externally beaded fixed frames
- Dummy sash used for internally beaded fixed frames
- Flat outer frame and chamfered vent
- Chamfered bead
- Espagnolette with bi-directional locking to BS7950 (not secure by design)
- Average U-value 1.7 W/m²K (28mm with 1.2 centre pane) – WER 'C'
- Average U-value 1.4 W/m²K (36mm with 0.7 centre pane) – WER 'C'

Features and Options

- Internally beaded chamfered sash option – 28mm & square bead only
- Externally beaded flat sash option – cockspur locking handles only
- Square bead for externally beaded option available – 28mm only – ETC665
- Fab & Fix slim-line handles – white, black, gold, chrome, satin chrome & bronze
- High quality EPDM gaskets and weather brushes to aid weather proofing
- Polyamide thermal barrier reduces heat loss and improves thermal performance
- Finishes available in KL, RAL, Sensation range and dual colour options
- **All designs are viewed from outside**
- Head vents are available in an additional 42mm frame extension

Applications

- Fixed windows
- Side hung open out casements
- Top hung open out casements
- **Angled frames, please note that double glazed angles are beaded with square bead**

Size Restrictions

- Large frames with mullions are subject to be split and coupled based on a design wind load of 800pa
- Maximum sizes will depend on wind loading requirements and style of window but indicative sash sizes with VITA (17mm stack height) friction stays are as follows:

Top Hung Sashes

- Max width: 1200mm
- Min width: 385mm (frame size 423mm)
- Max height: 1300mm (1500mm with Securistyle HD stays)
- Min height: 200mm (frame size 238mm)
- Max weight: 50kg

Side Hung Sashes

- Max width: 700mm
- Min width: 320mm (frame size 358mm)
- Max height: 1400mm
- Min height: 385mm (frame size 423mm)
- Max Weight: 24kg
- 450mm opening (fire escape) - frame/frame min 637mm - frame/mullion CL min 611mm

Weather Performance (BS6375-1)

- BS EN 1026: 2000 Air Permeability: Class 4 600 Pa
- BS EN 1027: 2000 Water tightness: Class E 1200 Pa
- BS EN 12211: 2000 Resistance to Wind Load: Class E 2400 Pa

Lead Times

- Lead times vary depending on the colour of the aluminium you select
 - Stock colour white (KL009) is available in the shortest time
 - KL and Sensation colours are on slightly longer lead times
 - Dual colours are on the longest lead time

Information on Colour

- Below is our standard range of KL colours. Please be aware that these colours come in different surface finishes as indicated below. These colours can be applied the same to both sides of the profile or you can mix and match and choose different colours for inside and out, referred to as dual colour.



- We also offer a range of colours called "Sensation", these combine unique colours and textures. Below is just a sample, please ask to see the full range.



- We also offer a range of non-textured wood effect colours, please ask to see the full range of finishes, again these can be mixed and matched with any of the other colours above. Note aluminium wood effects do not match Upvc wood effect finishes.



Please note that these colours are intended as a guide only. The paint finish is guaranteed for 25 years except in hazardous environments, e.g. within 500 metres of the high tide line, swimming pools and marine environments. In these cases you need to apply to us/Smarts to confirm the exact length of guarantee.

Cross Sectional Drawings

Standard Frame & Sash Detail

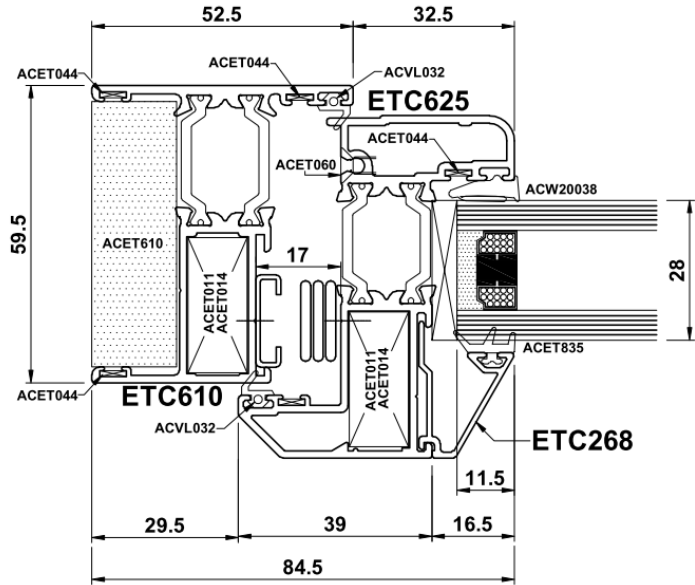
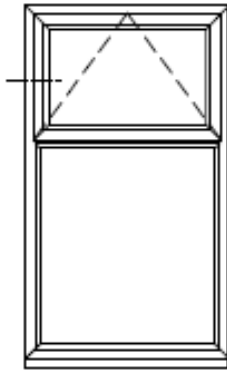

Standard Outer Frame

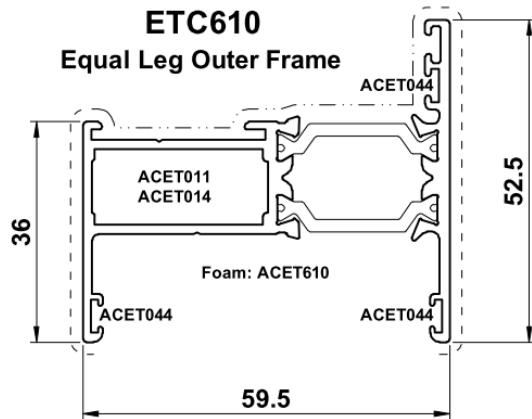

Short leg Outer Frame option

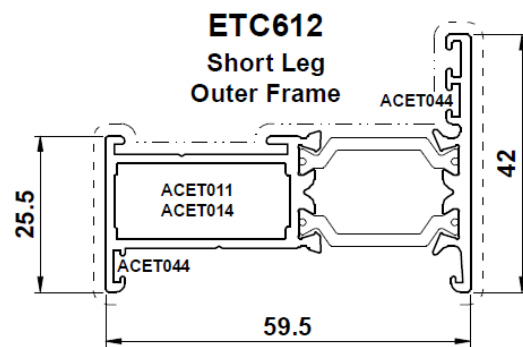

Odd Leg Outer Frame

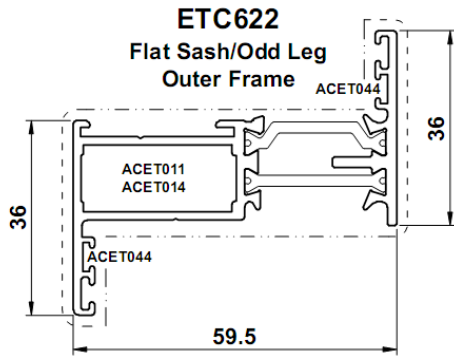

Can be used as sash – externally beaded – Cockspur locking only

Curtain Walling Outer Frame Insert

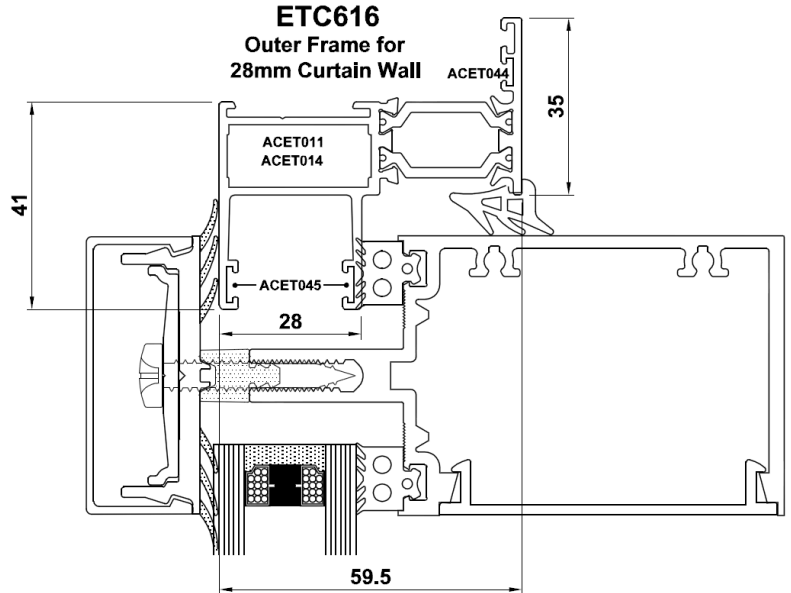

Standard Sash (externally beaded)

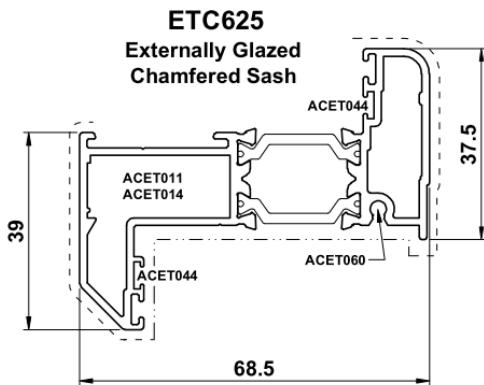

Chamfered Sash (Internally Beaded)

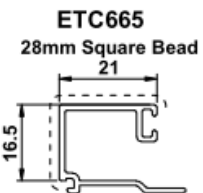
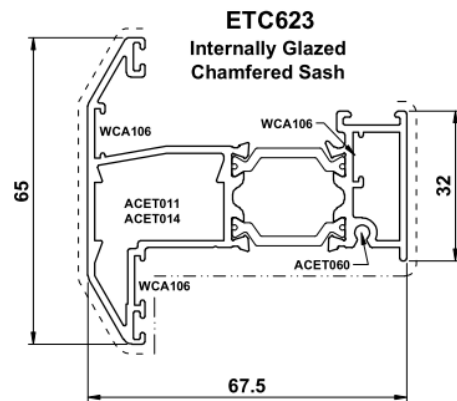

Square bead option.

On angle frames that are double glazed ETC665 used.

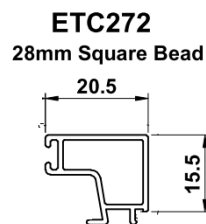

Internally beaded sashes only available with Square bead ETC272

Standard Transom/Mullion
(Ovolo tran/mull not available)

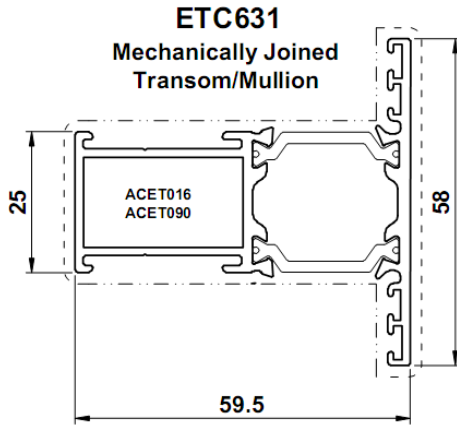

ETC656N 61mm x 42mm Extension for ETC610 & ETC612
(Small lip is noticeable to the front as this extension is 1.5mm wider than the outerframe)

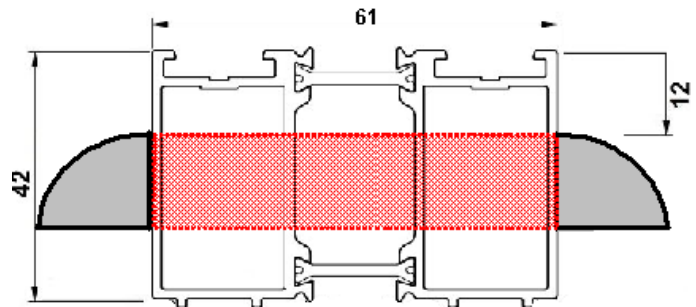

Note:

With the hood of the head vent fitted there is approx. 12mm to the outer edge of the 42mm head extension. Extensions come fitted to outer frame and pre-routed.

90° Corner Post ETC655 for ETC610 & ETC612

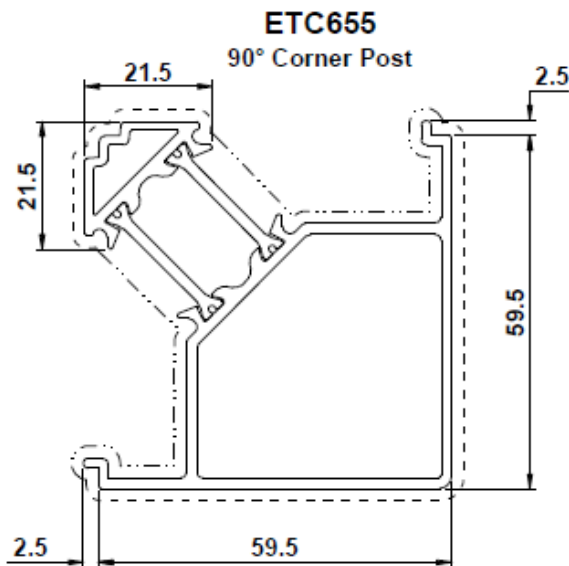

ETC660 59.5mm x 15mm Extension for ETC610 & ETC612

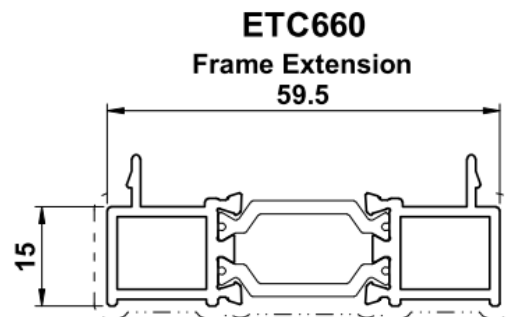

ETC517 180° Coupler
(25mm deduction)

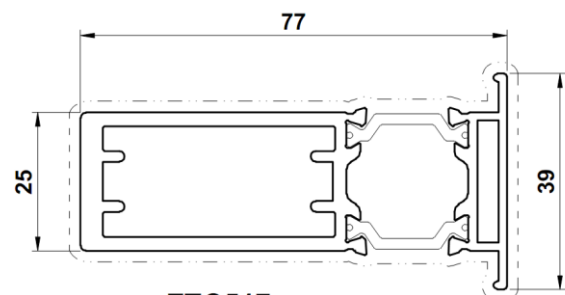

ETC517
Coupler

ETC869 Bay Pole for ETC610 59.5mm frame

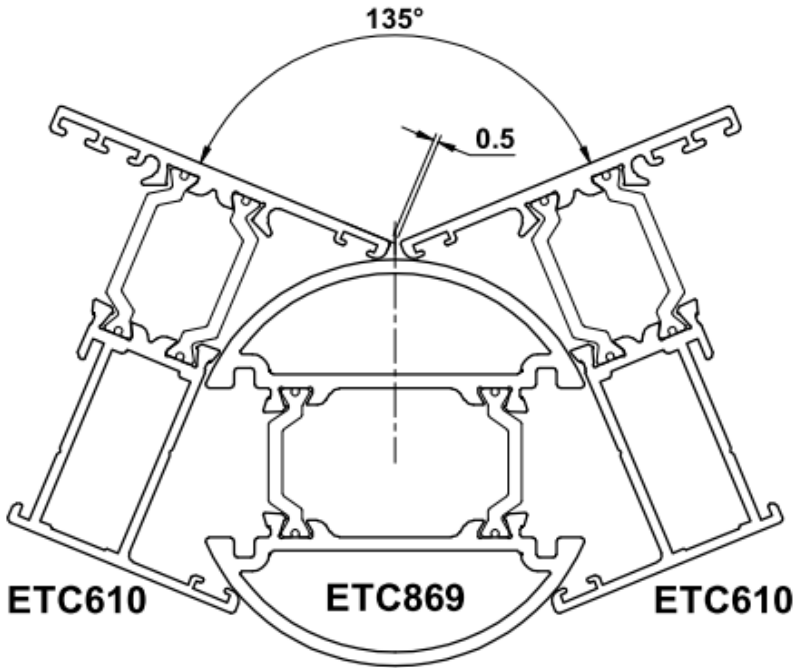

| ANGLE | DEDUCTION 'A' |
|-------|---------------|
| 180° | 13 |
| 175° | 11.5 |
| 170° | 10.5 |
| 165° | 9 |
| 160° | 8 |
| 155° | 6.5 |
| 150° | 5 |
| 145° | 3.5 |
| 140° | 2 |
| 135° | 0.5 |

ETC869 Bay Pole with ETC650 frame adaptors for ETC612 59.5mm frame

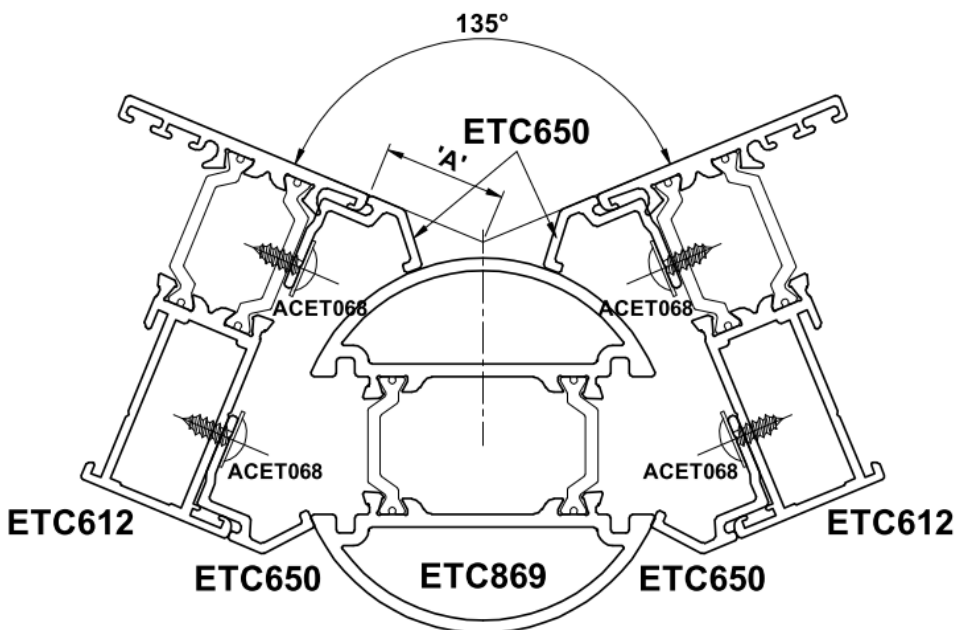

| ANGLE | DEDUCTION 'A' |
|-------|---------------|
| 180° | 32 |
| 175° | 30.5 |
| 170° | 29.5 |
| 165° | 28.5 |
| 160° | 27 |
| 155° | 25.5 |
| 150° | 24 |
| 145° | 23 |
| 140° | 21.5 |
| 135° | 19.5 |

Alitherm 600 French Escape Windows

There is no option on the 600 series for a double handle French escape window.

The only option available is for single handle gearing to the master and a finger operated bolt to the slave sash, as shown in the drawing.

Parts

- ETC648 False mullion
- ACET648 False mullion end caps
- ACW20432 Finger bolt keeps
- ACET646 Finger Bolts

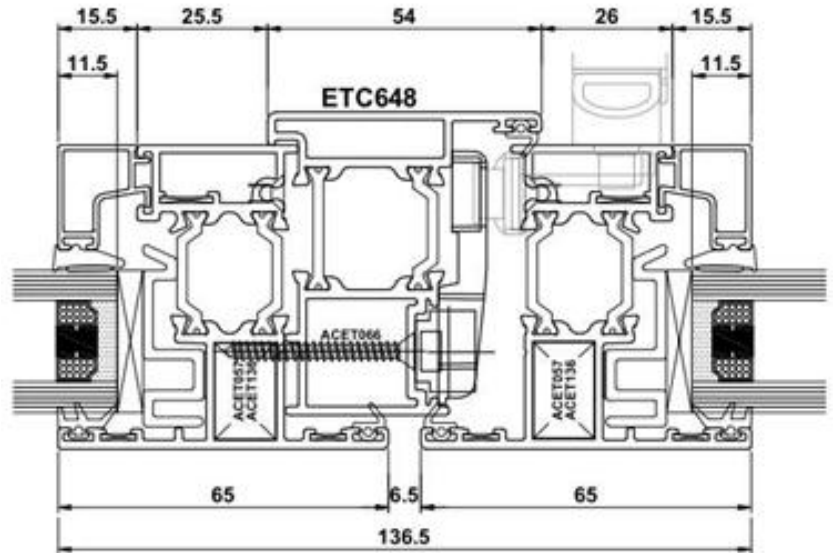

French escape windows are available with the ETC625 Externally beaded and the ETC625 Internally beaded sashes

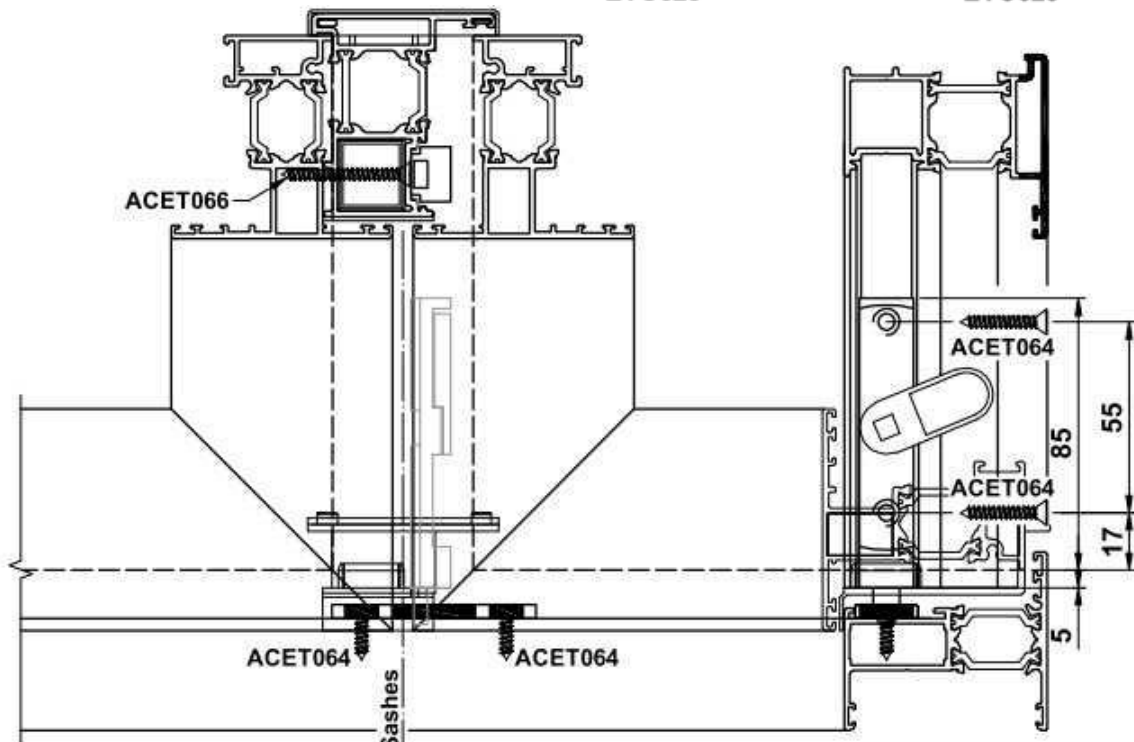
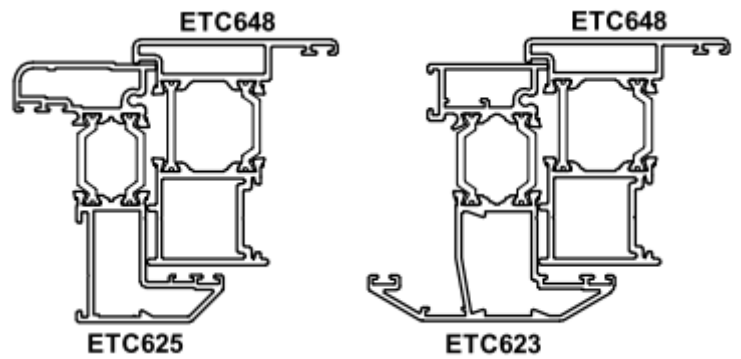

Cills / Mitred Cills

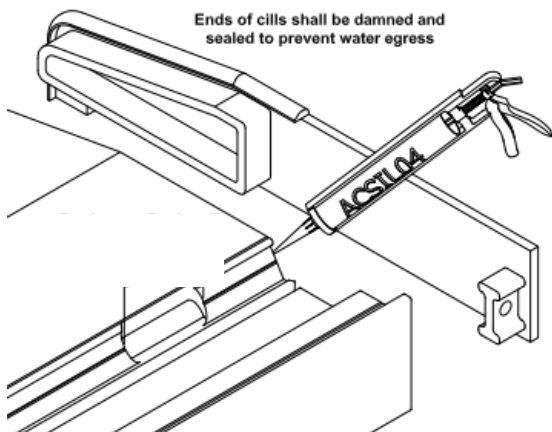
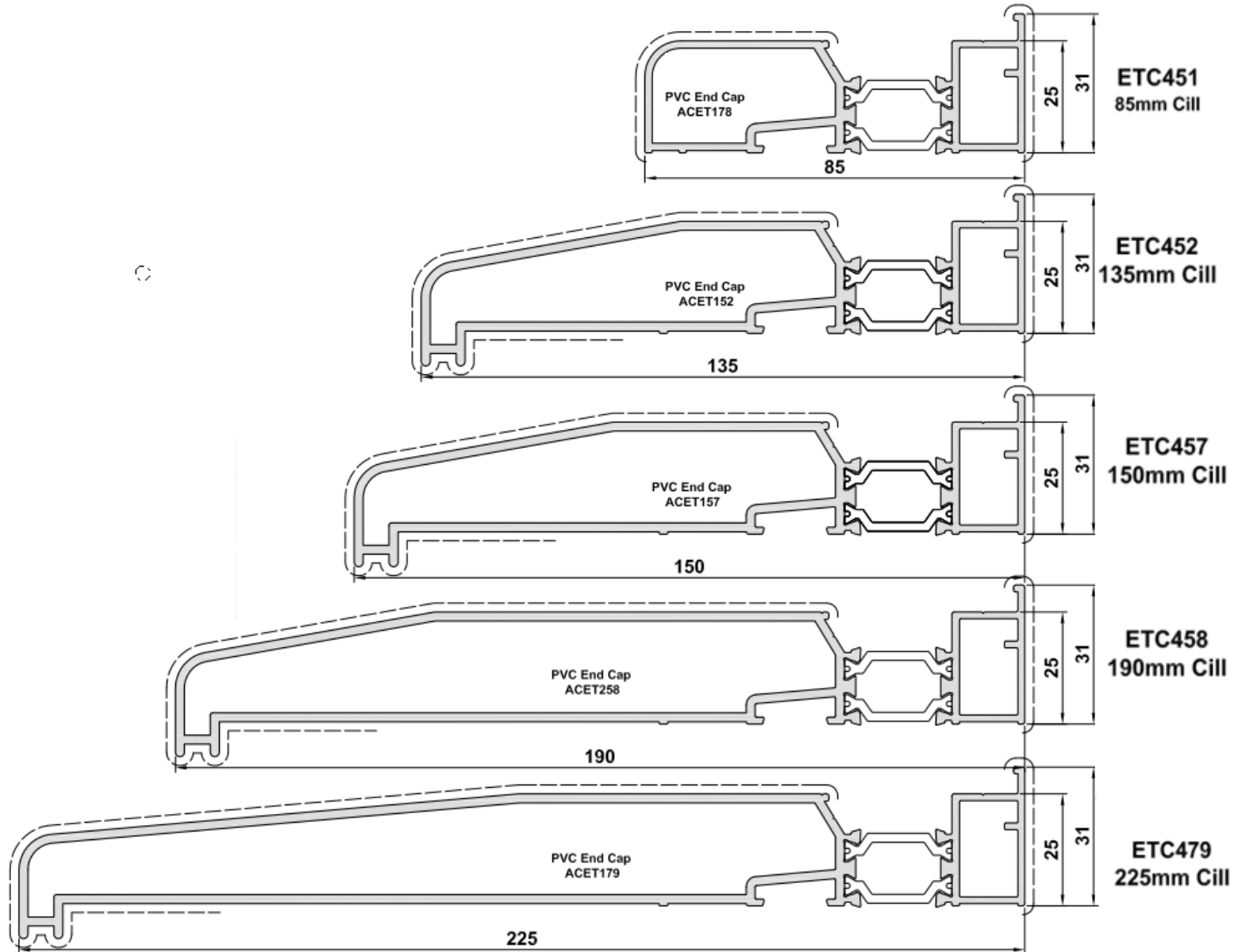

Please Note

All cills are factory drained and should have cill end caps fitted prior to installation, sealing the cill end caps to the cill with silicone to prevent water egress (do not cut the end caps and fit after installation as this will result in water penetration and invalidate guarantee).

End caps are PVC and not colour matched to frames. White and black available.

Example Lug Fixing Detail

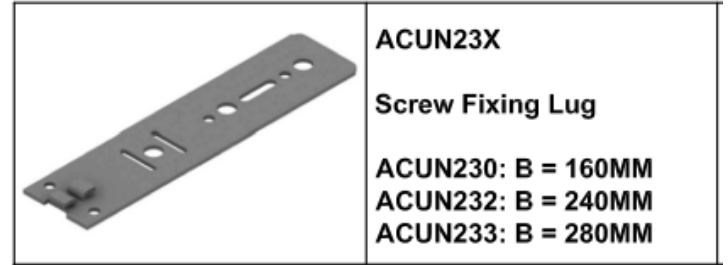
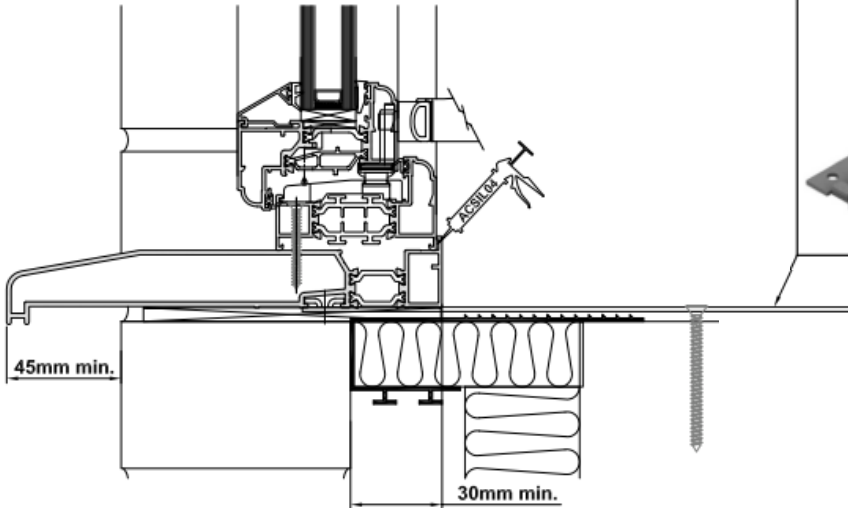

Example Direct Fixing Detail

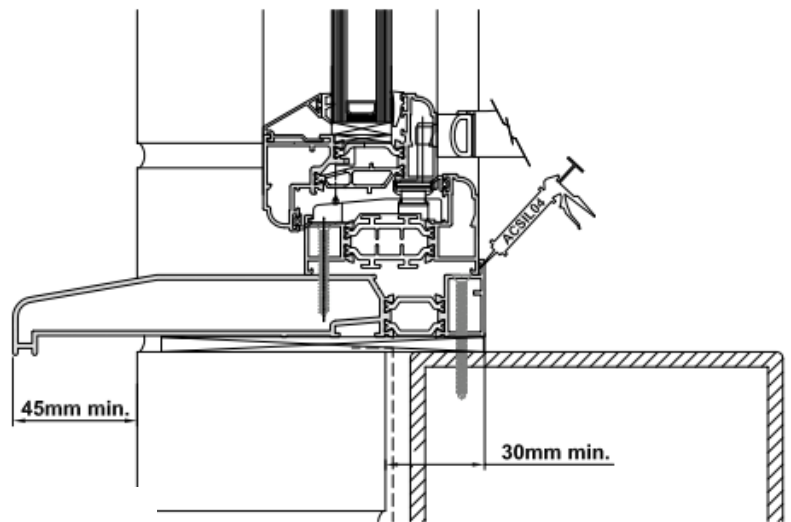

Please Note

Cill fixing lugs need to be ordered separately they are not included with cills – pack size: Qty 100

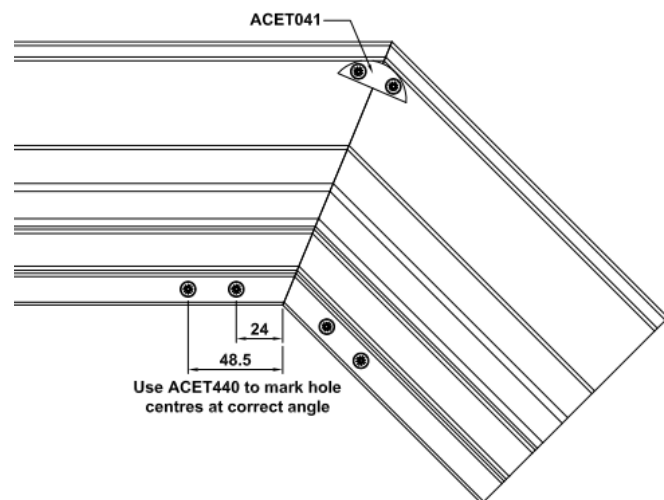
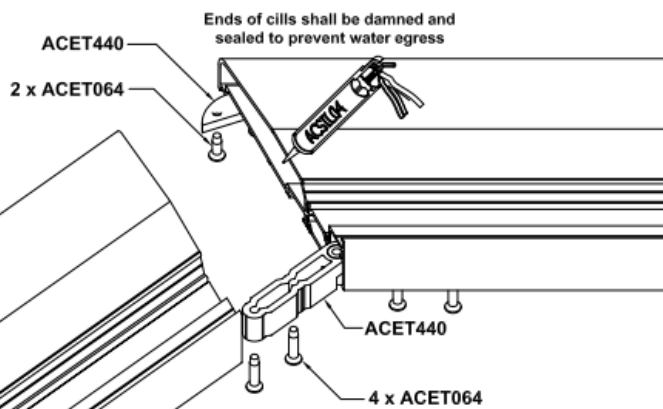

U-values for Double Glazed Units

Our standard glass specification is:

- 28mm double glazed units
- 4mm Planilux clear +/4mm Planitherm
- 90% argon gas filled cavity
- 20mm Grey super spacer bar
- 20kg per m²
- 1.2 W/m²K centre pane

Standard 59.5mm Frame ETC610F with Sash ETC625 and Mullion ETC631

Average U-value of 1.7 W/m²K - WER 'C'

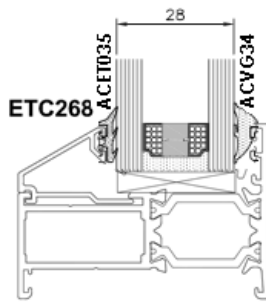

Flat 59mm Frame ETC610F

with Sash ETC623 and Mullion ETC631

Average U-value of 1.8 W/m²K - WER 'C'

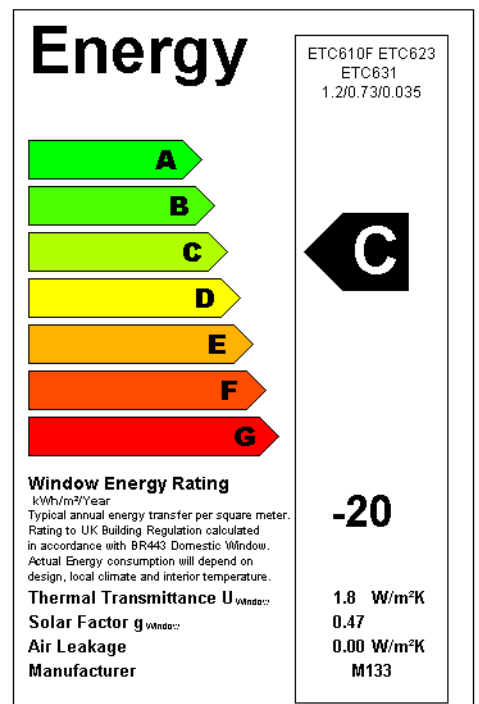
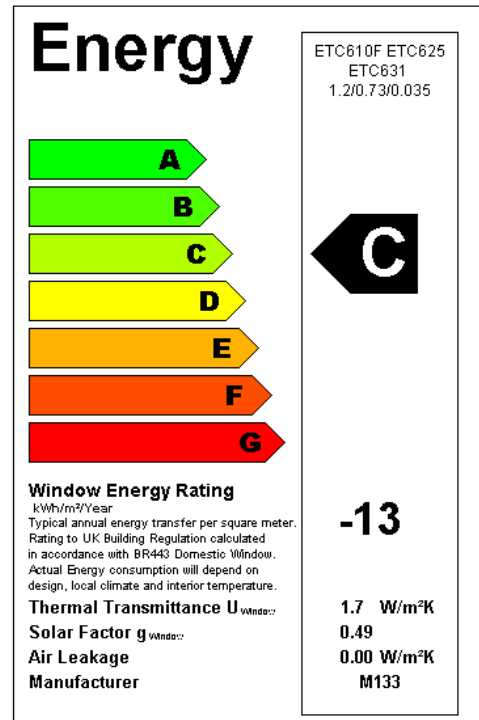
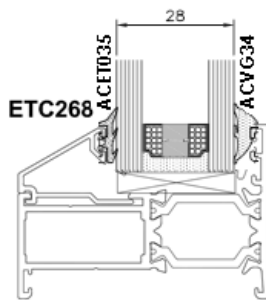

U-values for Triple Glazed Units *(not available on internally beaded sashes)*

Our standard glass specification is:

- 36mm triple glazed units
- 4mm Planilux clear +/4mm Planitherm +/4mm Planitherm
- 90% argon gas filled cavity
- 12mm Grey super spacer bar
- 30kg per m²
- 0.8 W/m²K centre pane

A window energy rating of WER 'B' - 1.4 W/m²K is available using the following unit:
4mm Diamante +/4mm Planitherm +/4mm Planitherm

Standard 70mm Frame ETC610F

with ETC625 and ETC631 Transom

Average U-value of 1.4 W/m²K - WER 'B'

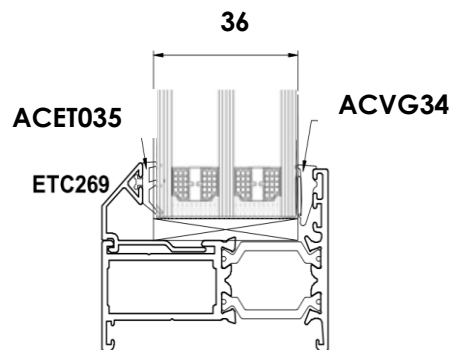
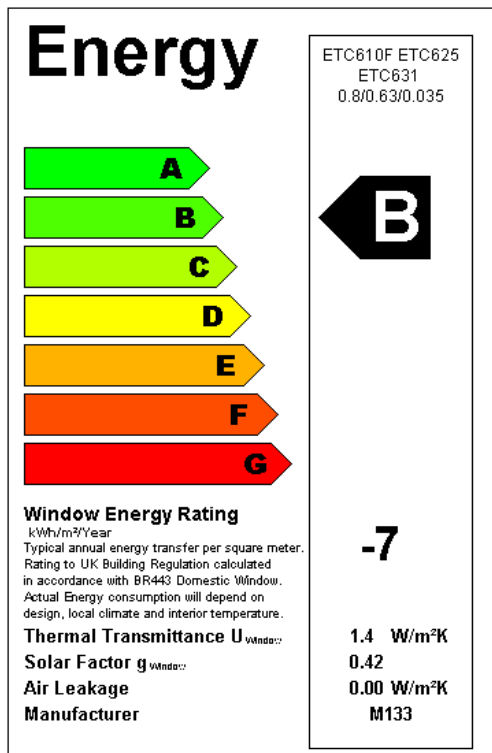

You will need to specify at the point of quote/order if you want the triple glazed option otherwise your frames will be processed with the standard double glazed option.

Installation of Aluminium Windows and Doors

Care should be taken to ensure that you make allowance for the expansion and contraction of the frame, the aperture tolerances and the thickness of any silicone or mortar bed at the sub-sill. The following table should be used as a guide.

| Material | Recommended deduction for width or height of structural opening | | | |
|-------------------|---|---------------------|-----------------------------------|--------------------------|
| | Up to 1.5 m | From 1.5 m to 3.0 m | From 3.0 m to 4.5 m ^{A)} | Over 4.5 m ^{A)} |
| GRP | 5 | 10 | 15 | 15 |
| PVC-U – white | 10 | 10 | 15 | 20 |
| PVC-U – non-white | 15 | 15 | 22 | 28 |
| Timber | 10 | 10 | 10 | 15 |
| Steel | 8 | 10 | 12 | 15 |
| Aluminium | 10 | 10 | 15 | 20 |

NOTE 1 These deductions are from the total width or height, and are not “per side”.

NOTE 2 The gap required for effective polyurethane foam fixing at the head is 10 mm to 15 mm.

NOTE 3 When fitting aluminium or steel frames into existing timber sub-frames, deduct 4 mm.

^{A)} Intermediate expansion joints might be needed when the width or height exceeds 3 m.

When fixing the frames ensure that all four sides are secured as follows.

- Corner jamb fixings should be between 100 mm and 150 mm from the external corner.
- No fixings should be less than 100 mm from the centre line of a mullion or transom.
- Intermediate fixings should be at centres no greater than 600 mm.
- There should be a minimum of two fixings on each jamb.

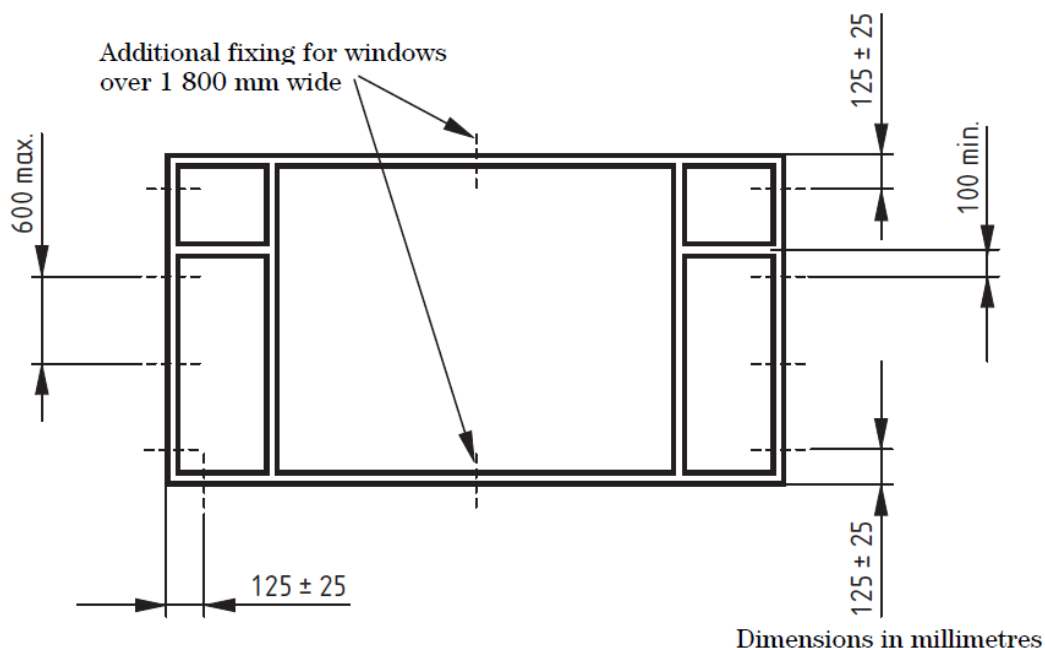

- On windows and door-sets over 1800 mm wide, central head and sub-sill fixings should be provided.
- Cills are fixed in the correct locations (i.e. not through the drainage chamber)
- Full length end caps are fitted and sealed to all cills

When building up components on coupled frames, care should be taken to keep coupling joints equal, and frames both aligned and plumb. Coupled assemblies should be fastened together in accordance with the manufacturer's instructions. Where the coupling is structural, the system supplier's recommendations should be followed.

Care should be taken to ensure windows and door-sets are installed plumb and square within the aperture, without twist, racking or distortion of any member in accordance with the manufacturer's recommended tolerances, to operate correctly after installation.

Installation packers should be used adjacent to fixing positions to prevent outer frame distortion during installation. Installation packers should be resistant to compression, rot and corrosion. They should span the full depth of the outer frame. The fixings should be tightened so that the frame is held securely against the packers. Over-tightening can lead to distortion and should be avoided. Some lugs need to be packed off the substrate to prevent distortion. Where enhanced security is required, additional packers might be necessary adjacent to hinge and locking points.

Insulating glass units, setting and location blocks, distance pieces, frame to glass and bead to glass gaskets, bead to frame air seals, corner sealing blocks, beads and bead end caps, bedding and capping sealants should be installed in accordance with BS 8000-7.

Glazing

Please ensure that you glaze the products in accordance with these guidelines.

Failure to glaze the products correctly, especially doors will lead to operational problems.

Any site visits required to adjust doors that have not been glazed correctly will be chargeable.

