

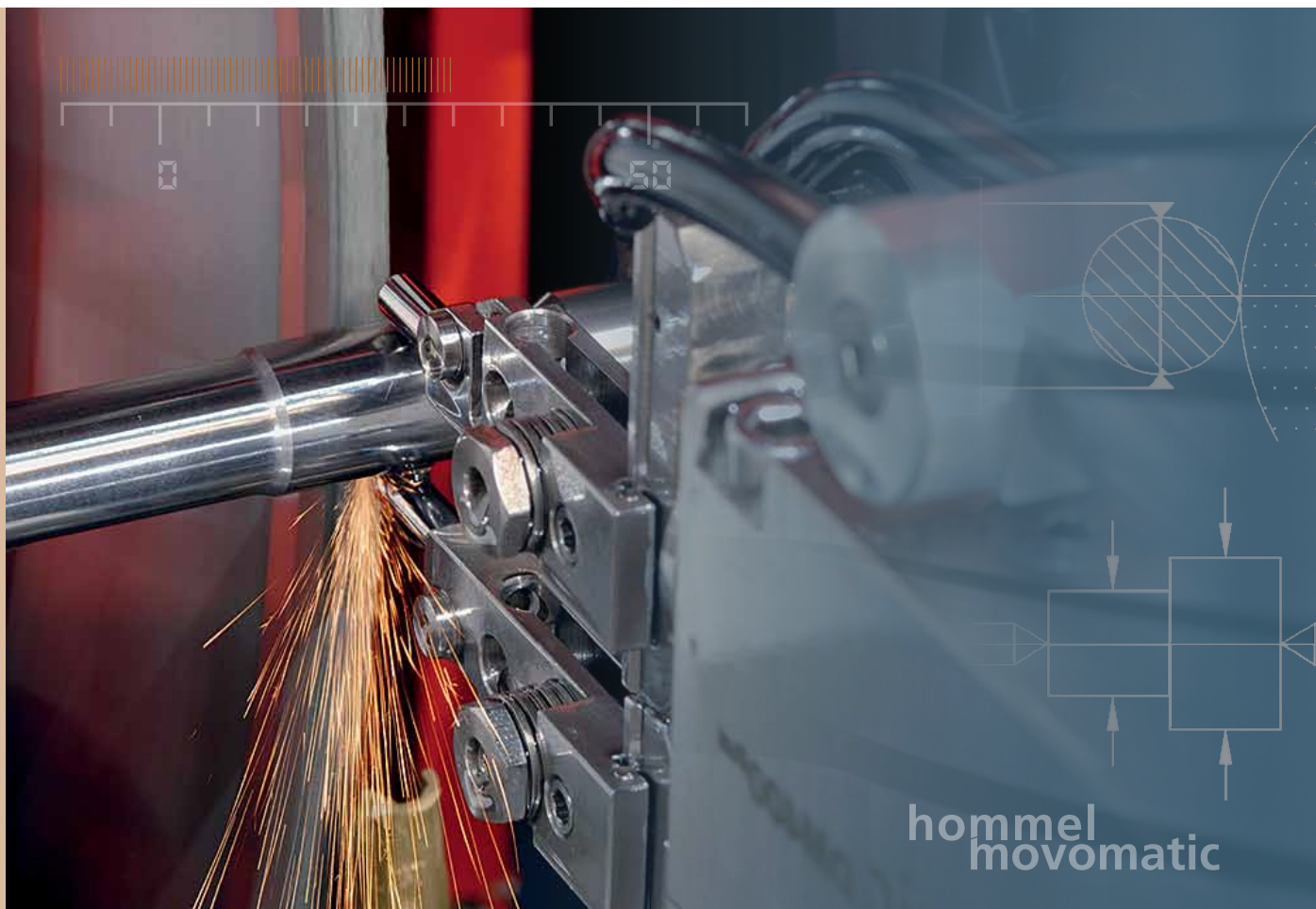

MOVOLINE

In-Process Metrology



Your partner for measuring solutions

We deliver solutions that help you optimize your manufacturing process regarding qualitative and economic objectives.

We, the Industrial Metrology Division of the Jenoptik Group, are one of the leading international specialists in high-precision, tactile and non-tactile production metrology.

Our services range from complete solutions for different measuring tasks such as the inspection of surface and form as well as determining dimensions, throughout every phase of the production process including final inspection or in the metrology lab.

Our decades of experience in tactile, optical and pneumatic measurement combined with our global sales and service support network brings us close to you, our customers, enabling us to provide optimal support as a reliable partner.

Our team is looking forward to your inquiry!

Jenoptik – Sharing Excellence

Model	Brief description	Page
In-process applications	Examples with different measuring tasks	6 - 9
Digital gage heads	For diameters, length and position	10 - 11
Measurement controls	Different models, depending on the measuring task	12 - 13
Measuring systems for crank shafts	For diameters and roundness	14 - 15
Pre-/post-process applications	Examples with different measuring tasks	17 - 18

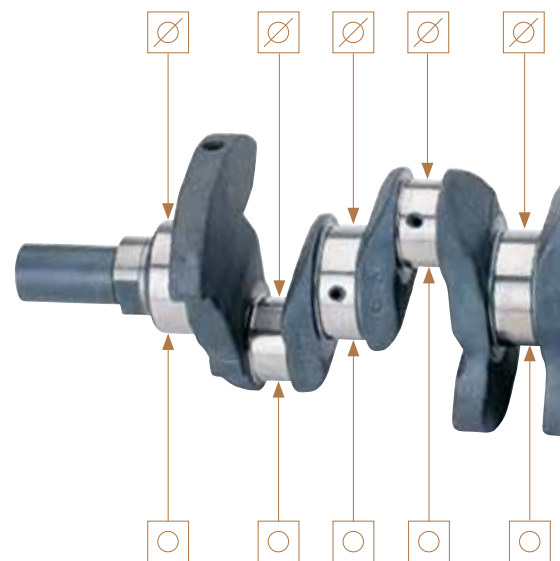
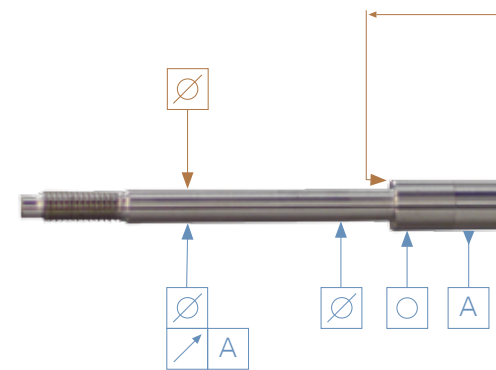
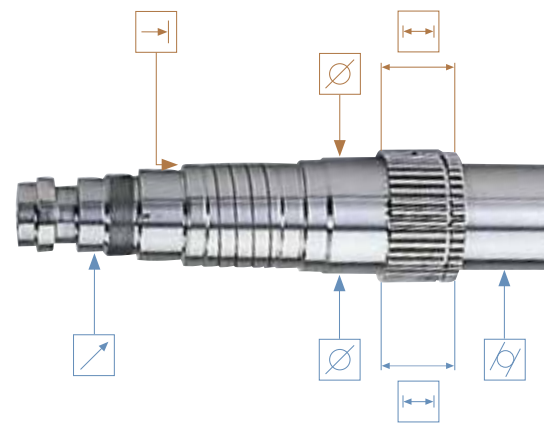

Professional in-process metrology

MOVOLINE measuring solutions offer a wide field of applications for in-process measurement. Thanks to the continuous measurement of the workpieces during the actual grinding process in the working space of the machine, the grinding process can be controlled and optimized dependent on the measured parameters.

Successfully implemented worldwide

- Shafts
- Turbo-chargers
- Pistons
- Injector components
- Hydraulic valves

Use for

- Cylindrical grinding
- Internal grinding
- Match grinding
- Flat grinding

Parameters measured in-process

- Plain outer diameters
- Interrupted outer diameters
- Inner diameters
- Active and passive axial positioning
- Length

Pre- and post-process metrology

MOVOLINE solutions are also used in pre- and post-process measurements, before or after the actual process step, for example for match grinding or for quality control. In any case, the measuring results are reported to the machine for correction or adaptation of the grinding process.

Parameters measured pre- or post-process

- Plain outer diameters
- Inner diameters
- Radial run-out
- Concentricity
- Interrupted outer diameters
- Length
- Roundness
- Conicity

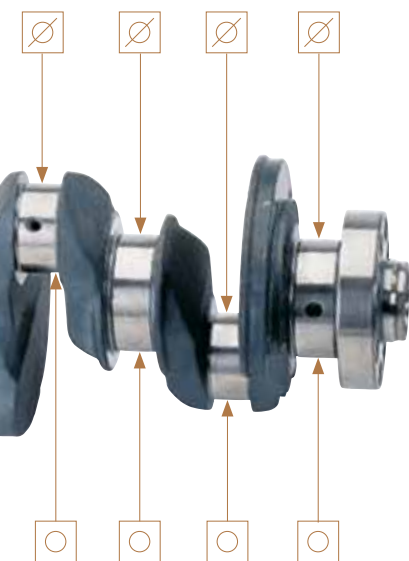
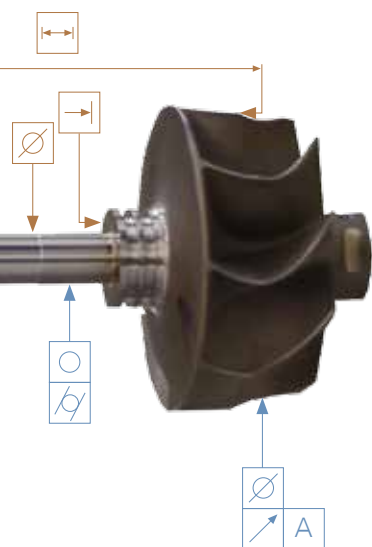
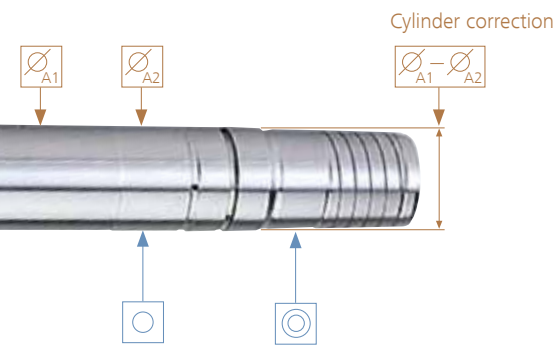

■ In-process

■ Pre-/Post-process



Get better measurements

... with innovative measuring systems

MOVOLINE solutions are the result of our decades of experience and extensive know-how of in-process metrology. They are the preferred system of choice for grinding machine manufacturers around the world.

With the development of the first in-process measuring system for grinding machines in the world and the very first digital gage heads, we have established new quality standards for in-process applications. Now and in future you can be sure that we deliver highly innovative and technologically advanced in-process measuring systems.

... with modern digital technology

Thanks to the field bus technology – unique in in-process applications – MOVOLINE solutions always deliver precise measuring results, even under difficult operating conditions. The measuring data is transferred digitally and therefore interference-free and independent of the cable length. Furthermore installation and maintenance efforts are reduced thanks to the reduced number of necessary cables for the in-process measuring components.

... for highest process reliability

MOVOLINE solutions offer highest precision and reliability for the control of grinding processes. They compensate process influences due to temperature fluctuations or wear of the grinding wheel and thus help making your machining processes more efficient, reduce cycle times and increase product quality.

Effective assurance of your product quality

Precise

- Consistent measuring accuracy
- High repeatability thanks to outstanding thermal and mechanical stability of the gage heads
- Highest process reliability even for smallest workpiece tolerances

Safe

- Interference-free data transfer thanks to field bus technology
- Mechanical crash protection
- Electric motor operated gage arm lifting

Reliable

- Long term stability of all measuring components
- Compact and protected design for use in production
- Low maintenance and wear-free components

Control cycle in-process measurement

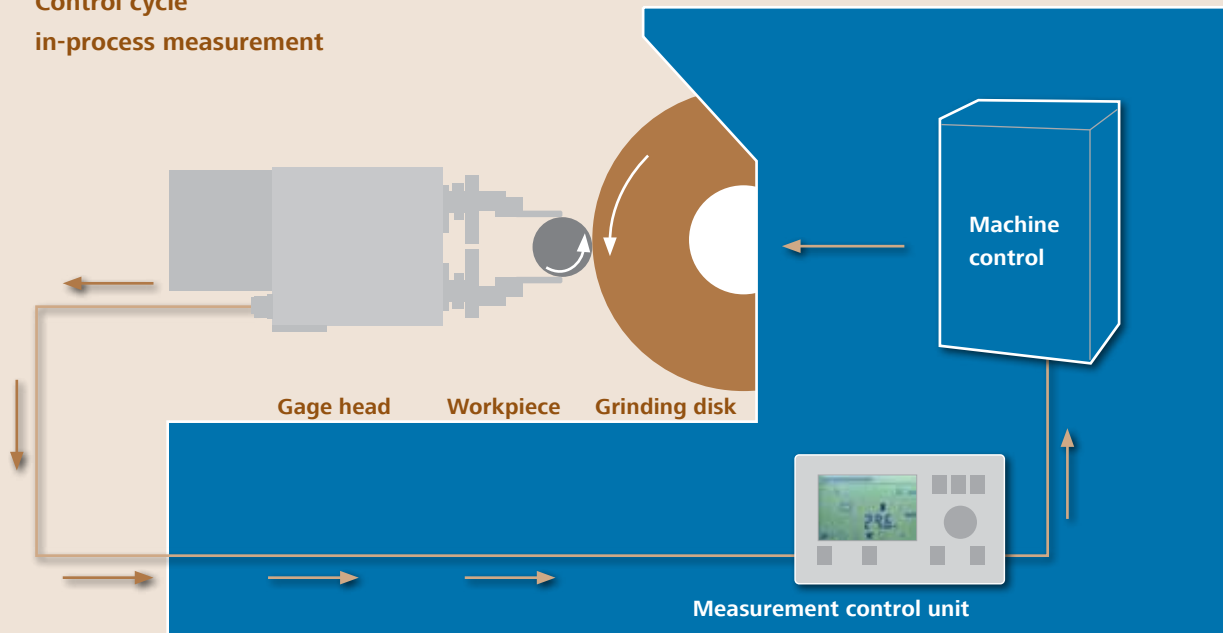

Flexible

- Gage heads with large measuring ranges
- From small batch series to large-scale production
- Parallel measurement of different parameters on one workpiece

Custom-designed

- Easily adaptable to various measuring tasks, workpieces and machines
- For in- as well as pre- and post-process applications

Easy to integrate

- Easy setting and installation of the measuring components
- Retrofitting of existing operating machines
- Control of all measuring functions via one single cable

Economic solution for series manufacturing



Measurement requirements

Measurement of length and diameter on a spindle with a cycle time of 35 seconds including charging and discharging.

Spindle diameter measurement with passive workpiece positioning. The admissible tolerance for a nominal diameter of 12 mm is 4 μ m.

MOVOLINE solution

- Positioning of the grinding wheel dependent on the workpiece face with a DP200 gage head for axial positioning
- Diameter measurement with a DM400 gage head for plain outer diameters
- Pneumatic slide as there is no hydraulics available in the machine
- Economic table unit ES124 for measurement control

Process reliability even for complex measuring tasks

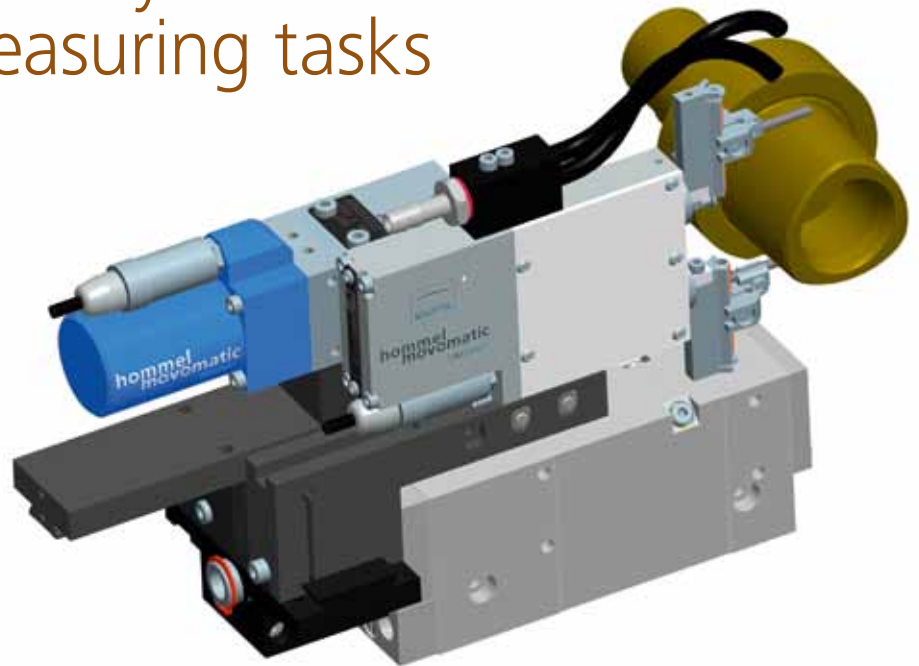
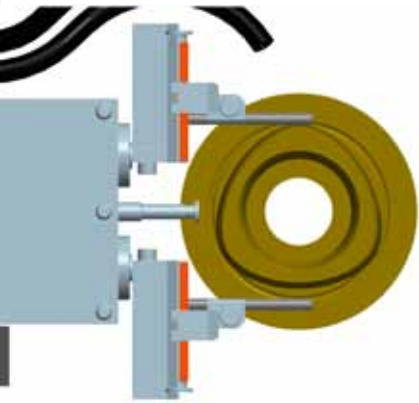

Measurement requirements

In-process measurement during grinding of a polygon workpiece holder according to ISO 26623-1:2008. For example, the nominal value of the workpiece holder diameter is 32-100 mm with a polygon diameter of 22-72 mm and a typical tolerance of 8 μm on the polygon diameter.

MOVOLINE solution

- Active positioning of the workpiece after clamping in the grinding machine with the touch trigger probe C250 (not shown)
- Length positioning with the DP200 gage head in order to identify the defined measurement position for determination of the diameter
- Measurement of the largest outer polygon diameter in reference to the face with a DM205 gage head for interrupted outer diameters
- ES400 measurement control unit with custom-designed software

Optimum protection



Crash protection DMprotect 200

The optional **crash protection** in form of a defined breaking point offers effective protection against damages of gage head, gage arms or workpiece in case of collision, thus preventing machine shutdown times.

Increased productivity thanks to optimized measuring methods

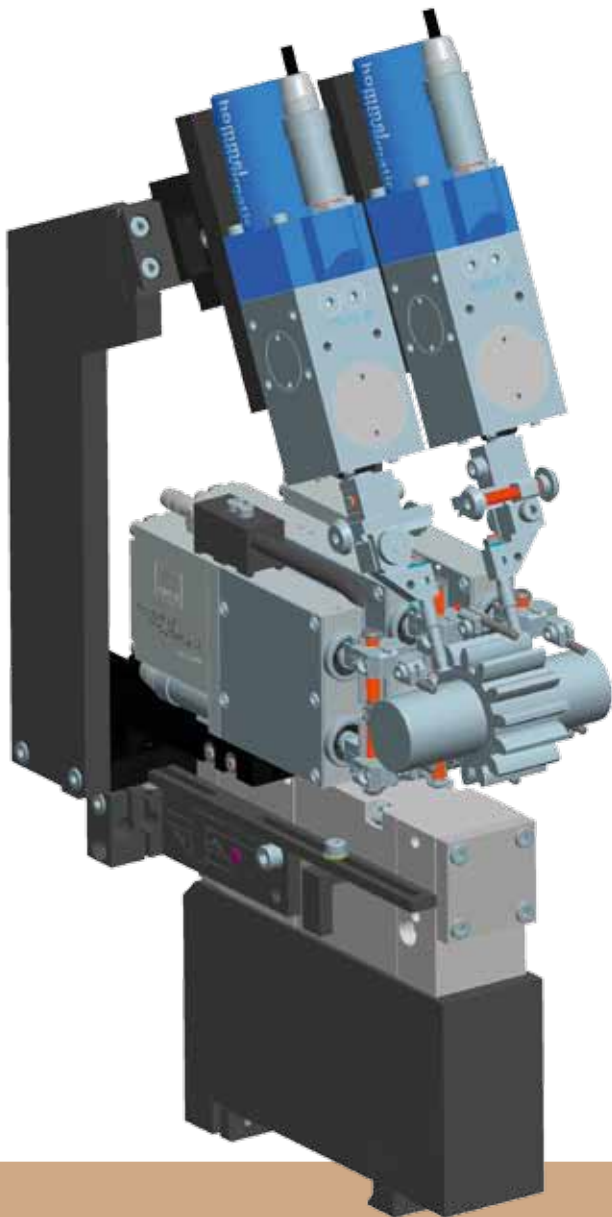

Measurement requirements

Measurement of a pump gear with two diameters on the bearing surfaces and one diameter on the gear pinion as well as determination of the gear pinion width with a length measurement.

The admissible tolerance for diameters is typically $6\ \mu\text{m}$, for length $4\ \mu\text{m}$.

MOVOLINE solution

- Measurement of plain outer diameters on the bearing surfaces with two DM200 gage heads
- Measurement of the gear pinion with a DM205 gage head for interrupted outer diameters
- Length measurement of the gear pinion with two gage heads DP200 for passive axial positioning
- Integrated measurement control unit ESI140 for operation and visualization of the measurement process via the machine user interface

Smooth processes



Gage arm lifting

The **gage arm lifting** offers safe approach of the measurement position even with interrupted surfaces. Thanks to the electric motor operation, the gage arm lifting can be controlled via the existing cable of the gage head – further connections (e.g. pneumatic) are not necessary.

Fast adjustment to new workpieces for small batch series



Measurement requirements

In order to optimize the flexible production process for small batch series, different diameters from 18 to 44 mm have to be measured with one gage head and low setup times. The tolerance allowed is 6 μm .

MOVOLINE solution

- Two DU200 gage heads with rotary knob for quick adjustment to new diameters, large measuring range as well as integrated crash protection
- Hydraulic slide, mounted on the machine table
- Measurement control as table unit or rack-mounted depending on the requirements

Easy and quick adjustment



Quick adjustment of the DU200 gage head

With the **rotary knob** you loosen the gage arms of the DU200 gage head in order to adjust them to new diameters. An additional mechanical zero adjustment is not necessary. This guarantees quick changes of workpieces, especially for small batch series.

Highest accuracy and large measuring ranges for diameters

Gage heads for plain outer diameters

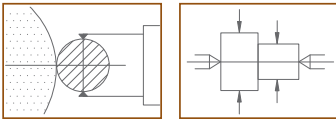

Workpiece diameter
 Measuring range
 Repeatability error 6s
 Gage arm lifting
 Damping
 Crash protection



DM200
 1-60* mm
 ±250 µm
 < 0.1 µm
 optional
 optional
 optional



DM400
 5-160* mm
 ±500 µm
 < 0.2 µm
 optional
 optional
 optional

Gage heads for plain and interrupted outer diameters

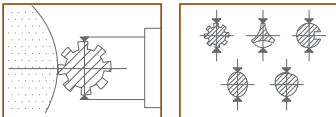

Workpiece diameter
 Measuring range
 Repeatability error 6s
 Gage arm lifting
 Damping
 Crash protection



DM205
 1-60* mm
 ±500 µm
 < 0.1 µm
 yes
 yes
 optional



DM405
 5-80* mm
 ±500 µm
 < 0.2 µm
 yes
 yes
 optional



DU200
 4-80* mm
 ±500 µm
 < 0.5 µm
 yes
 yes
 yes

Custom-designed

We deliver accessories that are adapted to your measuring tasks, such as custom-designed gage arms and gage tips – also for inner diameters.

* Larger measuring ranges available on request.

Positioning gage heads for reliable and precise measurements

Gage head for passive axial positioning and length measurements

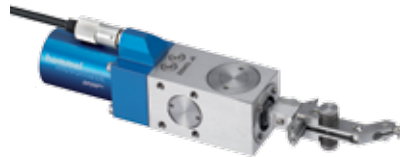
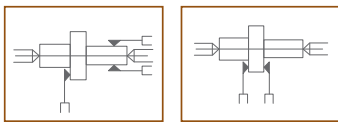

Measuring range
 Repeatability error 6s
 Gage arm lifting
 Damping
 Crash protection
 Reversion of probing direction

DP200

$\pm 2000 \mu\text{m}$
 $< 0.3 \mu\text{m}$
 $\pm 2 \text{ mm}$
 yes
 optional
 yes

Touch trigger probe for active positioning

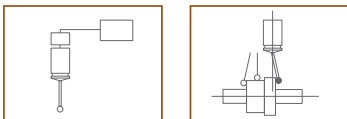

Sense directions
 Repeatability error 2s

C250

$\pm X, \pm Y$ and $-Z$
 $\pm 1 \mu\text{m}$

Optimal adaptation to your measuring task

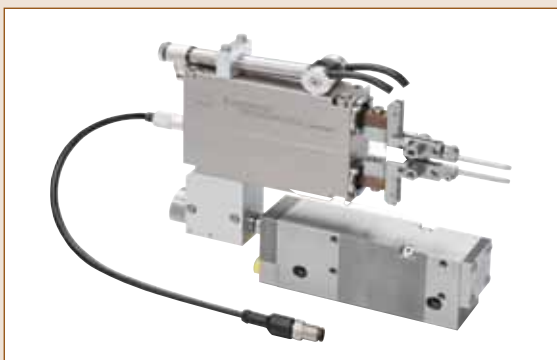

Gage head DM400 with slide

For the movement of the gage head to and from the workpiece, high-precision slides are used, available either with pneumatic or hydraulic technology, depending on the machine requirements:

	Connection/supply	Stroke (in mm)
DR260	hydraulic	5-100
DR275	hydraulic	110-160
RP70	pneumatic	70
RP100	pneumatic	100

Measurement control units for variable requirements

MOVOLINE measurement control units offer a wide range of possible applications, in in-process as well as pre- or post-process measurements. The choice of the most suitable device depends on the measuring requirements and the machine.



ES124: the economy model for easy and reliable measurements

- 2 connectable gage heads
- For diameter and length measurements
- Outputs:
 - 3-5 Relays
 - BCD signal
 - Optocoupler
 - RS232
- Models: table unit, rack-mounted ½ 19" or remote panel



ES400: multifunctional control of demanding measurements

- 4 connectable gage heads, extensible to 8
- For standard diameter and length measurements as well as custom-designed measuring tasks, for example cylinder correction
- Outputs:
 - Relays
 - BCD signal
 - Profibus
 - Optocoupler
 - RS232
- Models: table unit, rack-mounted 19" or remote panel



ESZ400: modern, integrated solution for highest demands

- 2 connectable gage heads, extensible to 16
- For standard diameter and length measurements as well as custom-designed measuring tasks, for example cylinder correction
- Outputs:
 - Relays
 - BCD signal
 - Profibus
 - Optocoupler
 - RS232
- Model: rack-mounted ½ 19"

Integrated solution – operation via the machine control display

With the ESi140 and ESi440 measurement control units and the Windows based INPROVIS software, operation and display of all measurement control functions are carried out directly via the graphical user interface of the grinding machine control – without additional displays or connecting cables.

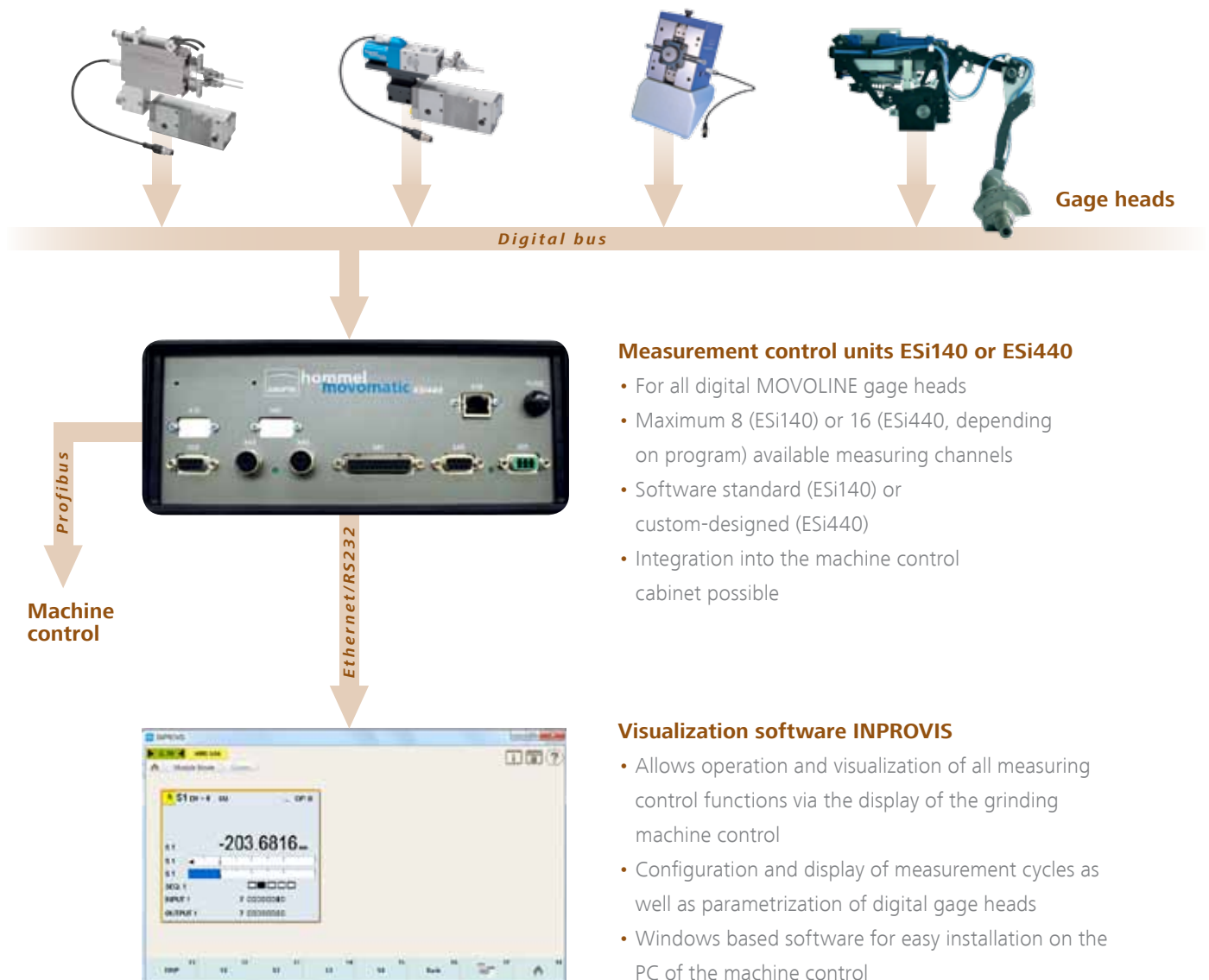



Diameter and roundness measurement of crank shafts in pendulum stroke grinding machines

Developed especially for use in modern pendulum stroke grinding machines, the DF500 and DF700 measuring systems enable automatic monitoring of crank shaft diameters during the grinding process at full machining speed.

- Measurement of main and pin bearings
- Simple retooling for crank shafts with different dimensions
- High resolution for all diameters
- Interference-free, digital measured value transmission
- Efficient measurement control, operator interface can be integrated into the PC/CNC machine control
- Solid mechanical design for high measuring accuracy and collision-free processes
- Used universally thanks to interchangeable measuring prisms with wide diameter ranges

Measuring systems for diameters and roundness

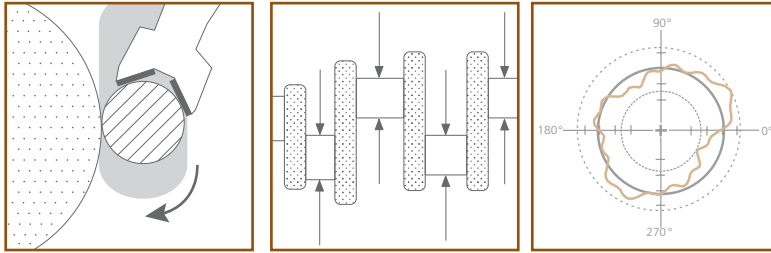

	DF500	DF700
Diameter measurement		
Workpiece diameter	24-90 mm	48-140 mm
Stroke	≤ 120 mm	≤ 340 mm
Measurement speed	≤ 80 rpm	≤ 80 or 65 rpm
Resolution	0.1 μm	0.1 μm
Roundness measurement		
Evaluation points/revolution	3600	3600
Resolution	0.1 μm	0.1 μm
Measurement speed	≤ 60 rpm	≤ 60 rpm
Evaluation method	LSCI	LSCI

Monitoring and correction of roundness (optional)

- Detection and correction of systematic errors in roundness during machine setup
- Measurement of roundness at the end of the machining process using automatic correction value control
- Significant increase of the accuracy of the machine tool and the produced workpieces
- 100 % control directly in the production process



Automatic alignment of the measuring system

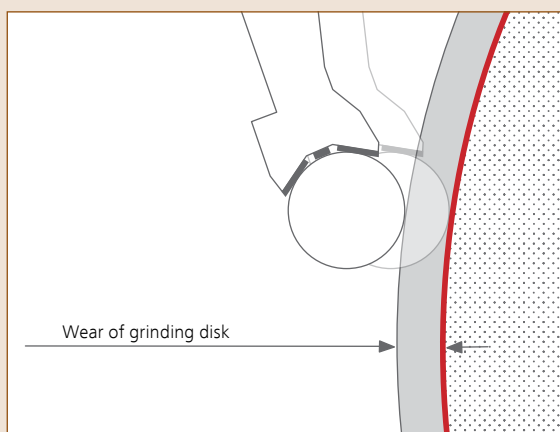

Automatic alignment of the gage head

Wear of the grinding disk may considerably influence the machining quality and should therefore be monitored.

The DF500 and DF700 measuring systems are optionally equipped with a **motorized automatic alignment** in order to re-position the gage head according to the wear of the grinding disk. This ensures that the gage head is always in the optimum measurement position, thus eliminating any possibility of collision of the gage head with the grinding disk.

Efficient quality assurance in all process steps

MOVOLINE gage heads and measurement control units offer optimum solutions whenever automatic correction value control is needed – in every process step.

In-process measurements allow for the continuous measurement of workpiece dimensions during grinding in the working space of the grinding machine, whereas pre- or post-process measurements take place before or after grinding.

Pre-process measurements are executed before the grinding operation in order to control the latter in accordance with the measuring results, for example for match grinding.

Post-process measurements are carried out immediately after machining, for quality control and subsequent readjustment of the machine or for statistical process control (SPC).

In every case a fast transmission of the correction value to the grinding machine assures efficient and economic production of workpieces with finest tolerances.

You can be sure that you will always get the best suitable measurement configuration. Thanks to our extensive portfolio of services and our decades of experience, we are able to offer not only tactile but also pneumatic solutions for pre- or post-process measurements.

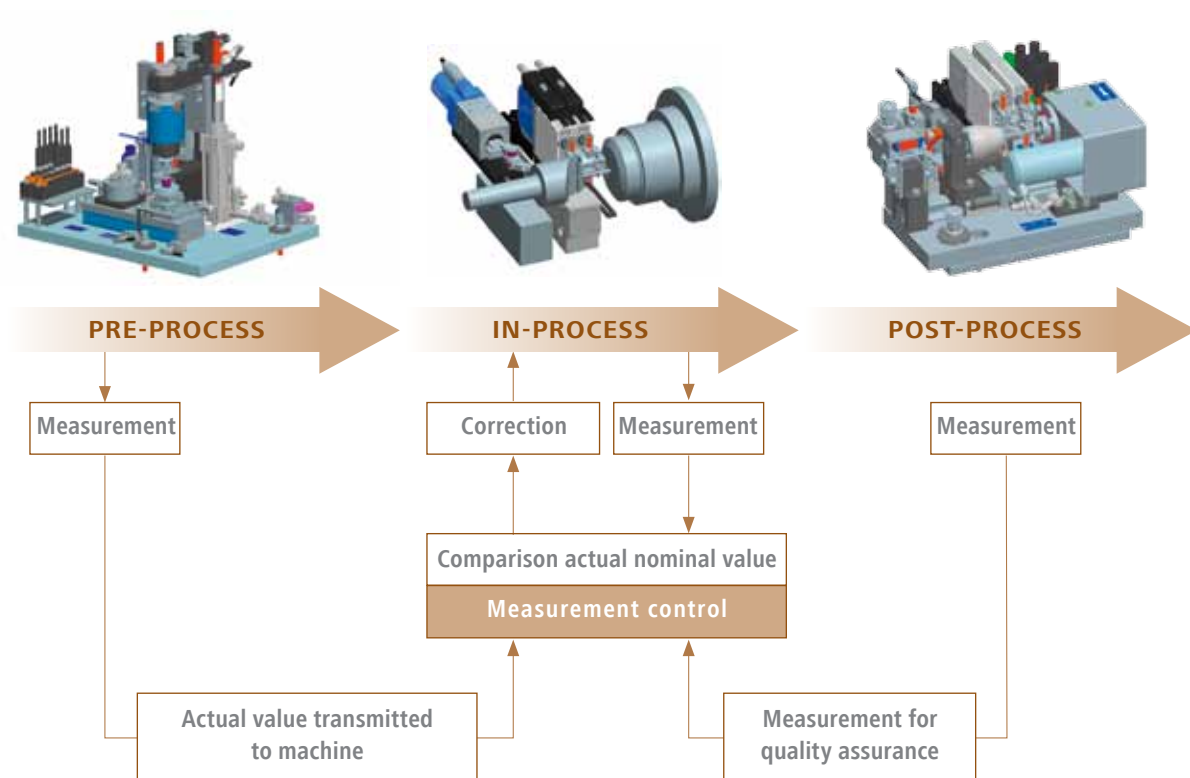

Combined pre- and in-process measurements: match grinding

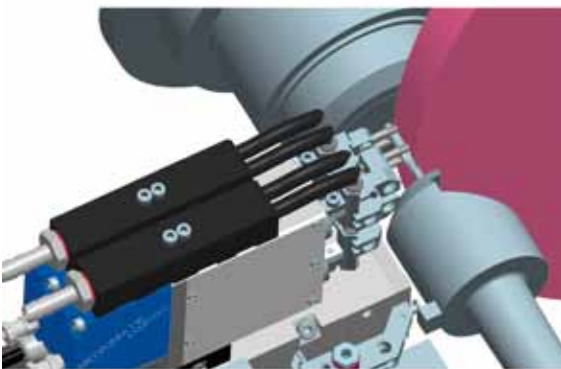
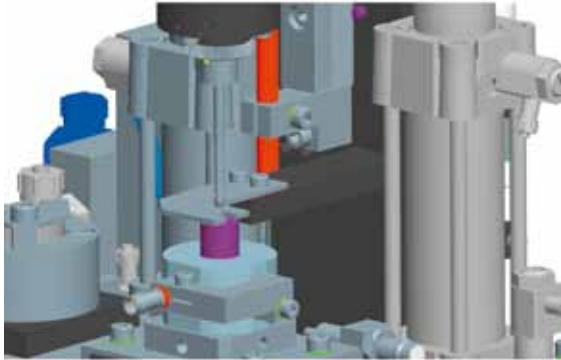

Measurement requirements

Match grinding of injector components: measurement of inner diameters of nozzle body and of outer diameters of nozzle needle with an admissible tolerance of 2 μm .

MOVOLINE solution

Pre-process:

- Pneumatic measurement of the inner diameter of the nozzle body on two levels with Hommel-Etamic air tooling
- Tolerance range for inner diameter: 5 μm

In-process

- Determination of the corresponding outer diameter with two DM200 gage heads
- The nozzle needle is grinded and controlled in-process according to the transmitted values from the pre-process measurement

Measurement control unit pre- and in-process

- ES400 for measurement control

According to the requirements: pneumatic or tactile pre-process measurements

Measurements in deep bores and on different levels are measured with pneumatic air tooling with typical measuring ranges from ± 20 to ± 60 . Tactile gage heads have a larger measuring range and offer economic solutions when measuring inner diameters on one level and whenever the roundness has to be determined.

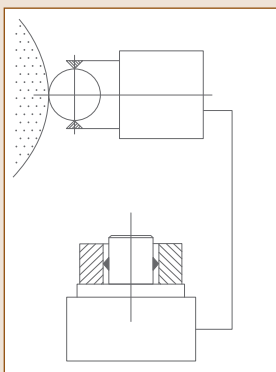

DI200

Tactile gage head for inner diameters and match grinding: DI200

Workpiece inner diameter	4-100 mm
Measuring range	$\pm 100 \mu\text{m}$
Repeatability error 6s	< 0.2 μm
Measuring force	0.8 - 1.4 N

Immediate control of the process step

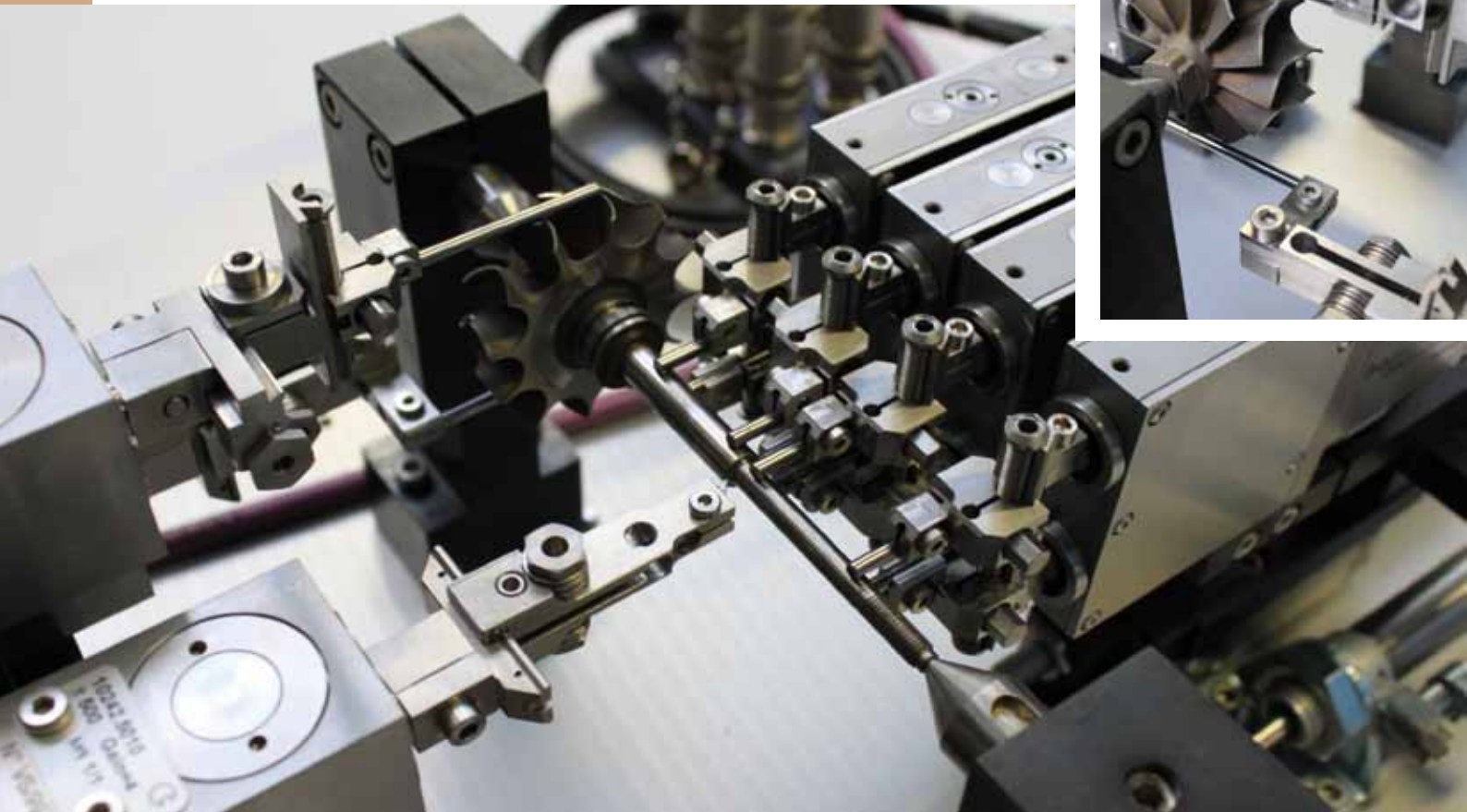

Measurement requirements

Post-process measurement of turbo-chargers in a loader operated measuring station with a cycle time of 8.5 seconds. The admissible tolerance of for example two outer diameters is 3 μm , the one of the length is 50 μm .

MOVOLINE solution

- Four DM200 gage heads for outer diameters
- Creation of a reference axis for measurement of diameter and axial run-out with a tolerance of 30 μm on the wheel
- Length measurement with two DP200 gage heads
- Gage heads with pneumatic slide, as commonly used with loader operated measuring stations
- Optional crash protection DMprotect 200 in order to reduce down times due to damages
- ESZ400 measurement control unit with custom-designed software

Excellent industrial metrology

WAVELINE

Roughness and Contour Metrology

Mobile roughness measuring devices and manual or automated surface measuring systems for measuring roughness, contour, topography and twist, combined systems for roughness and contour, visual surface inspection for cylinder bores as well as customized solutions.

FORMLINE

Form Metrology

Manual and CNG-controlled systems for measuring form, position and twist (device-dependent); combined form and roughness measuring systems, systems for form measurement in cylinder bores, spindle measuring machines, crank shaft and cam shaft measuring machines and workpiece-specific solutions.

OPTICLINE

Optical Shaft Metrology

Optical measuring systems for determining dimensions, form, position and geometric elements on shaft-shaped workpieces. Use as a SPC measuring station, offline or automated stations in concatenated applications and as customized solutions for workpiece-specific requirements.

GAGELINE

Dimensional Metrology

Pre-process/in-process/post-process measuring systems with tactile, pneumatic or optical measuring principles, manual and automatic measuring devices, final inspection measuring machines, customized inline measuring systems and optical surface inspection.

MOVOLINE

In-Process Metrology

Digital gage heads, control devices and accessories for tactile in-process measurement of diameter, position and length in tooling machines with an aim to controlling the machining process.

SERVICELINE

Services Worldwide

Services relating to metrology such as consultation and training, order measurements and relocation services, production monitoring, (remote) maintenance and calibration, repairs and spare parts/replacement service, measuring program development and measurement process optimization.



Head Office
JENOPTIK Industrial Metrology Germany GmbH

Alte Tuttlinger Straße 20
78056 VS-Schwenningen
Germany
Phone +49 7720 602-0

Close to you. Group companies in:

Germany	USA	China
France	Mexico	Singapore
Switzerland	Brazil	South Korea
Spain		India
Czech Republic		

Affiliates and representation worldwide:
www.jenoptik.com/metrology

Please contact us:
info.im@jenoptik.com