



0800 0266 383
cleanair.co.uk

BENSON

PV

High Efficiency Cabinet Heaters





PV

High Efficiency Cabinet Heaters

The Benson Heating PV range of tubular vertical gas fired cabinet heaters are suitable for a wide variety of commercial and industrial applications.

Suitable for free blowing applications PVN models are supplied complete with adjustable discharge nozzles. For ducted air installations PVD units are supplied complete with a duct outlet spigot.

Optional Equipment

A range of options are available. These include:

- > Stainless steel heat exchanger
- > High/low burner
- > Modulation burner control
- > Side inlet filters
- > Up rated fan motor for up to 200Pa on units 72 to 145

Model Range

The PV cabinets are available in six heat outputs from 29kW to 144kW. Standard units are suitable for natural gas (G20) and units may also be specified as an option to operate on Propane (G31).

Applications

- > Factories
- > Horticulture
- > Greenhouses
- > Showrooms
- > Warehouses
- > Workshops

Specification

Heat Exchanger and Burner

Four pass aluminised steel heat exchanger is weld free to ensure enhanced life expectancy. Stainless steel heat exchanger tubes are available as an option.

Units are fitted with low noise burner complete with electronic ignition, safety flame monitoring and overheat protection.

The heat exchanger and burner combination provides high thermal efficiencies in excess of 91% (net CV).

Air Distribution

Double inlet centrifugal fans circulate large air volumes evenly across the heat exchanger to give low surface temperatures and optimised heat transfer.

Free blowing units are supplied complete with aerodynamic discharge nozzles for extended throws. Nozzles are complete with horizontal louvres and may be rotated through 360° to ensure good air distribution.

Electric Motors

All electric motors comply with EC motor directive 2005/32/EC

Cabinets

Manufactured from electro zinc coated steel the cabinet is finished in a stove hardened epoxy powder paint finish to provide a robust and durable case. For safety and aesthetics all controls are fully enclosed behind a full width hinged access door fitted to the front of the heater.

Controls

Units are supplied complete with SmartCom, an integral fully optimised electronic time and temperature control system with password protection facility.

Installation

Units should be installed on a flat noncombustible base capable of supporting the unit weight and ensuring that the recommended clearances for correct airflows and service access are observed.

Consideration must also be given to the route and length of the flue, and if required the ducted combustion air inlet.

Versatile Flue Installation

Heaters are fitted with an integral flue fan and are CE certified to be used as either balanced flue room sealed or fan assisted appliances.

The balanced flue terminals provide both the flue outlet and combustion air inlet.

Where heaters are installed without connection to combustion air pipe work, adequate provision must be made for combustion air ventilation.

The integral flue fan permits both roof and wall terminations and allows the heater to be sited several metres away from the flue exit.

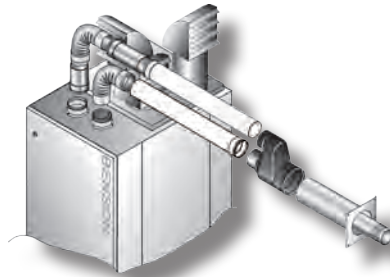

Balanced flue wall outlet (type C12) eliminates expensive roof opening and flashing



Balanced flue roof outlet (type C32)

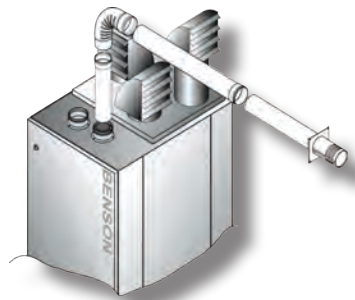

Fan assisted flue through wall (type B22) without combustion air pipe eliminates expensive roof opening and flashing

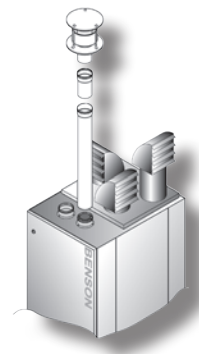

Fan assisted flue through roof (type B22) without combustion air pipe

Technical Data		Model Ref					
		PV30	PV50	PV72	PV95	PV120	PV145
Nominal heat output	kW	29	49	72	96	120	144
Airflow	m ³ /h	2880	3780	5400	8280	10980	13176
Temperature rise	K	30	37	39	34	32	32
Throw ¹ (PVN)	m	18	19	19	26	29	26
Static pressure (PVD Standard)	Pa	80	110	100	130	150	150
200 ESP upgrade		-	-	200	200	200	200
Gas Consumption							
Natural gas G20	m ³ /h	3.38	5.63	8.33	11.12	13.87	16.63
Propane G31	m ³ /h	1.30	2.16	3.21	4.28	5.34	6.41
Gas connection ²	Rc	½"	½"	¾"	¾"	¾"	¾"
Minimum Gas Inlet Pressure							
Natural gas G20	mbar	17.5	17.5	17.5	17.5	17.5	17.5
Propane G31	mbar	37.0	37.0	37.0	37.0	37.0	37.0
Electrics							
Supply	V/ph hz	230/1/50	230/1/50	230/1/50	415/3/50	415/3/50	415/3/50
Optional	V/ph/hz	n/a	n/a	n/a	230/1/50	230/1/50	n/a
FLC (std motor)	amp	3.2	3.2	7.2	3.6	5.2	6.5
Flue diameter	mmø	100	100	130	130	130	130
Combustion air diameter	mmø	100	100	130	130	130	130
Maximum horizontal run ⁴	m	6.0	6.0	8.0	8.0	8.0	8.0
Maximum vertical run ⁴	m	10.0	10.0	10.0	10.0	10.0	10.0
Nozzles (PVN)	no.	2	2	3	3	3	4
Noise level ³	dB(A)	63	64	72	74	74	76
Net weight (PVN)	kg	192	202	330	380	440	460

1. Throw is dependent on building height, room temperature and nozzle settings.
2. Gas lines must be adequately sized and reduced at appliance as required.
3. Noise levels measured at 3 metres from appliance. Noise levels at 5 metres available on request.
4. Reduce distance by 1.0m for every 90°degree elbow & 0.8m for 45°degree elbow.

DIMENSIONS

		Model Ref					
		PV30	PV50	PV72	PV95	PV120	PV145
Unit height	A	1650	1650	1830	1830	1960	1960
Unit width	B	700	700	840	840	840	840
Unit depth	C	1080	1080	1395	1395	1625	1625
Flue diameter	D	100	100	130	130	130	130
	E	189	189	255	255	255	260
	F	263	263	311	311	283	287
Overall height	G	1725	1725	1890	1890	2020	2020
Duct outlet PVD	H	570	570	769	769	769	769
Duct outlet PVD	J	570	570	984	984	1214	1214
	K	103	103	169	169	95	95
	L	967	840	963	894	934	894
	M	280	280	314	314	355	355
Nozzle outlet PVN	N	285	324	352	352	410	410
Nozzle outlet PVN	P	n/a	n/a	677	677	815	815
Installation clearance - front		700	700	840	840	840	840
Installation clearance - side		150	150	150	150	150	150
Installation clearance - rear		400	400	400	400	400	400

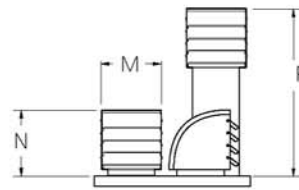
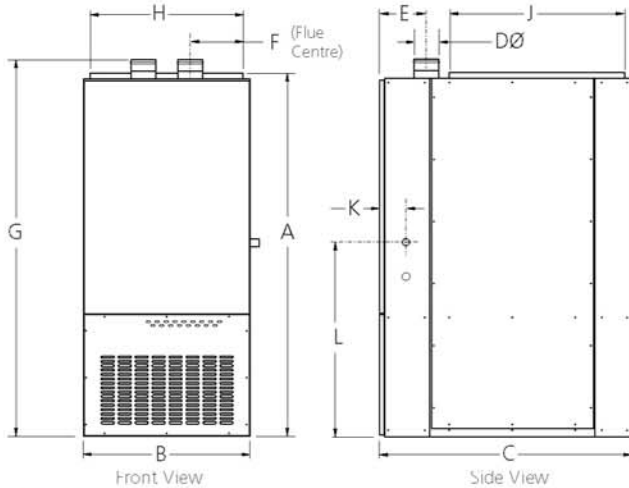

Units with more than 2 nozzles are supplied as standard with height extensions for rear nozzles. Standard nozzles may be specified for height sensitive applications or installations where cabinets are located centrally within the space.

Return Air Dimensions

		Model Ref					
		PV30	PV50	PV72	PV95	PV120	PV145
Side inlet spigot	A	348	348	560	560	560	560
	B	522	522	850	850	1030	1030
Rear inlet spigot	C	468	468	560	560	560	560
	D	650	650	677	677	677	677
Inlet filter assembly	E	420	420	645	645	720	720
	F	660	660	990	990	1245	1245
	G	300	300	300	300	450	450

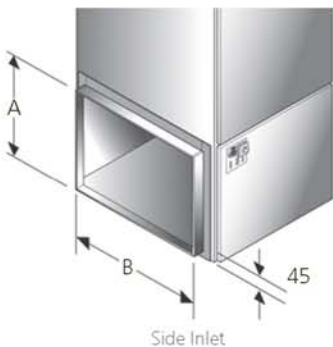

Side Inlet

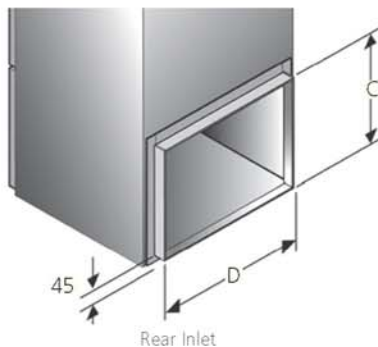

Rear Inlet

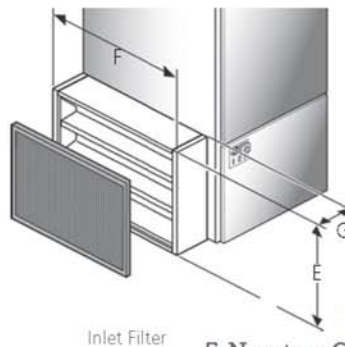

Inlet Filter

Filter assemblies can be side mounted only. Filter assemblies must be specified for either left hand or right hand side.

CLEAN AIR GROUP

5 Newton Close, Drayton Fields
Daventry, Northants NN11 8RR

Tel: 01327 301 383
Fax: 01327 301 384

info@cleanair.co.uk
www.cleanair.co.uk



creating a better work environment

Clean Air Group is a trading style of
Clean Air Installations Limited Registered in England No.3915686
Clean Air Facilities Limited Registered in England No.3965661

Document reference number - GB/EN/004/0913