

## OPERATORS MANUAL

---

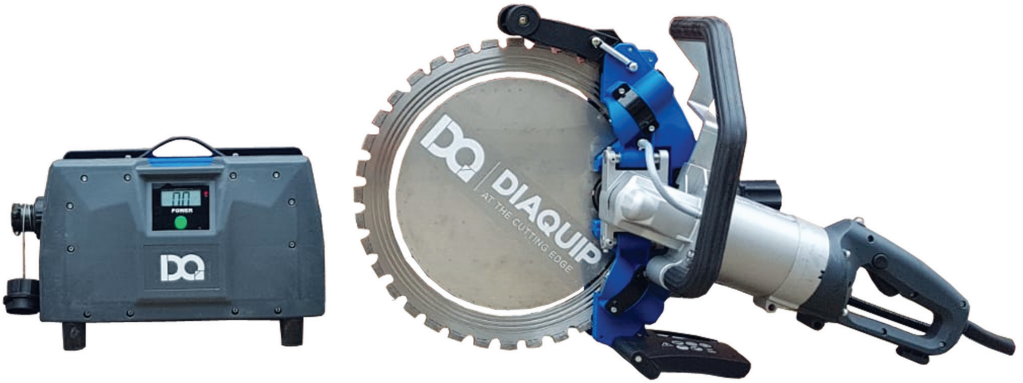

---

## QRS-400 HIGH-FREQUENCY RING SAW & QPP-800 POWER PACK

# TECHNICAL DATA

## TECHNICAL DATA

### High Frequency Ring Saw

Power	1Ø~ 200-240V 5500W (32A), 3600W (16A) 3Ø~220-240V 5500W 3Ø~380-480V 6500W
No Load Rpm	2500/min
Linear Speed	53m/s
Blade Diameter	400mm (15-3/4")
Max. Cutting Depth	300mm (11-13/16")
Protection Class	IP55
Dimensions (L x W x H)	830mm x 240mm x 460mm
Weight	12.8kg ( 27.5 Lbs)

### Power Converter

Power Input (maximum)	1Ø~ 200-240V 32A 3Ø~220-240V 25A 3Ø~380-480V 16A
Min. Water Flow (25°C)	3.5 L/min (1 gpm)
Max. Water Pressure	7 bar (100 psi)
Dimensions (L x W x H)	460mm x 220mm x 260mm
Weight	7.1kg (15.6 Lbs)



1. Main Handle
2. Trigger Switch
3. Release Button
4. Load Warning Lamp
5. Side Handle
6. Upper Splash Guard
7. Water Plate
8. Ringsaw Blade (3-groove type)
9. Guide Wheel
10. Lower Splash Guard
11. Motor
12. Water Feed Valve
13. Drive Tensioner Knob
14. Guide Tensioner Knobs
15. Thumb Knob
16. Cover Plate
17. Drive Wheel
18. Arbor Bolt
19. Motor Coupling Socket
20. Power Converter
21. Water Supply Inlet / Outlet
22. Power Button
23. LCD Display

# GENERAL SAFETY INSTRUCTIONS



**WARNING!** Read all safety warnings and all instructions. Failure to follow the warnings and instructions may result in electric shock, fire and/or serious injury.

**ORIGINAL INSTRUCTIONS:** For your personal safety, read and understand before using. Save these instructions for future reference

**Warning:** On tools equipped with over load protection, when motor has been cut off due to over load, always switch on machine with no load for at least 3 minutes to reduce temperature before returning to operation to avoid burn out of the motor.

**Save all warnings and instructions for future reference.**

The term “power tool” in the warnings refers to your mains-operated (corded) power tool or battery-operated (cordless) power tool.



## General Power Tool Safety Warnings - Work Area Safety

- a. **Keep work area clean and well lit.** Cluttered and dark areas invite accidents.
- b. **Do not operate power tools in explosive atmospheres, such as in the presence of flammable liquids, gases or dust.** Power tools create sparks which may ignite the dust or fumes.
- c. **Keep children and bystanders away while operating a power tool.** Distractions can cause you to lose control.
- d. **Never leave the electric power tool unattended.** Only leave the machine when the tool in use has come to a complete standstill.



## General Power Tool Safety Warnings - Electrical Safety

- a. **Power tool plugs must match the outlet. Never modify the plug in any way. Do not use any adapter plugs with earthed (grounded) power tools.** Unmodified plugs and matching outlets will reduce risk of electric shock.
- b. **Avoid body contact with earthed or grounded surfaces, such as pipes, radiators, ranges and refrigerators.** There is an increased risk of electric shock if your body is earthed or grounded.
- c. **Do not expose power tools to rain or wet conditions.** Water entering a power tool increase the risk of electric shock.



# GENERAL SAFETY INSTRUCTIONS



## General Power Tool Safety Warnings - Electrical Safety (continued)

- d. **Do not abuse the cord. Never use the cord for carrying, pulling or unplugging the power tool. Keep cord away from heat, oil, sharp edges or moving parts.** Damaged or entangled cords increase the risk of electric shock.
- e. **When operating a power tool outdoors, use an extension cord suitable for outdoor use.** Use of a cord suitable for outdoor use reduces the risk of electric shock.
- f. **If operating a power tool in a damp location is unavoidable, use a residual current device (RCD) protected supply.** Use of an RCD reduces the risk of electric shock.



## General Power Tool Safety Warnings - Personal Safety

- a. **Stay alert, watch what you are doing and use common sense when operating a power tool. Do not use a power tool while you are tired or under the influence of drugs, alcohol or medication.** A moment of inattention while operating power tools may result in serious personal injury.
- b. **Use personal protective equipment. Always wear eye protection.** Protective equipment such as dust mask, non-skid safety shoes, hard hat, or hearing protection used for appropriate conditions will reduce personal injuries.
- c. **Prevent unintentional starting. Ensure the switch is in the off-position before connecting to power source and/or battery pack, picking up or carrying the tool.** Carrying power tools with your finger on the switch or energising power tools that have the switch on invites accidents.
- d. **Remove any adjusting key or wrench before turning the power tool on.** A wrench or a key left attached to a rotating part of the power tool may result in personal injury.
- e. **Do not overreach. Keep proper footing and balance at all times.** This enables better control of the power tool in unexpected situations.
- f. **Dress properly. Do not wear loose clothing or jewellery. Keep your hair and clothing away from moving parts.** Loose clothes, jewellery or long hair can be caught in moving parts.
- g. **If devices are provided for the connection of dust extraction and collection facilities, ensure these are connected and properly used.** Use of dust collection can reduce dust related hazards.
- h. **Do not let familiarity gained from frequent use of tools allow you to become complacent and ignore, tool safety principles.** A careless action can cause severe injury within a fraction of a second.

# GENERAL SAFETY INSTRUCTIONS



## General Power Tool Safety Warnings - Power Tool Use And Care

- a. **Do not force the power tool. Use the correct power tool for your application.**  
The correct power tool will do the job better and safer at the rate for which it was designed.
- b. **Do not use the power tool if the switch does not turn it on and off.** Any power tool that cannot be controlled with the switch is dangerous and must be repaired.
- c. **Disconnect the plug from the power source and/or battery pack from the power tool before making any adjustments, changing accessories, or storing power tools.** Such preventive safety measures reduce the risk of starting the power tool accidentally.
- d. **Store idle power tools out of the reach of children and do not allow persons unfamiliar with the power tool or these instructions to operate the power tool.**  
Power tools are dangerous in the hands of untrained users.
- e. **Maintain power tools. Check for misalignment or binding of moving parts, breakage of parts and any other condition that may affect the power tool's operation. If damaged, have the power tool repaired before use.** Many accidents are caused by poorly maintained power tools.
- f. **Keep cutting tools sharp and clean.** Properly maintained cutting tools with sharp cutting edges are less likely to bind and are easier to control.
- g. **Use the power tool, accessories and tool bits etc. in accordance with these instructions taking into account the working conditions and the work to be performed.** Use of the power tool for operations different from those intended could result in a hazardous situation.
- h. **Keep handles dry, clean and free of oil and grease.** Slippery handles do not allow for safe handling and control of the tool in unexpected situations.



# GENERAL SAFETY INSTRUCTIONS



## General Power Tool Safety Warnings - Service

- a. **Have your power tool serviced by a qualified repair person using only identical replacement parts.** This will ensure that the safety of the power tool is maintained.
- b. **Only use original parts for repair and maintenance.** The use of incompatible accessories or spare parts can result in electric shocks or other injuries.

### Symbols used in this manual

V.....Volts

A.....Amperes

Hz.....Hertz

W.....Watt

~.....Alternating current

$n_0$ ..... Rated speed

$\text{min}^{-1}$ .....Revolutions or reciprocation per minute

1Ø .....Single Phase Current

3Ø .....Three Phase Current



.....Protective earth



.....Warning of general danger



.....Read these instructions



.....Always wear eye protection



.....Always wear a dust mask.



.....Always wear hearing protection



.....Always use with water cooling



.....Wear safety-approved hard hat



.....DANGER! Keep hands away from cutting area and the blade.



Do not dispose of electric tools, accessories and packaging together with household waste material

# SAFETY INSTRUCTIONS FOR CUTTING-OFF OPERATIONS



## Cut-off machine safety warnings

- a. **The guard provided with the tool must be securely attached to the power tool and positioned for maximum safety, so the least amount of wheel is exposed towards the operator. Position yourself and bystanders away from the plane of the rotating wheel.** The guard helps to protect operator from broken wheel fragments and accidental contact with wheel.
- b. **Use only diamond cut-off wheels for your power tool.** Just because an accessory can be attached to your power tool, it does not assure safe operation.
- c. **The rated speed of the accessory must be at least equal to the maximum speed marked on the power tool.** Accessories running faster than their rated speed can break and fly apart.
- d. **Wheels must be used only for recommended applications. For example: do not grind with the side of cut-off wheel.** Abrasive cut-off wheels are intended for peripheral grinding, side forces applied to these wheels may cause them to shatter.
- e. **Always use undamaged wheel flanges that are of correct diameter for your selected wheel.** Proper wheel flanges support the wheel thus reducing the possibility of wheel breakage.
- f. **Do not use worn down reinforced wheels from larger power tools.** Wheels intended for larger power tools are not suitable for the higher speed of a smaller tool and may burst.
- g. **The outside diameter and the thickness of your accessory must be within the capacity rating of your power tool.** Incorrectly sized accessories cannot be adequately guarded or controlled.
- h. **The arbour size of wheels and flanges must properly fit the spindle of the power tool.** Wheels and flanges with arbour holes that do not match the mounting hardware of the power tool will run out of balance, vibrate excessively and may cause loss of control.
- i. **Do not use damaged wheels. Before each use, inspect the wheels for chips and cracks. If power tool or wheel is dropped, inspect for damage or install an undamaged wheel. After inspecting and installing the wheel, position yourself and bystanders away from the plane of the rotating wheel and run the power tool at maximum no load speed for one minute.** Damaged wheels will normally break apart during this test time.



# SAFETY INSTRUCTIONS FOR CUTTING-OFF OPERATIONS



## Cut-off machine safety warnings (continued)

- j. **Wear personal protective equipment.** Depending on application, use face shield, safety goggles or safety glasses. As appropriate, wear dust mask, hearing protectors, gloves and shop apron capable of stopping small abrasive or workpiece fragments. The eye protection must be capable of stopping flying debris generated by various operations. The dust mask or respirator must be capable of filtrating particles generated by your operation. Prolonged exposure to high intensity noise may cause hearing loss.
- k. **Keep bystanders a safe distance away from work area. Anyone entering the work area must wear personal protective equipment.** Fragments of workpiece or of a broken accessory may fly away and cause injury beyond immediate area of operation.
- l. **Hold the power tool by insulated gripping surfaces only, when performing an operation where the cutting accessory may contact hidden wiring or its own cord.** Cutting accessory contacting a “live” wire may make exposed metal parts of the power tool “live” and could give the operator an electric shock.
- m. **Position the cord clear of the spinning accessory.** If you lose control, the cord may be cut or snagged and your hand or arm may be pulled into the spinning wheel.
- n. **Never lay the power tool down until the accessory has come to a complete stop.** The spinning wheel may grab the surface and pull the power tool out of your control.
- o. **Do not run the power tool while carrying it at your side.** Accidental contact with the spinning accessory could snag your clothing, pulling the accessory into your body.
- p. **Regularly clean the power tool’s air vents.** The motor’s fan will draw the dust inside the housing and excessive accumulation of powdered metal may cause electrical hazards.
- q. **Do not operate the power tool near flammable materials.** Sparks could ignite these materials.



# SAFETY INSTRUCTIONS FOR CUTTING-OFF OPERATIONS



## Cut-Off Machine Safety Warnings - Kickback and Related Warnings

Kickback is a sudden reaction to a pinched or snagged rotating wheel. Pinching or snagging causes rapid stalling of the rotating wheel which in turn causes the uncontrolled power tool to be forced in the direction opposite of the wheel's rotation at the point of the binding.

For example, if an abrasive wheel is snagged or pinched by the workpiece, the edge of the wheel that is entering into the pinch point can dig into the surface of the material causing the wheel to climb out or kick out. The wheel may either jump toward or away from the operator, depending on direction of the wheel's movement at the point of pinching. Abrasive wheels may also break under these conditions.

Kickback is the result of power tool misuse and/or incorrect operating procedures or conditions and can be avoided by taking proper precautions as given below.

- a. Maintain a firm grip on the power tool and position your body and arm to allow you to resist kickback forces. Always use auxiliary handle, if provided, for maximum control over kickback or torque reaction during start-up.** The operator can control torque reactions or kickback forces, if proper precautions are taken.
- b. Never place your hand near the rotating accessory.** Accessory may kickback over your hand.
- c. Do not position your body in line with the rotating wheel.** Kickback will propel the tool in direction opposite to the wheel's movement at the point of snagging.
- d. Use special care when working corners, sharp edges, etc. Avoid bouncing and snagging the accessory.** Corners, sharp edges or bouncing have a tendency to snag the rotating accessory and cause loss of control or kickback.
- e. Do not attach a saw chain, woodcarving blade, segmented diamond wheel with a peripheral gap greater than 10 mm or toothed saw blade.** Such blades create frequent kickback and loss of control.
- f. Do not "jam" the cut-off wheel or apply excessive pressure. Do not attempt to make an excessive depth of cut.** Overstressing the wheel increases the loading and susceptibility to twisting or binding the wheel in the cut and the possibility of kickback or wheel breakage.



# SAFETY INSTRUCTIONS FOR CUTTING-OFF OPERATIONS



## Cut-Off Machine Safety Warnings - Kickback and Related Warnings (continued)

- g. When wheel is binding or when interrupting a cut for any reason, switch off the power tool and hold the power tool motionless until the wheel comes to a complete stop. Never attempt to remove the cut-off wheel from the cut while the wheel is in motion otherwise kickback may occur.** Investigate and take corrective action to eliminate the cause of wheel binding.
- h. Do not restart the cutting operation in the workpiece. Let the wheel reach full speed and carefully re-enter the cut.** The wheel may bind, walk up or kickback if the power tool is restarted in the workpiece.
- i. Support panels or any oversized workpiece to minimize the risk of wheel pinching and kickback.** Large workpieces tend to sag under their own weight. Supports must be placed under the workpiece near the line of cut and near the edge of the workpiece on both sides of the wheel.
- j. Use extra caution when making a “pocket cut” into existing walls or other blind areas.** The protruding wheel may cut gas or water pipes, electrical wiring or objects that can cause kickback.

# SAFETY INSTRUCTIONS FOR CUTTING-OFF OPERATIONS



## Cut-Off Machine Safety Warnings - Additional Safety Rules

**WARNING:** Avoid cutting in the upper quadrant of the blade, especially when beginning the cut. This area is highly likely to lead to kickback.

**WARNING:** When cutting plastics, do not allow the plastic to melt. If the plastic melts, it can stick to the blade, leading to kickback.



# ELECTRICAL CONNECTION

The network voltage must conform to the voltage indicated on the tool name plate. Under no circumstances should the tool be used when the power supply cable is damaged. A damaged cable must be replaced immediately by an authorized Customer Service Center. Do not try to repair the damaged cable yourself. The use of damaged power cables can lead to an electric shock.

**WARNING: Never operate a damaged machine. Always tag a damaged machine and take it out of service until repairs can be made.**

The connection between the power converter and the motor is by a special motor coupling cable. To connect, unscrew the cap, align the tangs, push in, and screw on the collar. Take care to avoid bending the pins. Keep the cap on when not in use. Do not alter this plug in any way.

## 3 Phase Power:

Ideally, the power converter should be supplied with 380V to 480V three phase power for maximum performance. If the plug does not match the available outlet, a suitable plug can be mounted by a qualified electrician.

## Single Phase Power:

In situations where 3 phase power is not available, this machine may also be run on 220V to 240V single phase power with slightly reduced power. Use the single phase adaptor cable. Using the single phase adaptor cable, the current is limited to 16A.

## Power Supply Connections: Three Phase and Single Phase

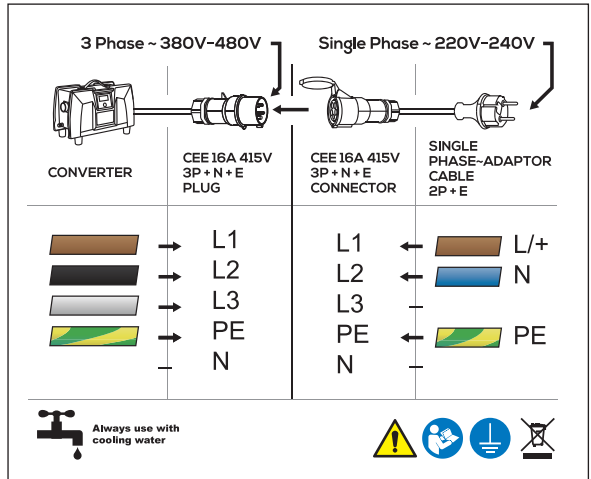

If more power is needed, and a 32A or larger breaker is available, the main plug may be removed, and the converter's main power supply cable may be directly wired to the breaker. In this case, connect the L1 and L2 wires to the breaker, leaving the L3 wire unconnected. Then connect the earth (ground) wire to the earth connection.

**NOTE: The above action may only be performed by a qualified electrician.**

# INTRODUCTION

This machine is a special, high frequency PMSM (permanent magnet synchronous motor) power tool which must be used in conjunction with its high frequency power converter for its power supply. This converter takes 220 to 480V, 50Hz or 60Hz, single or three phase supply and converts it to up to 600Hz for use with the motor. Connection between the converter and motor is made by a motor coupling cable with special plug. The converter has a three phase power supply plug and a single phase adaptor plug for use with single phase supply. Maximum performance is obtained using 380V to 480V, three phase power supply. Performance will be reduced when using 220V to 240V three phase or single phase supply due to electrical current limitations.

This machine is equipped with two handles and a blade guard. It has an integrated water feed system as required for cooling and diamond cutting. The power converter has a built-in residual current device (RCD) for electrical safety as well as overload, thermal, under voltage and over voltage protection. It must only be used with a diamond blade. It is intended for cutting masonry, stone, concrete, reinforced concrete and similar materials. All other uses are prohibited.

## LIST OF CONTENTS

- Ring Saw
- Guide Roller Assembly
- Face Spanner Wrench
- T-Handle Box Wrench

## LIST OF OPTIONAL CONTENTS

- Power Converter
- Water Coupling Hose
- Single Phase Adaptor Cable

## ASSEMBLY

- Mount the blade. ( See below “Mounting the Blade”)



# DIAMOND BLADES

## Allowed Types Of Blades

This machine may only use diamond ring saw blades.

- Only use either segmented or continuous rim diamond blades.
- If the diamond blades are segmented, the maximum allowable peripheral gap between segments is 10mm and must be with a negative rake angle.
- Only diamond ring saw blades of 400mm (15-3/4") diameter of the 3 groove style (Hycon type) may be used.

## Blade Storage And Transport

Store the machine and blade in such a way that it is protected from being bent or damaged when the machine is not in use.

A damaged blade can cause irregular conditions, which can cause imbalance and result in a hazard.

Always inspect new blades for storage or transport damage.

## About Diamond Blades

Diamond blades consist of a steel core with diamond segments added to its periphery. Diamond blades are available for different hardnesses of masonry materials, stone, concrete, reinforced concrete, etc. This machine must

This machine must always be used with water, since it requires water for converter and motor cooling. Water will prevent the blade from overheating, greatly reduce the amount of harmful dust created by cutting, remove the slurry from the cut, and extend the life of the blade.

The diamond impregnated segments operate on a principle of controlled erosion. The bond matrix holding the diamonds is continually worn away by abrasion with the workpiece, exposing the harder diamonds to stand proud from the bond matrix. Blades made for cutting harder materials will have a softer bond, allowing the diamonds project more aggressively (but will not last as long). Blades made for cutting softer, abrasive materials will have a harder bond, allowing them to resist the abrasiveness of the material and to last longer. Without enough erosion of the bond matrix (the diamonds not exposed) and the blade becomes dull . This is called glazing . If the blade seems to refuse to cut anymore, it is glazed.

# DIAMOND BLADES

## About Diamond Blades (continued)

See below: **"Sharpening a Glazed Blade"**

Never use a sharp motion or the blade will be damaged. Conversely, don't feed too gently or the diamond segments will become glazed. Keep the blade steadily working.

Take great care to keep the blade perpendicularly aligned to the kerf. If the blade is crooked, it will easily bind. When cutting reinforced concrete, if embedded steel is encountered, take special care. Reduce the feed pressure by about 1/3 and let the blade go at its own pace, if there is too much vibration the blade may be destroyed. Once the steel is passed, continue normally.

**WARNING: Never use blades for cutting a material other than the material they were intended for.**

## SHARPENING A GLAZED BLADE

Diamond blades may become glazed (dull). Once the diamond segments are glazed, the blade's cutting performance will degrade and the segments will overheat. To sharpen the blade, turn down the water feed and make a few cuts in a very soft, abrasive material such as brick or an alumina oxide or silicon carbide dressing stone.



# MOUNTING THE BLADE

First make sure that the machine is unplugged.

1. Loosen the drive tensioner knob fully.
2. Loosen the thumb knob and slide the drive wheel cover plate out of the way. Remove the drive wheel if it is fitted.
3. Loosen both guide tensioner knobs fully.
4. Fit the blade in position with its grooves facing the male grooves in the guide wheels.
5. Fit the drive wheel on the spindle. Using the face spanner wrench to immobilize the wheel, tighten the arbor bolt using the T-handle box wrench.
6. Tighten one guide tensioner knob, just enough to keep the guide wheel from slipping on the blade. (Wearing gloves, grab the blade and rotate it back and forth while holding the guide wheel to check that it will not slip.) **Do not over tension the guide tensioner. Overtensioning will unnecessarily increase the load on the motor and increase wear on the mechanism.** Repeat for the other guide tensioner.
7. Wearing gloves, grab the blade and rotate it back and forth while turning in the drive tensioner knob until there is enough tension so that the blade is turning the drive wheel without skidding. Then tighten a further 1/4 turn. **Do not over tension.**
8. Slide the drive wheel cover plate into position over the drive wheel and tighten the thumb knob.

**NOTE: Always replace the drive wheel with a new one when replacing a worn blade. The drive wheel and blade wear together and should be replaced as a set.**

Inspect the blade before use. It must not be cracked, warped or damaged in any way that would cause a hazard in operation. Loose diamond segments can be ejected at high speed, causing possible injury. Always check that the diamond segments are not under cut. If the diamond segments are thinner or nearly thinner than the blade core, the kerf will be too tight fitting and could easily lead to kickback.

Inspect the blades for segment damage, arbor hole damage or any other damage which could cause hazardous operation.



# SPLASH GUARD

The spring-loaded splash guards are useful to help contain slurry which splashes toward the back. The upper guard has an over-center spring which will lock into the fully open position if it is pulled all the way back. The lower guard has a clip which can be used to lock the guard in the fully open position.

## WATER CONNECTION

Water is a basic requirement for this tool and is essential for cooling of the motor and converter. The water also serves as a coolant to avoid the working surface of the diamond segments from overheating. Water also keeps down dust and flushes away abrasive particles.

The converter has 2 water connections. Connect the water supply to either connection on the converter first and then connect the other connection to the motor using the water coupling hose.

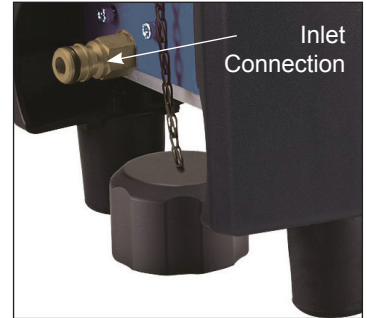

**CAUTION: NEVER OPERATE THIS TOOL WITHOUT WATER FLOW THROUGH BOTH THE CONVERTER AND THE MOTOR.**

**CAUTION: WHEN OPERATING IN FREEZING WEATHER CONDITIONS, ALWAYS ENSURE THAT THE WATER IS DRAINED COMPLETELY FROM THE MOTOR AND CONVERTER AFTER USE, Water freezing inside the machine will lead to severe damage!**

It is designed to be water cooled and would quickly overheat without water.

**WARNING: Check all connections of the water feed system to ensure there are no leaks. Inspect hoses and other critical parts which could deteriorate.**

**WARNING: The maximum water pressure should not exceed 70 psi (4 bar).**

**Note: Use a wet vacuum to collect cooling water if nearby objects could be damaged by water.**



# WATER CONNECTION

The water flow is controlled by the water feed valve. The water to the blade may be finely adjusted to the required amount.

**NOTE: Contaminants in the water supply can easily plug up the fine water nozzles in the blade guard. Ensure that the supply water is clean. If you find that there is no water flow to the blade, then clean out the water feed system on the machine with compressed air.**

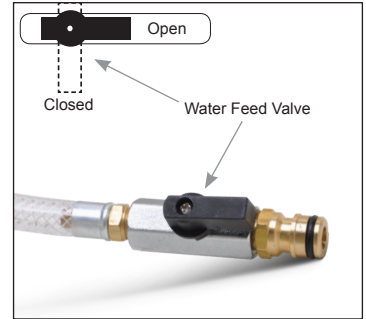

## OVERLOAD PROTECTION, OVERHEAT PROTECTION

### Overload & Load Warning Lamp

Whenever the motor is energized, and when it is operating comfortably within its load range, the load warning lamp will be lit green. Whenever the motor is energized, and when it is operating comfortably within its load range, the load warning lamp will be lit green. When the motor is operating near its full load range, the load warning lamp will flash red. If full load is exceeded and sustained for too long, the motor will shut down and the load warning lamp will glow solid red. In this case, the motor must be first shut off and then restarted.

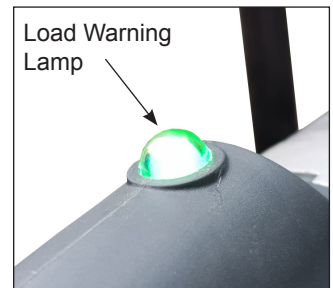

**NOTE: When using single phase 16A power, the operator must be very careful not to use too much force. One must make note of the load warning lamp and try to keep within the green range. Too much load will draw too much current and easily trip the supply circuit breaker.**

### Overheat Thermal Protection

If the temperature of the motor gets too high, the thermal protection will shut the motor down. The switch must be first shut off and then restarted. When this happens, do not immediately start cutting. Always allow cooling water to flow through the motor for a few minutes to return to a normal operating temperature before continuing.

# OPERATION

- Connect the water supply from the converter to the motor using the water coupling hose
- Connect the converter to the water supply
- Check for water leaks
- Connect the motor coupling cable to the converter
- Connect the converter to the power supply
- When the power converter power supply cable is plugged in, the supplied voltage will be displayed on the LCD screen
- Press the **POWER** button on the power converter to energize the motor. "ON" will be displayed on the LCD screen and the Load Warning Lamp on the motor will be lit green. This indicates that the motor is now live and may be operated by its trigger switch.



## The Switch:

To start the machine, first press the Release Button, then press the Trigger Switch.

To stop the machine, release the Trigger Switch, then press the Power Button on the power converter to de-energize the machine.



## How to hold the machine

- Always hold the machine with both hands, with the right hand on the main handle and with the left hand on the side handle. (This applies even if the operator is left-handed)
- Do not stand directly in line with the blade. Rather, stand in such a way that, if it kicks back, you will not be in the path of the blade.
- Never lean over the blade path. That would put your body in line with the blade if it kicks back.
- Do not cut above shoulder height.
- Never cut while standing on a ladder or other unstable platform.

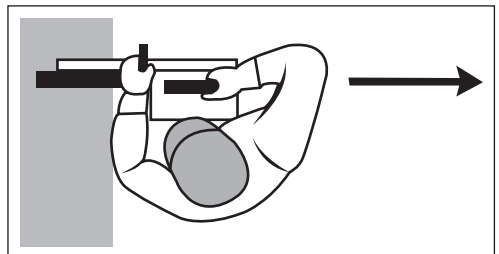

# OPERATION

## Before cutting

- Check the area where the cut is to be made to ensure that it is clear of objects which could cause the operator to stumble.
- Before cutting, it is sometimes useful to mark the line of cut with chalk or the like. For straight cutting, a wood plank is also useful in guiding the machine to make a straight cut.
- Ensure that all bystanders are at a safe distance.
- Ensure that all safety equipment is in place.

## Proper Support for the Workpiece

- Support the workpiece on in such a way that the kerf will not pinch down on the blade.
- Secure the workpiece so that it will not roll, slip away or move due to vibration while cutting
- The cutting sequence is important when making cutouts. Always make the last cut in a way that avoids the blade being pinched. Thus, make the bottom horizontal cut first, then the sides and finally make the top horizontal cut last.
- Make note of the weight of the workpiece and the direction which it will fall when it is cut through.
- Whenever there is a situation where severing the workpiece will cause a hazardous situation, leave a tab of material intact and finish off the operation with a chisel or the like.

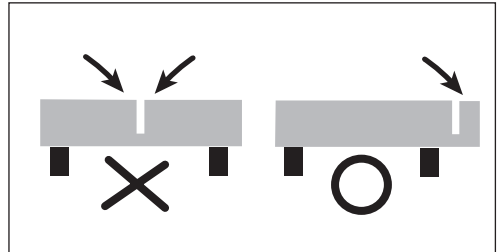

## Cutting Technique

- Holding the machine with both hands to resist the start up torque, press the release button and then squeeze the trigger switch.
- Allow the machine to reach full speed before contacting the workpiece.
- Adjust the water flow as needed by turning the water feed valve.
- Then gently begin the cut with the rear portion of the blade until the kerf is established.
- It's a good idea to pre cut a guiding groove using a conventional circular diamond saw with a wide kerf blade before proceeding to make the main cut with the ring saw. This will save wear on the ring saw blade. Take care to avoid the blade being pinched.
- In round workpieces, the best technique is to use a slow, uniform back and forth motion while cutting with the bottom quadrant of the blade.
- Never side load the blade in the kerf.

# OPERATION

## Stopping

Release the trigger to stop the machine. After the trigger is released, the blade will continue spinning for a short time. Once the machine is fully stopped, press the Power button on the power converter to de-energize the motor.

**WARNING: Do not set the machine down until the blade has stopped turning.**

# MAINTENANCE AND CLEANING

This machine operates in a very harsh environment.

Therefore, it's essential for the long life of the tool that it be thoroughly cleaned after each use.

## Daily Maintenance

- Keep the machine clean
- Check to ensure that the motor coupling cable, power supply cables and water coupling hoses are in good condition.
- Ensure all screws are tight.
- Check the condition of all safety equipment such as the blade guard
- Check the blade for damage.
- Ensure that the guide tensioners and drive tensioner are properly adjusted.

**If the replacement of the power supply cord is necessary, this has to be done by the manufacturer or their agent in order to avoid a safety hazard.**

**WARNING: All repairs must be entrusted to an authorized service center. Incorrectly performed repairs could lead to injury or death.**

Do not throw electric power tools into the household waste!

In accordance with the European Directive 2002/96/EG on Waste Electrical and Electronic Equipment and transposition into national law, used electric power tools must be collected separately and recycled in an environmentally friendly manner.

# POWER CONVERTER LCD SCREEN CODES

**OFF:** When the converter is plugged in, the screen will display the supply voltage.  
The voltage displayed will depend on the voltage of the supply

**ON:** When the converter power button is pressed, the screen will display “ON”  
The connected tool is now live

## ERROR CODES

<b>8888</b>	<b>Loss of communication between the motor electronics board, the converter electronics board and the LCD module when powering up</b>	Check the connection of the coupling cable
<b>E1</b>	<b>Overload of the converter.</b>	At the tool, turn the switch OFF and then ON again
<b>E2</b>	<b>Overheat of the converter</b>	Ensure that water is flowing. As soon as temperature returns to normal, at the tool, turn the switch OFF and then ON again
<b>E3</b>	<b>Under voltage</b>	As soon as supply voltage returns to normal, at the tool, turn the switch OFF and then ON again
<b>E4</b>	<b>Over voltage</b>	As soon as supply voltage returns to normal, at the tool, turn the switch OFF and then ON
<b>E5</b>	<b>Excessive back voltage from the motor brake to the converter</b>	At the converter, press the POWER button to turn the power OFF and then back ON again (If the problem persists, bring the unit to an authorized service center for repair)

# ERROR CODES

<b>E6</b>	<b>RCD current leak detection between the converter and the voltage supply</b>	Check connections and then, at the converter, press the POWER button to turn the power OFF and then back ON again (If the problem persists, bring the unit to an authorized service center for repair)
<b>E7</b>	<b>Hall effect sensor error</b>	At the converter, press the POWER button to turn the power OFF and then back ON again (If the problem persists, bring the unit to an authorized service center for repair)
<b>E8</b>	<b>Motor overheat</b>	Ensure that water is flowing and wait 20 seconds. Then, at the tool, turn the switch OFF and then ON again (If the temperature has still not dropped sufficiently after 20 seconds, wait longer for the temperature to drop to the acceptable range)
<b>E91</b>	<b>Loss of communication between the converter electronics board and LCD module during operation</b>	At the converter, try pressing the POWER button to turn the power OFF and then back ON again. (If the problem persists, bring the unit to an authorized service center for repair)
<b>E92</b>	<b>Loss of communication between the motor electronics board and the LCD module during operation</b>	Check the connection of the coupling cable. Then, at the tool, try turning the switch OFF and then ON again (If the problem persists, bring the unit to an authorized service center for repair)
<b>E10</b>	<b>Poor connections of power supply cable -single phase</b>	Check the connections of the power supply plug and cable



# ERROR CODES

<b>E11</b>	<b>Voltage leak between the converter and the tool</b>	Check connections and then, at the converter, press the POWER button to turn the power OFF and then back ON again (If the problem persists, bring the unit to an authorized service center for repair)
<b>E12</b>	<b>Poor connections of power supply cable –three phase</b>	Check the connections of the power supply plug and cable
<b>E15</b>	<b>Internal problem in the converter electronics board circuit</b>	At the converter, try pressing the POWER button to turn the power OFF and then back ON again (If the problem persists, bring the unit to an authorized service center for repair)
<b>E16</b>	<b>No signal from the motor temperature sensor</b>	At the tool, try turning the switch OFF and then ON again (If the problem persists, bring the unit to an authorized service center for repair)
<b>E17</b>	<b>Motor temperature sensor short circuited</b>	At the tool, try turning the switch OFF and then ON again (If the problem persists, bring the unit to an authorized service center for repair)



# WIRING

## High Frequency Ring Saw:

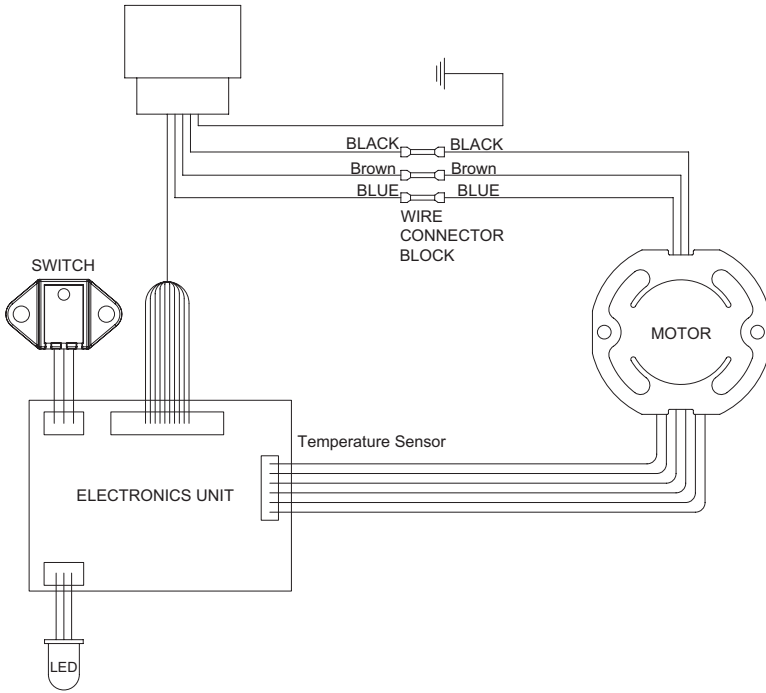

## Power Converter:

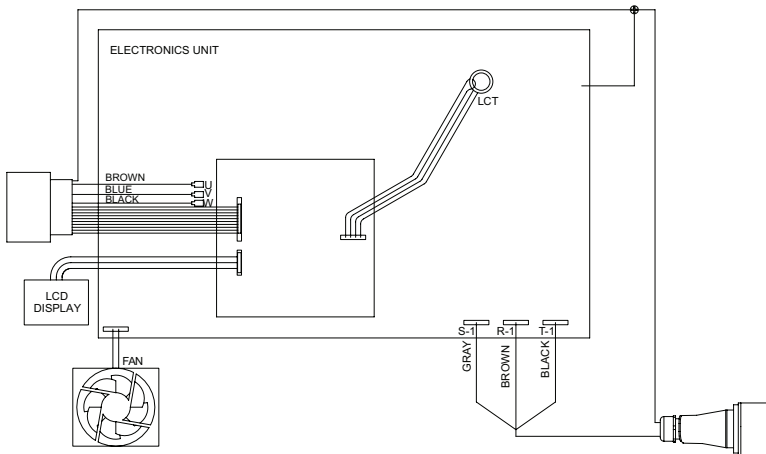

# NOISE AND HAVS VIBRATION LEVELS

## QRS-400

Declared dual-number noise emission values in accordance with ISO 4871						
Measured A-weighted sound power level, $L_{WA}$ (ref. 1pW), in decibels				109,5 dB(A)		
Uncertainty, $K_{WA}$ , in decibels				3 dB(A)		
Measured A-weighted emission sound pressure level at the work station, $L_{pA}$ (ref. 20μPa), in decibels				98,5 dB(A)		
Uncertainty, $K_{pA}$ , in decibels				3 dB(A)		
Vibration total values (triaxial vector sum) determined according to EN60745						
	cutting concrete slab		No load with saw blade		No load without saw blade	
	Main	Auxiliary	Main	Auxiliary	Main	Auxiliary
Vibration emission Value $a_h$	5,5 m/s <sup>2</sup>	5,1 m/s <sup>2</sup>	4,9 m/s <sup>2</sup>	5,4 m/s <sup>2</sup>	1,6 m/s <sup>2</sup>	1,9 m/s <sup>2</sup>
Uncertainty $K$	1,5 m/s <sup>2</sup>	1,5 m/s <sup>2</sup>	1,5 m/s <sup>2</sup>	1,5 m/s <sup>2</sup>	1,5 m/s <sup>2</sup>	1,5 m/s <sup>2</sup>



## APPROVED SERVICE CENTRE;

---

### DIAQUIP HEAD OFFICE | MANCHESTER, UK

- ☎ 0161 406 0609
- ✉ SALES@DIAQUIP.CO.UK
- 🌐 WWW.DIAQUIP.CO.UK

