



 synseal[®]

Conservatory Roof Assembly Guide

Effective from August 2007



Section	Subsection	Page
1. Before you start		3
2. Box gutter	2.1 Fixing & sealing the box gutter	4
	2.2 Joining the box gutter	5
3. Eaves beam	3.1 Fixing the eaves beams	6
	3.2 Fixing the gable support platform	6
	3.3 Joining the eaves beam	7
4. Rafters	4.1 Ridge & radius end rafters	8-9
	4.2 Jack Rafter connection	9
	4.3 Gable end rafter	10
	4.4 Standard valley rafter	10
	4.5 Drop valley rafter	11
	4.6 In-line valley on gable support	12
5. Ridge	5.1 Joining ridges	13
	5.2 Lean to wallplate	13
6. Tie bar	6.1 3 & 5 way tie bars	14
	6.2 In-line tie bar	15
7. Glazing	7.1 Fitting the roof sheets	16
	7.2 Glazing the valley	17
	7.3 Glass roofs	17
8. Sealing	8.1 Fitting the foam bung	18
	8.2 Ridge corner joint	19
	8.3 Ridge 'T' joint	19
9. Ridge top caps	9.1 Ridge & wallplate top cap	20
	9.2 Ridge flashing trim	21
	9.3 Radius end top cap	21
	9.4 Gable end top cap	22
	9.5 Ridge top cap joints	22
10. Guttering	10.1 Guttering	23
	10.2 Gutter union to box gutter	24
11. Internal cladding	11.1 Internal eaves beam cladding	24
	11.2 Internal ridge cladding	25
	11.3 Internal valley cladding	25
	11.4 Box gutter cladding	26
	11.5 Internal wallplate cladding	26
12. Useful information		27



Assembly Guide

1. Before you start

The purpose of this Installation Guide is to assist the Installation Team when erecting a Synseal Roof. All Synseal roofs are individually designed to suit the size and specification requested.

The Synseal Roof will arrive in kit form consisting of a number of packages containing the aluminium skeleton and the PVC-U cappings. Small ancillary items should arrive in a box, in this box you should find a copy of the roof layout plan and this guide.



This roof has 17 packs



The delivery note shows what is in each pack



Each pack has label with descriptions

ROOF LAYOUT PLAN

The roof layout plan is essential as it depicts the size of the roof and the position of the main roof components. Thoroughly check that the roof fits the window frame layout and that all the roof components are present.

Each length of material should be numbered to correspond with its position on the roof plan. An example of this is an eaves beam assembly numbered P17 on the roof plan, the aluminium, gutter and cladding lengths should all be numbered P17 to aid identification.

CARE OF PRODUCTS ON SITE

Although the Synseal roof is robust in construction, simple measures should be taken when handling, storing and erecting the conservatory roof.

When unwrapping the packages take care not to damage components with a knife.

Do not leave PVC-U components outside in freezing conditions then immediately attempt to knock them on.

Do not leave brown components in their packaging whilst in direct sunlight at times of high temperatures.

Store polycarbonate roof panels in a dry safe area until they are required.

SEALING

The Synseal roof requires sealing at important junctions in the roof, the use of Low Modulus, Neutral Cure sealants is vital. Self cleaning glass may have compatibility issues with certain types of silicone based sealants, refer to your glass supplier regarding the use of specific sealants.

TOOLS REQUIRED

The following tools are necessary to install the Synseal Roof:

- | | | | |
|------------------------------------|----------------------------|--------------|-----------------------------|
| 13mm socket and ratchet | White rubber headed mallet | Silicone Gun | 13mm open ended spanner |
| 17mm open ended spanners | Stanley Knife | Spirit Level | Roofing square |
| Power Drill + HSS and Masonry bits | Tape Measure | Hack Saw | Cordless Driver + Pozi bits |
| Long nosed pliers | 45mm dia. hole cutter | Hot air gun | 60mm dia. hole cutter |
| | | | Nylon Roller |

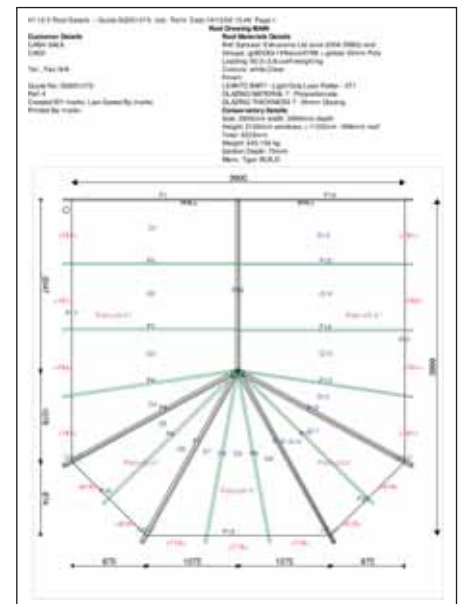

ROOF VENTS

The Synseal Roof can be supplemented with an opening roof vent, refer to the installation instructions found within the roof vent packaging.

This Synseal Assembly Guide has been produced as an aid to assemble the Synseal range of products. All information in this manual is provided for guidance only. Synseal Extrusions Ltd cannot be held responsible for the way in which the information in this manual is

interpreted. We reserve the right to alter specifications and descriptions without prior notice as part of our policy of continual development. All dimensions are in millimetres. Do not scale drawings.



The box gutter requires an adaptor to connect it into the perimeter plastic gutter. Apply 2 beads of silicone to this joint and slide in the adaptor. It is advisable to seal closed the voids in the end of the box gutter prior to fitting the adaptor.



The specialised fitting tape should only be applied when the aluminium is clean, dry and free of grease. Warm the tape with a heat gun and fit it centrally over the joint.



Whilst the joint is warm, use a small nylon roller to give an even compressed seal. Do not leave any air pockets or open edges on the tape.

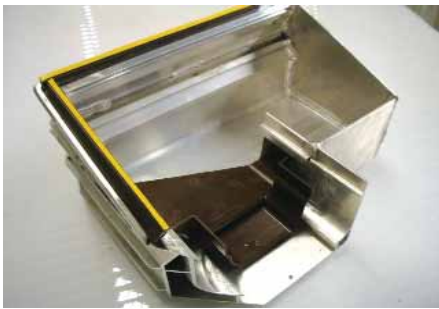

The example above shows 2 special pieces of box gutter fabrication, the raised leg and zero return. The small return on the box gutter requires a welded upstand to accept the box gutter adaptor. The adaptor will need to be modified on site (as shown) prior to fixing.



The raised leg section of the box gutter is welded into the head of the main gutter. Silicone seal this continuous joint or preferably flash over the joint to create a watertight seal.



The box gutter has an optional fixing plate. This fixing plate is fastened back to existing and then the box gutter is swung into it. Ensure that the fixing plate is level and straight before attempting to rotate the box gutter into position.



The box gutter must be fitted level and supported at both ends. Longer box gutters require intermediate support as per the recommendations in the Structural Information guide.



The box gutter can be fastened back without the fixing plate. This raised leg example shows the fastener being secured with a long reach screwdriver through a site drilled access hole in the box gutter inner wall.



Consider the box gutter to eaves beam joint before fixing the box gutter to the building. The mitred joint must be tight and secured with the bracket as shown above.

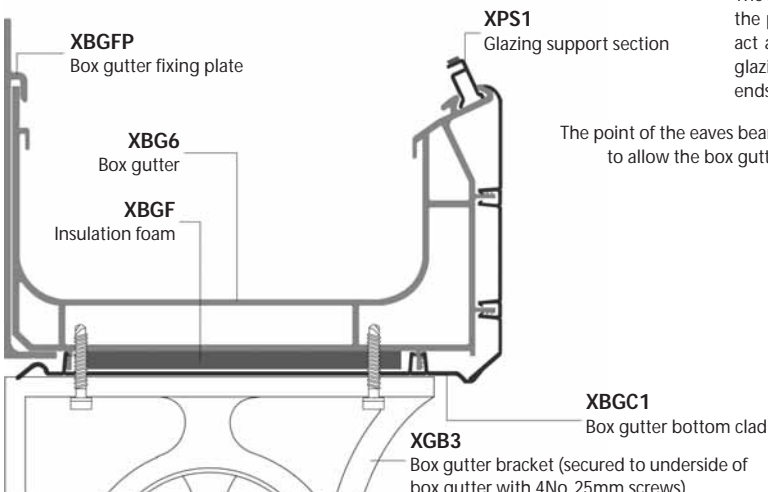

The aluminium box gutter is designed to carry water to the perimeter plastic guttering. It is also designed to act as a beam carrying the weight of the rafters and glazing. The box gutter must be supported at both ends and at recommended centres.

The point of the eaves beam requires cutting off to allow the box gutter adaptor to slide in.

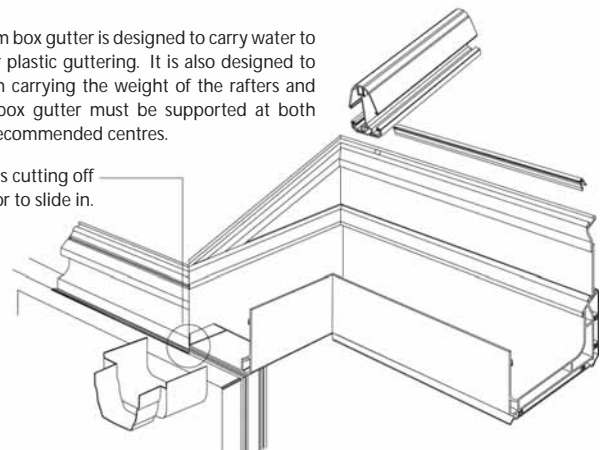

The position of the adaptor is dependant on the type of gutter union connecting to it. The screw lug requires removing as per the example in Section 10.2.

The raised leg gutter detail

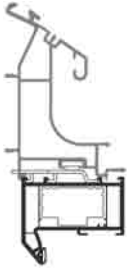

Synseal eaves beam

Before the roof installation commences make sure the conservatory footprint dimensions are correct, with the frames level and plumb. The internal sizes at the head of the frames should correspond with those on the supplied roof plan.

We recommend that silicone is used to form a seal between the head of the frame and the bottom of the eaves beam. **Note:** Do not seal the front of the eaves beam as this will restrict the fitting of the gutter under trim.



Position each eaves beam in turn onto the frame head ensuring the turnbuckles are in the open position. The internal eaves beam leg fits over the inside frame edge. The bottom of the eaves beam must fit down tight to the head of the frame the use of clamps is recommended to achieve this. In the event that a turnbuckle falls over a frame joint or connector the turnbuckle can be removed and a screw fixing used to secure this section of beam to the frame.



Note: It is recommended that when frame connectors are used then they should be cut 3mm shorter than the frame height to allow for the legs on the bottom of the eaves beam.

Once you are happy with the eaves beam setting out, engage each turnbuckle making sure of a positive connection with the frame.



Position the external stainless steel eaves beam connecting bracket centrally between the two extrusion lines on the outside of the eaves beam. Fix the bracket to the eaves beams using the supplied self drilling screws (XM48-13).

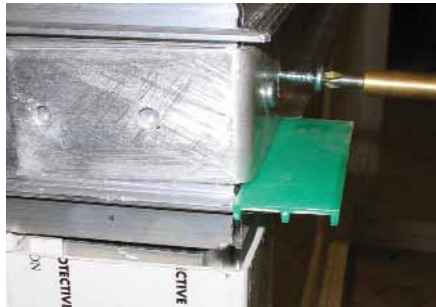

When the eaves beams join to an internal corner a larger connecting bracket is supplied. In this picture a glazing packer has been temporarily used to form a gap between the bracket and cladding bar to allow space for the later fitting of the internal eaves clads.



This bracket is fixed using the supplied self drilling screws (XM48-13).

3.2 Fixing the gable support platform



When a gable support system is used the eaves beam includes a separate aluminium extrusion, which forms the gable platform. Occasionally this section will require fitting into the eaves beam on site.

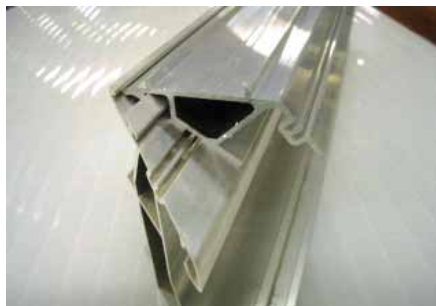

Slide the gable platform into the eaves beams parabolic head. Centralise the platform with the eaves beam or gable frame when used in a gable fronted lean-to.



Lock off the gable platform in to the eaves beam with a 20mm self drilling screw (not supplied).



Find and mark the centre of the eaves beam jointer, slide the jointer in to the eaves beam cavity up to the centre mark.



Fix the jointer to the eaves beam using the supplied 13mm self drilling screws (XM48-13).



Slide the next section of eaves beam over the jointer until it meets the end of the first section of eaves beam.

Note: There are two types of jointer, the type you use will depend on which eaves beam is used (Shield or Global).

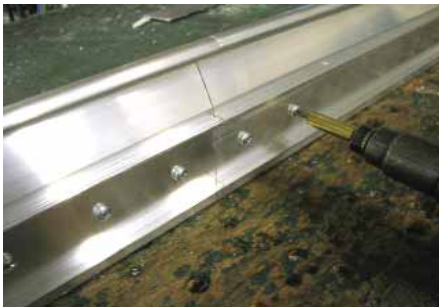

Fix in place using the 13mm self drilling screws (XM48-13).



The eaves beam is now ready for installation.



The eaves beam to box gutter jointer uses a thick aluminium angle for the jointer. Drill 4mm pilot holes to aid fitting the XM48-13 screws.

Eaves beam with gable support

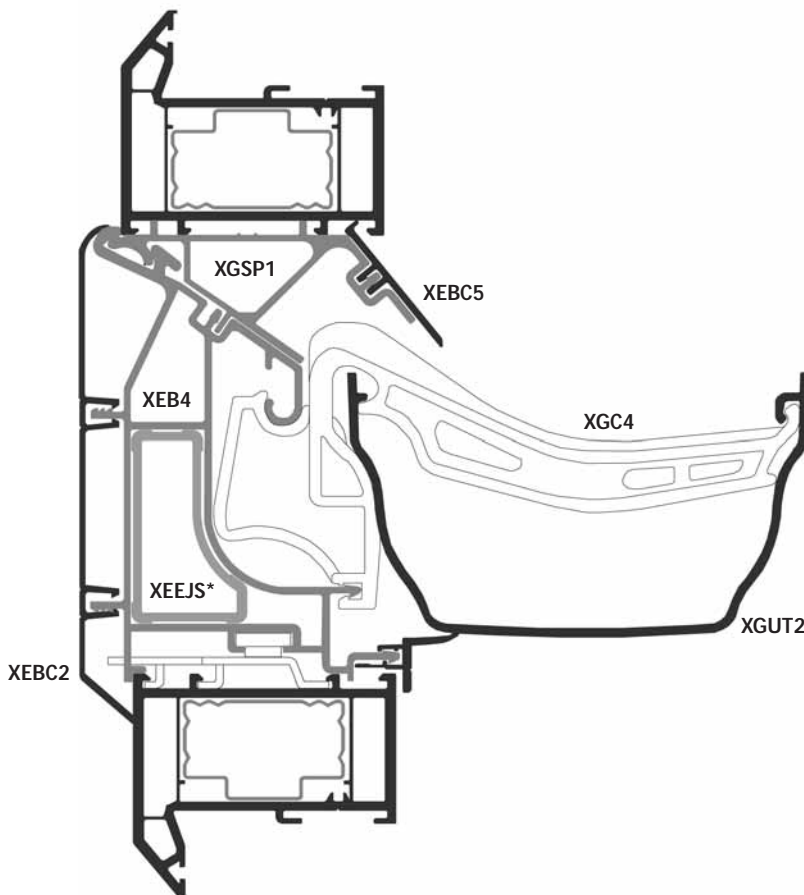

Alternative eaves beams

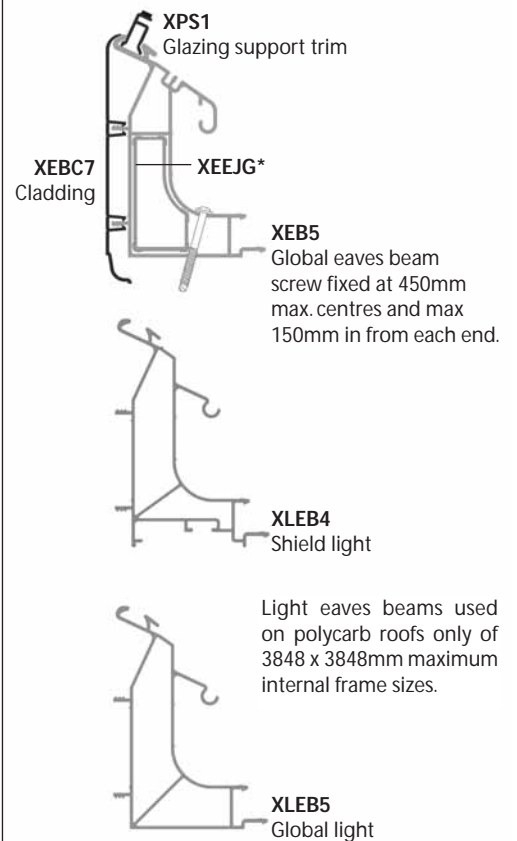

*Eaves beam jointer where appropriate



Before the installation of the rafters it is necessary to install the glazing support adapters. These are designed to fill in the gap left between the shaped rafter bottom cap and the polycarbonate support trim.



These come in two sizes, the larger for Georgian hips and the smaller for Victorian, jacks and transom rafters.

Note: To establish the correct position of a ridge on a gable designed roof place the holes which are drilled at 28mm from the end of the ridge against the house wall. This will leave the holes drilled at 38mm at the front.



Determine the height and position of the ridge and support it in this position. Next locate the main ridge to eaves rafters using the roof plan as a guide to their positions. Each rafters connects into a pre-drilled hole via a single bolt to the top and bottom.

Note: If a security bolt is fitted it is important that this is checked for tightness on site. If it is found to be loose then it must be fully tightened using a 4mm allen key.



Ensure the ridge or wallplate is level and in its correct position prior to securing the rafter bolt with a M8 flanged nut. These need to be securely tightened with a 13mm socket or spanner.

Note: If the fitting of the rafter is restricted where it fits under the canopy of the ridge or wallplate then loosen both security bolts (when fitted) slide back the aluminium rafter to release the bolt. Locate the bolt through the bottom cap and fixing hole, then slide the aluminum rafter back over the bolt into its finished position.



The rafters against the house wall should be secured back using suitable masonry fixings at 600mm maximum centres and a maximum of 150mm in from either end of the rafter. **Note:** drill hole below the soaker level.



Some of the rafters, which fit onto the standard multi-holed radius ends will have a pre-fitted plastic bar end cap and bolt. Make sure the shoulder of this cap fits over the rafter bottom cap before installation.

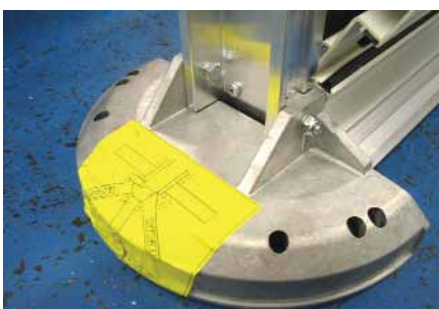

Standard Radius End: When a standard radius is used then the table to the side is used to establish the rafter positions. It is important that each rafter is positioned correctly or problems will arise with the installation of the remaining roof skeleton and glazing.

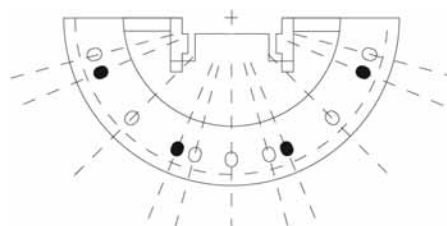

Standard 3 facet Victorian, no centre rafters

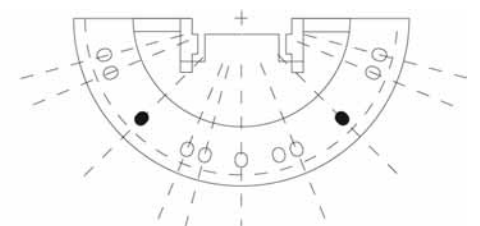

Standard Georgian, no centre rafter

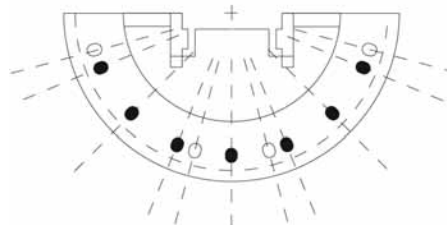

Standard 3 facet Victorian, with centre rafters

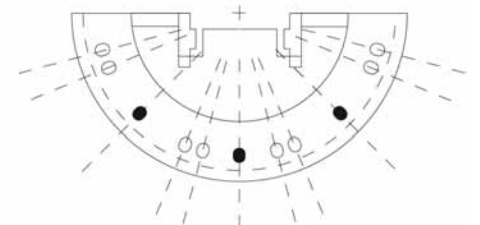

Standard Georgian, with a centre rafter

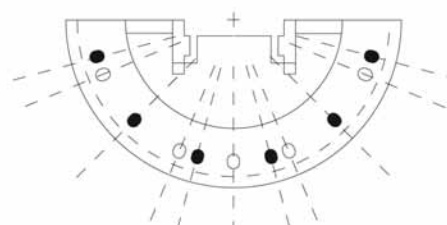

Standard 5 facet Victorian



On Georgian designed roofs the access to the bottom fixing nut of the Georgian hip can be restricted by the shape of the eaves beams. To help gain access for a 13mm socket lift up the back of the hip rafter as shown in the picture above.

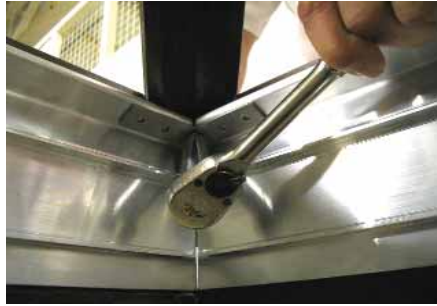

Place the internal stainless steel eaves bracket (XSC2) over the hip bolt then fit and tighten the washered nut. Use a 4mm drill to pilot hole through the four holes in the eaves bracket through the eaves beam.



Secure the bracket with four 10mm screws (XM48-10).

Note: An internal bracket (XSC2) needs to be fitted to every hip rafter.



The non standard radius end (XRE4) will have been pre-drilled in the factory with one hole per rafter. This will also have a pre-fitted clip and bolt to attach the radius end bottom cap.



Some of the rafters will be pre-fitted with an aluminium packer. This has been designed to fit between the rafter and radius end as shown. The rafter is then fixed with a flanged nut on the underside of the radius end.



The purpose of this packer is to raise the height of the rafters so that all of the bottom cap glazing gaskets are at the same level.

4.2 Jack rafter connection



Jack rafters connect onto the hip via a hook fitted to the jack and a spring fitted to the hip. Raise the bottom of the jack rafter and clip the jack hook over the gasket section on the hip rafter. Once the jack is located position the jack rafter bolt into the pre-drilled hole in the eaves beam or valley wing (do not tighten the nut at this time).



Using pliers pull the loop of the spring over the side lug on the jack rafter (do not fit the spring under the main hook).

Note: Check that the hook on the jack rafter does not clash with the hip rafter bolt channel as this could leave a gap between the jack and hip bottom caps.



Pull up the jack rafter bottom cap so that the milled section fits up to the hip rafter bottom cap. If a slight gap is left this can be helped by elongating the bolt hole in the jack rafter bottom cap. Once this joint has been achieved, fit and tighten the fixing nut.

Note: These joints may re-open slightly during glazing. Use a rubber or nylon mallet to tap the jacks back into position.



Assembly Guide

4.3 Gable end rafter

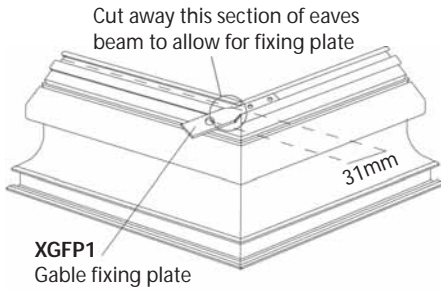

Slide the gable fixing plate (XGFP1) in to the bolt slot of the side eaves beams and fix in place with two 10mm screws (XM48-10). Position the plate so that the centre of the 10mm hole is 31mm away from the bolt slot centre line of the front eaves beam.



Position the end rafter with the top bolt in the pre-drilled hole in the ridge and the bottom bolt through the gable fixing plate. Fasten the rafter by screwing through the outside of the rafter in to the gable frame.



Install the gable frame and infill wedges as described in the in-line gable section.



Place the rafter to frame coupler (PCO1) over the gable frame and fit up to the ridge. Mark and cut the coupler so that it finishes level with the end of the infill wedge.

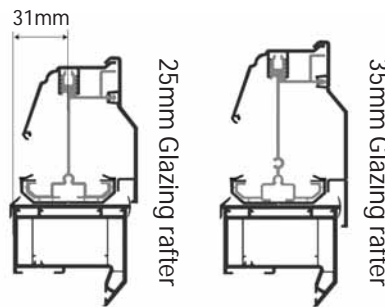

Glaze the roof as described in the glazing section. The end rafter side cap is fitted over the rafter top cap and clipped on to the end rafter as shown above.

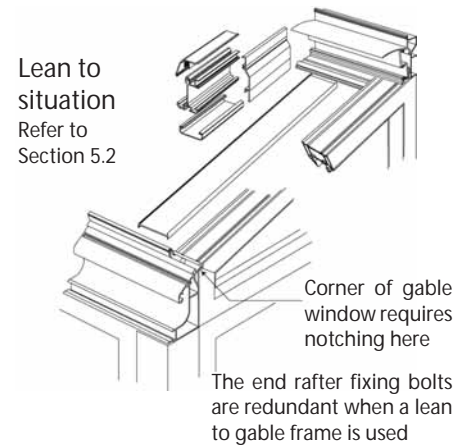

4.4 Standard valley rafter



It is important to seal the joint between the two rain excluders. **Note:** It is advisable to erect as much of the roof as possible prior to installing the valley rafter. Check to make sure the ridge, wallplate and eaves beams are level and square and match the dimensions on the supplied roof plan.



A roof with a valley will have been pre-built in the factory. The 3 aluminium components of the valley will arrive arrow-headed at the top and bird mouthed at the bottom. The valley wings will have been pre-drilled in the factory for the connection of the valley and for the connection of the valley jack rafters.



Position the valley rafter so that the holes at the top and bottom of the valley wings match through with those in the ridge, wall plate and eaves beams. The valley rafter can now be bolted in place.



Seal the three valley rafters components back to the ridge, wallplate and rain excluders.



The valley jacks can now be installed by bolting them through the pre-drilled holes in the valley wings, ridge and wallplate.

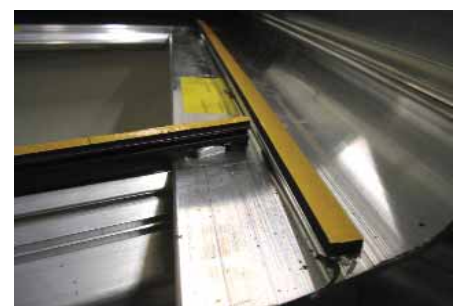

Finally install the glazing support trim (XPS1), which will be pre-notched to fit over the valley wing and connecting bolt.



Establish the position of the wallplate and fasten back to the house wall making sure the wallplate is level. The wallplate should be fixed back at every rafter position (see drawing in Section 9.1).



Place and position the valley so that the pre-drilled holes in the valley line through with those in the eaves beams and wallplate.



The valley wing, which misses the wallplate, is designed to fit up to the house wall.

Note: Occasionally, depending on the roof design, the central valley body may also fit up to the house wall.



Seal the valley body and wing to the wallplate and rain excluder.



Seal the valley wing to the house wall.



Install the end rafter to the valley wing and ridge and securely fasten back to the house wall.

Note: Make sure that the fixings through the end rafter fall below the soaker channel the drill position is marked with an extrusion line along the rafter.

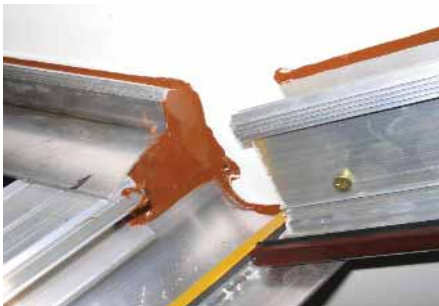

Seal along the top and the end of the wallplate and along the top of the soaker rafter.



Glaze the valley as described in the glazing section. Fit the wall rafter top cap and seal the end to the wallplate.



Fit the wallplate top cap this will run over the wall rafter top cap.



Scribe and cut the valley top cap around the wallplate top cap. This should be cloaked in lead during the flashing stage.



Finished picture showing a correctly cladded drop valley.



Position and fix the gable support platform as shown in the eaves beam section. Fit the external eaves clad (XEBC5) on to the gable platform.

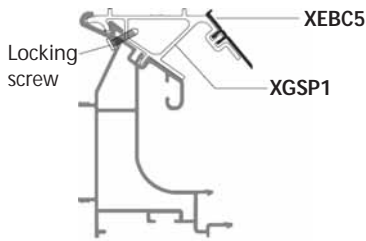

Place the gable frame on to the gable platform. Once it has been correctly positioned so that it is in-line with the frames below, hold it in place by fixing down through the frame in to the platform.

Note: The gable platform has been designed for use with Synseal products. Occasionally when used with an alternative profile the inner legs may require removing to allow for the correct positioning of the gable frame.

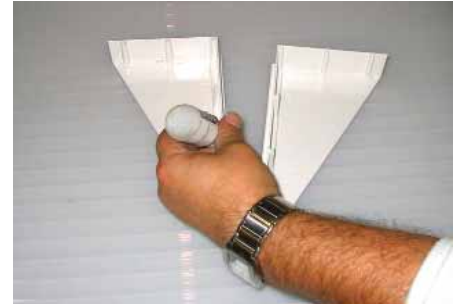

The gable infill wedges have been designed for roof pitches from 25° to 35°. If the roof pitch is greater than 25° then the wedges will need to be cut to suit the new roof pitch. Lines have been included inside each section of the infill wedge to assist with this process.

Glue the two sections together and insert the insulating wedge before installation.

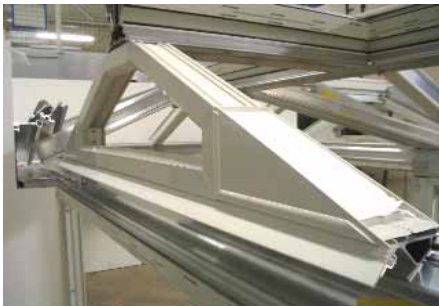

Once the wedges have been installed they should match the line of the gable frame.

Note: Gable frames must be face drained.



Install the top of the valley as previously described in the rafters valley section.



The bottom of the valley is positioned so that the pre-drilled hole in the valley wing, lines through with the pre-drilled hole in the eaves beam.

Once the valley wing has been fastened install the glazing support trim (XPS1).



Check that the cladding barbs on the bottom of the valley wing do not sit over the infill wedge as this will wrongly position the height of the valley wing. These can be easily cut back with a grinder or hacksaw so that they finish just inside the frame line.



Mark and cut the rafter to frame coupler (PC01) so that it fits up to the valley wing.

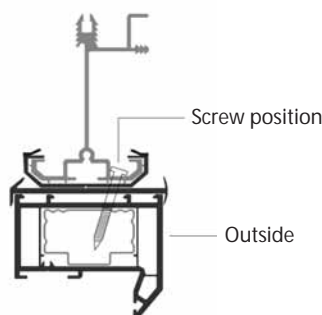

The rafters can now be installed on to the valley.

Note: The bolts in the end rafters are only used for rafter location. The rafter is secured by fastening through the outside of the rafter with screws in to the gable frame at 300mm centres.



5.1 Joining ridges

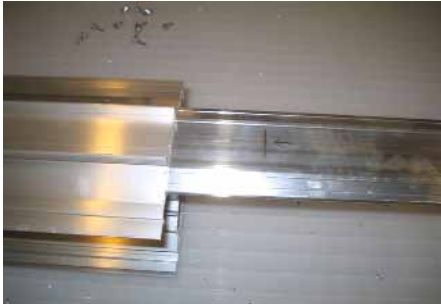

Slide the aluminium joiner half way into the body of one ridge.



Secure the joiner with 4 No. XM48-13 screws each side of the ridge.



Clip in and secure the lower ridge joiner with 4 No. XM48-13 each side.



Slide the other ridge body onto the joiners and repeat the fixings procedure.



The view of the lower ridge joiner connected via 8 No. XM48-13 screws.

XRJV1 Variable ridge joiner

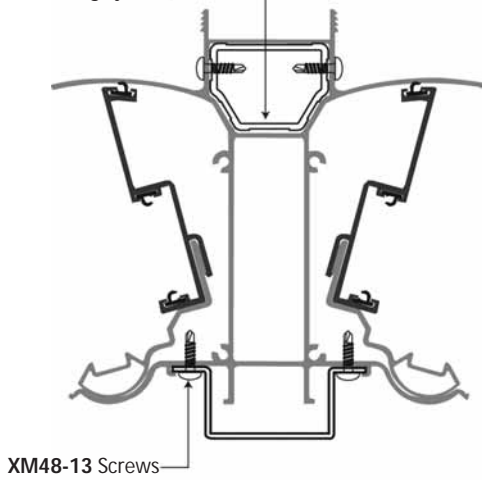

XRJF1 Fixed ridge joiner

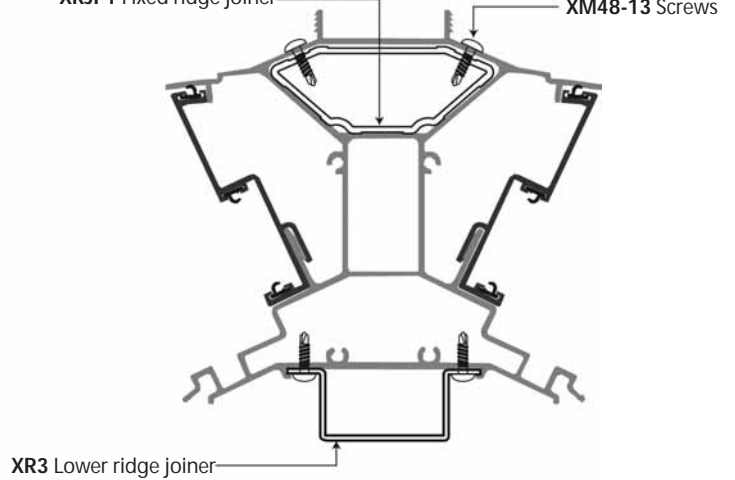

Option 1

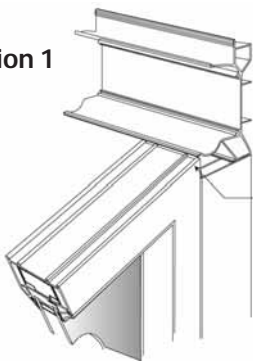

Corner of gable window requires notching here

Option 2

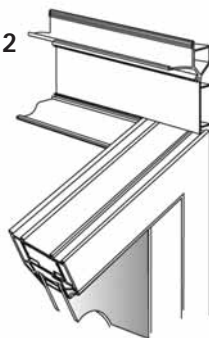

The wallplate sits on a corner post fitted between the house wall and gable window frame.

The wallplate is notched to fit around the gable window frame. This frame is fixed directly back to the house wall.

Note: The wallplate should be fixed back to the house wall at every rafter position using suitable masonry fixings.

5.2 Lean to wallplate



When a gable frame is used, the end rafter top and bottom bolts become redundant. Screw fix the end rafter to the head of the gable window as shown at 300mm centres.



Place the tie-bar bracket on to the factory fitted bolts and fasten using the supplied 13mm nuts.

Note: If the bracket is a tight fit over the bolts, loosen the security bolts with a 4mm allen key fit the bracket and re-tighten the bolts.



Clip the ridge under channel (XR3) in to the bottom of the ridge so that it is in-line with the tied rafters and fix using 13mm self-drilling screws (XM48-13).



Place the ridge under cladding on to the bottom of the ridge and clip it in to position using a rubber or nylon hammer.



Centralise the ridge tie-bar bracket with the tied rafters making sure it runs in-line with the ridge. Drill four 5mm pilot holes and fix using the four supplied screws within the tie-bar kit. Cover the screws heads with the push on screw covers.



Fasten the clevis to the bracket using a bolt and 17mm nut. On a three-way tie-bar three clevises will be required, one for each rafter and one for the ridge.



Determine and cut the 3 lengths of threaded rod and rod covers. Screw one end of each rod at least 20mm into each clevis. Slide on the rod covers then push the remaining ends into the central boss.



Tighten the three nuts in the central boss with a 17mm spanner until the window frames are plumb and the internal roof dimensions are correct. Make sure the rods are plumb and level.



Use the supplied double sided tape to fit the central boss covers to both sides.



Cover all of the exposed nut and bolt heads with the supplied push on cover caps.

To establish the length of the rod covers, assemble the tie bar with just the threaded rods then measure for the covers. The tie bar will then require re-assembly.

5-way tie bars

These are generally supplied on hip-back 'p' shape designs as part of a designed tie bar system.

Depending on the layout of the roof, this system can incorporate other 3 or 5 way tie bars as the drawing (right) illustrates.

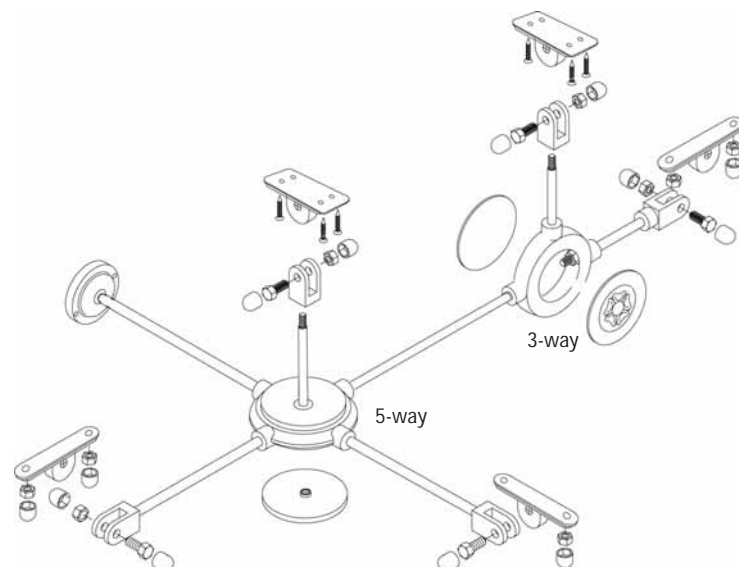



Assembly Guide

6.2 In-line tie bar

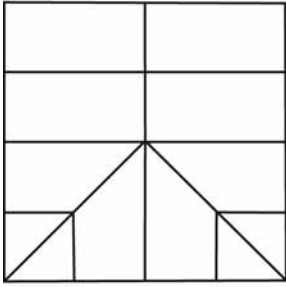

This option of tie-bar is used when the centre of the tied rafters run in-line with the end of the ridge.

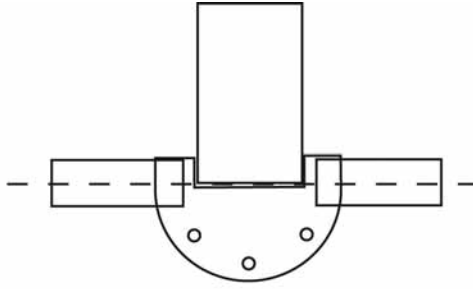

In this situation the tied rafters will be fitted on to the radius end, which will be the XRE4 non-standard radius end.



Remove the bottom two machine screws, which hold the radius connector (XRE1) to the ridge. Place the tie-bar bracket (XTBRC1) over the removed screw holes and fix using the removed machine screws.

Note: The radius end (XRE4) has been removed for photographic purpose only.



Picture showing the position of the tie-bar bracket once installed.



Fit the bracket and clevis to the two rafters as described in the standard tie-bar section. Determine and cut the threaded rods and rod covers and screw the rod ends in to the clevises.



Place the rods in to the central boss, making sure they are level. Measure and cut the drop rod making sure it passes through the top bracket.



Fit the radius end bottom cap (XREC2) this will be pre-drilled with a 10mm hole. Pass the drop rod through the bottom cap and bracket and fit the 17mm nut to the end of the rod.



Fit the rod covers and tighten the nuts within the centre boss until the frames are plumb.



Cover all of the exposed bolt heads and nuts with the supplied cover caps.



Fit the two central boss covers using the supplied double sided tape.

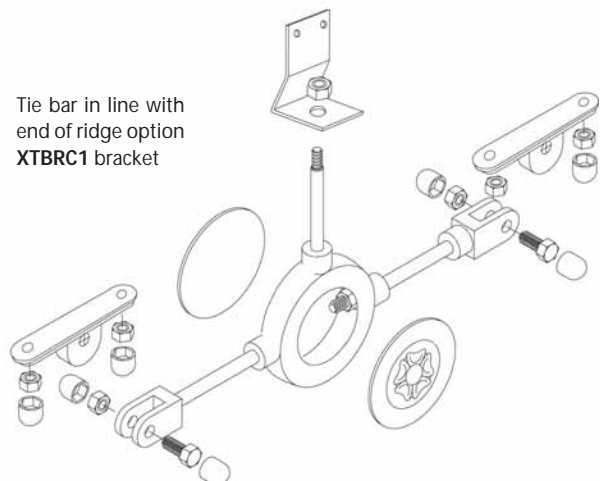

Tie bar in line with end of ridge option XTBR1 bracket



Careful consideration must be given to the sequence of glazing a conservatory roof. Please consider the following points:

- Sequence the glazing so access is available for sealing the critical ridge areas
- With glass roofs, sequence the glazing so loadings are progressively balanced across the ridge
- Allow access to box gutters for fixing of rafter end caps

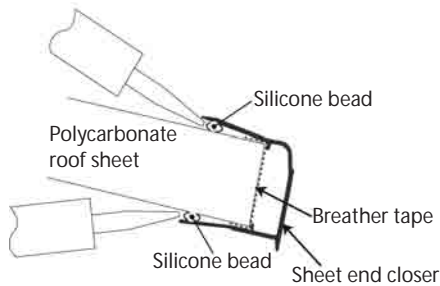

Cut the sheet closer to the bottom width of the panel and remove the drip 20mm in from each end. Slide the closer onto the end of the panel. Push the sealant nozzle under the lip of the closer and run a continuous line to form a seal onto the roof sheet.

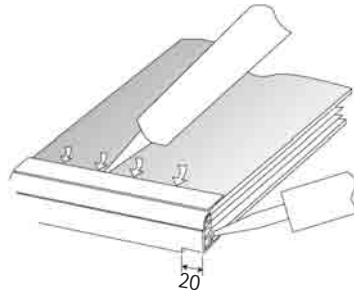

Seal the bottom lip of the closer to the sheet and then seal up the open ends. Clean away any excess sealant.

Ensure the closer is sealed to the panel and not the breather tape!

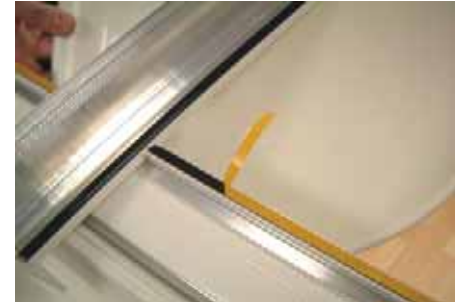

Peel back a start on the support trim security tape so it can be pulled off from the inside when the panel is in position.



Offer the roof panels into position so they are central between the rafters. See the notes above for positioning panels.



With the panel in its final position, remove the film from the security tape on the support trim and press the panel down. If the roof is 10° pitch or lower then run a sealant line between the underside of the roof sheet and the support trim.



With a roof panel in each side of the rafter, knock the rafter top cap down onto the rafter using a rubber headed mallet. Use a piece of timber when knocking on the foiled aluminium top caps to avoid denting the caps.



Jack rafter top caps are supplied over size and will require cutting down on site. Foiled aluminium top caps are supplied with the gasket over-length.



Seal the rafter top cap to ridge rain excluder joint.



Seal the jack to hip rafter top cap joint.



Roof panels at the top of the valley may require the jack rafter to be released to allow the panel to be positioned. This is best done without the panel having the end closer fitted.

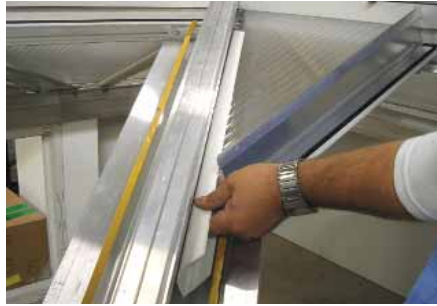

Remove the film off the security tape and press the panel down once in position. Re-connect the jack rafter and then slide the end closer up onto the roof panel as shown.



Push the sealant nozzle under the top lip of the end closer and run a continuous line of sealant to form a gasket.

7.3 Glass roofs



Secure each glass retainer with the 2 screws provided. Transom rafter glass retainers should finish flush with the end of the rafter as shown. **Note:** XGS6 packer within sheet closer.



Please note that the hip rafter glass retainer when pushed up to the roof glass will be fixed shy of the rafter end.



Wedge packers should be used to pack the glass between the rafters, 2 packers per corner are supplied.

1 Larger roofs may come supplied with muntin strip to join units together. Assemble the two units and the muntin strip dry within the roof.

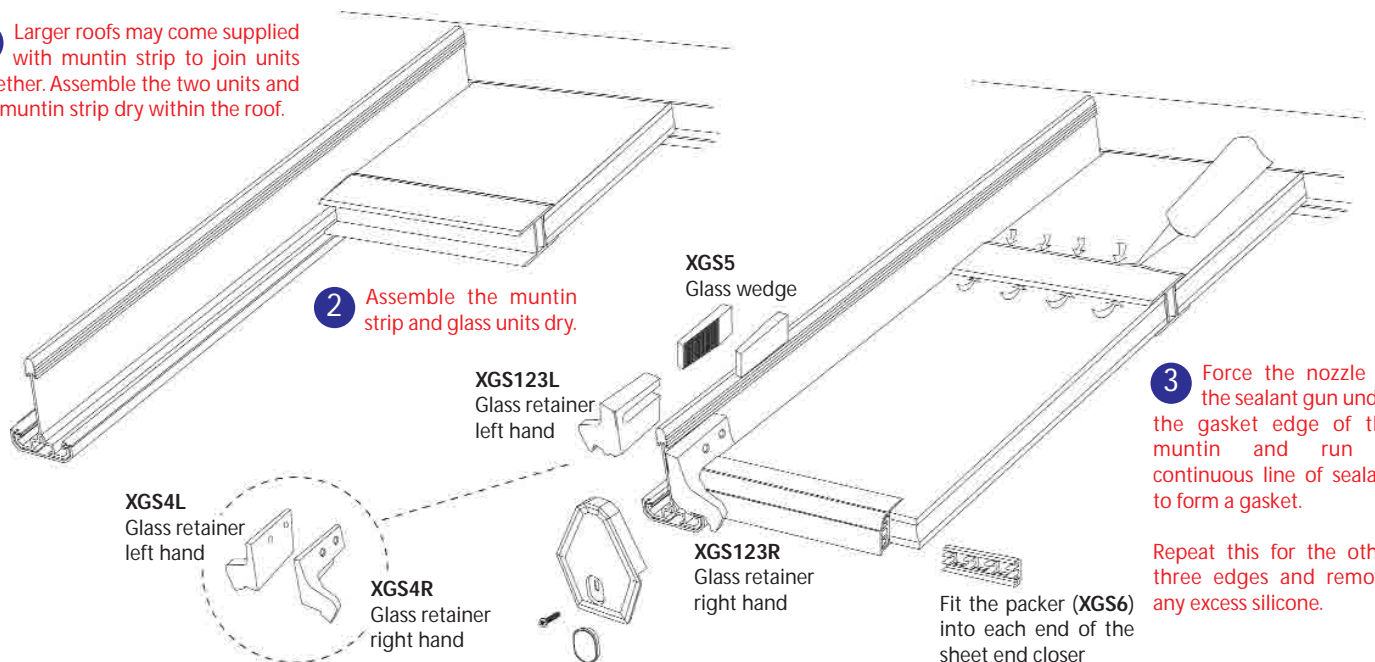

Note: Long span rafters use thinner glass retainers and NO wedges

Glass roofs are supplied with glass kits as shown above. Position the glass and push the glass retainer up to the sheet closer and screw it into position using the XM425 screws provided. Wedge the glass against the retainer using the wedges when provided.

Repeat this for the other three edges and remove any excess silicone. **Secure each glass retainer with 2 No. XM425 screws**



Fully glaze and cap all of the rafters, which fall onto the radius end.



Using a hacksaw blade cut down the width and height of the bridged section of foam bung so that it fits snugly between the rafter top caps and finishes level with the top of the ridge.



Remove the bung and silicone seal around the ridge profile making sure the silicone runs down to the glazing level on both sides.



Insert the cut down section of bung making sure it is pushed firmly in to the silicone seal.



Test fit the half round foam bung making sure the chamfer runs downwards.



If the bung is too large for the aperture, cut two v-notches in to the bung using a hacksaw blade.



Adjust the size of the v-notches depending on the size of the aperture.



Push the bung in to the aperture so it finishes just above the rafter top caps.



Silicone seal the joint between the two foam bungs including the joints between the two v-notches.



Finally run a continuous seal around the foam bung so it is sealed to the glazing and rafter top caps.



Some corner ridges will have a radius end detail. Cut the foam bung components down to fill the void.



Completely seal the rafter top caps and roof sheets to the face of the foam bung. Seal the foam bung to the end profiles of the ridge.

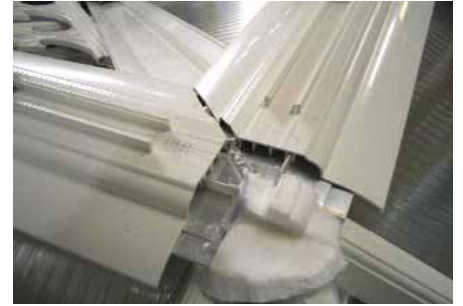

Fit the ridge top caps to the ridge body as per the photo above. Note the removal of the creasting upstands.



Position the ridge top cap corner cover XPT90 and drill 2 No. 5mm holes per side (8 total).



Apply silicone sealant to the ridge top in the area below the XPT90.



Fix the XPT90 into position using the 8 plastic rivets (XREC3) provided. Clean up and remove any excess silicone.

8.3 Ridge 'T' joint

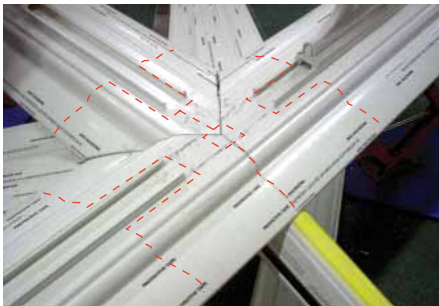

Fit the 3 separate ridge top caps leaving a tight mitred joint. Remove protective tape and apply lines of sealant as shown in red above. Note that the creasting track has been removed.



Position the 2 covers onto the joint over the lines of sealant. Compress the joint and rivet the covers to the ridge top caps in the 6 positions shown. Use the plastic rivets provided through 5mm diameter holes.



Seal and rivet the rear joint cover to the previous covers completing the joint. Remove excess sealant ensuring the edges of all joint lines are sealed.



The run of crestings can now be slid along the ridge top cap over the joint. The bottom legs on the creasting should have been removed to allow this.



The adjacent line of creasting can now be slid into place over the joint.



The completed assembly.



Centralise the two clips on the ridge top cap with the two bars on the main ridge.



Starting at one end knock the top cap in to position using a rubber mallet.



The top cap is in its correct position when the wings of the top cap touch the wings of the main ridge.

Refer to Section 9.2 for fitting the aluminium ridge top cap

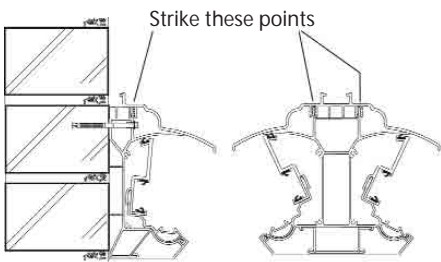

Make sure the correct position is struck when fitting the top caps. In colder weather conditions a block of timber can be used to spread the impact over the PVC-U top cap.



The PVC-U wallplate top cap is exactly half of a ridge top cap and is fastened in the same manner.

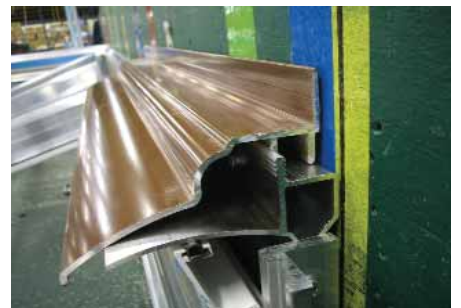

The painted aluminium wallplate top caps do not clip onto the wallplate but are held in place with plugs and screws.



An extrusion line has been incorporated along the back upstand of the aluminium wallplate top cap for the positioning of the fixing screws.

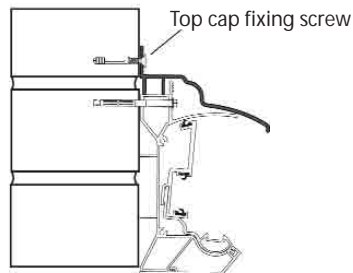

Picture showing the positions of the wallplate fastening and the top cap fixing screw.



Bay and hip-ended lean to roofs require a radius end top cap. This should be sealed and secured to the wallplate top cap with the plastic rivets supplied.

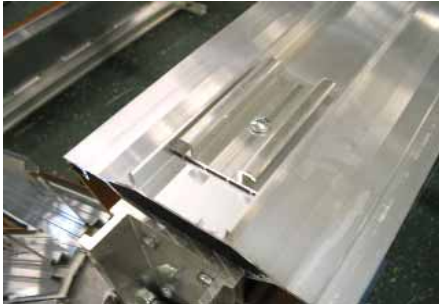

The painted aluminium ridge top caps are attached to the ridge using clips (XR4), which are pre-fitted to the main ridge during manufacture.



First prepare the ridge for the fitting of the ridge flashing trim (XFT1). Place the flashing trim over the wall end of the ridge top cap and mark where its front edge finishes.

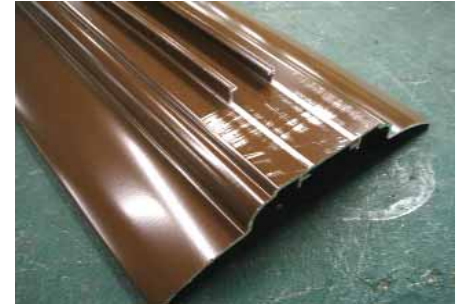

Using a hacksaw cut back the crestring upstands up to the mark line making sure they are cut level with the surface of the top cap.



Run two continuous beads of sealant over the ridge top cap where the crestring bars were removed.



Fit the flashing trim and fasten using the supplied push fit rivets through a 5mm drilled hole.



Slide the ridge top cap onto the ridge.

Note: Slide the ridge top cap onto the ridge before the fitting of the hip rafter top caps. Always check the roof design to make sure the top cap can be fitted without restriction.

9.3 Radius end top cap



The radius or gable end of the ridge top cap will have been notched during manufacture. Cut off the crestring bars so that they finish level with the notch depth. File this area flat.



Run two beads of silicon over the ridge top cap.

Note: The foam bung will need to be fitted prior to the fastening of the radius end top cap.



Fit the radius end top cap and fasten using the push fit rivets through 5mm drilled holes.

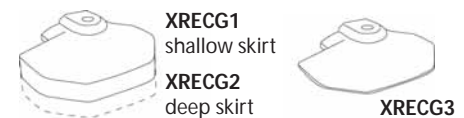

Certain roofs will be supplied with blank radius end top caps that require the skirt notching around the rafters. A non-skirted version is available as an extra if required.

Certain roofs will have the radius end top cap pre-notched.



Supplied when no centre rafter and roof pitch is 25° on all sides. Supplied when there is a centre rafter and roof pitch is 25° on all sides.



Slide the crestring over the radius end top cap into the crestring channel. The length of the last crestring may require shortening to fit behind the finial point.



Finally insert the finial by turning it in to the screw port in the radius end top cap.



Assembly Guide

9.4 Gable end top cap



Fit the ridge top cap so that the pre-notched crestring channel faces to the front and finishes 50mm back from the front of the ridge.



Remove the first section of crestring. Run two continuous lines of sealant over the full width of the ridge top cap.



Fit the gable end top cap. Drill through the two caps using a 5mm drill and fix in place with the supplied push rivets.

Note: Do not use screws to fix cap, use rivets.



The last crestring length may require shortening to fit behind the finial point. Slide the crestring over the gable end cap into the crestring channel.



Screw the finial in to gable end top cap.

9.5 Ridge top cap joint



The ridge top caps are joined via the plastic joiner. Centre the joiner over the joint and mark the crestring upstands each side.



Cut away the crestring upstands and file the ridge top cap smooth in this area.



Silicone seal the ridge top cap butt joint in the area below the joiner.

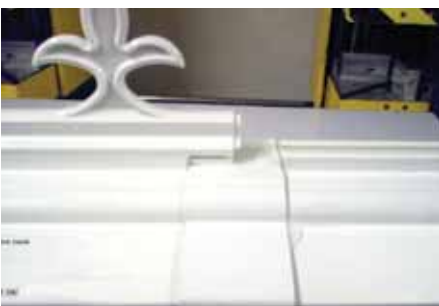

Place the joiner over the siliconed joint and slide the crestings back into place.



Drill 2 No. 5mm holes each side of the joiner and fit the rivets supplied.



Repeat the process for the other edge on the joint.

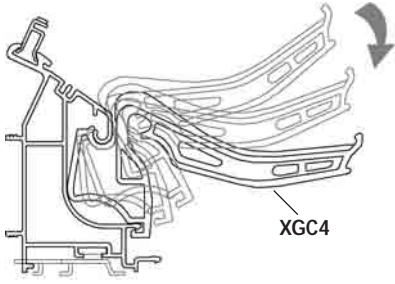

Position the top of the gutter bracket (XGC4) in to the eaves beam monkey tail. Rotate the bracket downwards until the bottom of the bracket clips in to the eaves beam clip. A Nylon or rubber mallet can be used to locate the clips if required.



Position the brackets at a maximum of 600mm centres and a maximum of 150mm in from each end of the eaves beam.



Position the main gutter so that the monkey tail clip faces outwards. Push the back of the main gutter (XYGUT2) up in to the gutter bracket clip (XGC4). Continue this procedure until the back of the main gutter is installed in to all of the gutter brackets.



Pull up and clip the front of the gutter bracket in to the main gutter monkey tail.



Next fit the gutter corner unions, this is made easier by lifting up the front of main gutter.

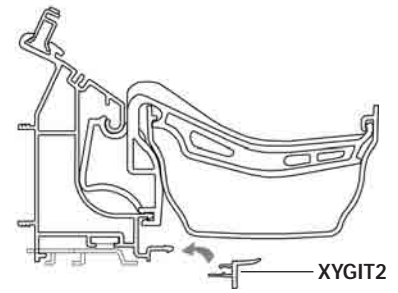

The gap between the bottom of the gutter and the top of the frames is cloaked off with an under gutter trim (XYGIT2).



The gutter under trim is sent oversize. Measure and cut the trim so that it fits between the gutter unions, stop ends or both.



An injection moulded trim will be supplied to fit under the angled gutter unions. These have been designed for 90° and 135° gutter unions.



These are installed by pushing them up in to place under the gutter union.



When a running outlet or stop end are used a straight under gutter trim (XUGT180) will be supplied. This will require marking and cutting to length.



Remove the screw lug off the end of any gutter union that fits on to a box gutter adaptor.



On straight unions the support webs will also need to be removed on the back and bottom sides.



Slide the union over the adapter making sure the union gasket remains in situ.



The box gutter end cap can now be installed. On some roof designs this may need trimming to suit.



The end cap is then fitted by pushing it in to the end of the box gutter.



Finish off by fitting the main gutter and under gutter trims.

11.1 Internal eaves cladding



Eaves Beam: Seal all of the internal corner joints.



Place an internal eaves clad joint on to the end of an internal eaves clad. Position the clad over the eaves beam so that its clips line up with the eaves cladding barbs. Knock the cladding on using a rubber mallet.



Slide the next section of eaves clad in to the eaves clad joint and knock the eaves clad in to position as before. Carry on with this procedure until all of the eaves clads are fitted.



11.2 Internal ridge cladding



Ridges: Prior to fitting check the length of the ridge under clad by measuring the distance of the ridge up to the radius end bottom cap, which can be fitted first. Place the ridge under cladding on to the bottom of the ridge and clip it in to position using a rubber or nylon hammer.



The radius end bottom cap is either fitted by clipping it on to the radius end or using a nut and bolt. This will depend on the type of radius end used. When the large radius bottom cap is supplied it is fixed with a nut and bolt.



The quarter radius end bottom cap is fitted with a nut and bolt. Fit this prior to fitting the ridge under clads.



Typical detail showing the intersection of multiple ridges. These under clads will be cut to suit during manufacture.

11.3 Internal valley cladding



Valley: Fit the internal eaves beam clads and eaves clad joint.



Fit the ridge bottom caps. Each internal valley wing clad will be cut oversize and will require trimming. Fit the top of the clad up to the ridge bottom caps.



Trim the bottom of the valley clad so it fits up to the internal eaves beam clads. Attach the valley clad in the same manner as the internal eaves clads.



Repeat the process to fit the second valley bottom clad.



Picture showing how a valley finishes against an in-line gable frame. The valley wing clad, which fits against the gable will need to be trimmed to suit.



Box Gutter: Position then knock the box gutter under clad in to position using a rubber mallet.



Fit the box gutter side clads in the same manner as the internal eaves beam clads.



How the box gutter should look once it is fully cladded.



Raised Leg Box Gutter: Fit all of the internal side clads as standard.



Extra box gutter under clad is supplied to cloak of the remaining raised leg section.



Measure and cut each individual section out of the extra under clad. This will clip down in to the already fitted side clad. The top will need to be fixed to the raised leg section with double sided tape or gunnable glue (not supplied).



A flexible corner fillet is supplied to cover the corner of the raised leg section this is fixed with double sided tape (not supplied).

11.5 Internal wallplate cladding



Wallplate Bottom Cap: Position the bottom cap making sure the bottom clip fits over the wallplates bottom barb. Using a rubber mallet knock the front bottom cap clip on to the wallplate in a continuous run from one end.



The internal half radius end cover is connected using the nut, bolt and bolt cap provided.



The internal half radius end cover should be scribed to fit around the wallplate.

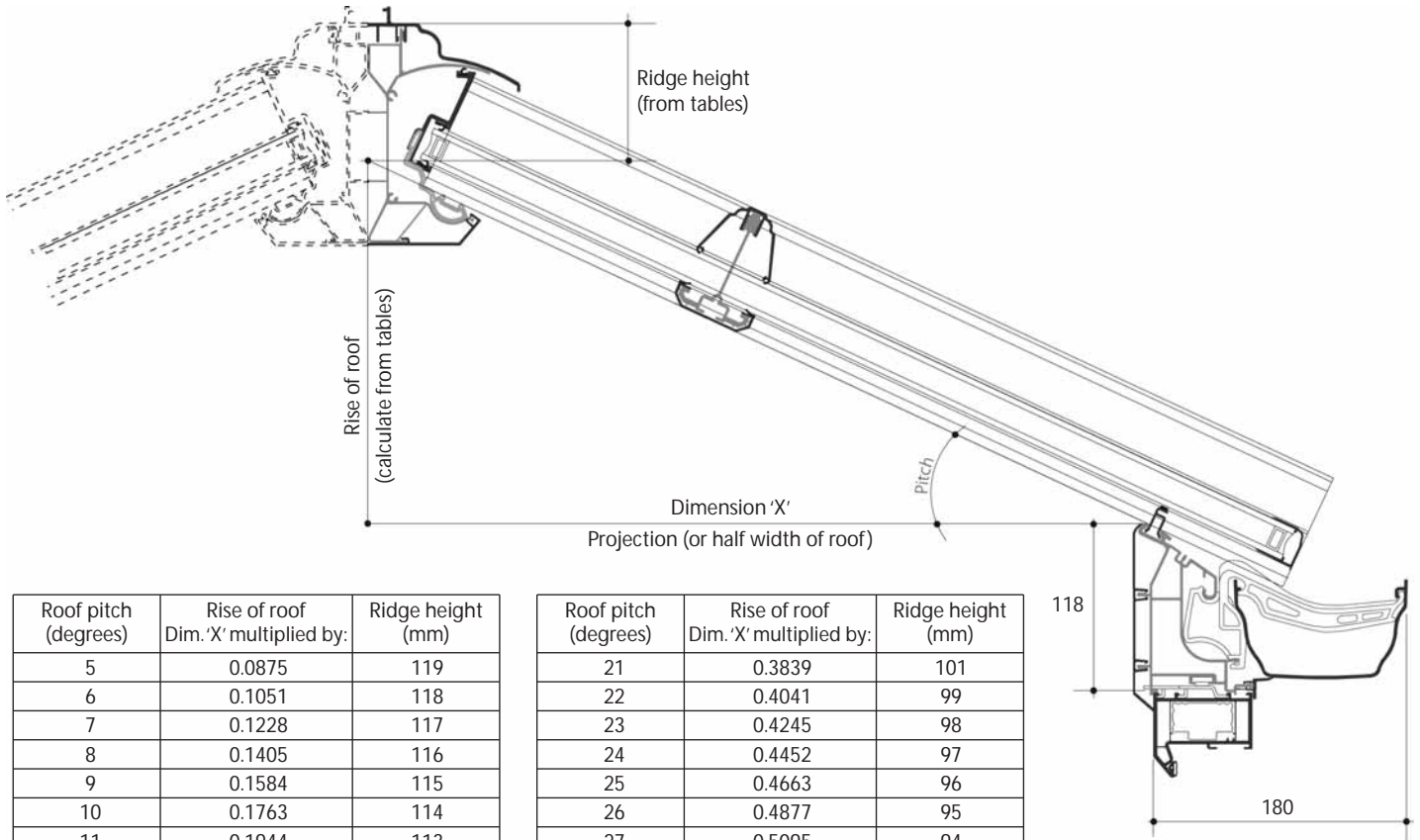

Roof pitch (degrees)	Rise of roof Dim. 'X' multiplied by:	Ridge height (mm)
5	0.0875	119
6	0.1051	118
7	0.1228	117
8	0.1405	116
9	0.1584	115
10	0.1763	114
11	0.1944	113
12	0.2125	112
13	0.2309	111
14	0.2493	110
15	0.2679	109
16	0.2867	108
17	0.3057	107
18	0.3249	106
19	0.3443	104
20	0.3639	102

Roof pitch (degrees)	Rise of roof Dim. 'X' multiplied by:	Ridge height (mm)
21	0.3839	101
22	0.4041	99
23	0.4245	98
24	0.4452	97
25	0.4663	96
26	0.4877	95
27	0.5095	94
28	0.5317	92
29	0.5543	90
30	0.5773	88
31	0.6009	87
32	0.6249	86
33	0.6494	85
34	0.6745	84
35	0.7002	82

25mm rafters

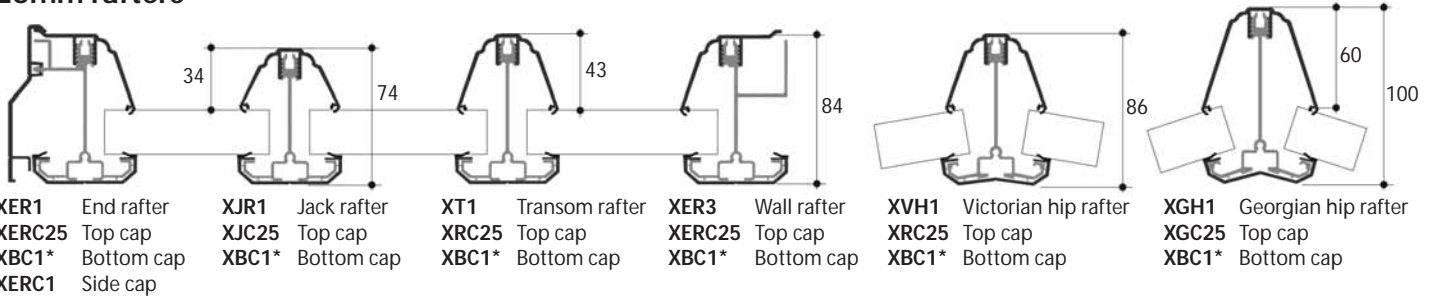

35mm rafters

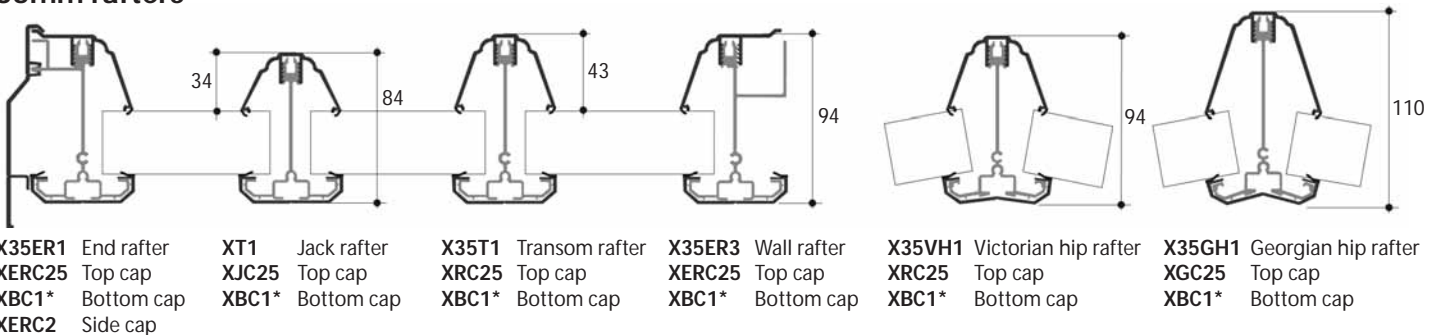

*XBC1 for Shield Roofs, XBC3 for Global Roofs



SYNSEAL EXTRUSIONS LIMITED, COMMON ROAD, HUTHWAITE, SUTTON-IN-ASHFIELD, NOTTS. NG17 6AD

TEL: (01623) 443200 FAX: (01623) 443305

www.synseal.co.uk

Shield & global are Synseal products