



# **BATTERY ISOLATOR XS**



## CONTENTS

<b>INTRODUCTION</b>	<b>PAGE 1</b>
<b>SPECIFICATION</b>	<b>PAGE 2</b>
<b>SAFETY NOTES</b>	<b>PAGE 3</b>
<b>INSTALLATION</b>	
<b>FITTING</b>	<b>PAGE 4</b>
<b>SWITCH CONNECTIONS</b>	<b>PAGE 5</b>
<b>ENGINE KILL CONNECTION</b>	<b>PAGE 6</b>
<b>FINAL CONNECTION</b>	<b>PAGE 7</b>
<b>MULTILINGUAL WIRING DIAGRAMS</b>	<b>PAGE 8</b>
<b>FAULT DIAGNOSIS</b>	<b>PAGE 9</b>

## CONTACT INFORMATION

### ***CARTEK AUTOMOTIVE ELECTRONICS LTD***

Unit 25, Mitchell Point  
Ensign Way, Hamble  
Southampton  
SO31 4RF  
UNITED KINGDOM

**+44(0)2380 457747**

**info@cartekmotorsport.com**

**www.CARTEKMOTORSPORT.com**

## INTRODUCTION



### INTRODUCTION

The **CARTEK Battery Isolator XS** is a fully electronic 'master/kill switch' system designed specifically for race car applications. This device contains no moving parts and the solid construction provides very high resistance to shock, vibration, water and dirt. Using the latest MOSFET technology this Battery Isolator provides safe, spark-free isolation of the vehicle's battery and engine electrics.

**Meets FiA safety regulations.**

### PRINCIPLE OF OPERATION

All race and rally master switches must perform two functions, (1) disconnect the battery from all electrical circuits and (2) kill the engine. The Battery Isolator XS performs the battery disconnection function by breaking the connection between the NEGATIVE battery terminal and CHASSIS/EARTH. The Battery Isolator XS performs the engine kill function by outputting a signal which can be used to enable/disable ECUs or PDMs or used to control an engine relay.

**Alternator run-down protection is incorporated.**

The electronic isolation circuits are controlled by a microprocessor and incorporate various safety systems including over-temperature and over-current monitoring. The microprocessor also monitors the kill switches/buttons for instant activation while eliminating false triggering. The unit will therefore instantly trigger into isolation mode when any of the kill buttons are struck or on detection of any break in switch wiring circuits such as during an accident.

**The Isolator also incorporates an LED which displays status as well as fault codes.**

**CARTEK Battery Isolators are designed for SAFETY and RELIABILITY.**

## SPECIFICATION

### Typical installation

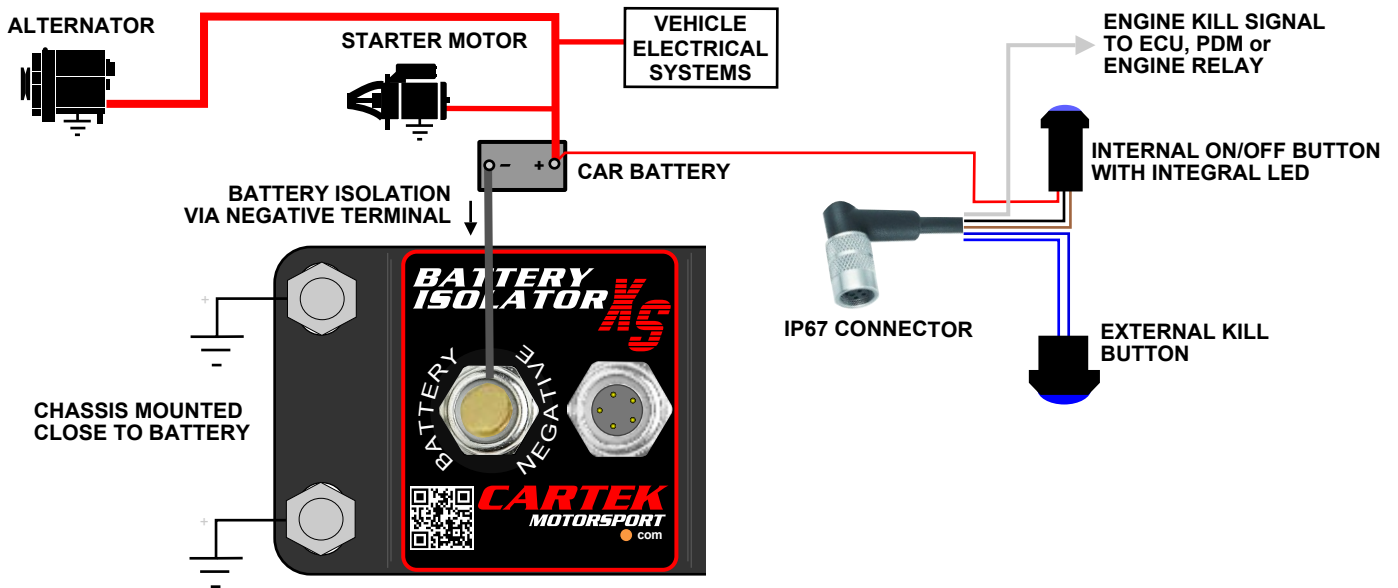

### Technical Details

Size:	L = 60mm, W = 45mm.
Weight:	70g.
Battery negative terminal:	M8 stud.
Electrical Connector:	Binder 09 0415 90 05
Connection cable (supplied):	Binder 79 1456 272 05 (2 meter long)
Operational Voltage:	7v - 18v
Current consumption:	25mA ON, 0mA OFF
Battery negative switching current:	600A cranking, 2000A surge
Engine signal kill current:	12v 0.5A when ON, switched to chassis/earth when OFF
Operating temperature:	-10°C - +85°C.
Storage temperature:	-40°C - +125°C

## SAFETY NOTES

- Please read through the Instructions thoroughly before installing on your race car. If not installed correctly then damage may occur to the Battery Isolator.
- The Battery Isolator must be fully connected before starting the engine. If the engine kill output signal is not connected when the engine is running then damage to the Battery Isolator may occur. (Cars without alternators do not apply).
- Do not use the **CARTEK** Internal Button for any other application, it is designed specifically for use with **CARTEK** Battery Isolators only.
- The Battery Isolator must be removed if any electric welding is being carried out on the car.
- When using a Battery Charger or an external starter/booster battery then it is important to connect both terminals directly to the car battery. **DO NOT CONNECT THE NEGATIVE LEAD OF THE CHARGER OR EXTERNAL BATTERY TO THE CHASSIS. THIS MAY CAUSE DAMAGE TO THE BATTERY ISOLATOR.**

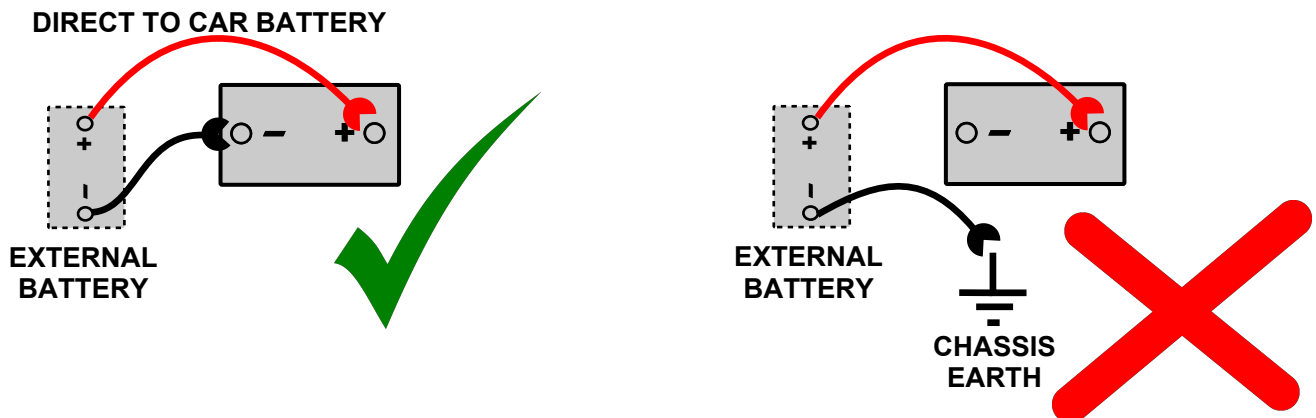

**MOTORSPORT IS DANGEROUS.  
THIS PRODUCT IS DESIGNED FOR MOTORSPORT USE ONLY AND SHOULD NOT  
BE USED ON ROAD/STREET VEHICLES OR ON PUBLIC HIGHWAYS.  
NO WARRANTY IS MADE OR IMPLIED REGARDING ANY CARTEK PRODUCTS TO  
PROTECT USERS FROM INJURY OR DEATH.  
USER ASSUMES ALL RISKS.**

## INSTALLATION

### Step 2. FITTING

The Battery Isolator should be mounted directly to the vehicle's metal chassis close to the vehicle's battery but away from any high temperature sources.

The Battery Isolator should be mounted securely with unpainted screws/bolts to provide good electrical contact with the chassis.

If mounting directly to a metal chassis is not possible then an 'earth' cable can be used to connect the metal casing of the Battery Isolator to a suitable point on the chassis or engine block.



ADDITIONAL  
EARTH CABLES

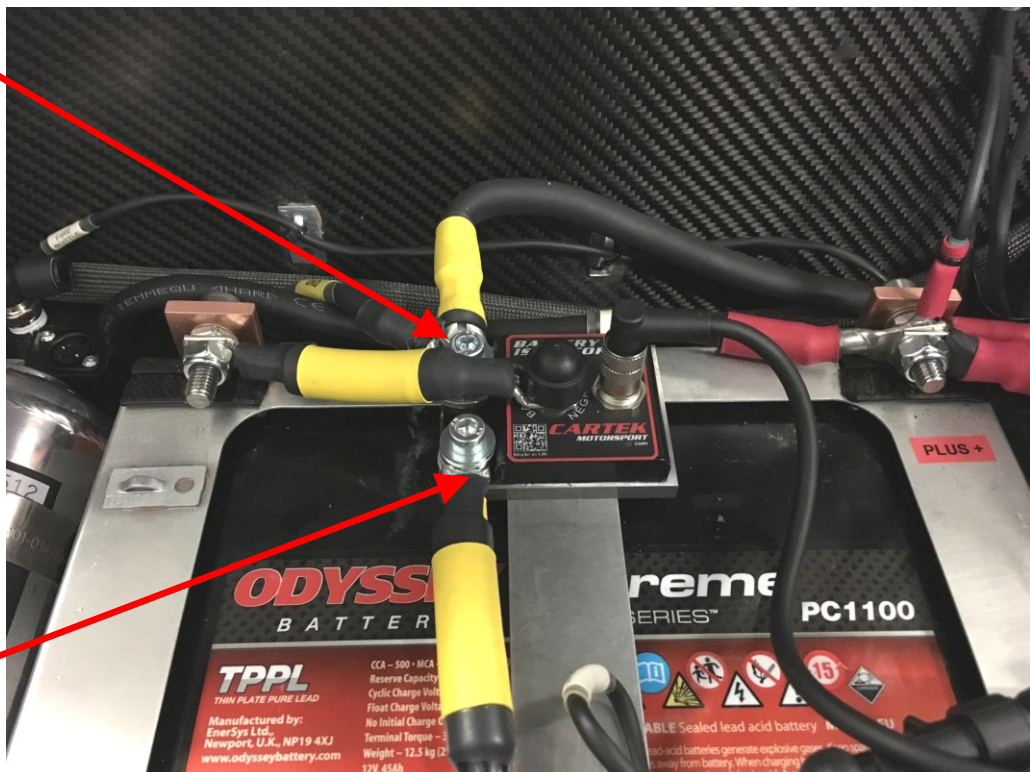

ADDITIONAL  
EARTH CABLES



## INSTALLATION

### Step 2. SWITCH CONNECTIONS

The Isolator can be controlled by any number of on-off/kill switches although the usual configuration is one internal on-off button and one external kill button.

The internal switch needs to be of a latching type, either toggle or pushbutton, such that the ON position makes the circuit while the OFF position breaks the circuit.

The external kill switch should be of the non-latching, momentary action, normally-closed (NC) type and connected between the Blue and Grey wires of the external switch circuit. If required, multiple kill switches/devices can be incorporated by connecting in series. If only a single internal on-off switch is to be used with no external switch then the external circuit needs to be complete by joining the Grey and Blue wires together. If any wire connection becomes broken due to fatigue or accident then the Battery Isolator will automatically switch OFF killing the engine and disconnecting the battery.

**WARNING: Do not test the Internal Button by passing power through it, this will damage it. It will only work correctly when connected to the Battery Isolator.**

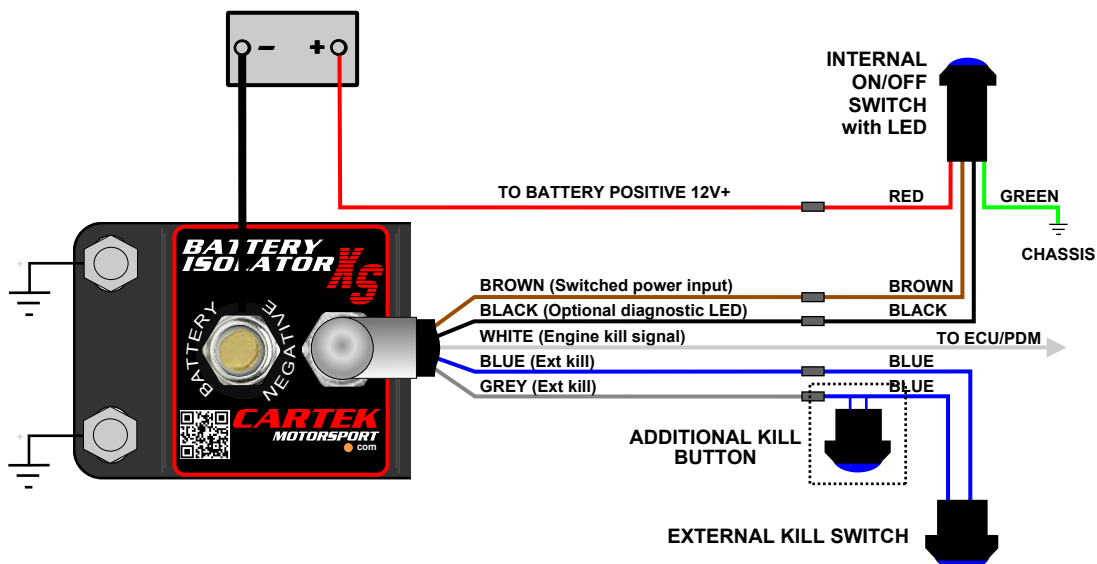

**CARTEK** Battery Isolators allow for an external 'kill' button to be mounted on both sides of a race car for instant access and maximum safety.



## INSTALLATION

### Step 3. ENGINE KILL CONNECTION

For cars equipped with an alternator, the Battery Isolator needs to kill the engine by sending a signal to the engine ECU or electronic Power Distribution Module (PDM) or by shutting down the main engine relay.

The engine kill output signal has two states:

Battery Isolator ON - 12V (0.5A max).

Battery Isolator OFF - 0V(Earth).

Make sure the ECU or PDM is able to accept this type of Engine Kill Signal. Most OEM ECUs will not be able to accept this type of signal while most programmable Motorsport ECUs and PDMs will.

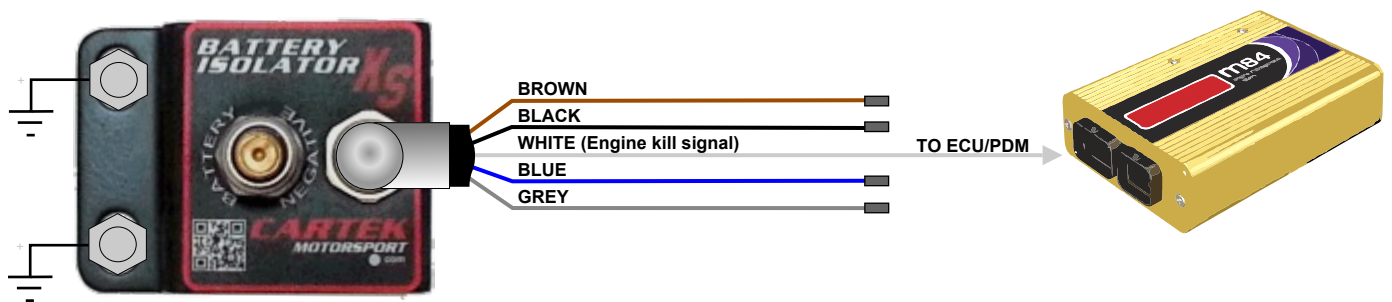

It is also possible to use the Engine Kill Signal to control an Engine Relay/DME. Please check the manufacturers specification before installing.

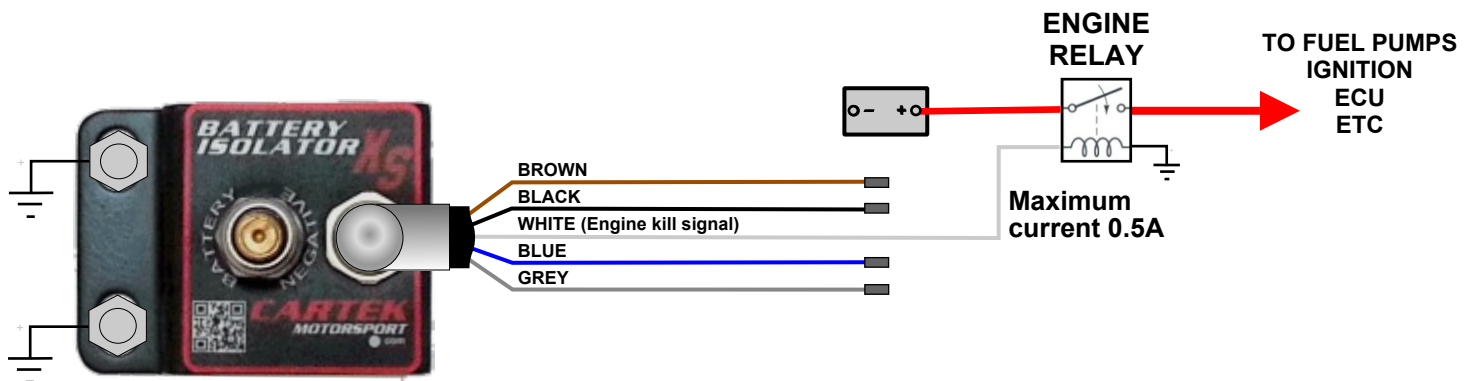

**WARNING: The Battery Isolator must be fully connected before starting the engine. If the engine kill output signal is not connected when the engine is running then damage to the Battery Isolator may occur. (Cars without alternators do not apply).**



### INSTALLATION

#### Step 4. FINAL CONNECTION

Once Steps 1,2 & 3 are completed a final connection should be made from the negative terminal of the vehicle battery to the Battery Isolator terminal marked BATTERY NEGATIVE. This connection should be made with cable of 100-200Amp capacity and by keeping as short as possible will offer maximum weight saving of the complete installation.

Once this final step is complete please check all connections before switching on.

*When fitting or removing the Isolator always connect the battery last and disconnect first.*

**Here is an example of a completed installation:**

**BATTERY NEGATIVE CONNECTION**

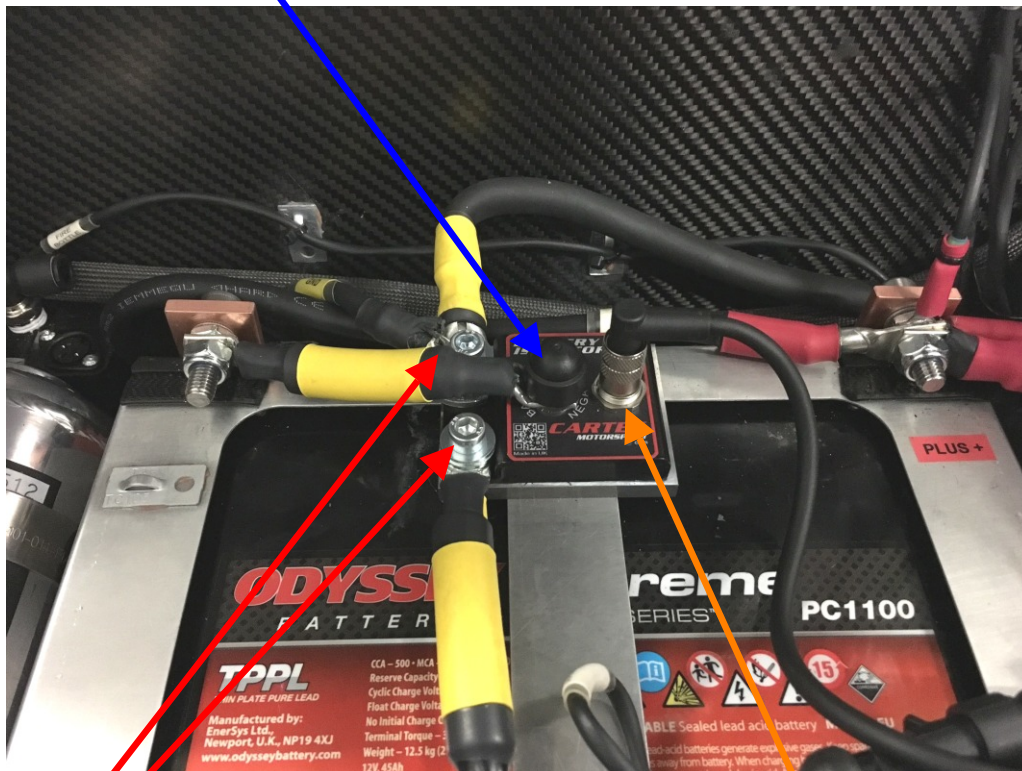

**ADDITIONAL EARTH CABLES  
WHEN NOT MOUNTED DIRECTLY  
TO CHASSIS**

**Wired up to: Internal Button  
External Button  
ECU/PDM/Engine Relay**

### INSTALLATION - MULTILINGUAL

(GB) Installation diagram    (IT) Collegamenti per installazione    (ES) Conexiones de instalación

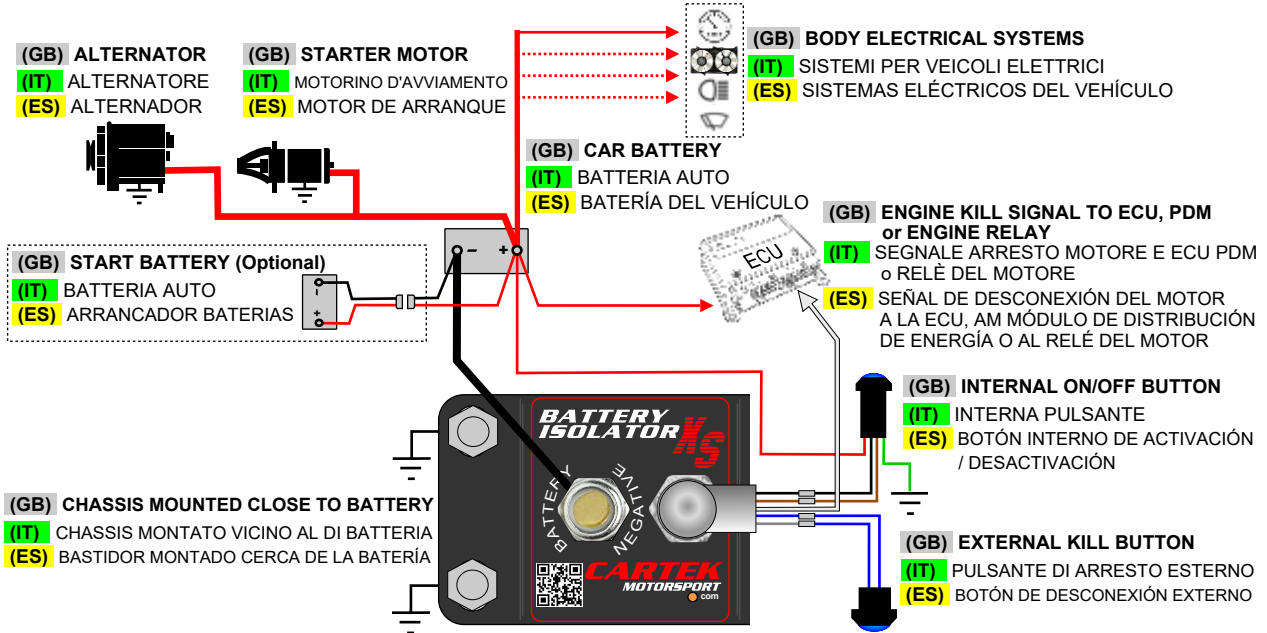

(GB) Installation diagram    (FR) Installation des connexions    (DE) Installationsanschlüsse

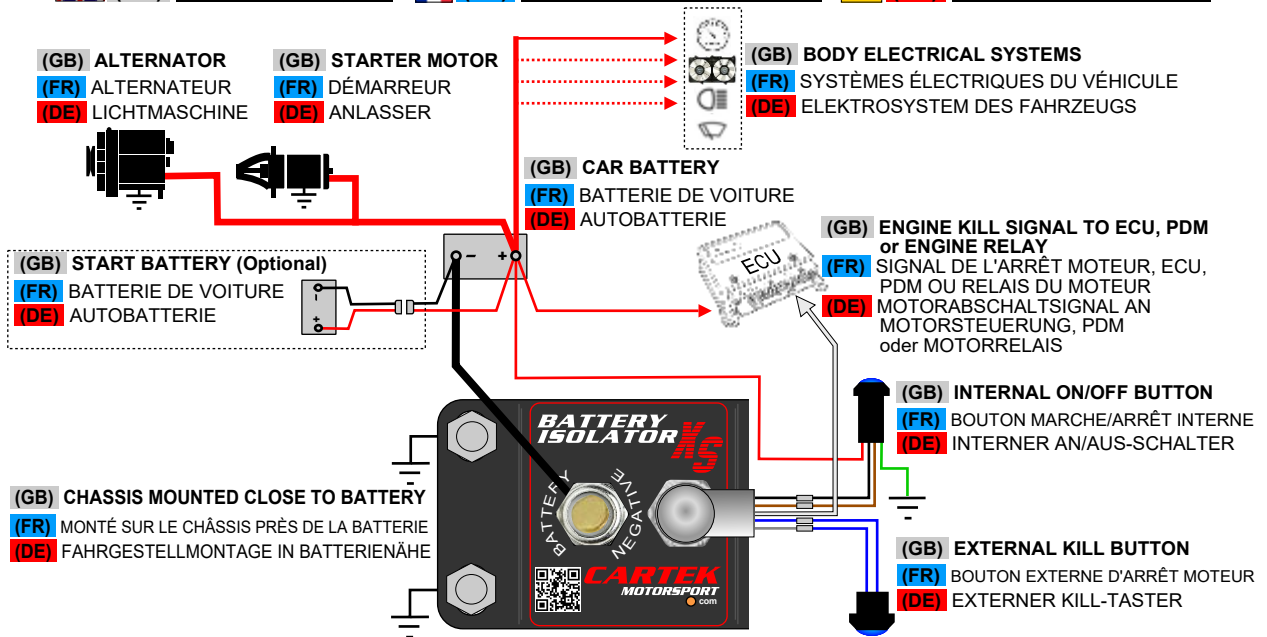



## FAULT DIAGNOSIS

Once fully installed, the Isolator is switched ON by activating the internal ON-OFF switch/button. On activation the Isolator performs a system check before electrical power is switched on. If any fault is detected then the Isolator will remain in the OFF state and display the fault status via the LED in a sequence of flashes:

**1 flash - External kill button pressed or circuit broken.**

*If the External Kill Button has not been activated then check the wiring between the Battery Isolator and the button. One way to confirm a fault with this wiring is to join the Grey and Blue wires together close to the Battery Isolator thereby bypassing the external kill button and associated wiring.*

**2 flashes - Maximum temperature exceeded.**

*The Battery Isolator will automatically switch OFF if maximum temperature is exceeded. This may occur after very prolonged engine cranking or if the Battery Isolator is mounted close to a source of heat e.g. engine, coolant pipes, exhaust, radiator fan, etc.*

**8 flashes - Maximum current in NEGATIVE circuit exceeded.**

*Check for a short circuit from battery positive to chassis such as faulty Alternator or Starter Motor.*

Once the fault is remedied the Isolator can be reset by switching OFF the internal switch/button then switching ON again. The unit will also be fully reset by disconnecting from the vehicle battery and reconnecting.

### Causes of Errors

1. Make sure there is only one cable attached to the negative terminal of the battery and that this cable connects to the Battery Isolator and nowhere else. There must be no cable between the negative terminal of the battery and chassis.
2. If the Battery Isolator does not switch ON when the internal button is pressed to the ON position then observe any flashing LED error code and identify the fault from the list above. If the Battery Isolator does not switch ON and does not display any error code then check the connections between battery and Battery Isolator and make sure the battery is fully charged.