

**NORTHGATE**  
TAKING CARE OF EVERY ASPECT



# SUBRA FIRE & SECURITY

**NORTHGATE**  
TAKING CARE OF EVERY ASPECT

Northgate, PO Box 200, Barnet, Herts EN4 9EW  
**Tel** 020 8441 4545 **Fax** 020 8441 4888  
**Website** [www.northgateuk.com](http://www.northgateuk.com) **Email** [enquiries@northgateuk.com](mailto:enquiries@northgateuk.com)



## SUBRA FIRE & SECURITY

High security commercial and service sites, up to 50m<sup>2</sup>, with 1-hour fire-rating to stop spread of fire through an opening. The Steelroll FS60 tested at Exova Warringtonfire under BS EN 1634-1:2008 test conditions, and assessed to BS EN 476-22:1987, is designed to contain fire within particular parts of a building. In the event of a fire alarm, the shutter automatically descends by operation of the motor. Further failsafe devices to ensure higher levels of response to a fire outbreak or alarm.

### Curtain Slat

Single Skin 76mm Curved Steel. Standard galvanised finish. Wall thickness 0.7mm, 0.9mm, or 1.2mm, depending on overall shutter opening width. Colours: Galvanised finish as standard. Plastisol range or powder coating available.

Visible Surface: 76mm  
 Profile Height: 86.6mm  
 Weight per m<sup>2</sup>: 10kg - 16kg  
 Maximum Width: 12,000mm  
 Maximum Surface: 10m<sup>2</sup> with single phase power or 50m<sup>2</sup> with 3-phase power.

### Enclosure/Housing

Manufactured from 0.9mm galvanised steel sheet. End caps are fabricated from 5mm+ steel. A barrel support frame at the centre of the housing may be required in some applications.

Colours: Galvanised finish as standard. Plastisol range or powder coating available. Note: The enclosure heights are based on standard tube motor operation or In Line external chain drive motor. In Line motor applications enclosure projection sizes will vary dependent on the overall size.

### Shutter Height (mm):

2500  
 4000  
 5500

### Box Size (mm):

305  
 355  
 400

### Guide Channels/Bottom Slat:

Galvanised steel sectioned with strengthened T-shape bottom bar. Guide channel depth will vary dependent on application from 65mm to 100mm. Colours: Galvanised finish as standard. Plastisol range or powder coating available. Note: The guide channels are bolted to fixing angles or steel box sections dependent on the application. See drawings on this sheet.

Profile view

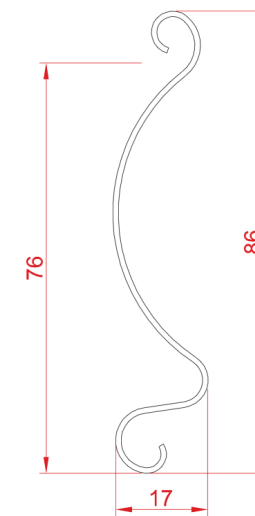

Front Face View

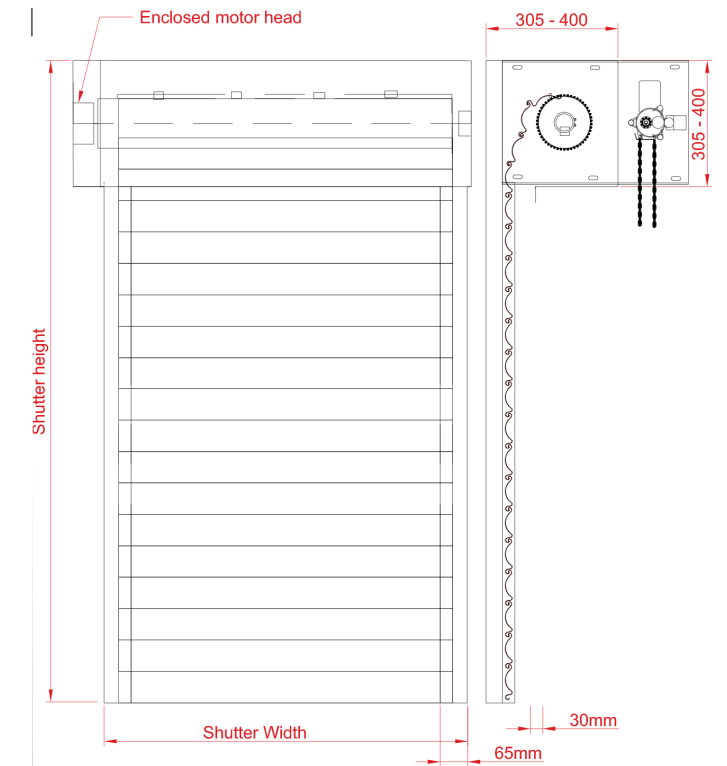

Guide options

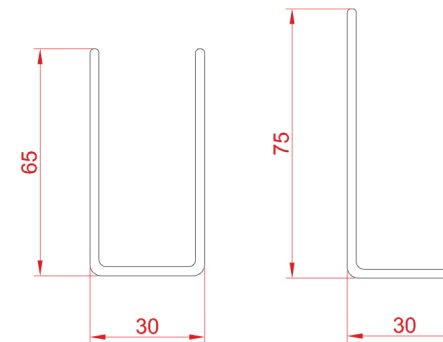

Fixing options

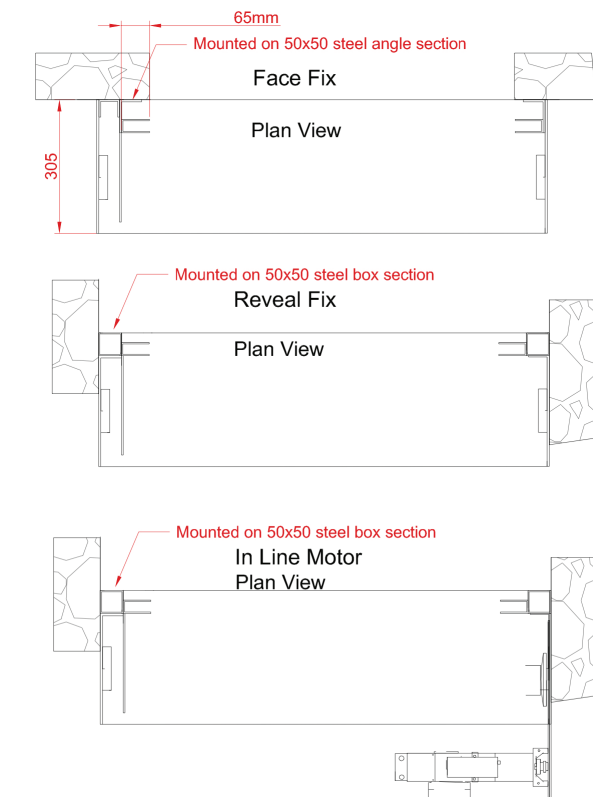

For more information and images please visit our website at:

[WWW.NORTHGATEUK.COM/PRODUCT/SUBRA-FIRE-SECURITY/](http://WWW.NORTHGATEUK.COM/PRODUCT/SUBRA-FIRE-SECURITY/)