

1.SAFETY INSTRUCTIONS

Read these instructions carefully. Failure to follow these instructions can result in severe personal injury.



Eye injury hazard

Failure to wear safety glasses with side shields can result in severe eye injury or blindness.



Operation

Tool must not be used by persons not properly trained in their use. Before tensioning strap, read and understand the tool operating instructions. Failure to follow the operating instructions or improper load positioning could result in strap breakage.

Become familiar with your tool and keep fingers away from areas that can pinch or cut.

Joints

You are fully responsible to review the joints made by your tool. Become familiar with the seal control and seal adjustment described in this operation manual. Misformed joints may not secure the load and could cause serious injury. Never handle or ship any load with improperly formed joints.

Dispensing Strap

Only dispense strap from a dispenser specifically designed for strap.

Tuck strap end back into dispenser when not in use.

Protective gloves

When handling strap, always wear protective gloves.



Strap warnings

Never use strap as a means of pulling or lifting loads. Failure to follow these warnings can result in severe personal injury.

Strap breakage hazard

Improper operation of the tool, excessive tensioning, using strap not recommended for this tool or sharp corners on the load can result in a sudden loss of strap tension or in strap breakage during tensioning, which could result in the following:

- A sudden loss of balance causing you to fall.
- Both tool and strap flying violently towards your face.

Note as follows:

- If the load corners are sharp, use edge protectors.
- Place the strap correctly around a properly positioned load.
- Positioning yourself in-line with the strap, during tensioning and sealing, can result in severe personal injury from flying strap or tool. When tensioning or sealing, position yourself to one side of the strap and keep all bystanders away.
- Use the correct strap quality, strap width, strap gauge and strap tensile strength recommended in this manual for your tool. Using strap not recommended for this tool can result in strap breakage during tensioning.

Cutting tensioned strap

When cutting strapping, use the proper strapping cutter and keep other personnel and yourself at a safe distance from the strap. Always stand to side of the strap, away from the direction the loosened strap end will fly. Use only cutters designed for strap and never hammers, pliers, hacksaws, axes, etc.

Fall hazard

Keep your working area tidy. Untidiness of your working area may cause a risk of injury. Maintaining improper footing and / or balance when operating the tool can cause you to fall. Before tensioning and especially in elevated areas, always establish good balance. Both feet should be securely placed on a flat, solid surface, especially when working in elevated areas. Do not use the tool when you are in an awkward position.

Pay attention to the rules and regulations for preventions of accident which are valid for the work place.

Tool hazards

A well maintained tool is a safe tool!

Check tool regularly for broken or worn parts. Do not operate a tool with broken or worn parts.

Never modify any tool. Modification can result in severe bodily injury.

2.WARRANTY CONDITIONS AND LIABILITY

All the packing tools and main products are guaranteed for good repair.

Wearing and Tearing Parts : 3 months since you bought.

Whole Machine: 6 months since you bought.

Any damage to the machine or personal injury resulted from the improper use or happened when the machine is not in use is not the company's responsibility. Company has no obligation to compensate.

The warranty excludes:

- Wearing parts
- Deficiencies resulting from improper installing, incorrect handling and maintaining the tool
- Deficiencies resulting from using the tool without or with defective security-and safety devices
- Disregard of directions in the operation manual
- Arbitrary modifications of the tool
- Deficient control of wearing parts
- Deficient repair works of the tool
- Non appropriate use of the tool

▲ Company reserve the right to modify the product at any time in order to improve its quality.

3. TECHNICAL DATA

Dimensions without suspension bracket

	Tool	Package
Length:	387m/15.2"	410mm/16.1"
Width:	162mm/6.4"	360mm/14.2"
Height:	308mm/12.1"	170mm/6.7"
Weight:	3.9kg/8.6lbs	1.2 kg/2.7lbs

Joint strength

Approx. 80% of the strap's tensile strength.

Steel strapping

Width:	13-19mm(See chart of types)
Thickness:	0.38-0.58mm/0.015" -0.023"
Quality:	<p>Fundamentally the A333 allows the use of all current steel straps with tensile strengths ranging from 700 to 850N/mm²/100 000-123 000 psi.</p> <p>Straps with a low breaking elongation are unsuitable.</p>

4. CHART OF TYPES A333

Model	Strap width	Strap thickness
A333-13	13.0mm	0.38-0.58mm/0.015-0.023"
A333-16	16.0mm/5/8"	0.38-0.58mm/0.015-0.023"
A333-19	19.0mm/3/4"	0.38-0.58mm/0.015-0.023"

5. OPERATION



When use the machine, it's indispensable to wear protection gloves and safety glasses.



Feeding the strapping around the package

The strapping is fed around the package in the direction as shown in the illustration. The strapping end is held tightly with the left hand and pulled firmly towards the operator with the right hand.

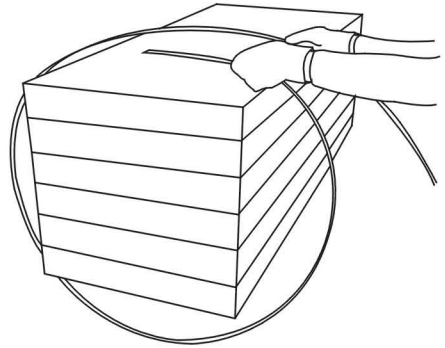

Loading the strapping

The rocker is raised with the right hand. The left hand inserts the two straps lying precisely upon another into the tool until they hit strap stops.

The lower strap end must slightly protrude the end of the base plate.

Be certain that the strapping is held by the strap guide.

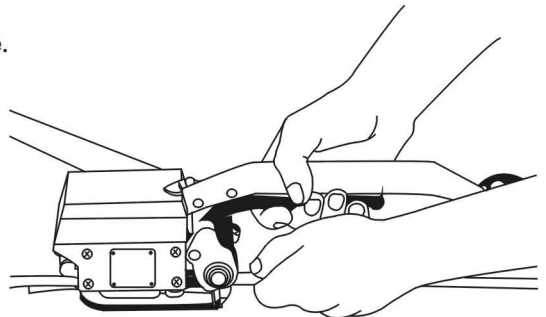

Tensioning the strapping

The tool is held tightly with the left hand being placed on the sealing lever. The tensioning handle is now moved forward and backward with the right hand until the desired tension is attained.

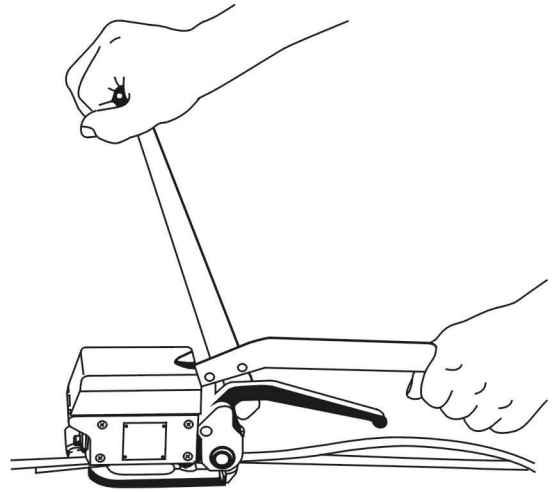

Sealing the strapping

The sealing lever is moved forward using the left hand until it hits the stop. The lever is then moved back to its initial position. When sealing, the right hand absorbs the sealing force by holding the tensioning handle.

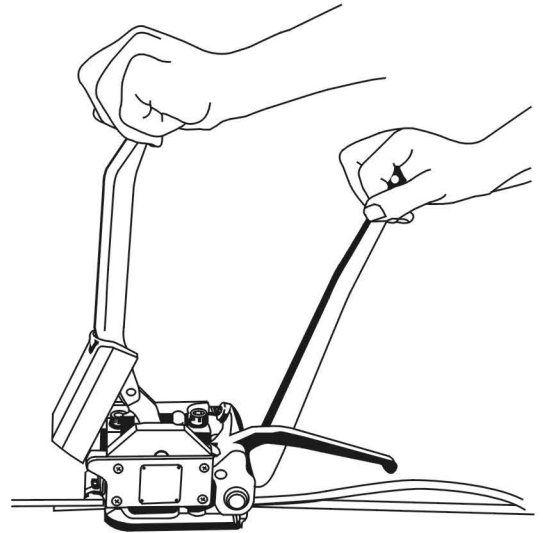

Releasing the tool

Hold the cut off strap end with the left hand, lift the rocker with the right hand and push the tool from the applied strap to the right.

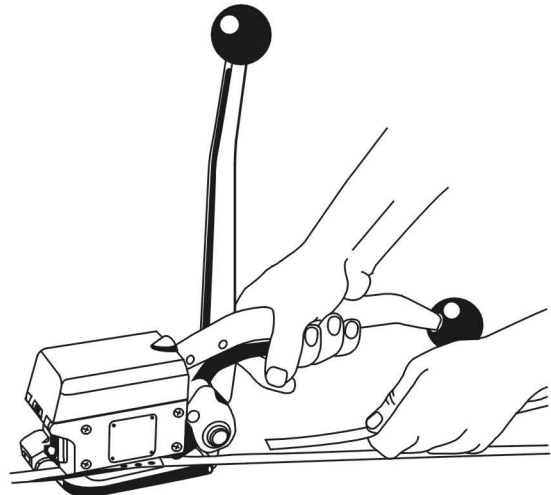

6.SPARE PARTS LIST

Ref. No.	Description	Part No.	Dimension	Pcs.
1	HOUSING	A01		1
2	BASE PLATE	A02		1
3	DIE AND CUTTER SUPPORT	A03		1
4	SEALING CAM	A04		1
5	ROCKER	A05		1
6	SEALING HANDLE	A06		1
7	TENSION HANDLE	A07		1
8	LOCKING RING	A08		1
9	DRIVER	A09		1
10	EJECTOR	A10		1
11	STRAP STOP	A11		1
12	STOP	A12		1
13	TENSION SHAFT	A13		1
14	TENSIONING WHEEL	A14		1
15	GRIPPER	A15		1
16	LINK	A16		1
17	STRAP GUIDE	A17		1
18	ROLLER	A18		1
19	PUNCH	A19		1
20	DIE HALF	A20		1
21	DIE HALF	A21		1
22	SHEAR BLADE	A22		1
23	LIMIT BOLT	A23		1
24	PARALLEL PIN	A24		1
25	PARALLEL PIN	A25		1
26	PARALLEL PIN	A26		1
27	PARALLEL PIN	A27		2
28	PARALLEL PIN	A28		1
29	PARALLEL PIN	A29	Φ 4x25	2
30	PARALLEL PIN	A30	Φ 3x10	1
31	PARALLEL PIN	A31	Φ 4x9	2
32	WOODRUFF KEY	A32		1
33	CHTCH PAWL	A33		3
34	TENSIONING PAWL	A34		3
35	SPACER RING	A35		1
36	WASHER	A36		1
37	WASHER	A37		1
38	WASHER	A38		1
39	WASHER	A39		1
40	BUSH	A40		1
41	CUP SPRING	A41		1

6.SPARE PARTS LIST

Ref. No.	Description	Part No.	Dimension	Pcs.
42	RING HALF	A42		2
43	SHIM	A43		3
44	COVER	A44		1
45	COVER	A45		1
46	TRUNNION	A46		1
47	TORSION SPRING	A47		1
48	PRESSURE SPRING	A48		1
49	PRESSURE SPRING	A49		6
50	PRESSURE SPRING	A50		1
51	GRIP BALL	A51		2
52	DOWEL PIN	A52	Φ 3x10	1
53	GROOVED PIN	A53	Φ 4x14	1
54	DOWEL PIN	A54	Φ 4x20	2
55	GROOVED PIN	A55	Φ 6x14	1
56	DOWEL PIN	A56	Φ 6x20	2
57	SCREW	A57	M10x80	1
58	SCREW	A58	M12x80	1
59	HAMMER HEAD BOLT	A59	Φ 5x10	1
60	HEXAGON NUT	A60	M5	1
61	SLIDE-BEARING	A61	1415	4
62	NEEDLE BUSH	A62	HK1512	1
63	NEEDLE BEARING	A63	HK2012	1
64	SECURITY RING	A64	Φ 15	1
65	SECURITY RING	A65	Φ 20	1
66	HEXAGON NUT	A66	M6	1
67	SOCKET SET SCREW	A67	M4x5	1
68	SOCKET SET SCREW	A68	M5x6	1
69	SOCKET SET SCREW	A69	M5x10	2
70	SOCKET SET SCREW	A70	M12x12	1
71	SCREW	A71	M3x8	2
72	SCREW	A72	M5x16	2
73	SCREW	A73	M6x25	1
74	SCREW	A74	M5x8	1
75	SCREW	A75	M5x12	2
76	SOCKET SET SCREW	A76	M5x32	1
77	SCREW	A77	M8x10	1
78	SCREW	A78	M8x20	1
79	SCREW	A79	M4x10	4
80	SCREW	A80	M4x10	4
81	WASHER	A81	Φ 5.3x Φ 9.3x1	2
82	LABEL	A82		1
83	HAMMER HEAD BOLT	A83		2

7. SEAL CONTROL

A regular control of the seal is necessary. The seal can be checked visually and the person controlling can easily judge the quality of the seal. When checking the seal the following illustrations must be compared.

Correct seal

A correct seal must be conform to the illustration. This means that the depth with which the upper strap hooks into the lower one must be 1-1,5 mm in min. and 2 mm in max.. The upper strap must be sheared clean and the cutter must not leave scratch marks on the lower strap.

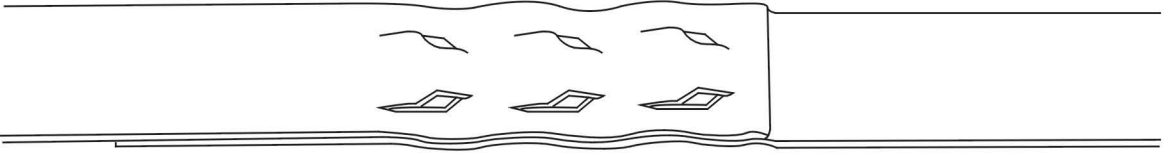

Incorrect seal (the sealing mechanism is adjusted too high)

This stamped seal is not deep enough and the upper strap is not sheared. The tensile strength of this seal is insufficient and the strapping must be taken away from the package. The tool must be readjusted immediately (see SEAL ADJUSTMENT).

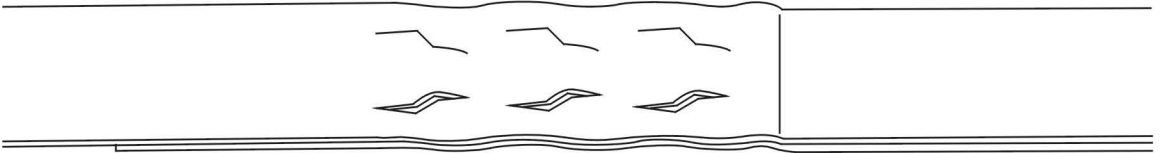

Incorrect seal (the sealing mechanism is adjusted too low)

This stamped seal is too deep and the lower strap is scratched by the cutter. Although the tensile strength of this seal is sufficient the strapping must be taken away from the package because of the scratched lower strap. The tool must be readjusted immediately (see SEAL ADJUSTMENT).

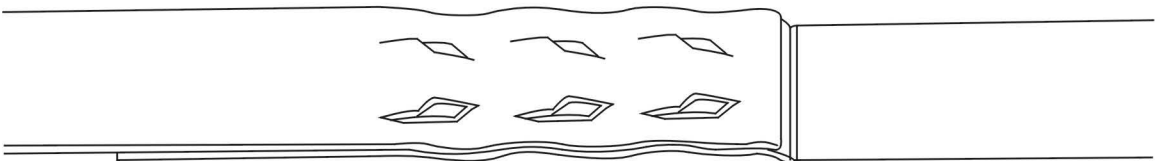

8. SEAL ADJUSTMENT

The sealing and cutting depth of the sealing mechanism and the cutter can be adjusted with the use of the hexagon key A83 which is supplied with the tool as follows:

- Place tool as shown above.
- Loosen both screws A72 open them by approx. 3 revolutions.
- If sealing depth is not sufficient reset stop in the direction of the base plate.
- If sealing depth is excessive reset stop in the direction of the body cover.
- Retighten screws A72.

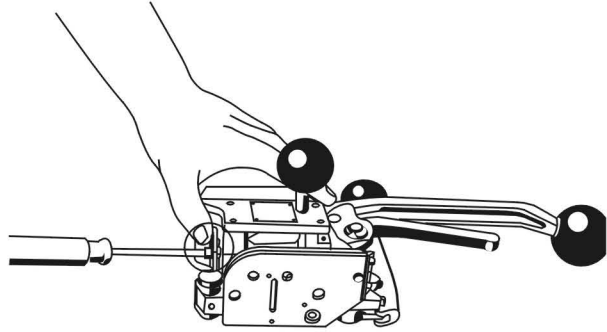

Assembly Instructions

After every disassembly it is essential to retighten screws A57 and A58 with the recommended torque when reassembling. The use of a torque key is necessary.

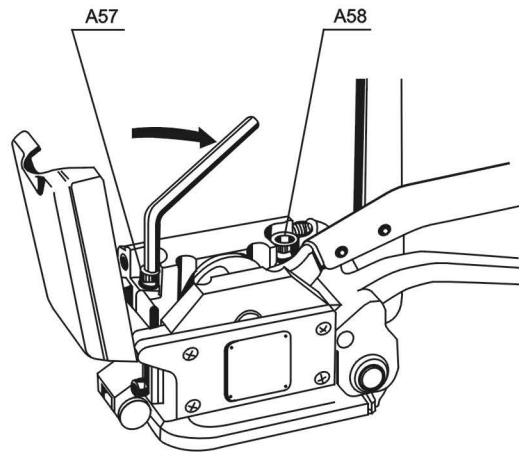

9. CLEANING

In case of heavy dirt and when painted straps are used the punch, dies, gripper and feed-wheel must be cleaned regularly.

Normally it is sufficient to blow out the parts with the help of an air gun.

11.ACCESSORIES

Using tool with horizontal handle

Upon request the tool can be supplied with a bolt A84 and a grip ball A51. When using tool for horizontal applications, the operator holds the tool on the grip ball during tensioning.

Install the handle as follows:

Remove side cover A44 and break the marked position.
Reassemble side cover and screw bolt with mounted ball into the body.

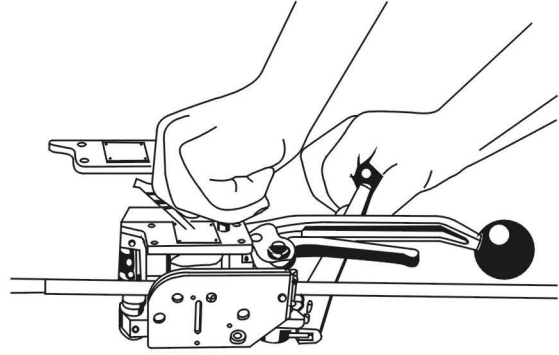

Suspension

It is possible to suspend the tool for strapping in vertical position.
Order the suitable suspension separately under item no. A85.

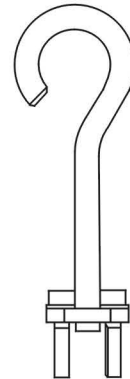

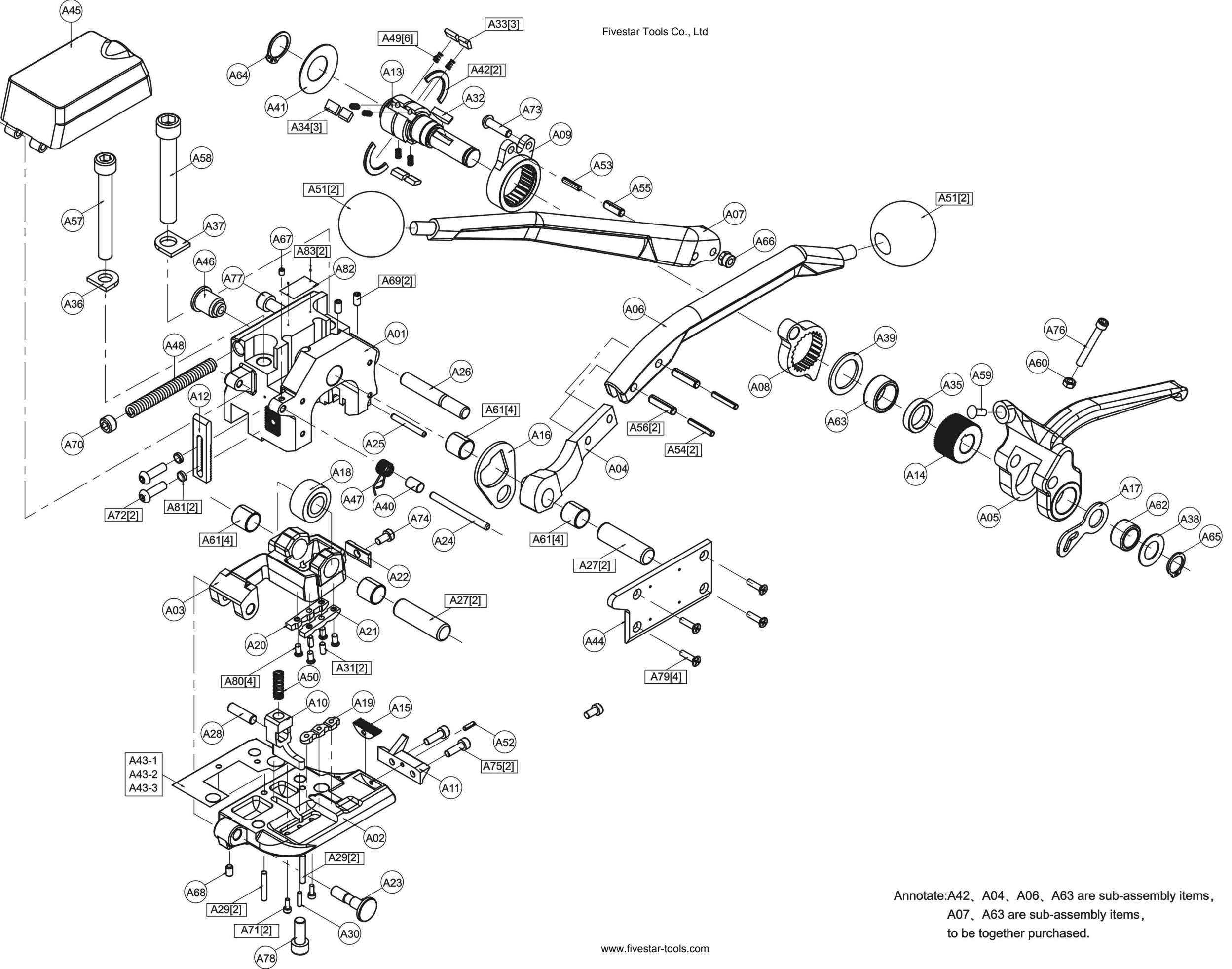

Annotate:A42、A04、A06、A63 are sub-assembly items,
A07、A63 are sub-assembly items,
to be together purchased.