



CHILLED WATER CASSETTE UNITS AC Fan Series

Chilled Water Cassette Units 2/4 Pipe AC Fan Series

UNIT FEATURES

1. Unit Body Casing

Made of galvanized steel and both internal and external surface are thermal acoustic insulated preventing the condensate water and ensuring the silent operation.

2. Water Coil

Manufactured with 3/8" copper tubing mechanically bonded to corrugated hydrophilic aluminium fins. Coils shall be factory tested by dried air to 30 bars. The coil connections are provided with air bleed vent and partial water drain vent. The coil connections are attached with connection supporter.

3. Panel Assembly

An attractive and elegant design ABS panel.

4. Air Delivery Louver

The internal surface is treated by electrostatic fibre and with wave shape, efficiently preventing the condensate water blowing into the room.

5. Air Filter

Installed with the air return grille is moveable and washable.

6. Air Venturi

Equipped with a protective grille that impedes access to the moving fan.

7. External Fresh Air

There is one pre-stamped hole on unit body for introducing outside fresh air going through conditioning coils.

8. Deliver Treated Air To Adjacent Room:

There are pre-stamped holes on unit body for delivery of treated air to the adjacent room.

9. Condensate Drain Device

The unit is equipped with a high density polystyrene foam as main condensate drain pan, a float switch, a no return valve and a pump with 70cm max. head.

10. External Auxiliary Drain Pan (OPTIONAL)

For collecting condensate from the valve piping and transporting it to the main condensate drain pan.

11. Fan Blower & Fan Motor

The balanced centrifugal fan blower and fan motor can be accessed through the window of air return grille, easily for service.

12. The 3-Speed Fan Motor (STANDARD)

The unit is standard equipped with 3 speeds motor

13. Control Box

The control box is attached external of the unit body.

14. Optiona Extras

Electric Heating

Electric Controllers

BMS (ModBus)

Unit Selection Software

15. Main Parts Of The Unit

- 1 Panel assembly
- 2 Unit body
- 3 Mounting bracket
- 4 Air bleed vent
- 5 Water outlet connection
- 6 Water inlet connection
- 7 Water drain vent
- 8 Control box
- 9 Drain pipe connection
- 10 Air delivery louver
- 11 Air return grille
- 12 Lamp board display



FOR ALL YOUR COMMERCIAL APPLICATIONS:

> Shopping Centers > Restaurants > Offices

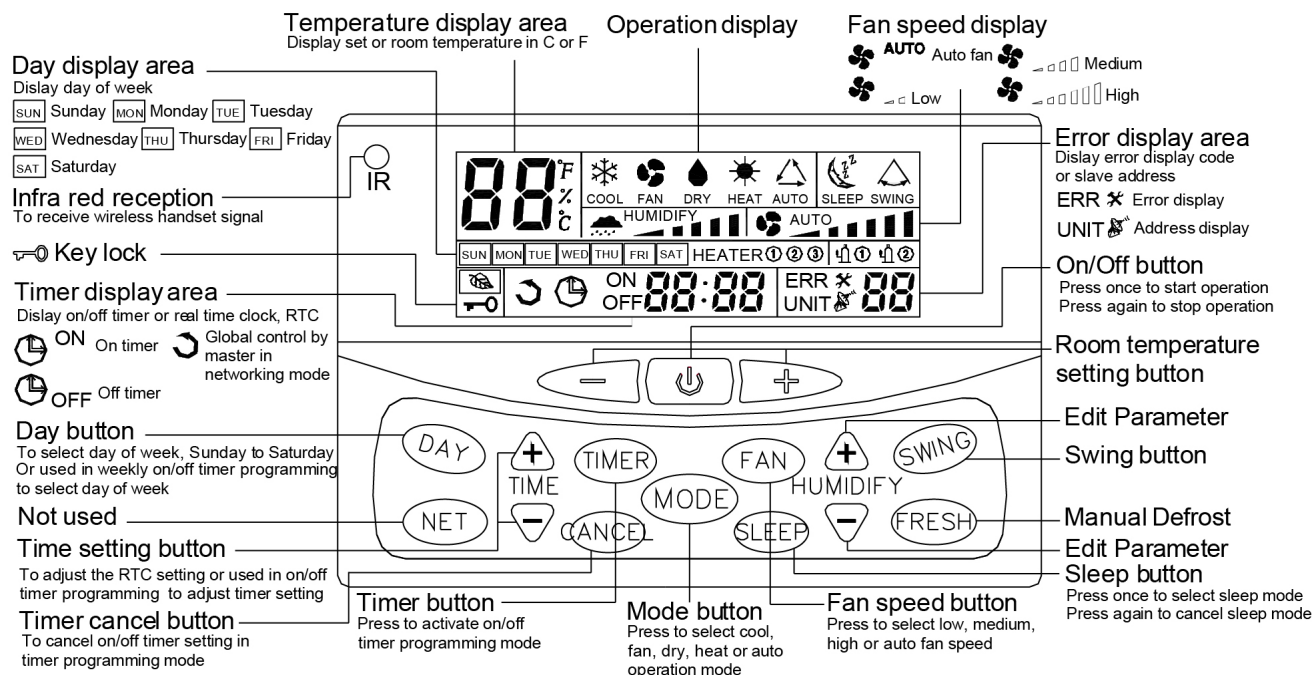

Master / Slave Connection for Multiple Indoor Units (Optional)

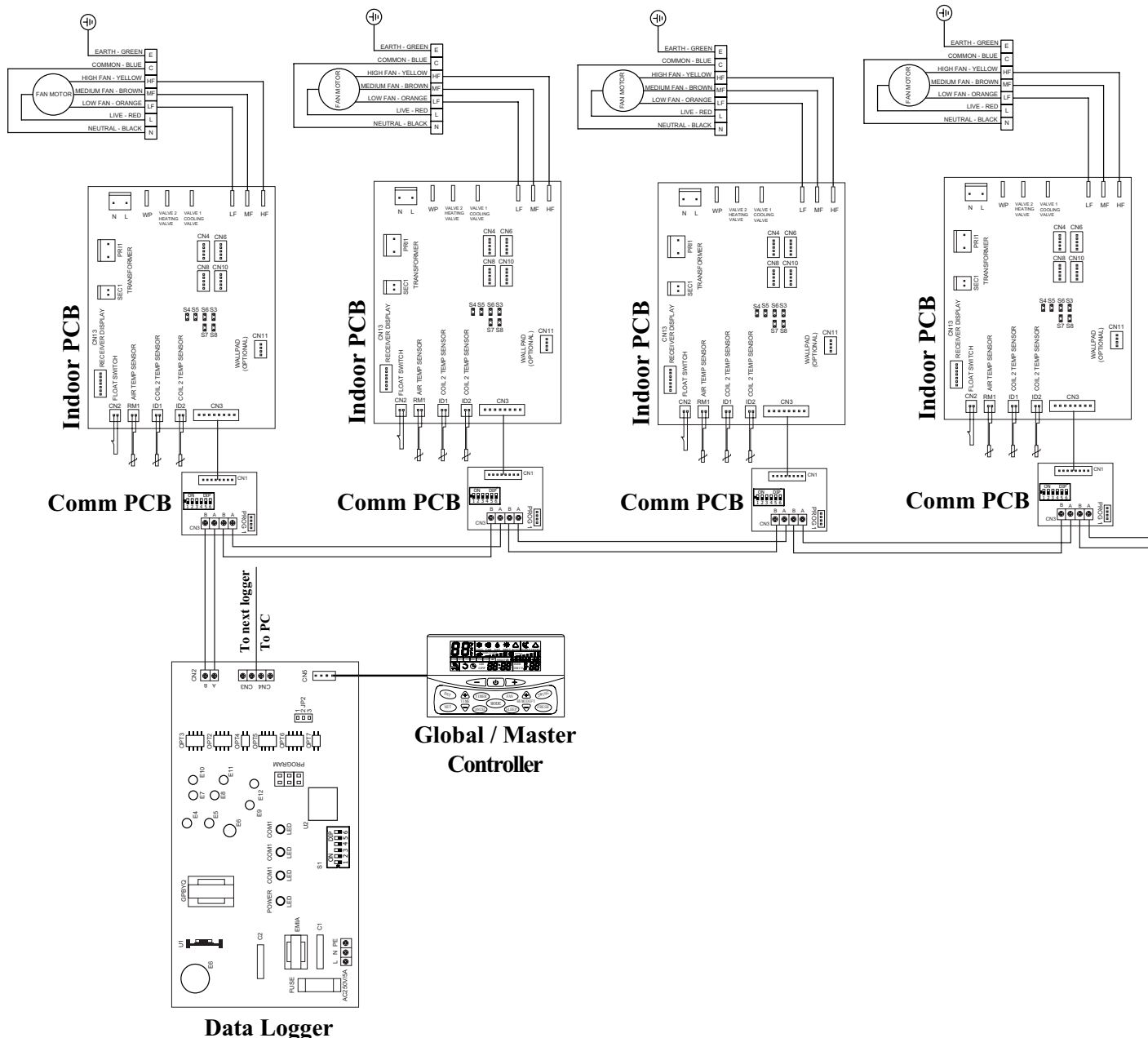

SPECIFICATIONS



CHILLED WATER 4 WAY CASSETTE UNITS 2 PIPE

Model No. Indoor			EC03S-2	EC04S-2	EC06S-2	EC08S-2	EC09X-2	EC10X-2	EC12X-2	EC16X-2	EC20X-2
Power supply			230V / 1PH / 50Hz								
Total Capacity (H / M / L)	Cooling	W	3250 / 2680 / 2280	3530 / 2980 / 2530	4600 / 3940 / 3330	5050 / 4130 / 3440	5740 / 4230 / 3150	6690 / 4830 / 4020	8500 / 5710 / 4190	11100 / 9180 / 7130	18100 / 13900 / 11100
Sensible Capacity (H / M / L)	Cooling	W	2260 / 1850 / 1570	2460 / 2060 / 1750	3220 / 2750 / 2310	3550 / 2890 / 2390	4060 / 2970 / 2190	4750 / 3390 / 2810	6080 / 4030 / 2930	7910 / 6480 / 5000	12900 / 9830 / 7770
Total Capacity (H / M / L)	Heating	W	3020 / 2490 / 2130	3420 / 2890 / 2470	4320 / 3710 / 3140	4750 / 3890 / 3250	5450 / 4030 / 3000	6170 / 4460 / 3720	7840 / 5280 / 3880	9960 / 8220 / 6390	16000 / 12300 / 9760
Electric Heating (OPTIONAL MAX.)		W	2000	2000	2000	2000	2000	2000	3000	3000	3000
Noise Level (1m) (H / M / L)	Indoor	dB(A)	38 / 35 / 30	39 / 36 / 32	42 / 38 / 35	43 / 40 / 36	44 / 41 / 37	45 / 42 / 39	47 / 44 / 41	49 / 46 / 42	57 / 52 / 48
Air Flow (H / M / L) Cooling		l/s	118 / 94.1 / 78.4	130 / 106 / 88.3	176 / 147 / 121	197 / 155 / 125.8	225 / 157 / 112	270 / 183 / 148	360 / 223 / 155	459 / 364 / 270	783 / 568 / 432
Air Flow (H / M / L) Heating		l/s	130 / 104 / 86.8	150 / 124 / 103	197 / 165 / 136	220 / 174 / 141	243 / 171 / 122	292 / 199 / 161	388 / 242 / 169	480 / 382 / 284	809 / 588 / 448
Water Flow Rate (Cooling)		l/s	0.155 / 0.128 / 0.109	0.168 / 0.142 / 0.121	0.219 / 0.188 / 0.159	0.241 / 0.197 / 0.164	0.274 / 0.202 / 0.15	0.319 / 0.23 / 0.191	0.405 / 0.272 / 0.2	0.531 / 0.438 / 0.34	0.866 / 0.664 / 0.528
Water Flow Rate (Heating)		l/s	0.0722 / 0.0596 / 0.0509	0.0818 / 0.0693 / 0.059	0.103 / 0.0889 / 0.0752	0.114 / 0.0932 / 0.0777	0.131 / 0.0963 / 0.0718	0.148 / 0.107 / 0.089	0.188 / 0.126 / 0.0929	0.238 / 0.197 / 0.153	0.383 / 0.294 / 0.233
Water Pressure Drop (Cooling)		kPa	14.4 / 10.3 / 7.86	16.6 / 12.4 / 9.38	26.2 / 20.1 / 15	30.8 / 21.8 / 15.8	11.9 / 7.04 / 4.26	15.5 / 8.82 / 6.44	23.4 / 11.8 / 6.91	30.3 / 21.6 / 14	81.9 / 51.5 / 34.5
Water Pressure Drop (Heating)		kPa	3.20 / 2.31 / .76	3.97 / 2.98 / 2.27	5.94 / 4.58 / 3.44	7.01 / 4.97 / 3.64	11.1 / 6.56 / 3.95	3.41 / 1.95 / 1.43	5.15 / 2.6 / 1.54	6.31 / 4.52 / 2.93	16.6 / 10.5 / 7.02
Fan / Motor	Fan Diameter	mm	315	315	315	315	380	380	380	476	530
	Fan No.	Qty	1	1	1	1	1	1	1	1	1
	Motor No.	Qty	1	1	1	1	1	1	1	1	1
	Power	W	39	54	58	64	71	84	127	170	290
Water Coil	Working Pressure	MPa	1.6								
	Rows	QTY	2								
	Tube Diameter	Inch	3/8"								
Pipe Connections	Water - In	Inch	3/4"								
	Water - Out	Inch	3/4"								
	Drain	Inch	1" (Outer Diameter)								
Unit Dimensions	W x H x D	581 x 581 x 290	581 x 581 x 290	581 x 581 x 290	581 x 581 x 290	701 x 701 x 290	701 x 701 x 290	701 x 701 x 290	701 x 701 x 290	811 x 811 x 290	950 x 950 x 290
Panel Dimensions	W x H x D	680 x 680	680 x 680	680 x 680	680 x 680	830 x 830	830 x 830	830 x 830	830 x 830	980 x 980	1140 x 1140
Weight	kg - Neft	23.5	23.5	23.5	23.5	31	31	31.5	31.5	39.5	52



Unit Selection Software Available - Contact ECO AIRE for more information

SPECIFICATIONS



CHILLED WATER 4 WAY CASSETTE UNITS 4 PIPE

Model No. Indoor			EC06S-4	EC08S-4	EC09X-4	EC10X-4	EC12X-4	EC16X-4	EC20X-4
Power supply			230V / 1PH / 50Hz						
Total Capacity (H / M / L)	Cooling	W	3680 / 3170 / 2680	4030 / 3310 / 2760	5000 / 3700 / 2760	5820 / 4210 / 3500	7380 / 4970 / 3650	9900 / 8180 / 6370	16200 / 12500 / 9970
Sensible Capacity (H / M / L)	Cooling	W	2670 / 2290 / 1920	2940 / 2390 / 1980	3580 / 2620 / 1940	4190 / 2990 / 2480	5340 / 3550 / 2580	7110 / 5840 / 4510	11700 / 8930 / 7070
Total Capacity (H / M / L)	Heating	W	538 / 480 / 423	577 / 496 / 432	795 / 629 / 500	895 / 695 / 602	1080 / 790 / 621	1610 / 1380 / 1130	2570 / 2070 / 1710
Noise Level (1m) (H / M / L)	Indoor	dB(A)	42 / 38 / 35	43 / 40 / 36	44 / 41 / 37	45 / 42 / 39	47 / 44 / 41	49 / 46 / 42	57 / 52 / 48
Air Flow (H / M / L)		l/s	160 / 133 / 109	179 / 141 / 113	209 / 146 / 103	251 / 170 / 136	336 / 207 / 143	439 / 348 / 257	759 / 550 / 417
Cold Water Flow Rate		l/s	0.175 / 0.151 / 0.128	0.192 / 0.158 / 0.132	0.239 / 0.177 / 0.131	0.278 / 0.201 / 0.167	0.352 / 0.237 / 0.174	0.472 / 0.39 / 0.304	0.774 / 0.596 / 0.475
Cold Water Pressure Drop		kPa	3.89 / 3.01 / 2.27	4.54 / 3.25 / 2.39	8.2 / 4.90 / 2.97	10.6 / 6.10 / 4.46	16 / 8.09 / 4.77	21.6 / 15.5 / 10.1	58.9 / 37.3 / 25.1
Hot Water Flow Rate		l/s	0.0129 / 0.0115 / 0.0101	0.0138 / 0.0119 / 0.0103	0.019 / 0.015 / 0.012	0.0214 / 0.0166 / 0.0144	0.0258 / 0.0189 / 0.0149	0.0386 / 0.033 / 0.0270	0.0614 / 0.0496 / 0.0413
Hot Water Pressure Drop		kPa	0.0217 / 0.0194 / 0.0171	0.0233 / 0.02 / 0.0175	0.0408 / 0.032 / 0.0257	0.0459 / 0.0356 / 0.0309	0.0553 / 0.0405 / 0.0319	0.216 / 0.166 / 0.0786	0.554 / 0.384 / 0.281
Fan / Motor	Fan Diameter	mm	315	315	380	380	380	476	530
	Fan No.	Qty	1	1	1	1	1	1	1
	Motor No.	Qty	1	1	1	1	1	1	1
	Power	W	58	64	71	84	127	170	290
Water Coil	Working Pressure	MPa	1.6						
	Rows	QTY	2						
	Tube Diameter	Inch	3/8"						
Pipe Connections	Water - In	Inch	3/4"						
	Water - Out	Inch	3/4"						
	Drain	Inch	1" (Outer Diameter)						
Unit Dimensions	W x H x D	581 x 581 x 290	581 x 581 x 290	701 x 701 x 290	701 x 701 x 290	701 x 701 x 290	811 x 811 x 290	950 x 950 x 290	
Panel Dimensions	W x H x D	680 x 680	680 x 680	830 x 830	830 x 830	830 x 830	980 x 980	1140 x 1140	
Weight	kg - Neff	23	23	30	30	30	38	50	



Unit Selection Software Available - Contact ECO AIRE for more information

ECOAIRE REFERENCES

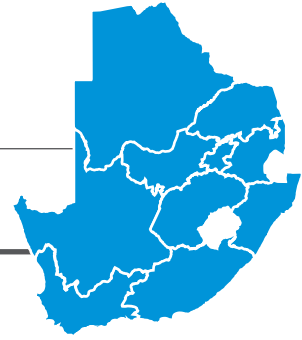

SHOPPING MALLS



V & A Marina Waterfront
Mall of the North
Soshanguve Crossing
The Grove
Mall @ Middelburg
Northgate Mall
Cradlestone
Mall of the South
Watercrest Mall
Thaba Mall
Canary Walk – Nelspruit
Waterstone – Cape Town
Zevenwacht Mall

HOTELS & ENTERTAINMENT



Westcliff
– Johannesburg
Gold Reef City Casino
– Johannesburg
Grand West Casino
– Cape Town
Emperor's Palace
One & Only
– Cape Town
Tusk Casino
– Empangeni
Radisson Hotel
– Port Elizabeth

EDUCATIONAL



Westville University
UNISA Florida
University of Pretoria
Engineering Department -
Thuto Building -
Mangosuthu Technikon
University of Johannesburg:
Bunter Road

HOSPITALS



3 Military Hospital
Panorama Mediclinic
Civitas Pretoria
Natalspuit Hospital
Netcare Pinehaven
Highveld Eye Hospital
Military Health Base
Mokopane Hospital
Albert Luthuli Academic
Hospital
Addington Hospital
Vryburg Hospital
N1 City Hospital

PUBLIC BUILDINGS



Alice Lane Offices
Choose Life Church
FNB van der Bijl Park
Toyota Midrand
CTM & Italtile
Porche Head Office
– Pretoria
CSIR
BMW
Anglo American

SPECIAL PHARMACEUTICAL SITES



Middelburg Pharmacy
Plascon Test Laboratory
Lea Glen Pharmacy
Phokeng Pathology
Covidien Pharmaceuticals



Eco Aire (Pty) Ltd.

www.ecoaire.com

JHB

t: 011 397 2162 / **e:** sales@ecoaire.com

CAPE TOWN

t: 079 522 0724 / **e:** bradley@ecoaire.com

GARDEN ROUTE

t: 072 533 6747 / **e:** heine@ecoaire.com

KZN

t: 031 701 6114 / **e:** rowland@ecoairekzn.co.za

PORT ELIZABETH

t: 083 625 0462 / **e:** simon@solencosa.co.za